



PUMA 68SV32000XB - 015/020/25

Issue 1.0 July 2001

1M x 32 Static RAM

Description

The PUMA68 range of devices provide a high density surface mount industry standard memory solution which may accommodate various memory technologies including SRAM, EEPROM and Flash. The devices are designed to offer a defined upgrade path and may be user configured as 16 or 32 bits wide.

The PUMA68SV32000XB is a 1Mx32 SRAM module housed in a 68 Jleaded package which complies with the JEDEC 68 PLCC standard. Access times of 15, 20 or 25ns are available. The 3.3V low voltage device is available to commercial and industrial temperature grade.

The part is constructed using eight 512Kx8 SRAM BGA's, with four fitted to the top of the module and four to the bottom.

Features

- Access times of 15, 20 and 25ns.
- 3.3V \pm 10%.
- Commercial, Industrial and military temperature grade.
- JEDEC standard 68 J Lead footprint.
- Industry standard pinout.
- May be organised as 1M x 32, 2M x 16
- Completely Static Operation.

Package Details

PUMA 68 - Plastic 68 'J' Leaded Package
Max. Dimensions (mm) - 25.27 x 25.27 x 5.33

Block Diagram

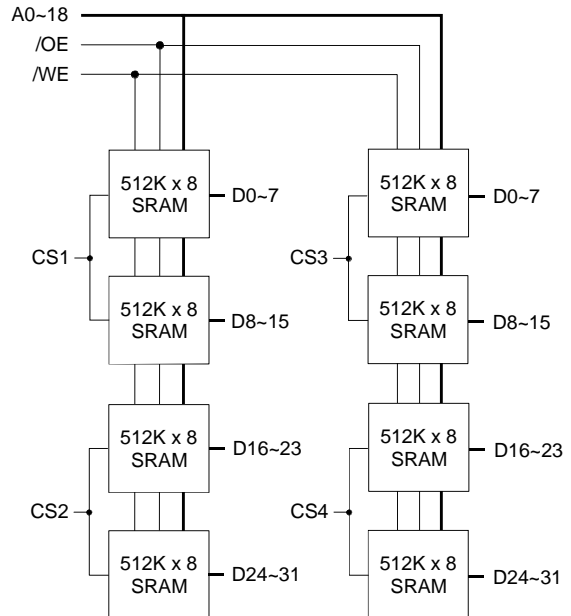

Pin Definition

See page 2.

Pin Functions

Description	Signal
Address Input	A0~A18
Data Input/Output	D0~D31
Chip Select	/CS1~4
Write Enable	/WE
Output Enable	/OE
No Connect	NC
Power	V _{CC}
Ground	V _{SS}

Pin Definition - PUMA68SV32000XB

Pin	Signal	Pin	Signal
1	VCC	35	VCC
2	NC	36	A13
3	/CS1	37	A12
4	/CS2	38	A11
5	/CS3	39	A10
6	/CS4	40	A9
7	A17	41	A8
8	A18	42	A7
9	D16	43	D0
10	D17	44	D1
11	D18	45	D2
12	D19	46	D3
13	GND	47	GND
14	D20	48	D4
15	D21	49	D5
16	D22	50	D6
17	D23	51	D7
18	VCC	52	VCC
19	D24	53	D8
20	D25	54	D9
21	D26	55	D10
22	D27	56	D11
23	GND	57	GND
24	D28	58	D12
25	D29	59	D13
26	D30	60	D14
27	D31	61	D15
28	A6	62	A14
29	A5	63	A15
30	A4	64	A16
31	A3	65	/WE
32	A2	66	/OE
33	A1	67	NC
34	A0	68	NC

Absolute Maximum Ratings⁽¹⁾

Parameter	Symbol	Min		Max	Unit
Voltage on any pin relative to V _{SS}	V _T	-0.3	to	+4.6	V
Power Dissipation	P _T			3.3	W
Storage Temperature	T _{STG}	-55	to	+125	°C

Notes : (1) Stresses above those listed may cause permanent damage to the device. This is a stress rating only and functional operation of the device at these or any other conditions above those indicated in the operational sections of this specification is not implied. Exposure to absolute maximum rating conditions for extended periods may affect reliability

Recommended Operating Conditions

Parameter	Symbol	Min	Typ	Max	Unit	
Supply Voltage	V _{CC}	3.0	3.3	3.6	V	
Input High Voltage	V _{IH}	2.0	-	V _{CC} +0.3	V	
Input Low Voltage	V _{IL} ⁽¹⁾	-0.3	-	0.8	V	
Operating Temperature	T _A	0	-	70	°C	
	T _{AI}	-40	-	85	°C	(I Suffix)

DC Electrical Characteristics

(V_{CC}=3.3V±10%, T_A=-40°C to +85°C)

Parameter		Symbol	Test Condition	Min	Typ	Max	Unit
Input Leakage Current		I _{LI}	V _{IN} = 0V to V _{CC}	-16	-	16	µA
Output Leakage Current		I _{LO}	V _{I/O} = 0V to V _{CC}	-16	-	16	µA
Operating Supply Current ⁽²⁾	32 Bit	I _{CC32}	/CS ⁽¹⁾ =V _{IL} , I _{I/O} =0mA, f=f _{max} , Min. cycle, V _{IN} = V _{IH} or V _{IL}	-	-	920	mA
	16 Bit	I _{CC16}	As Above.	-	-	700	mA
Standby Supply Current		I _{SB}	/CS ⁽¹⁾ =V _{IH} , Min Cycle	-	-	480	mA
		I _{SB1}	F=0MHz, /CS≥V _{CC} -0.2V, V _{IN} ≥V _{CC} -0.2V or V _{IN} ≤0.2V	-	-	120	mA
Output Voltage Low		V _{OL}	I _{OL} =8.0mA	-	-	0.4	V
Output Voltage High		V _{OH}	I _{OH} =-4.0mA	2.4	-	-	V

Notes (1) /CS1~2 or /CS3~4 inputs operate simultaneously for 32 bit mode and singly for 16 bit mode.

(2) At f=f_{MAX} address and data inputs are cycling at max frequency.

Capacitance

($V_{CC} = 3.3V$, $T_A = 25^{\circ}C$, $F=1MHz$.)

Parameter	Symbol	Test Condition	Min	Typ	Max	Unit
Input Capacitance, Address, /OE, /WE	C_{IN1}	$V_{IN} = 0V$	-	-	64	pF
Output Capacitance, 16 bit mode (worst case)	$C_{I/O}$	$V_{I/O} = 0V$	-	-	40	pF

Note : These Parameters are calculated not measured.

Test Conditions

- Input pulse levels : 0V to 3.0V
- Input rise and fall times : 3ns
- Input and Output timing reference levels : 1.5V
- Output Load : See Load Diagram.
- $V_{CC} = 3.3V \pm 10\%$
- PUMA module tested in 32 bit mode.

Output Load

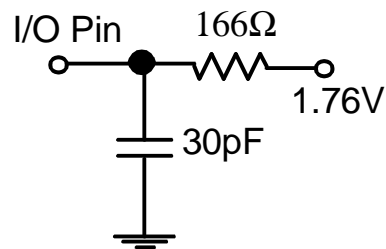

Operation Truth Table

/CS1	/CS2	/CS3	/CS4	/OE	/WE	Supply Current	Mode
L	H	H	H	X	L	I_{CC16}	Write D0~D15
H	L	H	H	X	L	I_{CC16}	Write D16~D31
H	H	L	H	X	L	I_{CC16}	Write D0~D15
H	H	H	L	X	L	I_{CC16}	Write D16~D31
L	L	H	H	X	L	I_{CC32}	Write D0~D31
H	H	L	L	X	L	I_{CC32}	Write D0~D31
L	H	H	H	L	H	I_{CC16}	Read D0~D15
H	L	H	H	L	H	I_{CC16}	Read D16~D31
H	H	L	H	L	H	I_{CC16}	Read D0~D15
H	H	H	L	L	H	I_{CC16}	Read D16~D31
L	L	H	H	L	H	I_{CC32}	Read D0~D31
H	H	L	L	L	H	I_{CC32}	Read D0~D31
X	X	X	X	H	H	I_{CC32}/I_{CC16}	D0~D31 High-Z
H	H	H	H	X	X	I_{SB}, I_{SB1}	D0~D31 Standby

Notes : $H=V_{IH}$; $L=V_{IL}$; $X=V_{IH}$ or V_{IL}

Read Cycle

		15		20		25		
Parameter	Symbol	Min	Max	Min	Max	Min	Max	Units
Read Cycle Time	t_{RC}	15	-	20	-	25	-	ns
Address Access Time	t_{AA}	-	15	-	20	-	25	ns
Chip Select Access Time	t_{ACS}	-	15	-	20	-	25	ns
Output Enable to Output Valid	t_{OE}	-	7	-	9	-	11	ns
Output Hold From Address Change	t_{OH}	3	-	3	-	3	-	ns
Chip Selection to Output in Low Z	t_{CLZ}	3	-	3	-	3	-	ns
Output Enable to Output in Low Z	t_{OLZ}	0	-	0	-	0	-	ns
Chip Deselection to Output in High Z	t_{CHZ}	0	7	0	9	0	11	ns
Output Disable to Output in High Z	t_{OHZ}	0	7	0	9	0	11	ns

Write Cycle

		15		20		25		
Parameter	Symbol	Min	Max	Min	Max	Min	Max	Units
Write Cycle Time	t_{WC}	15	-	20	-	25	-	ns
Chip Selection to End of Write	t_{CW}	12	-	14	-	16	-	ns
Address Valid to End of Write	t_{AW}	12	-	14	-	16	-	ns
Address Setup Time	t_{AS}	0	-	0	-	0	-	ns
Write Pulse Width (/OE High)	t_{WP}	12	-	14	-	16	-	ns
Write Recovery Time	t_{WR}	0	-	0	-	0	-	ns
Write to Output in High Z	t_{WHZ}	0	7	0	9	0	11	ns
Data to Write Time Overlap	t_{DW}	8	-	10	-	12	-	ns
Data Hold time from Write Time	t_{DH}	0	-	0	-	0	-	ns
Output Active from End of Write	t_{OW}	3	-	3	-	3	-	ns

Read Cycle 1

(Address Controlled, $/CS=/OE=V_{IL}$, $/WE=V_{IH}$)

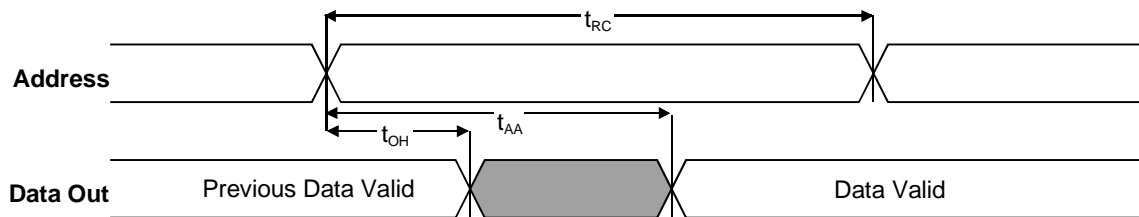

Read Cycle 2

($/WE = V_{IH}$)

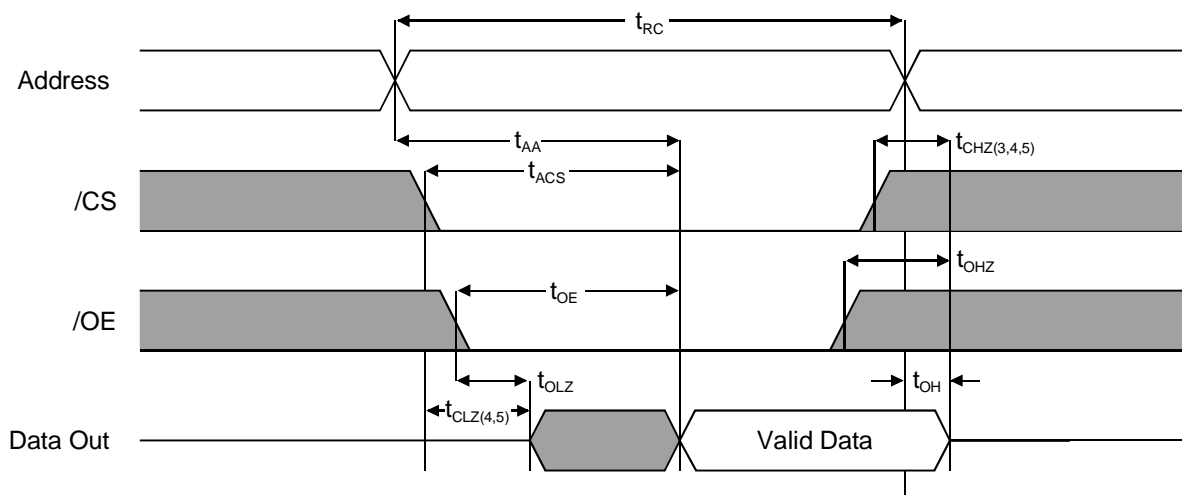

NOTES(READ CYCLE)

1. $/WE$ is high for read cycle.
2. All read cycle timing is referenced from the last valid address to the first transition address.
3. t_{CHZ} and t_{OHZ} are defined as the time at which the outputs achieve the open circuit condition and are not referenced to V_{OH} or V_{OL} levels.
4. At any given temperature and voltage condition, $t_{CHZ}(\text{Max.})$ is less than $t_{CLZ}(\text{Min.})$ both for a given device and from device to device.
5. Transition is measured $\pm 200\text{mV}$ from steady state voltage with Load(B). This parameter is sampled and not 100% tested.
6. Device is continuously selected with $/CS=V_{IL}$.
7. Address valid prior to coincident with $/CS$ transition low.
8. For common I/O applications, minimization or elimination of bus contention conditions is necessary during read and write cycle.
9. $/CS=/CS1-4$

Write Cycle 1

(/OE = Clock)

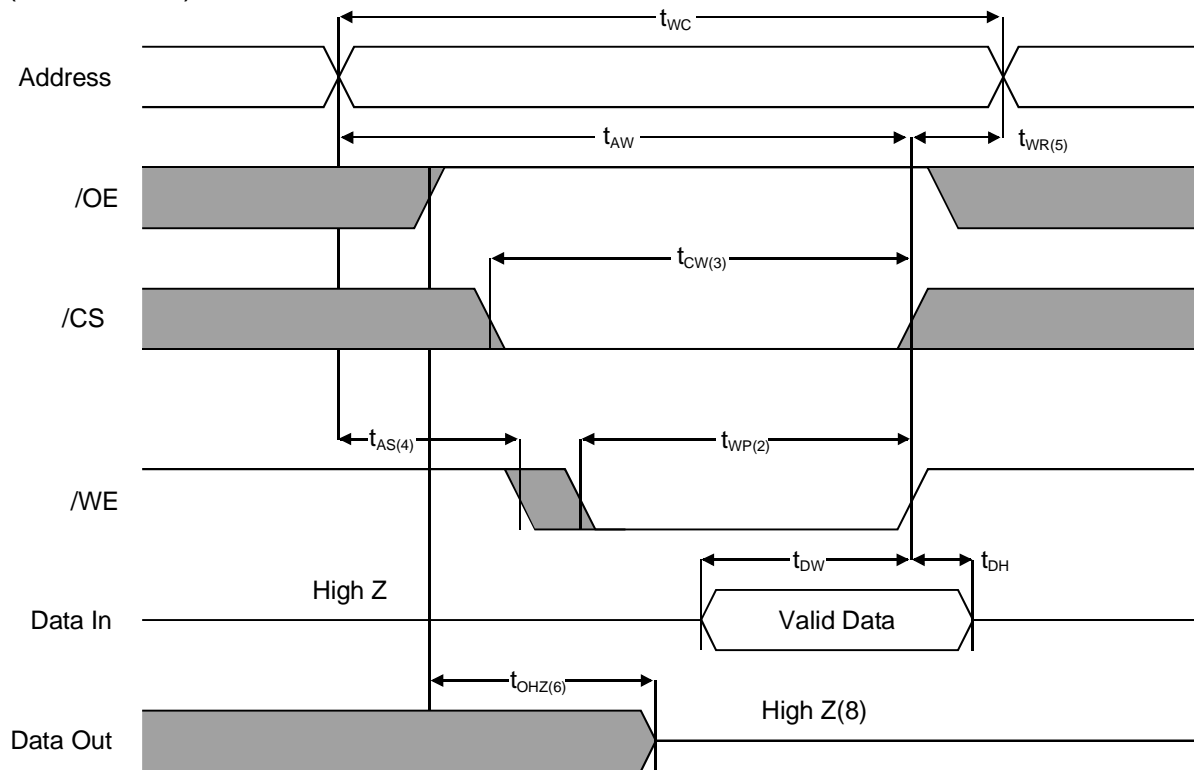

NOTES(WRITE CYCLE)

1. All write cycle timing is referenced from the last valid address to the first transition address.
2. A write occurs during the overlap of a low /CS and /WE. A write begins at the latest transition /CS going low and /WE going low ; A write ends at the earliest transition /CS going high or /WE going high. t_{WP} is measured from the beginning of write to the end of write.
3. t_{CW} is measured from the later of /CS going low to end of write.
4. t_{AS} is measured from the address valid to the beginning of write.
5. t_{WR} is measured from the end of write to the address change. t_{WR} applied in case a write ends as /CS or /WE going high.
6. If OE, /CS and /WE are in the Read Mode during this period, the I/O pins are in the output low-Z state. Inputs of opposite phase of the output must not be applied because bus contention can occur.
7. For common I/O applications, minimization or elimination of bus contention conditions is necessary during read and write cycle.
8. If /CS goes low simultaneously with /WE going or after /WE going low, the outputs remain high impedance state.
9. Dout is the read data of the new address.
10. When /CS is low : I/O pins are in the output state. The input signals in the opposite phase leading to the output should not be applied.
11. /CS=/CS1~4

Write Cycle 2

(/OE = Low Fixed)

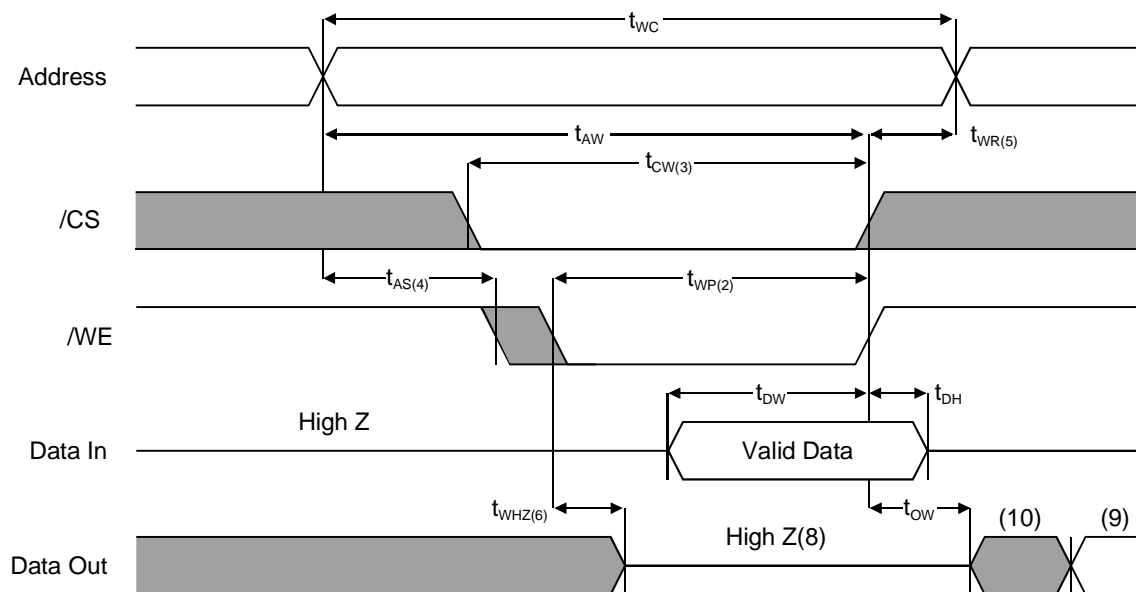

NOTES(WRITE CYCLE)

- All write cycle timing is referenced from the last valid address to the first transition address.
- A write occurs during the overlap of a low /CS and /WE. A write begins at the latest transition /CS going low and /WE going low ; A write ends at the earliest transition /CS going high or /WE going high. t_{WP} is measured from the beginning of write to the end of write.
- t_{CW} is measured from the later of /CS going low to end of write.
- t_{AS} is measured from the address valid to the beginning of write.
- t_{WR} is measured from the end of write to the address change. t_{WR} applied in case a write ends as /CS or /WE going high.
- If OE, /CS and /WE are in the Read Mode during this period, the I/O pins are in the output low-Z state. Inputs of opposite phase of the output must not be applied because bus contention can occur.
- For common I/O applications, minimization or elimination of bus contention conditions is necessary during read and write cycle.
- If /CS goes low simultaneously with /WE going or after /WE going low, the outputs remain high impedance state.
- Dout is the read data of the new address.
- When /CS is low : I/O pins are in the output state. The input signals in the opposite phase leading to the output should not be applied.
- /CS=/CS1~4

Write Cycle 3

(/CS = Controlled)

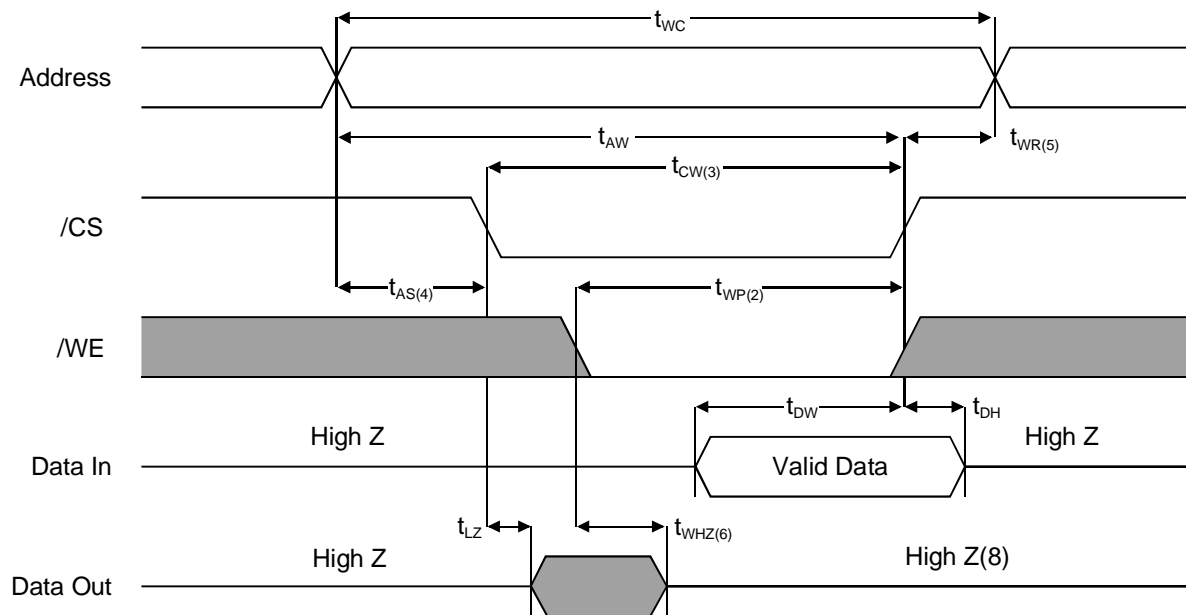

NOTES(WRITE CYCLE)

- All write cycle timing is referenced from the last valid address to the first transition address.
- A write occurs during the overlap of a low /CS and /WE. A write begins at the latest transition /CS going low and /WE going low ; A write ends at the earliest transition /CS going high or /WE going high. t_{WP} is measured from the beginning of write to the end of write.
- t_{CW} is measured from the later of /CS going low to end of write.
- t_{AS} is measured from the address valid to the beginning of write.
- t_{WR} is measured from the end of write to the address change. t_{WR} applied in case a write ends as /CS or /WE going high.
- If /OE, /CS and /WE are in the Read Mode during this period, the I/O pins are in the output low-Z state. Inputs of opposite phase of the output must not be applied because bus contention can occur.
- For common I/O applications, minimization or elimination of bus contention conditions is necessary during read and write cycle.
- If /CS goes low simultaneously with /WE going or after /WE going low, the outputs remain high impedance state.
- Dout is the read data of the new address.
- When /CS is low : I/O pins are in the output state. The input signals in the opposite phase leading to the output should not be applied.
- /CS=/CS1~4

PUMA 68 Pin JEDEC Surface Mount PLCC

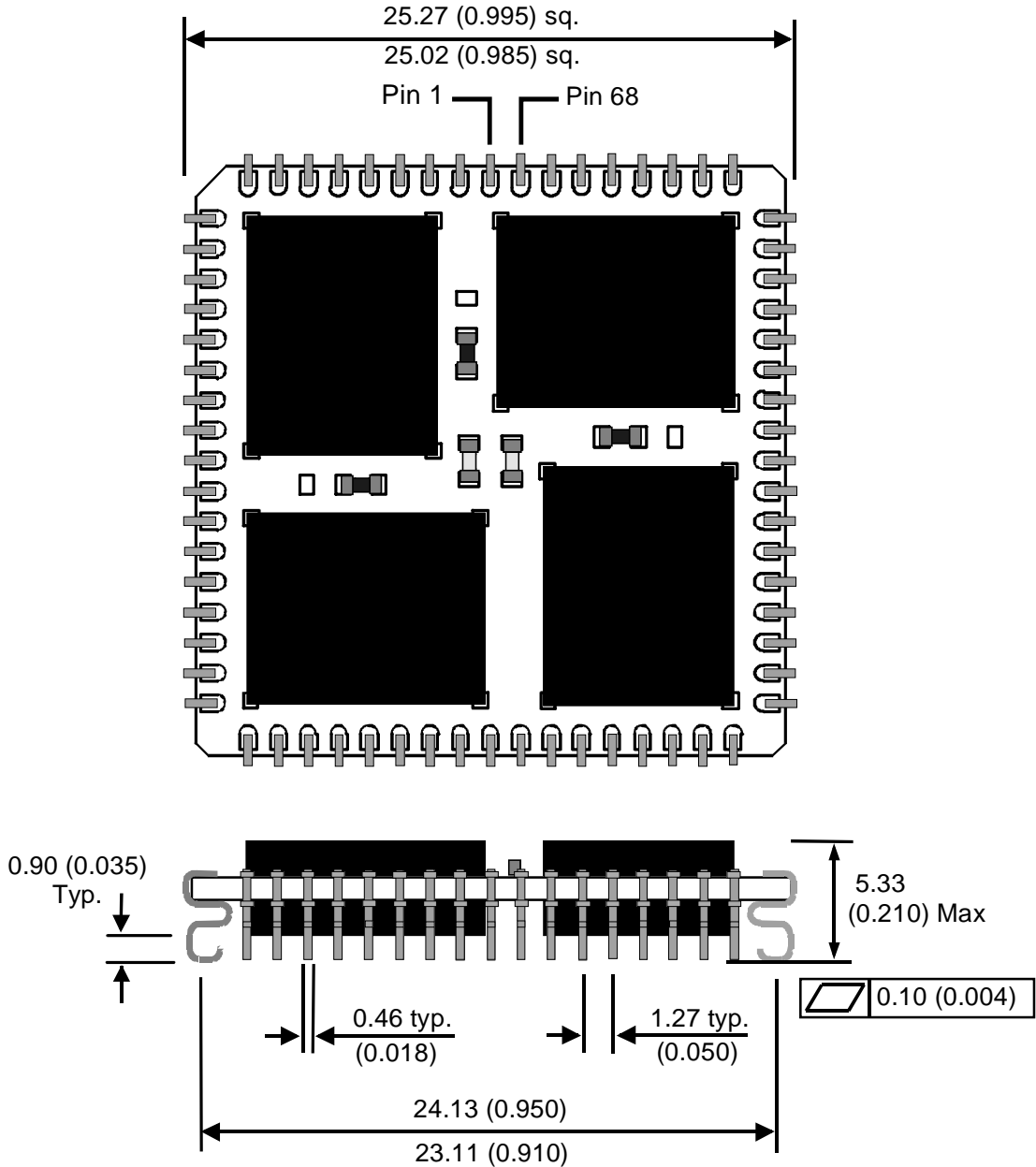

Ordering Information

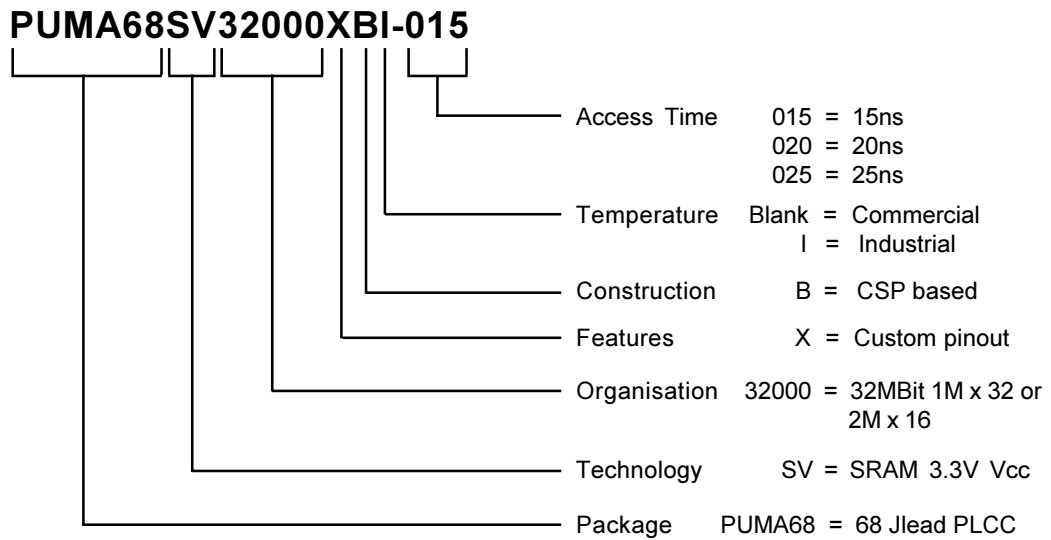

Note :

Although this data is believed to be accurate the information contained herein is not intended to and does not create any warranty of merchantability or fitness for a particular purpose.

Our products are subject to a constant process of development. Data may be changed without notice.

Products are not authorised for use as critical components in life support devices without the express written approval of a company director.

Visual Inspection Standard

All devices inspected to ANSI/J-STD-001B Class 2 standard

Moisture Sensitivity

Devices are **moisture sensitive**.

Shelf Life in Sealed Bag 12 months at <40°C and <90% relative humidity (RH).

After this bag has been opened, devices that will be subjected to infrared reflow, vapour phase reflow, or equivalent processing (peak package body temp 220°C) **must be** :

A : Mounted within 72 Hours at factory conditions of <30°C/60% RH

OR

B : Stored at <20% RH

If these conditions are not met or indicator card is >20% when read at 23°C +/-5% devices **require baking** as specified below.

If baking is required, devices may be baked for :-

A : 24 hours at 125°C +/-5% for high temperature device containers

OR

B : 192 hours at 40°C +5°C/-0°C and <5% RH for low temperature device containers.

Packaging Standard

Devices packaged in dry nitrogen, JED-STD-020.

Packaged in trays as standard.

Tape and reel available for shipment quantities exceeding 200pcs upon request.

Soldering Recommendations

IR/Convection -	Ramp Rate	6°C/sec max.
	Temp. exceeding 183°C	150 secs. max.
	Peak Temperature	225°C
	Time within 5°C of peak	20 secs max.
	Ramp down	6°C/sec max.
Vapour Phase -	Ramp up rate	6°C/sec max.
	Peak Temperature	215 - 219°C
	Time within 5°C of peak	60 secs max.
	Ramp down	6°C/sec max.

The above conditions must not be exceeded

Note : The above recommendations are based on standard industry practice. Failure to comply with the above recommendations invalidates product warranty.