

# TRAILING EDGE PRODUCT - MINIMUM ORDER APPLIES



## 2M x 8 SRAM MODULE

### SYS82000RKXC - 70/85/10/12

Elm Road, West Chirton Industrial Estate, North Shields,  
NE29 8SE, ENGLAND. TEL +44 (0191) 2930500. FAX +44 (0191)  
2590997

Issue 1.2 : January 1999

#### Description

The SYS82000RKXC is a plastic 16Mbit Static RAM Module housed in a standard 38 pin Single In-Line package organised as 2M x 8 with access times of 70, 85, 100, or 120 ns.

The module is constructed using four 512Kx8 SRAMs in TSOPII packages mounted onto an FR4 epoxy substrate. This offers an extremely high PCB packing density.

The device is offered in standard and low power versions, with the -L module having a low voltage data retention mode for battery backed applications.

#### Features

- Access Times of 70/85/100/120 ns.
- Low Power Disipation:
 

Operating	600 mW (Max.)
Standby-L Version	1.1 mW (Max.)
- 5 Volt Supply  $\pm 10\%$ .
- Completely Static Operation.
- Low Voltage  $V_{CC}$  Data Retention.
- On-board Decoding & Decoupling Capacitors.
- 38 Pin Single-In-Line package (SIP).
- Upgrade path to SYS84000RKXC (32Mbits).

#### Block Diagram

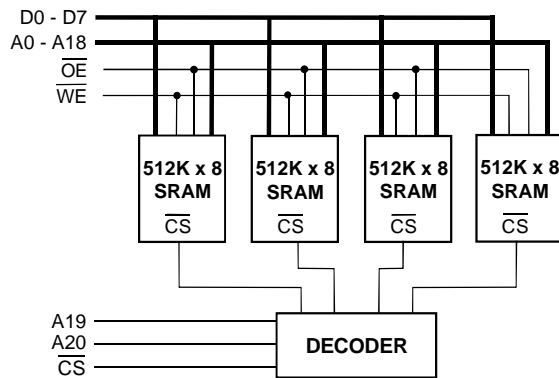

#### Pin Definition

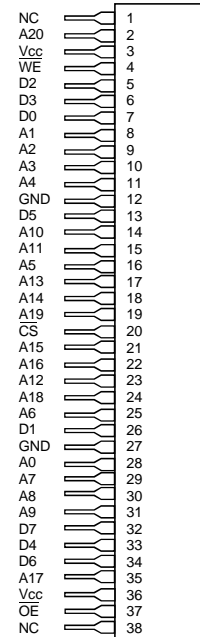

Pin 38 is A21 on the  
SYS84000RKXC upgrade module.

#### Pin Functions

Address Inputs	<b>A0 ~ A20</b>
Data Input/Output	<b>D0 ~ D7</b>
Chip Select	<b><math>\overline{CS}</math></b>
Write Enable	<b><math>\overline{WE}</math></b>
Output Enable	<b><math>\overline{OE}</math></b>
No Connect	<b>NC</b>
Power (+5V)	<b><math>V_{CC}</math></b>
Ground	<b>GND</b>

#### Package Details

Plastic 38 pin Single-In-Line (SIP)

**DC OPERATING CONDITIONS****Absolute Maximum Ratings** <sup>(1)</sup>

Parameter	Symbol	min	typ	max	unit
Voltage on any pin relative to $V_{SS}$	$V_T$	-0.3	-	+7	V
Power Dissipation	$P_T$	-	-	4.0	W
Storage Temperature	$T_{STG}$	-55	-	+125	°C

Notes :

(1) Stresses above those listed may cause permanent damage to the device. This is a stress rating only and functional operation of the device at those or any other conditions above those indicated in the operational sections of this specification is not implied. Exposure to absolute maximum rating conditions for extended periods may affect device reliability.

(2)  $V_T$  can be -3.0 V pulse of less than 30 ns.

**Recommended Operating Conditions**

Parameter	Symbol	min	typ	max	unit
Supply Voltage	$V_{CC}$	4.5	5.0	5.5	V
Input High Voltage	$V_{IH}$	2.2	-	$V_{CC}+0.3$	V
Input Low Voltage	$V_{IL}$	-0.3	-	0.8	V
Operating Temperature	$T_A$	0	-	70	°C
	$T_{AI}$	-40	-	85	°C (I)

**DC Electrical Characteristics** ( $V_{CC}=5V\pm 10\%$ ) $T_A$  0 to 70°C

Parameter	Symbol	Test Condition	min	typ	max	Unit
I/P Leakage Current	$I_{LI}$	$V_{IN} = GND$ to $V_{CC}$	-4	-	4	$\mu A$
Output Leakage Current	$I_{LO}$	$\overline{CS} = V_{IH}$ , $V_{IO} = GND$ to $V_{CC}$	-4	-	4	$\mu A$
Operating Supply Current	$I_{CC}$	$\overline{CS} = V_{IL}$ , min cycle, Duty = 100%	-	-	109	mA
Standby Supply Current TTL levels	$I_{SB1}$	$\overline{CS} = V_{IH}$	-	-	12	mA
	-L Version $I_{SB2}$	$\overline{CS} = V_{CC}-0.2V$ , $0.2 > V_{IN} > V_{CC}-0.2V$	-	-	200	$\mu A$
Output Low Voltage	$V_{OL}$	$I_{OL} = 2.1mA$	-	-	0.4	V
Output High Voltage	$V_{OH}$	$I_{OH} = -1.0mA$	2.4	-	-	V

**Capacitance** ( $V_{CC}=5V\pm 10\%$ ,  $T_A=25^\circ C$ )

Note: Capacitance calculated, not measured.

Parameter	Symbol	Test Condition	typ	max	Unit
Input Capacitance ( $\overline{CS}$ , A19, A20)	$C_{IN1}$	$V_{IN} = 0V$	-	8	pF
Input Capacitance (A0-18, OE, WE)	$C_{IN2}$	$V_{IN} = 0V$	-	32	pF
I/O Capacitance	$C_{IO}$	$V_{IO} = 0V$	-	10	pF

### Operation Truth Table

$\overline{CS}$	$\overline{OE}$	$\overline{WE}$	DATA PINS	SUPPLY CURRENT	MODE
H	X	X	High Impedance	$I_{SB1}, I_{SB2}$	Standby
L	L	H	Data Out	$I_{CC}$	Read
L	X	L	Data In	$I_{CC}$	Write
L	H	H	High Impedance	$I_{CC}$	Output Disabled

Notes : H =  $V_{IH}$  : L =  $V_{IL}$  : X =  $V_{IH}$  or  $V_{IL}$

### AC Test Conditions

- \* Input pulse levels: 0 V to 3.0V
- \* Input rise and fall times: 5ns
- \* Input and Output timing reference levels: 1.5V
- \* Output load: see diagram
- \*  $V_{CC} = 5V \pm 10\%$

### Output Load

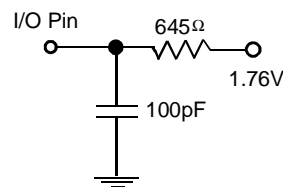

### Low $V_{CC}$ Data Retention Characteristics - L Version Only ( $T_{OP} = 0^{\circ}C$ to $70^{\circ}C$ )

Parameter	Symbol	Test Condition	-L Part			Unit
			min	typ	max	
$V_{CC}$ for Data Retention	$V_{DR}$	$\overline{CS} \geq V_{CC} - 0.2V$ $0.2V \geq V_{in} \geq V_{CC} - 0.2$	2.0	-	-	V
Data Retention Current	$I_{CCDR}$	$V_{CC} = 3.0V, \overline{CS} = V_{CC} - 0.2V, 0.2V \geq V_{in} \geq V_{CC} - 0.2$	-	-	400	$\mu A$
Chip Deselect to Data Ret. Time	$t_{CDR}$	See Retention Waveform	0	-	-	ns
Operation Recovery Time	$t_R$	See Retention Waveform	5	-	-	ms

**AC OPERATING CONDITIONS****Read Cycle**

Parameter	Symbol	-70		-85		-10		-12		Unit
		min	max	min	max	min	max	min	max	
Read Cycle Time	$t_{RC}$	70	-	85	-	100	-	120	-	ns
Address Access Time	$t_{AA}$	-	70	-	85	-	100	-	120	ns
Chip Select Access Time	$t_{ACS}$	-	70	-	85	-	100	-	120	ns
Output Enable to Output Valid	$t_{OE}$	-	40	-	45	-	50	-	55	ns
Output Hold from Address Change	$t_{OH}$	10	-	10	-	10	-	10	-	ns
Chip Selection to Output in Low Z	$t_{CLZ}$	10	-	10	-	10	-	10	-	ns
Output Enable to Output in Low Z	$t_{OLZ}$	5	-	5	-	5	-	5	-	ns
Chip Deselection to O/P in High Z	$t_{CHZ}$	0	30	0	30	0	35	0	40	ns
Output Disable to Output in High Z	$t_{OHZ}$	0	30	0	30	0	35	0	40	ns

**Write Cycle**

Parameter	Symbol	-70		-85		-10		-12		Unit
		min	max	min	max	min	max	min	max	
Write Cycle Time	$t_{WC}$	70	-	85	-	100	-	120	-	ns
Chip Selection to End of Write	$t_{CW}$	60	-	75	-	80	-	100	-	ns
Address Setup Time	$t_{AS}$	0	-	0	-	0	-	0	-	ns
Address Valid to End of Write	$t_{AW}$	60	-	75	-	80	-	100	-	ns
Write Pulse Width	$t_{WP}$	55	-	65	-	70	-	80	-	ns
Write Recovery Time	$t_{WR}$	5	-	5	-	5	-	5	-	ns
Write to Output in High Z	$t_{WHZ}$	0	25	0	30	0	35	0	40	ns
Data to Write Time Overlap	$t_{DW}$	30	-	35	-	40	-	45	-	ns
Data Hold from Write Time	$t_{DH}$	0	-	0	-	0	-	0	-	ns
Output active from end of write	$t_{OW}$	5	-	5	-	5	-	5	-	ns





**Package Information**      Dimensions in mm

**Plastic 38 Pin Single-In-Line (SIP)**

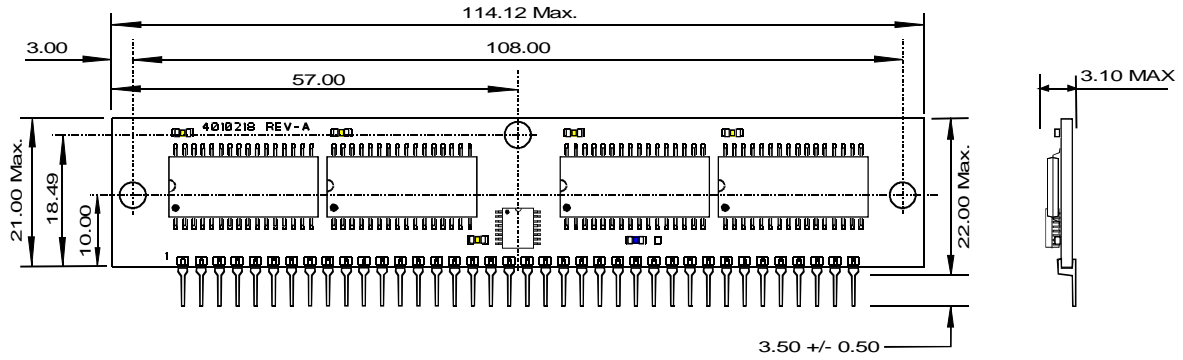

**Ordering Information**

**SYS82000RKXCLI - 70**

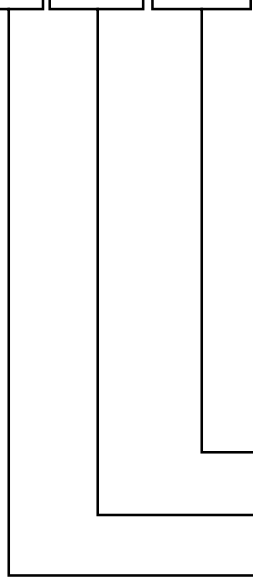

- Speed
  - 70 = 70 ns
  - 85 = 85 ns
  - 10 = 100 ns
  - 12 = 120 ns
- Temperature Range
  - Blank = Commercial Temperature
  - I = Industrial Temperature
- Power Consumption
  - Blank = Standard Part
  - L = Low Power Part
- Package
  - RKXC = Plastic 38 pin SIP
- Organization
  - 82000 = 2M x 8
- Memory Type
  - SYS = Static RAM

**Note :**

Although this data is believed to be accurate, the information contained herein, is not intended to and does not create any warranty of merchantability or fitness for a particular purpose. Our products are subject to a constant process of development. Data may be changed at any time without notice. Products are not authorised for use as critical components in life support devices without the express written approval of a company director.