



## 512K x 32 SRAM MODULE

### PUMA 68S16000/AB-020/025/35/45

Issue 5.0 : May 2001

#### Description

The PUMA 68S16000 is a 16Mbit CMOS High Speed Static RAM in a JEDEC 68 pin surface mount PLCC, available with access times of 20, 25, 35, and 45ns. The output width is user configurable as 8, 16 or 32 bits using four Chip Selects ( $\overline{CS1-4}$ ). The device is available with the option of independent or single  $\overline{WE}$  control. The plastic device is screened to ensure high reliability.

The device features low power standby, multiple ground pins for maximum noise immunity and TTL compatible inputs and outputs. The PUMA 68S16000 offers a dramatic space saving advantage over four standard 512Kx8 devices.

#### Features

- Very Fast Access Times of 20,25,35,45 ns.
- JEDEC 68 'J' leaded plastic Surface Mount Substrate.
- Commercial, Industrial, or Military Grade.
- User Configurable as 8 / 16 / 32 bit wide output.
- Operating Power : 3.86 W (max)
- Standby Power : (CMOS) 220mW (max)
- Fully Static operation.
- Single 5V±10% Power supply.

#### Block Diagram (see sheet 7 for 'A' version)

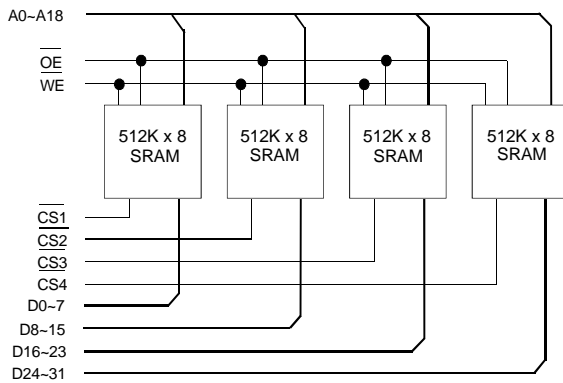

#### Pin Definition (see sheet 7 for 'A' version)

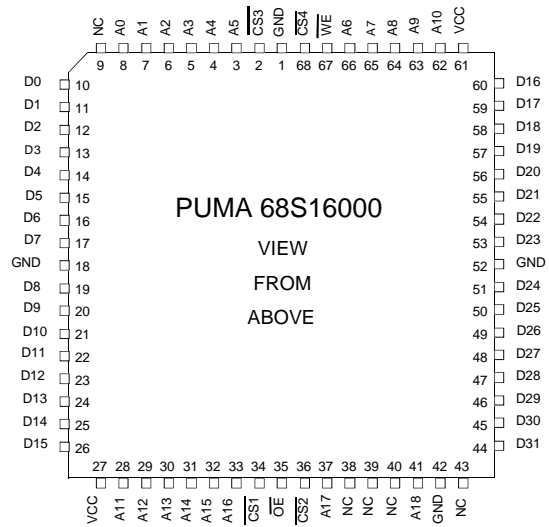

#### Pin Functions

Address Inputs	<b>A0 - A18</b>
Data Input/Output	<b>D0 - D31</b>
Chip Select	<b><math>\overline{CS1-4}</math></b>
Write Enable	<b><math>\overline{WE}</math></b>
Output Enable	<b><math>\overline{OE}</math></b>
No Connect	<b>NC</b>
Power (+5V)	<b>V<sub>cc</sub></b>
Ground	<b>GND</b>

#### Package Details

Plastic 68 J-Leaded JEDEC PLCC

**DC OPERATING CONDITIONS****Absolute Maximum Ratings** <sup>(1)</sup>

Parameter	Symbol	Min	Typ	Max	Unit
Voltage on any pin relative to $V_{SS}$	$V_T^{(2)}$	-0.5	-	7.0	V
Power Dissipation	$P_T$	-	-	5.0	W
Storage Temperature	$T_{STG}$	-65	-	150	°C

Notes : (1) Stresses above those listed may cause permanent damage to the device. This is a stress rating only and functional operation of the device at those or any other conditions above those indicated in the operational sections of this specification is not implied. Exposure to absolute maximum rating conditions for extended periods may affect device reliability.

**Recommended Operating Conditions**

Parameter	Symbol	Min	Typ	Max	Unit	
Supply Voltage	$V_{CC}$	4.5	5.0	5.5	V	
Input High Voltage	$V_{IH}$	2.2	-	$V_{CC}+0.5$	V	
Input Low Voltage	$V_{IL}$	-0.3	-	0.8	V	
Operating Temperature	(Commercial)	$T_A$	0	-	70	°C
	(Industrial)	$T_{AI}$	-40	-	85	°C (Suffix I)
	(Military)	$T_{AM}$	-55	-	125	°C (Suffix M)

**DC Electrical Characteristics** ( $V_{CC}=5V\pm 10\%$ ,  $T_A = -55^\circ\text{C}$  to  $+125^\circ\text{C}$ )

Parameter	Symbol	Test Condition	Min	Typ	max	Unit	
I/P Leakage Current	Address, $\overline{OE}$ , $\overline{WE}$	$I_{LI}$	$0V \leq V_{IN} \leq V_{CC}$	-20	-	20	$\mu\text{A}$
Output Leakage Current		$I_{LO}$	$\overline{CS} = V_{IH}$ , $V_{IO} = \text{GND to } V_{CC}$	-20	-	20	$\mu\text{A}$
Operating Supply Current	32-bit mode	$I_{CC32}$	Min. Cycle, $\overline{CS} = V_{IL}$ , $f=f_{MAX}$ , $I_{OUT} = 0\text{mA}$	-	-	720	mA
	16-bit mode	$I_{CC16}$	As Above.	-	-	480	mA
	8-bit mode	$I_{CC8}$	As Above.	-	-	360	mA
Standby Supply Current	TTL levels	$I_{SB1}$	$\overline{CS} = V_{IH}$ , $f=f_{MAX}$	-	-	240	mA
	CMOS levels	$I_{SB2}$	$\overline{CS} \geq V_{CC} - 0.2V$ , $0.2 \leq V_{IN} \leq V_{CC} - 0.2V$ , $f=0$	-	-	40	mA
Output Voltage		$V_{OL}$	$I_{OL} = 8.0\text{mA}$	-	-	0.4	V
		$V_{OH}$	$I_{OH} = -4.0\text{mA}$	2.4	-	-	V

Notes :

1/ Typical values are at  $V_{CC}=5.0V$ ,  $T_A=25^\circ\text{C}$  and specified loading.

2/  $\overline{CS}$  above refers to  $\overline{CS1-4}$ .

3/ At  $f=f_{MAX}$  address and data inputs are cycling at maximum frequency.

**Capacitance** ( $V_{CC}=5V\pm 10\%$ ,  $T_A=25^\circ C$ ) Note: Capacitance calculated, not measured.

Parameter	Symbol	Test Condition	max	Unit
Input Capacitance (Address, $\overline{OE}$ , $\overline{WE}$ )	$C_{IN1}$	$V_{IN} = 0V$	30	pF
I/P Capacitance (other)	$C_{IN2}$	$V_{IN} = 0V$	7	pF
I/O Capacitance	$C_{I/O}$	$V_{I/O} = 0V$	38	pF

**AC Test Conditions** **Output Load**

- \* Input pulse levels: 0V to 3.0V
- \* Input rise and fall times: 5ns
- \* Input and Output timing reference levels: 1.5V
- \* Output load: see diagram
- \*  $V_{CC}=5V\pm 10\%$

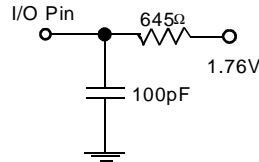

**Operation Truth Table**

$\overline{CS}$	$\overline{OE}$	$\overline{WE}$	DATA PINS	SUPPLY CURRENT	MODE
H	X	X	High Impedance	$I_{SB1}, I_{SB2}, I_{SB3}$	Standby
L	L	H	Data Out	$I_{CC32}, I_{CC16}, I_{CC8}$	Read
L	H	L	Data In	$I_{CC32}, I_{CC16}, I_{CC8}$	Write
L	L	L	Data In	$I_{CC32}, I_{CC16}, I_{CC8}$	Write
L	H	H	High-Impedance	$I_{SB1}, I_{SB2}, I_{SB3}$	High-Z

Notes : H =  $V_{IH}$  : L =  $V_{IL}$  : X =  $V_{IH}$  or  $V_{IL}$

$\overline{CS}$  above refers to  $\overline{CS1-4}$ .

**AC OPERATING CONDITIONS****Read Cycle**

<i>Parameter</i>	<i>Symbol</i>	<i>-020</i>		<i>-025</i>		<i>-35</i>		<i>-45</i>		<i>Unit</i>
		<i>min</i>	<i>max</i>	<i>min</i>	<i>max</i>	<i>min</i>	<i>max</i>	<i>min</i>	<i>max</i>	
Read Cycle Time	$t_{RC}$	20	-	25	-	35	-	45	-	ns
Address Access Time	$t_{AA}$	-	20	-	25	-	35	-	45	ns
Chip Select Access Time	$t_{ACS}$	-	20	-	25	-	35	-	45	ns
Output Enable to Output Valid	$t_{OE}$	-	10	-	12	-	14	-	16	ns
Output Hold from Address Change	$t_{OH}$	4	-	5	-	6	-	7	-	ns
Chip Selection to Output in Low Z	$t_{CLZ}$	3	-	3	-	3	-	3	-	ns
Output Enable to Output in Low Z	$t_{OLZ}$	0	-	0	-	0	-	0	-	ns
Chip Deselection to O/P in High Z	$t_{CHZ}$	0	8	0	10	0	12	0	15	ns
Output Disable to Output in High Z	$t_{OHZ}$	0	8	0	10	0	12	0	15	ns

**Write Cycle**

<i>Parameter</i>	<i>Symbol</i>	<i>-020</i>		<i>-025</i>		<i>-35</i>		<i>-45</i>		<i>Unit</i>
		<i>min</i>	<i>max</i>	<i>min</i>	<i>max</i>	<i>min</i>	<i>max</i>	<i>min</i>	<i>max</i>	
Write Cycle Time	$t_{WC}$	20	-	25	-	35	-	45	-	ns
Chip Selection to End of Write	$t_{CW}$	15	-	20	-	25	-	35	-	ns
Address Valid to End of Write	$t_{AW}$	15	-	20	-	25	-	35	-	ns
Address Setup Time	$t_{AS}$	0	-	0	-	0	-	0	-	ns
Write Pulse Width	$t_{WP}$	15	-	20	-	25	-	35	-	ns
Write Recovery Time	$t_{WR}$	0	-	0	-	0	-	0	-	ns
Write to Output in High Z	$t_{WHZ}$	0	8	0	10	0	12	0	14	ns
Data to Write Time Overlap	$t_{DW}$	9	-	10	-	12	-	14	-	ns
Data Hold from Write Time	$t_{DH}$	0	-	0	-	0	-	0	-	ns
Output active from end of write	$t_{OW}$	4	-	5	-	7	-	9	-	ns

**Read Cycle Timing Waveform** <sup>(1,2)</sup>

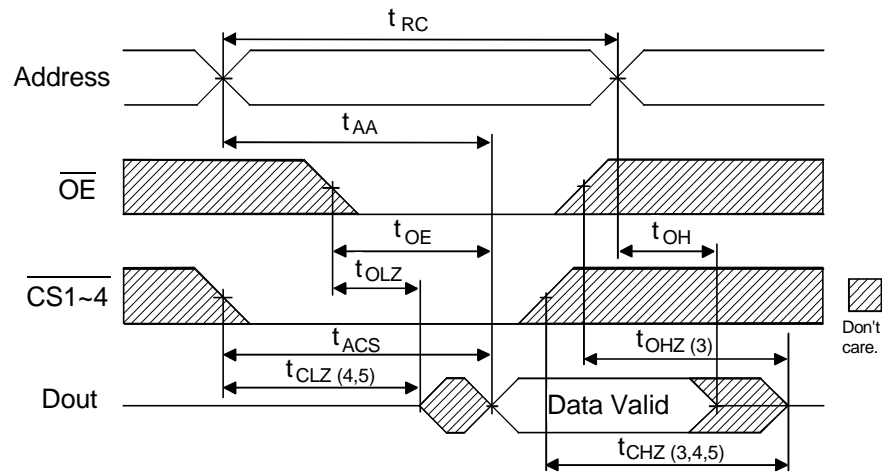

**AC Read Characteristics Notes**

- (1)  $\overline{WE}$  is High for Read Cycle.
- (2) All read cycle timing is referenced from the last valid address to the first transition address.
- (3)  $t_{CHZ}$  and  $t_{OHZ}$  are defined as the time at which the outputs achieve open circuit conditions and are not referenced to output voltage levels.
- (4) At any given temperature and voltage condition,  $t_{CHZ}$  (max) is less than  $t_{CLZ}$  (min) both for a given module and from module to module.
- (5) These parameters are sampled and not 100% tested.

**Write Cycle No.1 Timing Waveform** <sup>(1,4)</sup>

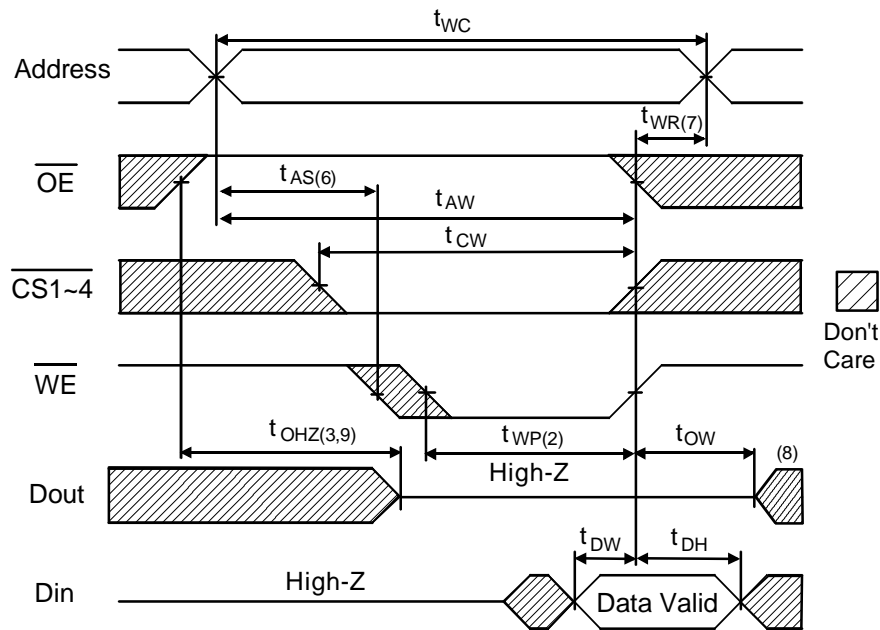

### Write Cycle No.2 Timing Waveform <sup>(1,5)</sup>

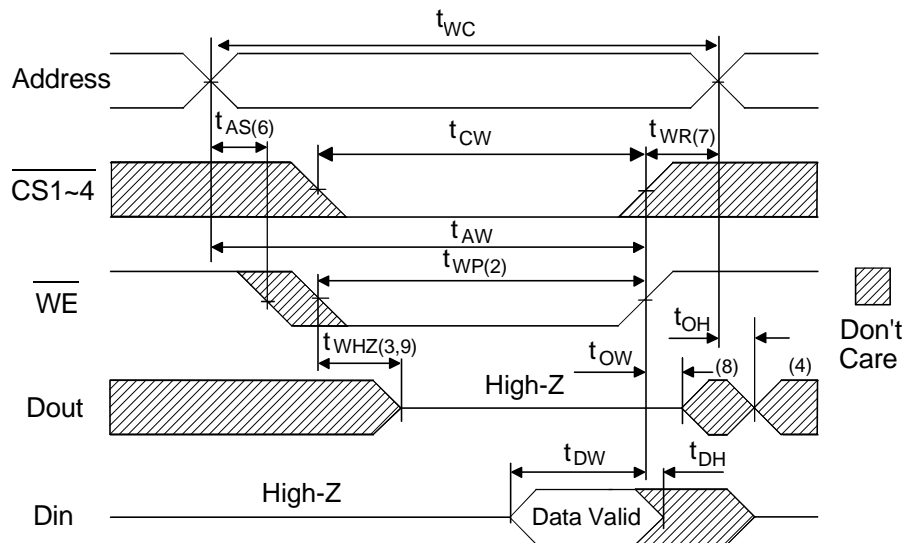

### AC Write Characteristics Notes

- (1) All write cycle timing is referenced from the last valid address to the first transition address.
- (2) All writes occur during the overlap of  $\overline{CS1\sim4}$  and  $\overline{WE}$  low.
- (3) If  $\overline{OE}$ ,  $\overline{CS1\sim4}$ , and  $\overline{WE}$  are in the Read mode during this period, the I/O pins are low impedance state. Inputs of opposite phase to the output must not be applied because bus contention can occur.
- (4) Dout is the Read data of the new address.
- (5)  $\overline{OE}$  is continuously low.
- (6) Address is valid prior to or coincident with  $\overline{CS1\sim4}$  and  $\overline{WE}$  low, too avoid inadvertant writes.
- (7)  $\overline{CS1\sim4}$  or  $\overline{WE}$  must be high during address transitions.
- (8) When  $\overline{CS1\sim4}$  are low : I/O pins are in the output state. Input signals of opposite phase leading to the output should not be applied.
- (9) Defined as the time at which the outputs achieve open circuit conditions and are not referenced to output voltage levels. These parameters are sampled and not 100% tested.

**Version 'A' Pin Definition** **Version 'A' Block Diagram**

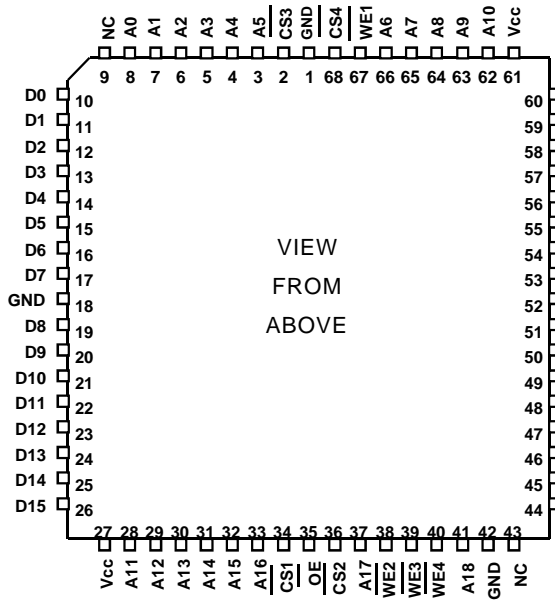

VIEW  
FROM  
ABOVE

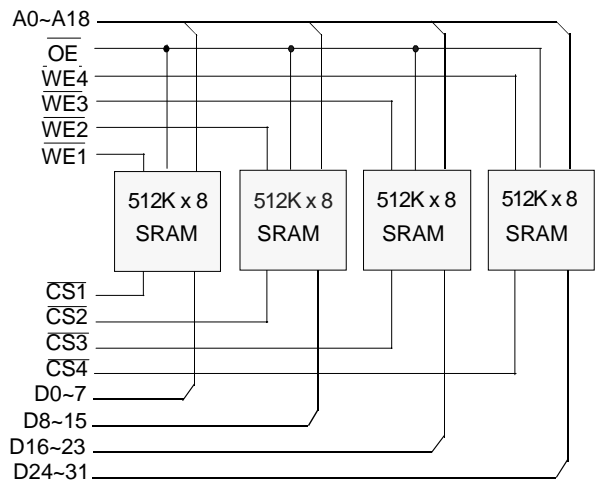

**Package Information** Dimensions in mm(inches)

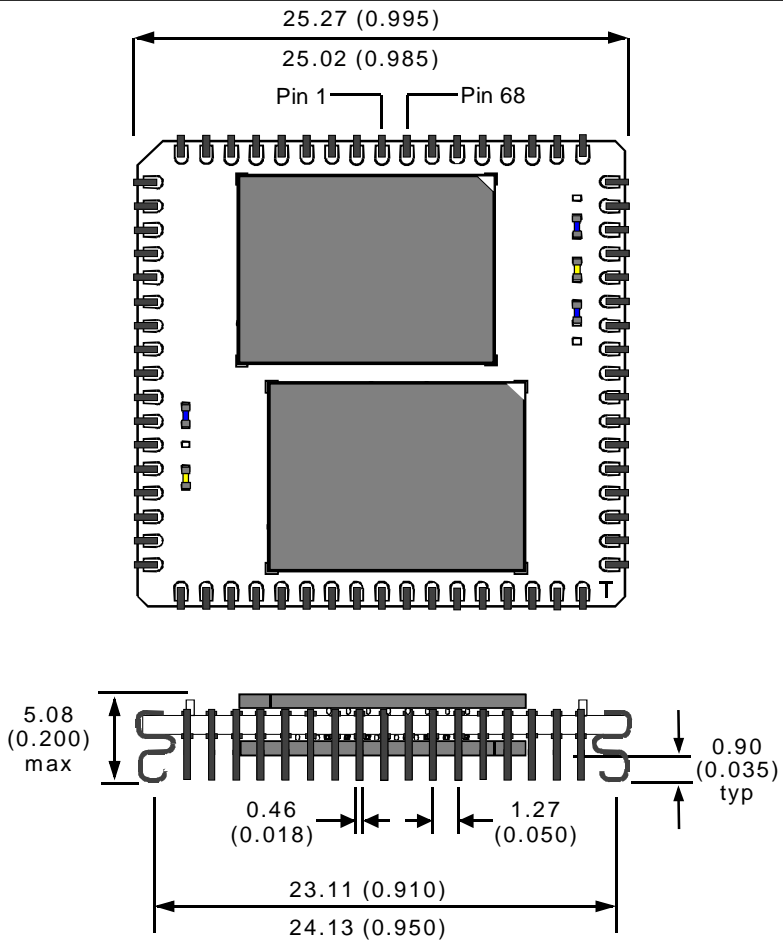

**Ordering Information**

**PUMA 68S16000ABM-020**

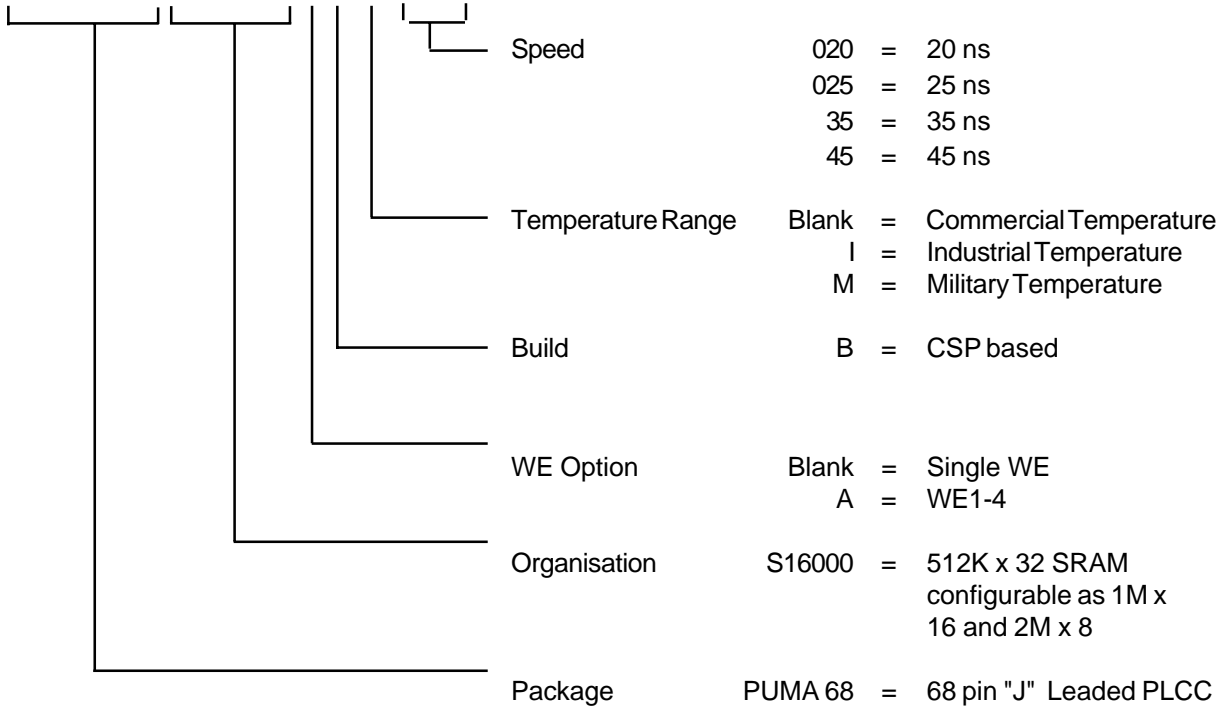

Although this data is believed to be accurate the information contained herein is not intended to and does not create any warranty of merchantability or fitness for a particular purpose. Products are subject to a constant process of development. Data may be changed at any time without notice. Products are not authorised for use as critical components in life support devices or systems without the express written approval of a company director

## Moisture Sensitivity

Devices are **moisture sensitive**.

Shelf Life in Sealed Bag 12 months at <40°C and <90% relative humidity (RH).

After this bag has been opened, devices that will be subjected to infrared reflow, vapour phase reflow, or equivalent processing (peak package body temp 220°C) **must be** :

A : Mounted within 72 Hours at factory conditions of <30°C/60% RH

**OR**

B : Stored at <20% RH

If these conditions are not met or indicator card is >20% when read at 23°C +/-5% devices **require baking** as specified below.

If baking is required, devices may be baked for :-

A : 24 hours at 125°C +/-5% for high temperature device containers

**OR**

B : 192 hours at 40°C +5°C/-0°C and <5% RH for low temperature device containers.

## Packaging Standard

Packaged in trays as standard.

Tape and reel available for shipment quantities exceeding 200pcs upon request.

## Soldering Recommendations

IR/Convection-	Ramp Rate	6°C/sec max.
	Temp. exceeding 183°C	150 secs. max.
	Peak Temperature	225°C
	Time within 5°C of peak	20 secs max.
	Ramp down	6°C/sec max.
Vapour Phase-	Ramp up rate	6°C/sec max.
	Peak Temperature	215 - 219°C
	Time within 5°C of peak	60 secs max.
	Ramp down	6°C/sec max.

*Note : The above recommendations are based on standard industry practice. Failure to comply with the above recommendations invalidates product warranty.*