



32K x 32 SRAM MODULE

PUMA 2S1000 - 025/35/45

Elm Road, West Chirton, North Shields, Tyne and Wear, NE29 8SE
 England, Tel. +44 (0191) 2930500 Fax. +44 (0191) 2590997

Issue 4.5 : August 2002

Description

The PUMA 2S1000 is a 1Mbit high speed static RAM organised as 32K x 32 in a 66 pin ceramic PGA package. Access times of 25ns, 35ns or 45ns are available. The device has a user configurable output width by 8, 16 or 32 bits, and features a low power standby mode with 3.0V battery back-up capability. The package includes on board decoupling capacitors and is suitable for thermal ladder operations. It may be screened in accordance with MIL-STD-883.

1,048,576 bit CMOS High Speed Static RAM

Features

- Very Fast Access times of 25/35/45 ns.
- User Configurable as 8 / 16 / 32 bit wide output.
- Operating Power 1.6 W (max) 8 bit
- Low Power Standby 50 mW (max) - L Version
- Upgradeable Package.
- Package Suitable for Thermal Ladder Applications.
- On board decoupling capacitors.
- Low voltage data retention.
- May be screened in accordance with MIL-STD-883.

Block Diagram

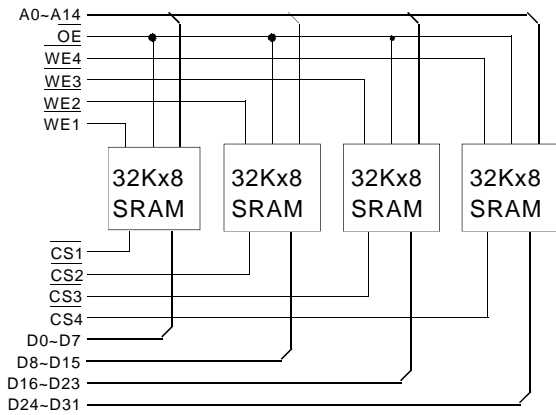

Pin Definition

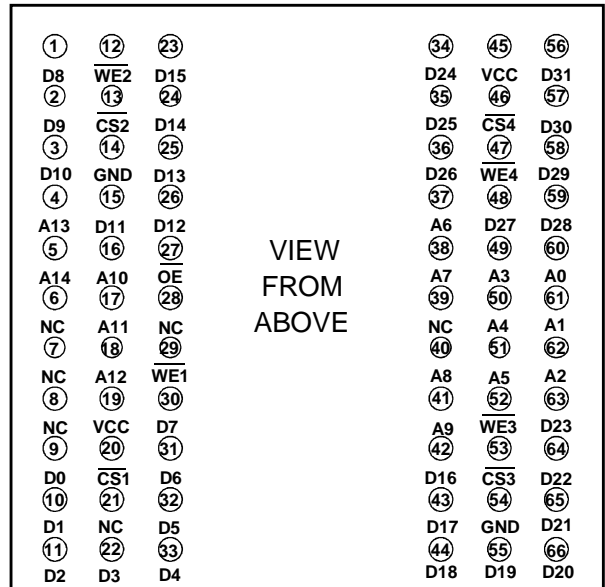

Pin Functions

A0~A14 Address Inputs
CS1~4 Chip Select
WE1~4 Write Enable
V_{CC} Power (+5V)

D0~D31 Data Inputs/Outputs
OE Output Enable
NC No Connect
GND Ground

DC OPERATING CONDITIONS**Absolute Maximum Ratings** ⁽¹⁾

Voltage on any pin relative to V_{SS} ⁽²⁾	V_T	-0.5V to +7.0	V
Power Dissipation	P_T	4	W
Storage Temperature	T_{STG}	-65 to +150	°C

Notes : (1) Stresses above those listed may cause permanent damage to the device. This is a stress rating only and functional operation of the device at these or any other conditions above those indicated in the operational sections of this specification is not implied. Exposure to absolute maximum rating conditions for extended periods may affect device reliability.

Recommended Operating Conditions

Parameter	Symbol	min	typ ⁽¹⁾	max	Unit
Supply Voltage	V_{CC}	4.5	5.0	5.5	V
Input High Voltage	V_{IH}	2.2	-	$V_{CC}+0.5$	V
Input Low Voltage	V_{IL}	-0.5	-	0.8	V
Operating Temperature	T_A	0	-	70	°C
	T_{AI}	-40	-	85	°C (I suffix)
	T_{AM}	-55	-	125	°C (M, MB suffix)

DC Electrical Characteristics ($V_{CC}=5V\pm 10\%$, $T_A=-55^\circ\text{C}$ to $+125^\circ\text{C}$)

Parameter	Symbol	Test Condition	min	typ ⁽¹⁾	max	Unit
I/P Leakage Current	I_{LI1}	$V_{IN}=0V$ to V_{CC}	-8	-	8	μA
Output Leakage Current	8 bit I_{LO}	$\overline{CS}^{(2)}=V_{IH}$ or $\overline{OE}=V_{IH}$, $V_{IO}=0V$ to V_{CC} , $\overline{WE}^{(2)}=V_{IL}$	-8	-	8	μA
Average Supply Current	32 bit I_{CC32}	$\overline{CS}^{(2)}=V_{IL}$, Min. cycle, $I_{IO}=0\text{mA}$, 100% Duty.	-	-	660	mA
	16 bit I_{CC16}	As above	-	-	410	mA
	8 bit I_{CC8}	As above	-	-	285	mA
Standby Supply Current	TTL I_{SB}	$\overline{CS}^{(2)}=V_{IH}$, Min Cycle.	-	-	160	mA
	-L Version I_{SB2}	$\overline{CS}^{(2)}\geq V_{CC}-0.2V$, $0.2V\geq V_{IN}\geq V_{CC}-0.2V$	-	-	9	mA
Output Voltage Low	V_{OL}	$I_{OL}=8.0\text{mA}$	-	-	0.4	V
Output Voltage High	V_{OH}	$I_{OH}=-4.0\text{mA}$	2.4	-	-	V

Notes: \overline{CS} and \overline{WE} above are accessed through $\overline{CS}1\sim 4$ and $\overline{WE}1\sim 4$ respectively. These inputs must be operated simultaneously for 32 bit mode, in pairs for 16 bit mode and singly for 8 bit mode.

Capacitance ($V_{CC}=5V\pm 10\%$, $T_A=25^\circ\text{C}$)

Parameter	Symbol	Test Condition	typ	max	Unit
Input Capacitance	C_{IN}	$V_{IN}=0V$	-	38	pF
I/O Capacitance:	C_{IO}	$V_{IO}=0V$	-	18	pF

Note: This parameter is calculated and not measured.

Operating Modes

The Table below shows the logic inputs required to control the operating modes of each of the SRAMs on the PUMA 2S1000.

Mode	\overline{CS}	\overline{OE}	\overline{WE}	V_{CC} Current	I/O Pin	Reference Cycle
Not Selected	1	X	X	I_{SB1}, I_{SB2}	High Z	Power Down
Output Disable	0	1	1	I_{CC}	High Z	
Read	0	0	1	I_{CC}	D_{OUT}	Read Cycle
Write	0	X	0	I_{CC}	D_{IN}	Write Cycle

1 = V_{IH} , 0 = V_{IL} , X = Don't Care

Note: \overline{CS} is accessed through $\overline{CS1-4}$, and \overline{WE} is accessed through $\overline{WE1-4}$. For correct operation, $\overline{CS1-4}$ must operate simultaneously for 32 bit operation, in pairs for 16 bit operation, or singly for 8 bit operation. $\overline{WE1-4}$ must also be operated in the same manner.

Low V_{CC} Data Retention Characteristics - L Version Only ($V_{CC} = 5.0V \pm 10\%$, $T_A = -55^\circ C$ to $+125^\circ C$)

Parameter	Symbol	Test Condition	min	typ	max	Unit
V_{CC} for Data Retention	V_{DR}	$\overline{CS} \geq V_{CC} - 0.2V, V_{IN} \geq 0V$	2.0	-	5.5	V
Data Retention Current	I_{CCDR1}	$V_{CC} = 2.0V, \overline{CS} \geq V_{CC} - 0.2V, V_{IN} \geq 0V$	-	-	8	mA
-L Version	I_{CCDR2}	As above	-	-	2.2	mA
Chip Deselect to Data Retention Time	t_{CDR}	See Retention Waveform	0	-	-	ns
Operation Recovery Time	t_R	See Retention Waveform	t_{RC}	-	-	ns

Note: \overline{CS} above is accessed through $\overline{CS1-4}$.

AC Test Conditions

- * Input pulse levels: 0V to 3.0V
- * Input rise and fall times: 3ns
- * Input and Output timing reference levels: 1.5V
- * Output load: see diagram
- * $V_{CC} = 5V \pm 10\%$

Output Load

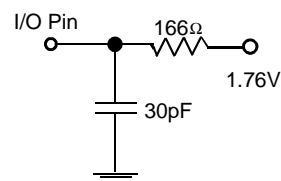

AC OPERATING CONDITIONS

<i>Parameter</i>	<i>Symbol</i>	25		35		45		<i>Unit</i>
		<i>min</i>	<i>max</i>	<i>min</i>	<i>max</i>	<i>min</i>	<i>max</i>	
Read Cycle Time	t_{RC}	25	-	35	-	45	-	ns
Address Access Time	t_{AA}	-	25	-	35	-	45	ns
Chip Select Access Time	t_{ACS}	-	25	-	35	-	45	ns
Output Enable to Output Valid	t_{OE}	-	12	-	15	-	20	ns
Output Hold from Address Change	t_{OH}	5	-	5	-	5	-	ns
Chip Selection to Output in Low Z	t_{CLZ}	6	-	6	-	6	-	ns
Output Enable to Output in Low Z	t_{OLZ}	0	-	0	-	0	-	ns
Chip Deselection to Output in High Z ⁽³⁾	t_{CHZ}	0	12	0	15	0	20	ns
Output Disable to Output in High Z ⁽³⁾	t_{OHZ}	0	12	0	15	0	20	ns

<i>Parameter</i>	<i>Symbol</i>	25		35		45		<i>Unit</i>
		<i>min</i>	<i>max</i>	<i>min</i>	<i>max</i>	<i>min</i>	<i>max</i>	
Write Cycle Time	t_{WC}	25	-	35	-	45	-	ns
Chip Selection to End of Write	t_{CW}	20	-	30	-	40	-	ns
Address Valid to End of Write	t_{AW}	20	-	30	-	40	-	ns
Address Setup Time	t_{AS}	0	-	0	-	0	-	ns
Write Pulse Width	t_{WP}	15	-	20	-	25	-	ns
Write Recovery Time	t_{WR}	0	-	0	-	0	-	ns
Write to Output in High Z	t_{WHZ}	0	15	0	18	0	20	ns
Data to Write Time Overlap	t_{DW}	20	-	20	-	20	-	ns
Data Hold from Write Time	t_{DH}	0	-	0	-	0	-	ns
Output Active from End of Write	t_{OW}	5	-	5	-	5	-	ns

Read Cycle 1 Timing Waveform ⁽¹⁾

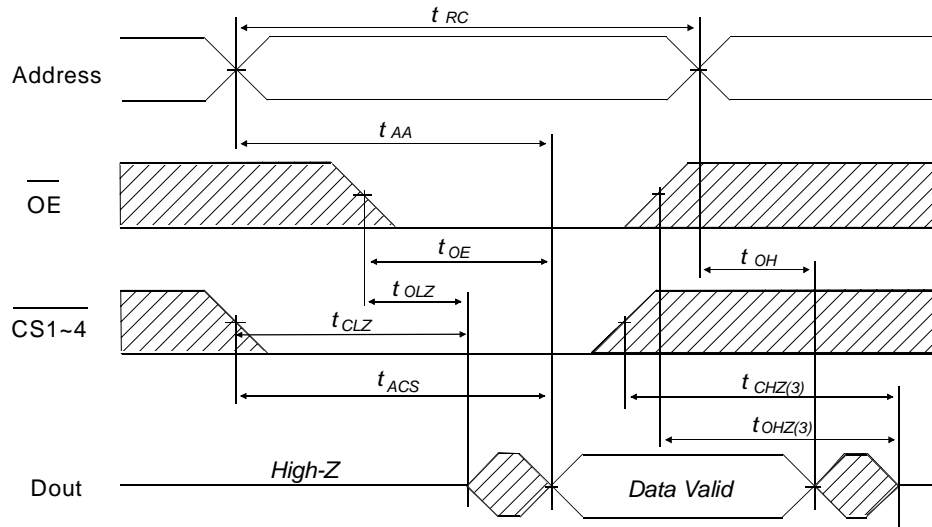

Read Cycle 2 Timing Waveform ^{(1) (2) (4)}

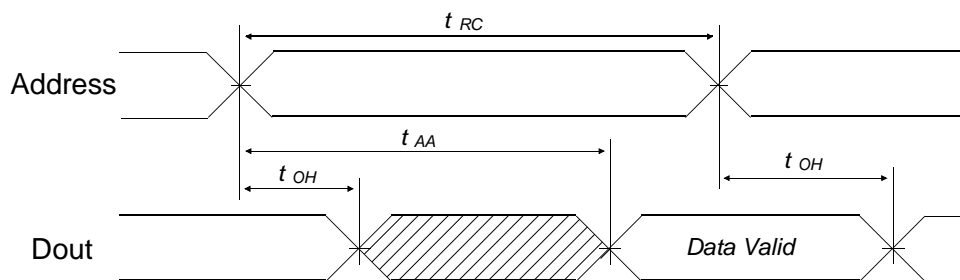

- Notes: (1) $\overline{WE1-4}$ is High for Read Cycle.
 (2) Device is continuously selected, $\overline{CS1-4}=V_{IL}$.
 (3) t_{CHZ} and t_{OHZ} are defined as the time at which the outputs achieve the open circuit conditions and are not referenced to output voltage levels. These parameters are sampled and not 100% tested.
 (4) $\overline{OE}=V_{IL}$.

Write Cycle No.1 Timing Waveform

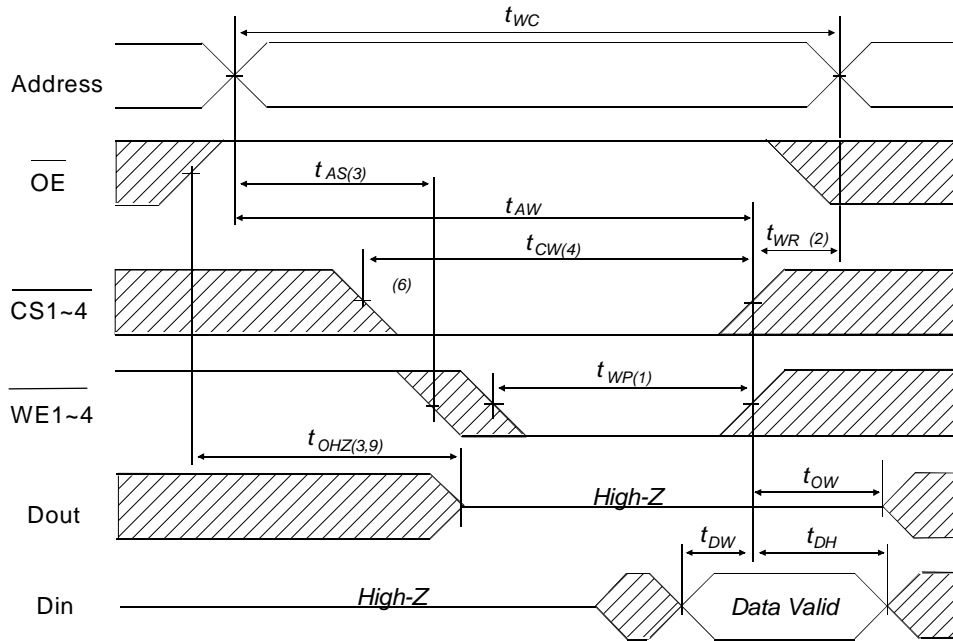

Write Cycle No.2 Timing Waveform ⁽⁵⁾

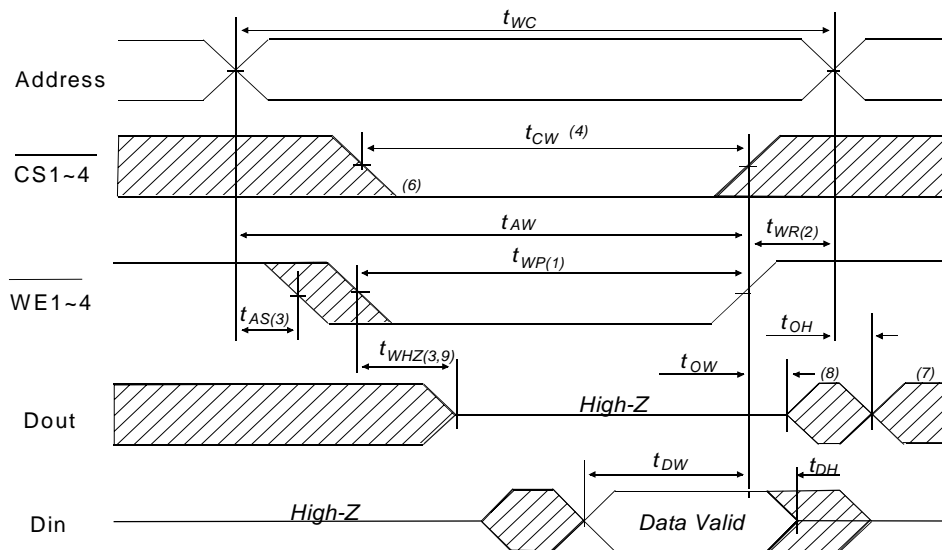

Data Retention Waveform

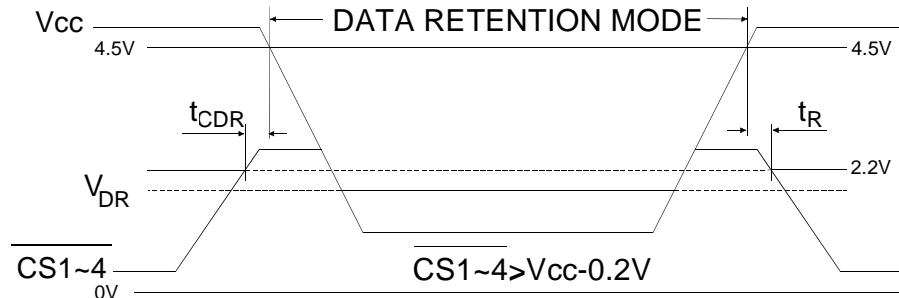

AC Write Characteristics Notes

- (1) A write occurs during the overlap (t_{WP}) of a low \overline{CS} and a low \overline{WE} .
- (2) t_{WR} is measured from the earlier of \overline{CS} or \overline{WE} going high to the end of write cycle.
- (3) During this period, I/O pins are in the output state. Input signals out of phase must not be applied.
- (4) If the \overline{CS} low transition occurs simultaneously with the \overline{WE} low transition or after the \overline{WE} low transition, outputs remain in a high impedance state.
- (5) \overline{OE} is continuously low. ($\overline{OE}=V_{IL}$)
- (6) Dout is in the same phase as written data of this write cycle.
- (7) Dout is the read data of next address.
- (8) If \overline{CS} is low during this period, I/O pins are in the output state. Input signals out of phase must not be applied to I/O pins.
- (9) t_{WHZ} and t_{OHZ} is defined as the time at which the outputs achieve the open circuit conditions and is not referenced to output voltage levels. This parameter is sampled and not 100% tested.

\overline{CS} and \overline{WE} above refer to $\overline{CS1-4}$ and $\overline{WE1-4}$ respectively.

PACKAGE DETAILS

66 Pin Ceramic PGA

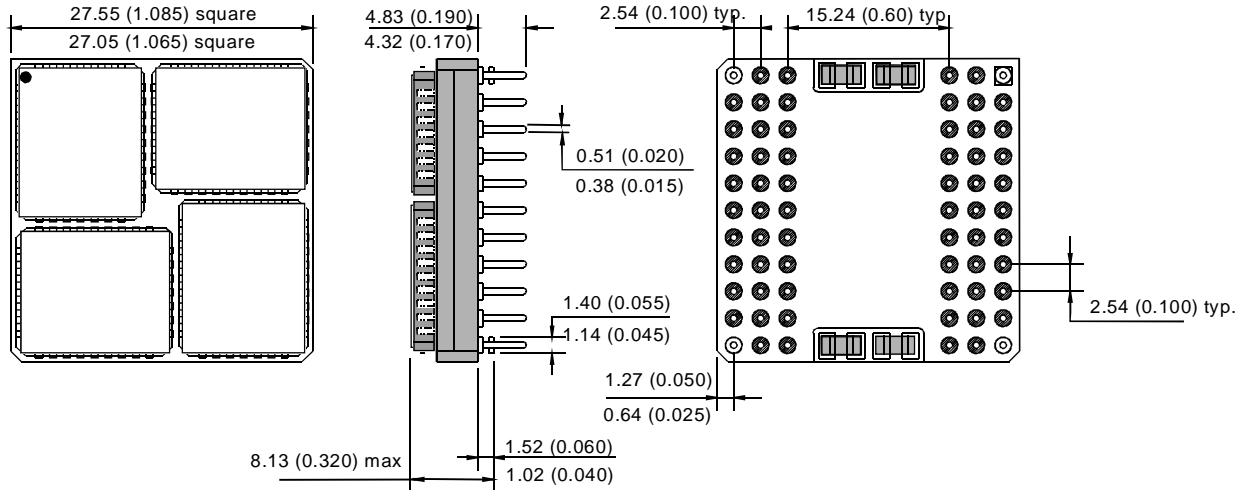

Dimensions in mm (inches)

SCREENING

Military Screening Procedure

Module Screening Flow for high reliability product is in accordance with Mil-883 method 5004 .

MB MODULE SCREENING FLOW		
SCREEN	TEST METHOD	LEVEL
Visual and Mechanical External visual Temperature cycle	2017 Condition B or manufacturers equivalent 1010 Condition C (10 Cycles, -65°C to +150°C)	100% 100%
Burn-In Pre-Burn-in electrical Burn-in	Per applicable Device Specifications at $T_A=+25^\circ\text{C}$ $T_A=+125^\circ\text{C}$, 160hrs minimum.	100% 100%
Final Electrical Tests Static (DC) Functional Switching (AC)	Per applicable Device Specification a) @ $T_A=+25^\circ\text{C}$ and power supply extremes b) @ temperature and power supply extremes a) @ $T_A=+25^\circ\text{C}$ and power supply extremes b) @ temperature and power supply extremes a) @ $T_A=+25^\circ\text{C}$ and power supply extremes b) @ temperature and power supply extremes	100% 100% 100% 100% 100% 100%
Percent Defective allowable (PDA)	Calculated at Post Burn-in at $T_A=+25^\circ\text{C}$	10%
Quality Conformance	Per applicable Device Specification	Sample
External Visual	2009 Per vendor or customer specification	100%

ORDERING INFORMATION

PUMA 2S1000LMB - 35

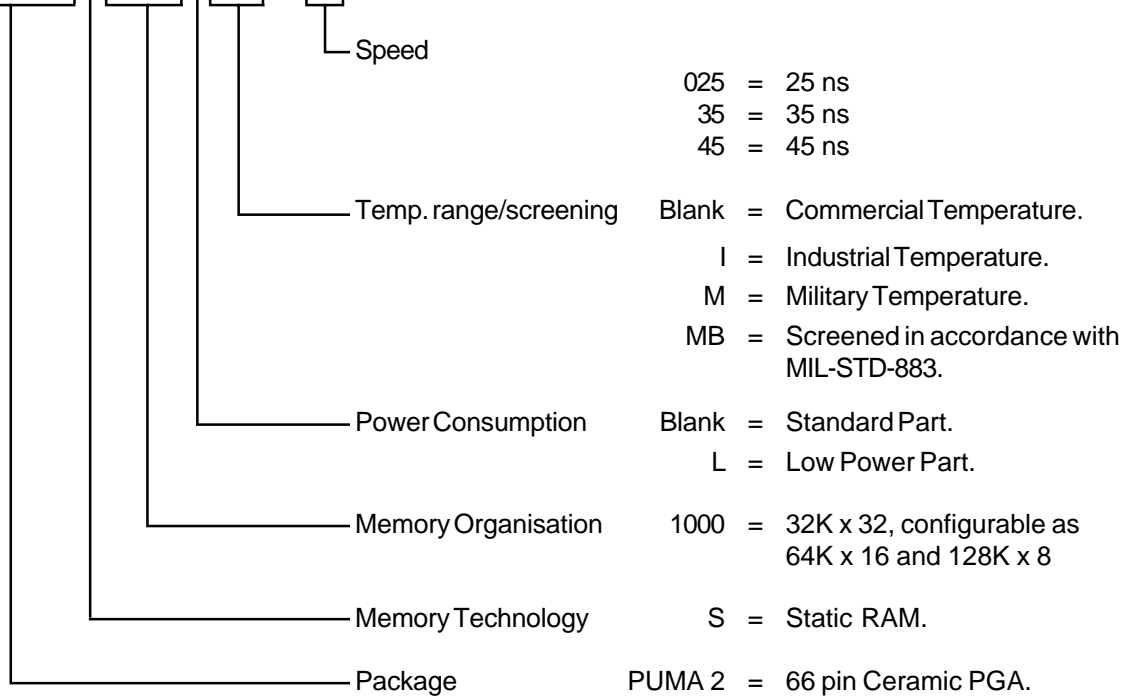

Note :

Although this data is believed to be accurate, the information contained herein is not intended to and does not create any warranty of merchantability or fitness for a particular purpose. Our products are subject to a constant process of development. Data may be changed at any time without notice. Products are not authorised for use as critical components in life support devices without the express written approval of a company director.