

**TRAILING EDGE PRODUCT - MINIMUM ORDER APPLIES.  
PRODUCT MAY BE MADE OBSOLETE WITHOUT NOTICE**



**128K x 8 FLASH**

**MFM8126 - 70/90/12**

Elm Road, West Chirton, NORTH SHIELDS, Tyne & Wear  
NE29 8SE, England Tel. +44 (0191) 2930500 Fax. +44 (0191) 2590997

Issue 4.3 : April 2001

**General Description**

The MFM8126 is a 1Mbit CMOS 5.0V only FLASH memory arranged as 128K X 8.

Flash memory combines the functionality of EEPROM with on board electrical Write/Erase, which reliably stores data even after 10,000 cycles. The device incorporates Automatic Programming and Erase functions, thus simplifying the external control circuitry.

In addition, a Sector Erase function is available which can erase one 16K block of data randomly and more than one block simultaneously. The MFM8126 also features hardware sector protection, which enables both program and erase operations in any of the 8 sectors.

**Features**

- Fast Access Time of 70 / 90 / 120ns.
- Operating Power Read 182mW (Max)  
Program/Erase 305mW (Max)  
Standby Power 6.4mW (Max)
- JEDEC standard package.
- Flexible Sector Erase Architecture - 16K byte sector size, with hardware protection of any number of sectors.
- Single Byte Program of 14µs (typical), Sector Program / Verify time of 0.3 sec. (typical).
- Device FLASH Erase / Verify of 3 seconds (typical).
- Erase/Write Cycle Endurance 10,000 (minimum)
- Extended endurance (E) option
- Can be screened in accordance with MIL-STD-883.

**Block Diagram**

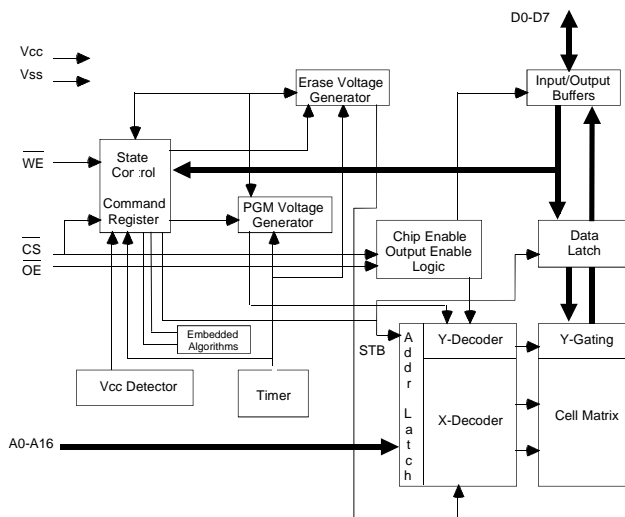

**Pin Definitions**

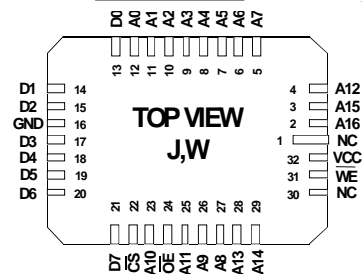
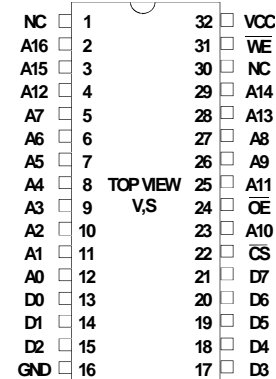

**Pin Functions**

- A0-A16 Address Inputs
- D0-D7 Data Inputs/Outputs
- CS Chip Enable
- WE Write Enable
- OE Output Enable
- Vcc Power (+5V)
- GND Ground

**Package Details**

Pin Count	Description	Package Type
32	0.1" Vertical-in-line (VIL™)	V
32	Leadless Chip Carrier (LCC)	W

**DC Operating Conditions****Absolute Maximum Ratings** <sup>(1)</sup>

	<i>max</i>	<i>unit</i>
Voltage on any pin w.r.t. Gnd <sup>(2)</sup> (except A9)	-2.0 to +7	V
Supply Voltage <sup>(2)</sup>	-2.0 to +7	V
Voltage on A <sub>9</sub> w.r.t. Gnd	-2.0 to +14	V
Storage Temperature	-55 to +150	°C

Notes : (1) Stresses above those listed may cause permanent damage to the device. This is a stress rating only and functional operation of the device at those or any other conditions above those indicated in the operational sections of this specification is not implied.

(2) Minimum DC voltage on any input or I/O pin is -0.5V. Maximum DC voltage on output and I/O pins is  $V_{CC}+0.5V$ . During transitions voltage may overshoot by +/-1V for upto 10ns

**Recommended Operating Conditions**

<i>Parameter</i>	<i>Symbol</i>	<i>min</i>	<i>typ</i>	<i>max</i>	<i>unit</i>
Supply Voltage	$V_{CC}$	4.5	5.0	5.5	V
Input High Voltage	TTL $V_{IH}$	2.0	-	$V_{CC}+0.5$	V
	CMOS $V_{IHC}$	$0.7 V_{CC}$	-	$V_{CC}+0.5$	V
Input Low Voltage	TTL $V_{IL}$	-0.5	-	0.8	V
	CMOS $V_{ILC}$	-0.5	-	0.8	V
Operating Temperature	$T_A$	0	-	70	°C
	$T_{AI}$	-40	-	85	°C (-I suffix)
	$T_{AM}$	-55	-	125	°C (-M, MB suffix)

**DC Electrical Characteristics** ( $T_A = -55^{\circ}C$  to  $+125^{\circ}C$ ,  $V_{CC} = 5V \pm 10\%$ )

<i>Parameter</i>	<i>Symbol</i>	<i>Test Condition</i>	<i>min</i>	<i>typ</i>	<i>max</i>	<i>Unit</i>
Input Leakage Current	$I_{LI}$	$V_{IN}=0$ to $V_{CC}$ , $V_{CC} = V_{CC} \text{ max.}$	-	-	$\pm 2$	$\mu A$
Output Leakage Current	$I_{LO}$	$V_{OUT}=0$ to $V_{CC}$ , $V_{CC} = V_{CC} \text{ max.}$	-	-	$\pm 2$	$\mu A$
Standby Supply Current	TTL $I_{SB1}$	$\overline{CS}=V_{IH}$ , $V_{CC} = V_{CC} \text{ max.}$	-	-	1.15	mA
	CMOS $I_{SB2}$	$\overline{CS}=V_{CC}+0.5$ , $V_{CC} = V_{CC} \text{ max.}$	-	-	115	$\mu A$
Operating Current	Read $I_{CC1}$	$\overline{CS} = V_{IL}$ , $\overline{OE} = V_{IH}$	-	-	33	mA
	Program/Erase $I_{CC2}$	$\overline{CS} = V_{IL}$ , $\overline{OE} = V_{IH}$	-	-	55	mA
Output Low Voltage	$V_{OL}$	$I_{OL}=12mA$ , $V_{CC} = V_{CC} \text{ min.}$	-	-	0.45	V
Output High Voltage	$V_{OH}$	$I_{OH}=-2.5mA$ , $V_{CC} = V_{CC} \text{ min.}$	2.4	-	-	V
Low Vcc lock out voltage	$V_{LKO}$		3.2	-	-	V
A9 voltage for autoselect	$V_{ID}$	$V_{CC} = 5.0V$	11.5	-	12.5	V

**Capacitance** ( $T_A = 25^{\circ}C$ ,  $f = 1MHz$ )

<i>Parameter</i>	<i>Symbol</i>	<i>Test Condition</i>	<i>typ</i>	<i>max</i>	<i>Unit</i>
Input Capacitance:	$C_{IN}$	$V_{IN}=0V$	6	7.5	pF
Output Capacitance:	$C_{OUT}$	$V_{OUT}=0V$	8.5	12	pF

Note: Capacitance calculated not measured.

## AC Test Conditions

- \* Input pulse levels : 0.0V to 3.0V
- \* Input rise and fall times : 5 ns
- \* Input and output timing reference levels : 1.5V
- \* VCC = 5V +/- 10%

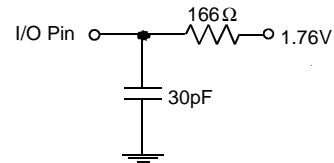

## Operating Modes

The following modes are used to control the MFM8126

OPERATION	$\overline{\text{CS}}$	$\overline{\text{OE}}$	$\overline{\text{WE}}$	A <sub>0</sub>	A <sub>1</sub>	A <sub>9</sub>	I/O
Auto-Select Manufacturer Code	L	L	H	L	L	VID	Code
Auto Select Device Code	L	L	H	H	L	VID	Code
Read	L	L	H	A0	A1	A9	Dout
Standby	H	X	X	X	X	X	High Z
Output Disable	L	H	H	X	X	X	High Z
Write	L	H	L	A0	A1	A9	Din
Enable Sector Protect	L	VID	L	X	X	VID	X
Verify Sector Protect	L	L	H	L	H	VID	Code

**AC Operating Conditions****Read**

Parameter	Symbol	-70		-90		-12		unit
		min	max	min	max	min	max	
Read Cycle Time	$t_{RC}$	70	-	90	-	120	-	ns
Address to output delay	$t_{AC}$	-	70	-	90	-	120	ns
Chip Select to output	$t_{CE}$	-	70	-	90	-	120	ns
Output Enable to output	$t_{OE}$	-	30	-	35	-	50	ns
Chip Select to O/P High Z	$t_{DF}$	-	20	-	20	-	30	ns
Output Enable to output High Z	$t_{DF}$	-	20	-	20	-	30	ns
Output hold time (From address, $\overline{CS}$ or $\overline{OE}$ whichever occurs first)	$t_{OH}$	0	-	0	-	0	-	ns

**Write/ Erase/ Program**

Parameter	Symbol	-70		-90		-12		unit
		min	max	min	max	min	max	
Write Cycle time	$t_{WC}$	70	-	90	-	120	-	ns
Address Setup time	$t_{AS}$	0	-	0	-	0	-	ns
Address Hold time	$t_{AH}$	45	-	45	-	50	-	ns
Data Setup Time	$t_{DS}$	30	-	40	-	50	-	ns
Data hold Time	$t_{DH}$	0	-	0	-	0	-	ns
Output Enable Setup Time	$t_{OES}$	0	-	0	-	0	-	ns
Output Enable Hold Time	$t_{OEH}$	0	-	0	-	0	-	ns
Read Recover before Write	$t_{GHWL}$	0	-	0	-	0	-	ns
$\overline{CS}$ setup time	$t_{CS}$	0	-	0	-	0	-	ns
$\overline{CS}$ hold time	$t_{CH}$	0	-	0	-	0	-	ns
Write Pulse Width	$t_{WP}$	35	-	40	-	50	-	ns
Write Pulse Width High	$t_{WPH}$	20	-	20	-	20	-	ns
Programming operation	$t_{WHWH1}$	14	-	14	-	14	-	$\mu$ s
Erase operation <sup>(1)</sup>	$t_{WHWH2}$	3	60	3	60	3	60	s
Vcc setup time <sup>(4)</sup>	$t_{VCS}$	50	-	50	-	50	-	$\mu$ s
Voltage Transition Time <sup>(2,4)</sup>	$t_{VLHT}$	4	-	4	-	4	-	ns
Write Pulse Width <sup>(2)</sup>	$t_{WPP}$	10	-	10	-	10	-	ns
$\overline{OE}$ Setup time to $\overline{WE}$ active <sup>(2,4)</sup>	$t_{OESP}$	4	-	4	-	4	-	ns
$\overline{CS}$ Setup time to $\overline{WE}$ active <sup>(3,4)</sup>	$t_{CSP}$	4	-	4	-	4	-	ns

- Notes:
- (1) This also includes the preprogramming time.
  - (2) These timings are for Sector Protect/Unprotect operations.
  - (3) This timing is only for Sector Unprotect.
  - (4) Not 100% tested.

Write/Erase/Program (Alternate $\overline{\text{CS}}$ controlled Writes)								
--	--	--	--	--	--	--	--	--

Parameter	Symbol	-70		-90		-12		unit
		min	max	min	max	min	max	
Write Cycle time	$t_{\text{WC}}$	70	-	90	-	120	-	ns
Address Setup time	$t_{\text{AS}}$	0	-	0	-	0	-	ns
Address Hold time	$t_{\text{AH}}$	45	-	45	-	50	-	ns
Programming operation	$t_{\text{DS}}$	30	-	40	-	50	-	ns
Data hold Time	$t_{\text{DH}}$	0	-	0	-	0	-	ns
Output Enable Setup Time	$t_{\text{OES}}$	0	-	0	-	0	-	ns
Output Enable Hold Time	$t_{\text{OEH}}$	0	-	0	-	0	-	ns
Read Recover before Write	$t_{\text{GHREL}}$	0	-	0	-	0	-	ns
$\overline{\text{WE}}$ setup time	$t_{\text{WS}}$	0	-	0	-	0	-	ns
$\overline{\text{WE}}$ hold time	$t_{\text{WH}}$	0	-	0	-	0	-	ns
$\overline{\text{CS}}$ Pulse Width	$t_{\text{CP}}$	35	-	40	-	50	-	ns
$\overline{\text{CS}}$ Pulse Width High	$t_{\text{CPH}}$	20	-	20	-	20	-	ns
Programming operation	$t_{\text{WHWH1}}$	14	-	14	-	14	-	$\mu\text{s}$
Erase operation <sup>(1)</sup>	$t_{\text{WHWH2}}$	3	60	3	60	3	60	s
Vcc setup time <sup>(2)</sup>	$t_{\text{VCS}}$	2	-	2	-	2	-	$\mu\text{s}$

Notes: (1) This also includes the preprogramming time.  
(2) Not 100% tested.



**AC Chip / Sector Erase Waveforms**

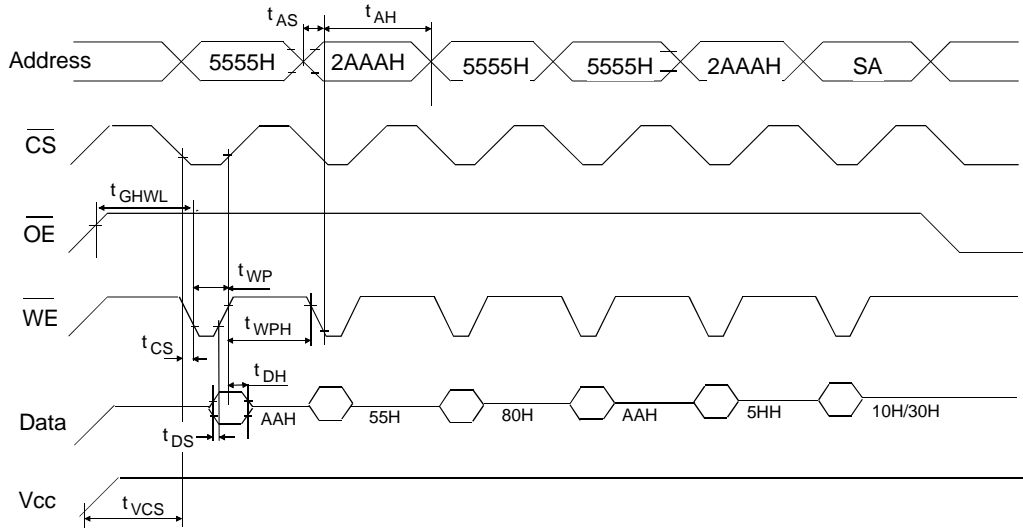

**NOTES:**

- 1. SA is the address for Sector Erase. Addresses = don't care for Chip Erase.

**AC Waveforms for Data Polling During Embedded Algorithm Operations**

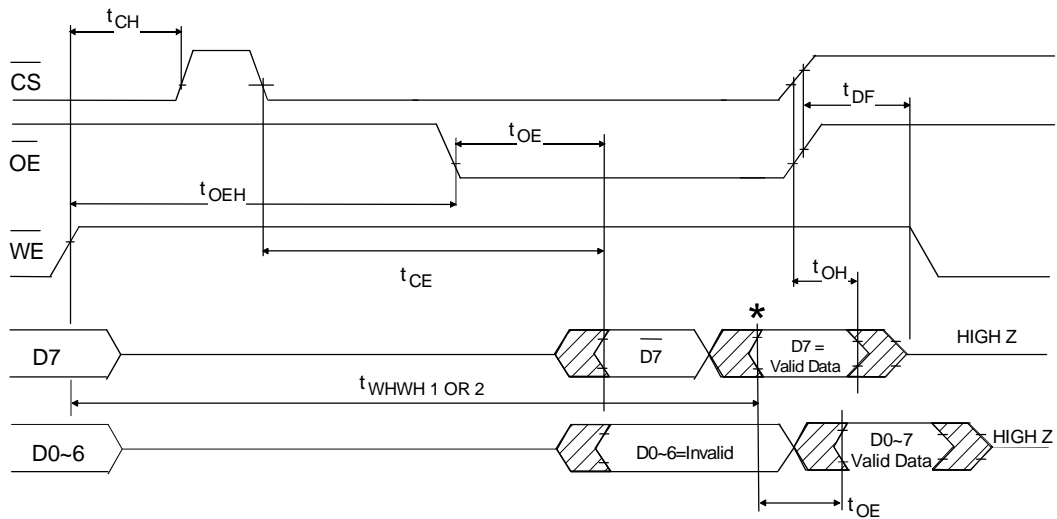

\* D7 = Valid data (The device has completed the Embedded Operation).

**AC Waveforms for Toggle Bit During Embedded Algorithm Operations**

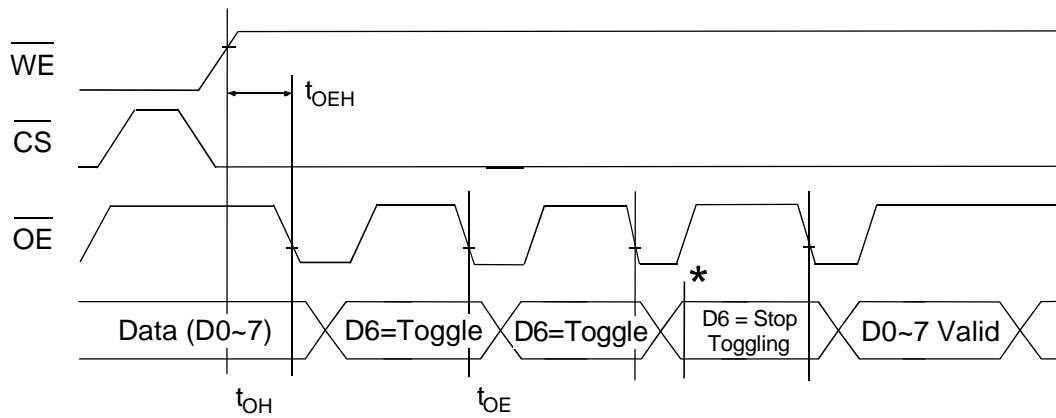

D<sub>6</sub> stops toggling (The device has completed the Embedded operation).

**AC Waveforms For Sector Protection**

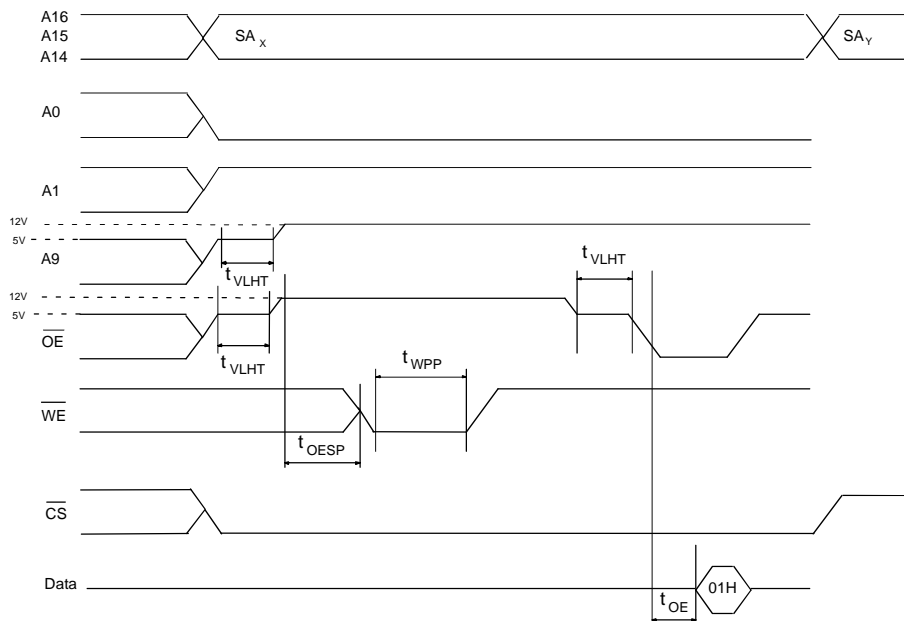

SAX = sector Addr for initial sector  
 SAY = sector Addr for next sector

**AC Waveforms for Sector Unprotect**

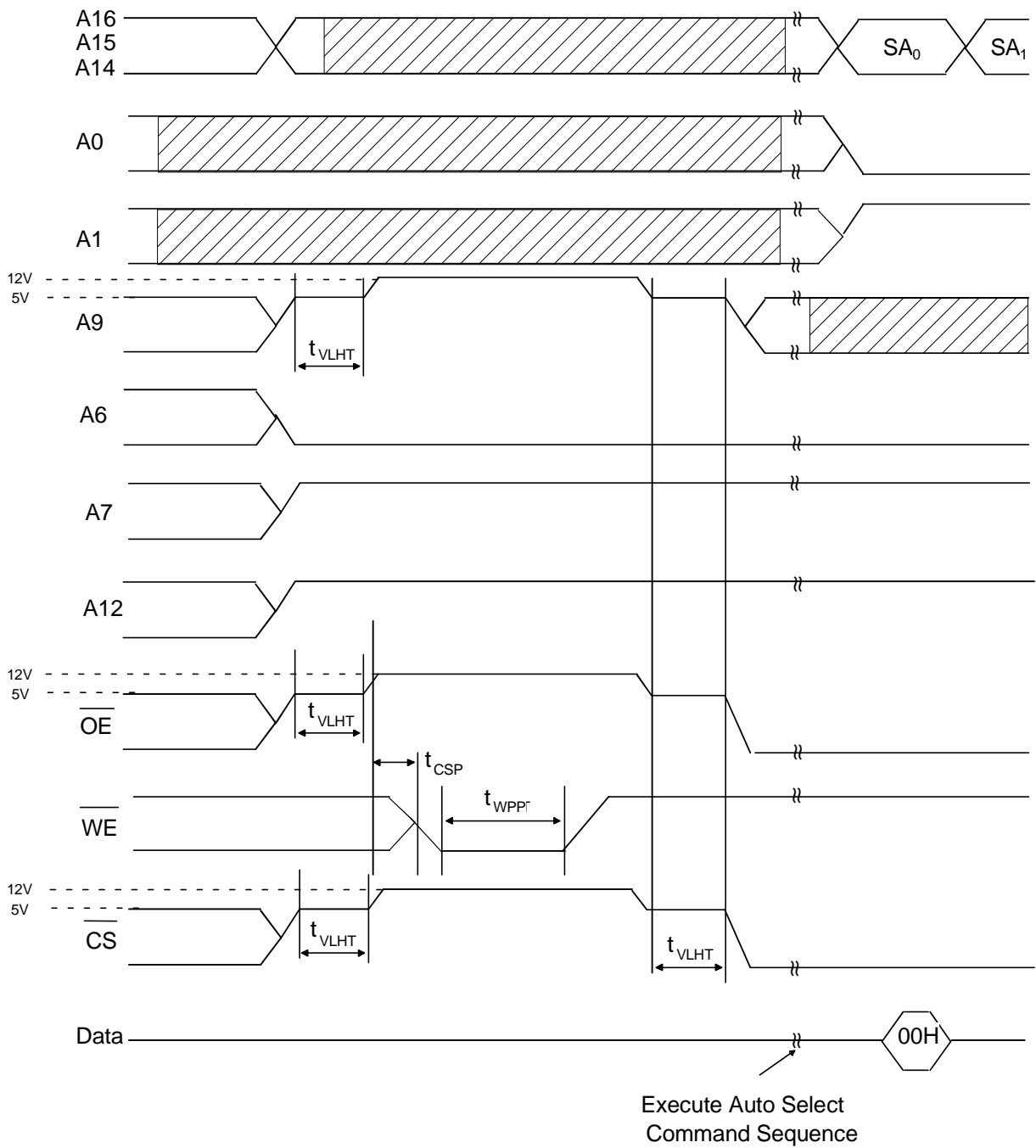

A.C Waveforms - Alternate  $\overline{CS}$  controlled Program operation timings

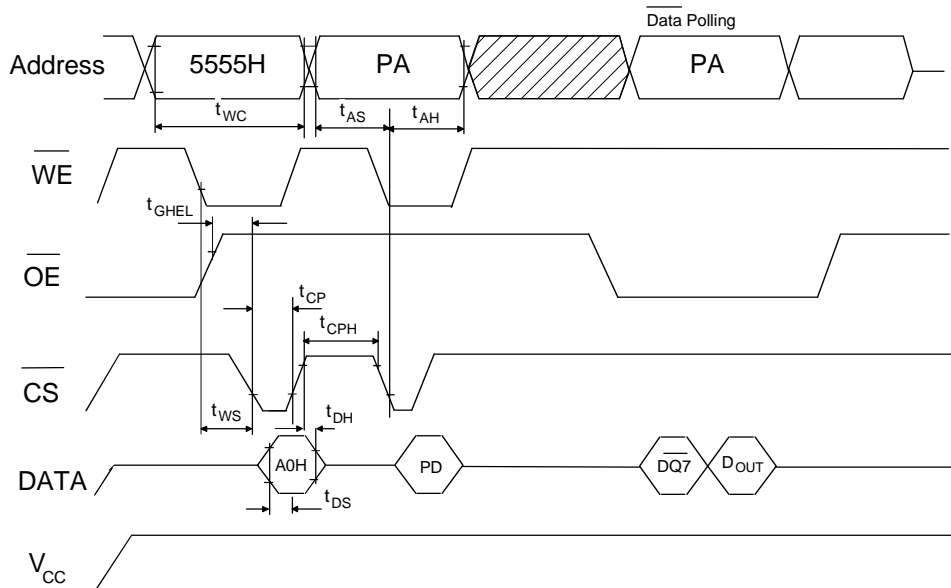

**NOTES:**

1. PA is address of memory location to be programmed.
2. PD is data to be programmed at byte address.
3.  $\overline{D_7}$  is the output of the complement of the data written to the device.
4.  $D_{OUT}$  is the output of the data written to the device.
5. Figure indicates last two bus cycles of four bus cycle sequence.

## Command Definitions

Device operations are selected by writing specific address and data sequences into the command register. The following table defines these register command sequences.

COMMAND SEQUENCE	Bus Write Cycle Req'd	First Bus Write Cycle		Second Bus Write Cycle		Third bus Write Cycle		Fourth bus Read/Write Cycle		Fifth Bus Write Cycle		Sixth Bus Write Cycle	
		Addr	Data	Addr	Data	Addr	Data	Addr	Data	Addr	Data	Addr	Data
Read/Reset	4	5555H	AAH	2AAAH	55H	5555H	F0H	RA	RD				
Autoselect	4	5555H	AAH	2AAAH	55H	5555H	90H	00H/01H	01H/20H				
Byte Program	4	5555H	AAH	2AAAH	55H	5555H	A0H	PA	PD				
Chip erase	6	5555H	AAH	2AAAH	55H	5555H	80H	5555H	AAH	2AAAH	55H	5555H	10H
Sector erase	6	5555H	AAH	2AAAH	55H	5555H	80H	5555H	AAH	2AAAH	55H	SA	30H

### NOTES:

- Address bit  $A_{15}=X=$ Don't care. Write Sequences may be initiated with  $A_{15}$  in either state.
- Address bit  $A_{16}=X=$ Don't care for all address commands except for Program Address (PA) and Sector Address (SA).
- RA=Address of the memory location to be read.  
PA=Address of memory location to be programmed. Addresses are latched on the falling edge of the  $\overline{WE}$  pulse.  
SA=Address of the sector to be erased. The combination of  $A_{16}$ ,  $A_{15}$  and  $A_{14}$  will uniquely select any sector.
- RD=Data read from location RA during read operation.  
PD=Data to be programmed at location PA. Data is latched on the falling edge of  $\overline{WE}$

## Read/Reset Command

The read or reset operation is initiated by writing the read/reset command sequence into the command register. Microprocessor read cycles retrieve array data from the memory. The device remains enabled for reads until the command register contents are altered.

The device will automatically power-up in the read/reset state. In this case, a command sequence is not required to read data. Standard microprocessor read cycles will retrieve array data. This default value ensures that no spurious alteration of memory content occurs during the power transition. Refer to the AC Read Characteristics and Waveforms for specific timing parameters.

## Read Mode

The MFM8126 has two control functions which must be satisfied in order to obtain data at the outputs  
 $\overline{CS}$  is the power control and should be used for device selection  
 $\overline{OE}$  is the output control and should be used to gate data to the output pins if the device is selected.

## Standby Mode

Two standby modes are available :

CMOS standby :  $\overline{CS}$  held at  $V_{cc} \pm 0.5V$

TTL standby :  $\overline{CS}$  held at  $V_{IH}$

In the standby mode the outputs are in a high impedance state independent of the  $\overline{OE}$  input. If the device is deselected during erasure or programming the device will draw active current until the operation is completed.

## Output Disable

With the  $\overline{OE}$  input at a logic high level ( $V_{IH}$ ), output from the device is disabled. This will cause the output pins to be in a high impedance state.

## Autoselect

The autoselect mode allows the reading out of a binary code from the device and will identify the device manufacturer and type. This mode is intended for use by programming equipment. This mode is functional over the full military temperature range. The autoselect codes are as follows :

	A <sub>16</sub>	A <sub>15</sub>	A <sub>14</sub>	A <sub>1</sub>	A <sub>0</sub>	CODE (HEX)	D <sub>7</sub>	D <sub>6</sub>	D <sub>5</sub>	D <sub>4</sub>	D <sub>3</sub>	D <sub>2</sub>	D <sub>1</sub>	D <sub>0</sub>
DIE Manufacturer code	X	X	X	V <sub>IL</sub>	V <sub>IL</sub>	01H	0	0	0	0	0	0	0	1
DIE device code	X	X	X	V <sub>IL</sub>	V <sub>IH</sub>	20H	0	0	1	0	0	0	0	0
Sector protection	Sector Address			V <sub>IH</sub>	V <sub>IL</sub>	01H*	0	0	0	0	0	0	0	1

\* Outputs 01H at protected sector address. Outputs 00H at unprotected sector address.

To activate this mode the programming equipment must force  $V_{ID}$  (11.5 to 12.5V) on address A<sub>9</sub>. Two identifier bytes may then be sequenced from the device outputs by toggling A<sub>0</sub> from V<sub>IL</sub> to V<sub>IH</sub>. All addresses are don't care apart from A<sub>1</sub> & A<sub>0</sub>. All identifiers for manufacturer and device will exhibit odd parity with D<sub>7</sub> defined as the parity bit.

The manufacturer and device codes may also be read via the command register, for instances when the MFM8126 is erased or programmed in a system without access to high voltage on A<sub>9</sub>. All identifiers for manufacturers and device will exhibit odd parity with the MSB(D<sub>7</sub>) defined as the parity bit. In order to read the proper device codes when executing the Autoselect, A<sub>1</sub> must be V<sub>IL</sub>.

## Write

Device erasure and programming are accomplished via the command register. The contents of the register serve as inputs to the internal state machine. The state machine outputs dictate the function of the device. The register is a latch used to store the commands along with the address and data information required to execute the command. The command register is written by bringing  $\overline{WE}$  to V<sub>IL</sub> while  $\overline{CS}$  is at V<sub>IL</sub> and  $\overline{OE}$  is at V<sub>IH</sub>. Addresses are latched on the falling edge of  $\overline{WE}$  while data is latched on the rising edge.

## Sector Protection

The MFM8126 features hardware sector protection. This feature will disable both program and erase operations in any number of sectors (0 through 7). The sector protect feature is enabled using programming equipment at the users site. The device is shipped with all sectors unprotected.

To activate this mode, the programming equipment must force  $V_{ID}$  on address pin  $A_9$  and control pin  $\overline{OE}$ . The sector addresses ( $A_{16}$ ,  $A_{15}$  and  $A_{14}$ ) should be set to the sector to be protected. Programming of the protection circuitry begins on the falling edge of the  $\overline{WE}$  pulse and is terminated with the rising edge of the same. Sector addresses must be held constant during the  $\overline{WE}$  pulse. (See Sector Address Table). To verify programming of the protection equipment circuitry, the programming equipment must force  $V_{ID}$  on address pin  $A_9$  with  $\overline{CS}$  and  $\overline{OE}$  at  $V_{IL}$  and  $\overline{WE}$  at  $V_{IH}$ . Reading the device at a particular sector address ( $A_{16}$ ,  $A_{15}$  and  $A_{14}$ ) will produce 01H at data outputs ( $D_0$ - $D_7$ ) for a protected sector. Otherwise the device will read 00H for unprotected sector. In this mode, the lower order addresses, except for  $A_0$  and  $A_1$ , are don't care. Address location 02H is reserved to verify sector protection of the device. Address pin  $A_1$  must be held at  $V_{IH}$  and  $A_0$  at  $V_{IL}$ . Address location 00H and 01H are reserved for autoselect codes. If a verify of the sector protection circuitry were done at these addresses, the device would output the manufacturer and device codes respectively.

It is also possible to determine if a sector is protected in the system by writing the autoselect command. Performing a read operation at particular sector addresses ( $A_{16}$ ,  $A_{15}$  and  $A_{14}$ ) and with  $A_1=V_{IH}$  and  $A_0=V_{IL}$  (other addresses are a don't care) will produce 01H data if those sectors are protected. Otherwise the device will read 00H for an unprotected sector. (See Sector Protect/Unprotect Algorithms for more details.)

## Sector Adresses Table.

	$A_{16}$	$A_{15}$	$A_{14}$	Address Range
SA0	0	0	0	0000H-3FFFFH
SA1	0	0	1	04000H-07FFFFH
SA2	0	1	0	08000H-0BFFFFH
SA3	0	1	1	0C000H-0FFFFH
SA4	1	0	0	10000H-13FFFFH
SA5	1	0	1	14000H-17FFFFH
SA6	1	1	0	18000H-1BFFFFH
SA7	1	1	1	1C000H-1FFFFH

## Auto Select Command

Flash memories are intended for use in applications where the local CPU alters memory contents. As such, manufacture and device codes must be accessible while the device resides in the target systems. PROM programmers typically access the signature codes by raising  $A_9$  to a high voltage. However, multiplexing high voltage onto the address lines is not generally a desired system design practice.

The device contains an autoselect operation to supplement traditional PROM programming methodology. The operation is initiated by writing the autoselect command sequence into the command register. Following the command write, a read cycle from address XXX0H retrieves the manufacture code of 01H. A read cycle from address XXX1H returns the device code 20H. A read cycle from address XXX2H returns information as to which sectors are protected. All manufacturer and device codes will exhibit odd parity with the MSB ( $D_7$ ) defined as the parity bit.

To terminate the operation, it is necessary to write the read/reset command sequence into the register.

## Byte Programming

The device is programmed on a byte-by-byte basis. Programming is a four bus cycle operation. There are two "unlock" write cycle. These are followed by the program set-up command and data write cycles. The addresses are latched on the falling edge of  $\overline{CS}$  or  $\overline{WE}$  (whichever last), the data is latched on the rising edge of  $\overline{CS}$  or  $\overline{WE}$  (whichever first), and then programming begins. Upon executing the Embedded Program Algorithm Command sequence the system is not required to provide further controls or timings. The device will automatically provide adequate internally generated program pulses and verify the programmed cell margin. The automatic programming operation is completed when the data on  $D_7$  is equivalent to data written to this bit (see write Operations Status) at which time the device returns to read mode and addresses are no longer latched. Data Polling must be performed at the memory location which is being programmed.

Programming is allowed in any address sequence and across sector boundaries. Beware that data "0" cannot be programmed back to a "1". Attempting to do so will hang up the device, or result in an apparent success according to the data polling algorithm. However, a read from Read/Reset Mode will show data is still "0". **Only an erase operation can convert "0"s to "1"s.**

## Chip Erase

Chip erase is a six bus cycle operation. There are two "unlock" write cycles. These are followed by writing the "set-up" command. Two more "unlock" write cycles are then followed by the chip erase command.

Chip erase doesn't require the user to program the device prior to erase. Upon executing the Embedded Erase Algorithm command sequence the device automatically will program and verify the entire memory for an all zero data pattern prior to electrical erase. The systems is not required to provide any controls or timings during these operations.

The automatic erase begins on the rising edge of the last  $\overline{WE}$  pulse in the command sequence and terminates when the data on  $D_7$  is "1" (See Written Operation Section) at which time the device returns to read the mode.

## Sector Erase

Sector erase is a six bus cycle operation. There are two "unlock" write cycles. These are followed by writing the "Set-up" command. Two more "unlock" write cycles are then followed by the sector erase command. The sector address (any address location within the desired sector) is latched on the falling edge of  $\overline{WE}$ , while the command (data) is latched on the rising edge of  $\overline{WE}$ . A time-out of 80 $\mu$ s from the rising edge of the last sector erase command will initiate the sector erase command(s).

Multiple sectors may be erased concurrently by writing the six bus cycle operations as described above. This sequence is followed with writes of the sector erase command (30H) to addresses in other sectors required to be concurrently erased. The time between writes must be less than 80 $\mu$ s, otherwise that command will not be accepted. It is recommended that processor interrupts be disabled during this time to guarantee this condition.

The interrupts can be re-enabled after the last Sector Erase command(s). If another falling edge of  $\overline{WE}$  occurs within the 80 $\mu$ s time-out window, the timer is reset. ( $D_3$  indicates if the timer window is still open). Loading the sector erase buffer may be done in any sequence and with any number of sectors (0 to 7). Any command other than Sector Erase during this period will reset the device to read mode, ignoring the previous.

Sector erase doesn't require the user to program the device prior to erase. The device automatically programs all memory locations in the sector(s) to be erased prior to electrical erase. When erasing a sector or sectors the remaining unselected sectors are not affected. The system is not required to provide any controls or timings during these operations.

The automatic sector erase begins after the 100 $\mu$ s time-out from the rising edge of the  $\overline{WE}$  pulse for the last sector erase command pulse and terminates when the data on  $D_7$  is "1" ( see Write Operation Status Section) at which time the device returns to read mode. Data polling must be performed at an address within any of the sectors being erased.

## Write Operations Status

### Hardware Sequence Flags

	STATUS	$D_7$	$D_6$	$D_5$	$D_3$	$D_2-D_0$
In Progress	Auto-Programming	$\overline{D_7}$	Toggle	0	0	Reserved for future use
	Programming in auto erase	0	Toggle	0	1	
	Erasing in Auto Erase	0	Toggle	0	1	
Exceeded Time limits	Auto-Programming	$\overline{D_7}$	Toggle	1	0	Reserved for future use
	Programming in auto erase	0	Toggle	1	1	
	Erasing in Auto-Erase	0	Toggle	1	1	

## Data Polling - $D_7$

The MFM8126 features Data Polling as a method to indicate to the host system that the Embedded Algorithms are in progress or completed.

During the Embedded Programming Algorithm, an attempt to read the device will produce complement data of the data last written to  $D_7$ . Upon completion of the Embedded Programming Algorithm an attempt to read the device will produce the true data last written to  $D_7$ . Data Polling is valid after the rising edge of the forth  $\overline{WE}$  pulse in the four write pulse sequence.

During the Embedded Erase Algorithm,  $D_7$  will be "0" until the erase operation is completed. Upon completion data at  $D_7$  is "1". For chip erase, the Data Polling is valid after the rising edge of the sixth  $\overline{WE}$  pulse in the six write pulse sequence. For sector erase, Data Polling is valid after the last rising edge of the sector erase  $\overline{WE}$  pulse.

The Data Polling feature is only active during the Embedded Programming Algorithm, Embedded Erase Algorithm, or sector erase time-out.

### Toggle Bit - D<sub>6</sub>

The MFM8126 also features the "toggle bit" as a method to indicate to the host system that the Embedded Algorithms are in progress or completed.

During an Embedded Program or Erase Algorithm cycle, successive attempts to read ( $\overline{\text{OE}}$  Toggling) data from the device will result in D<sub>6</sub> toggling between one and zero. Once the Embedded Program or Erase Algorithm cycle is completed, D<sub>6</sub> will stop toggling and valid data will be read on successive attempts. During programming, the Toggle bit is valid after the rising edge of the fourth WE pulse in the four write pulse sequence. For chip erase, the Toggle bit is valid after the sixth WE pulse in the six write pulse sequence.

For sector erase, the Toggle bit is valid after the last rising edge of the sector erase WE pulse. The Toggle Bit is active during the sector time-out. Note:  $\overline{\text{CS}}$  or  $\overline{\text{OE}}$  toggling will toggle D<sub>6</sub>.

### Exceeding Time Limits - D<sub>5</sub>

D<sub>5</sub> will indicate if the program or erase time has exceeded the specified limits. Under these conditions D<sub>5</sub> will produce "1", indicating the program or erase cycle was not successfully completed. Data Polling is the only operating function of the device under this condition. The  $\overline{\text{CS}}$  circuit will partially power down the device under these conditions (to approximately 2mA). The OE and WE pins will control the output disable functions. To reset the device, write reset command sequence to the device. This allows the system to continue to use the other active sectors in the device.

If this failure condition occurs during the sector erase operation, it specifies that a particular sector is bad and it may not be reused. However, other sectors are still functional and may be used for additional program or erase operations. The device must be reset to use other sectors. Write the Reset command sequence to the device, and then execute the program or erase command sequence.

If this failure condition occurs during the chip erase operation, it specifies that the entire chip is bad or combination of sectors are bad.

If this failure condition occurs during the byte programming operation, it specifies that the entire sector containing that byte is bad and this sector may not be reused (other sectors are still functional and can be reused). The device must be reset to use other sectors.

The D<sub>5</sub> failure condition may also appear if a user tries to program a non blank location without erasing. In this case the system never reads valid data on the D<sub>7</sub> bit and D<sub>6</sub> never stops toggling. Once the device has exceeded timing limits, the D<sub>5</sub> bit will indicate a "1". Please note that this is not a device failure condition since the device was incorrectly used. The device must be reset to continue using the device.

### Hardware Sequence Flag - D<sub>4</sub>

If the device has exceeded the specified erase or program time and D<sub>5</sub> is "1", then D<sub>4</sub> will indicate at which step in the algorithm the device exceeded the limits. A "0" in D<sub>4</sub> indicates in programming, a "1" indicates an erase.

### Sector Erase Timer - D<sub>3</sub>

After the completion of the initial sector erase command sequence the sector erase time-out will begin. D<sub>3</sub> will remain low until the time-out is complete. Data Polling and Toggle Bit are valid after the initial sector erase command sequence.

If  $\overline{\text{Data}}$  Polling or the Toggle Bit indicates the device has been written with a valid erase command,  $D_3$  may be used to determine if the sector erase timer window is still open. If  $D_3$  is high the internally controlled erase cycle has begun; attempts to write subsequent commands to the device will be ignored until the erase operation is completed as indicated by  $\overline{\text{Data}}$  Polling or Toggle Bit. If  $D_3$  is low, the device will accept additional sector erase commands. To insure the command has been accepted, the software should check the status of  $D_3$  prior to and following each subsequent sector erase command. If  $D_3$  were high on the second status check, the command may not have been accepted.

### Data Protection

The MFM8126 is designed to offer protection against accidental erasure or programming caused by spurious system level signals that may exist during power transition. During power up the device automatically resets the internal state machine in the Read mode. Also, with its controls register architecture, alteration of the memory contents only occurs after successful completion of specific multi-bus cycle command sequences. The device also incorporates several features to prevent inadvertent write cycles resulting from  $V_{CC}$  power up and power down transitions or system noise.

### Low $V_{CC}$ Write Inhibit

To avoid initiation of a write cycle during  $V_{CC}$  power up and power down, a write cycle is locked out for  $V_{CC}$  less than 3.2V (typically 3.7V). If  $V_{CC} < V_{LKO}$ , the command register is disabled and all internal program/erase circuits are disabled. Under this condition the device will reset to read mode. Subsequent writes will be ignored until the  $V_{CC}$  level is greater than  $V_{LKO}$ . It is usually correct to prevent unintentional writes when  $V_{CC}$  is above 3.2V.

### Write Pulse "Glitch" Protection

Noise pulses of less than 5ns (typical) on  $\overline{\text{OE}}$ ,  $\overline{\text{CS}}$ ,  $\overline{\text{WE}}$  will not initiate a write cycle

### Logical Inhibit

Writing is inhibited by holding any one of  $\overline{\text{OE}}=V_{IL}$ ,  $\overline{\text{CS}}=V_{IH}$  or  $\overline{\text{WE}}=V_{IH}$ . To initiate a write cycle  $\overline{\text{CS}}$  and  $\overline{\text{WE}}$  must be logical zero while  $\overline{\text{OE}}$  is a logical one.

### Power-Up Write Inhibit

Power-up of the device with  $\overline{\text{WE}}=\overline{\text{CS}}=V_{IL}$  and  $\overline{\text{OE}}=V_{IH}$  will not accept commands on the rising edge of  $\overline{\text{WE}}$ . The internal state machine is automatically reset to the read mode on power-up.

### Sector Protect

Sectors of the MFM8126 may be hardware protected at the users factory. The protection circuitry will disable both program and erase functions for the protected sector(s). Requests to program or erase a protected sector will be ignored by the device.

**Embedded Programming Algorithm**

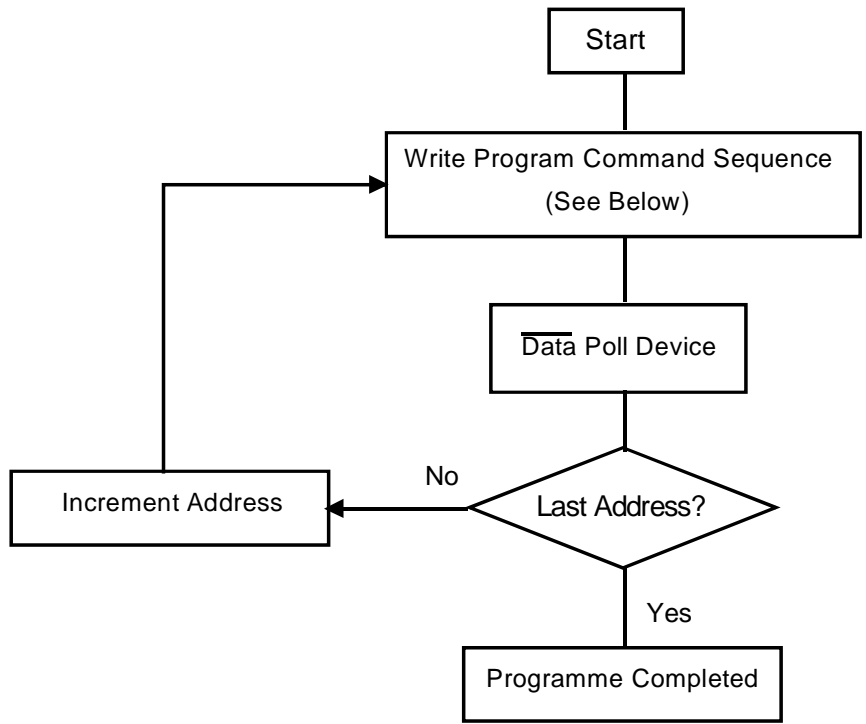

Program Command Sequence (Address/Command)

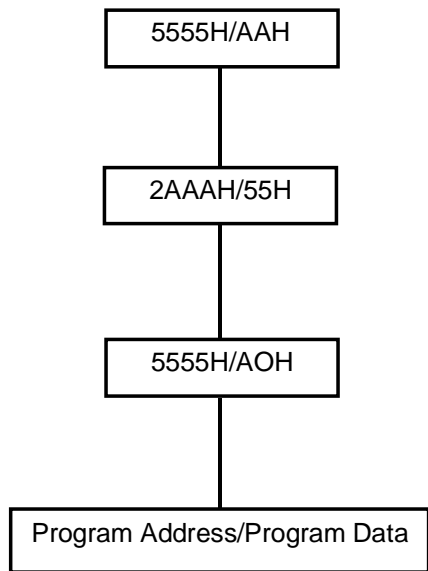

**Embedded Erase Algorithm**

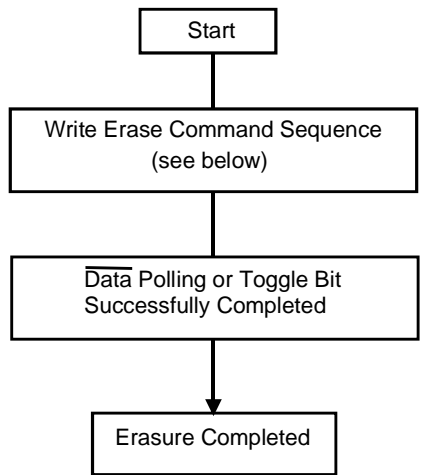

Chip Erase Command Sequence  
(Address/Command):

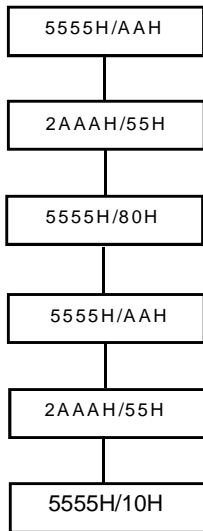

Individual Sector/Multiple Sector  
Erase Command Sequence  
(Address/Command)

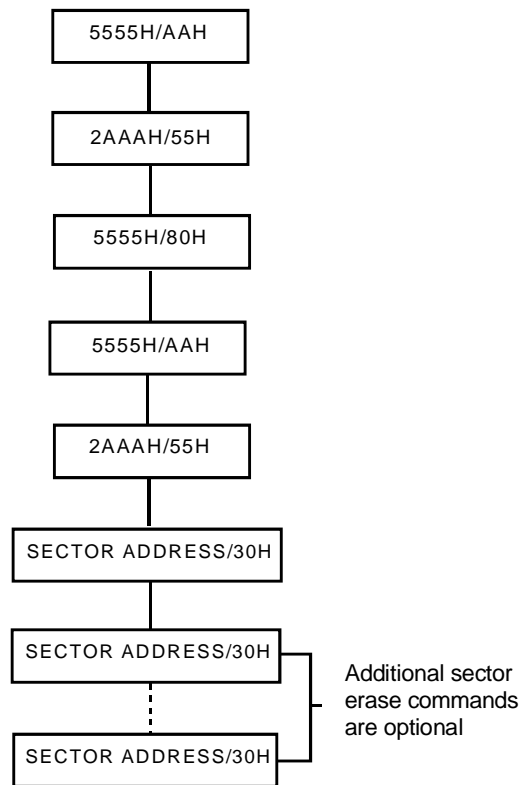

**Data Polling Algorithm**

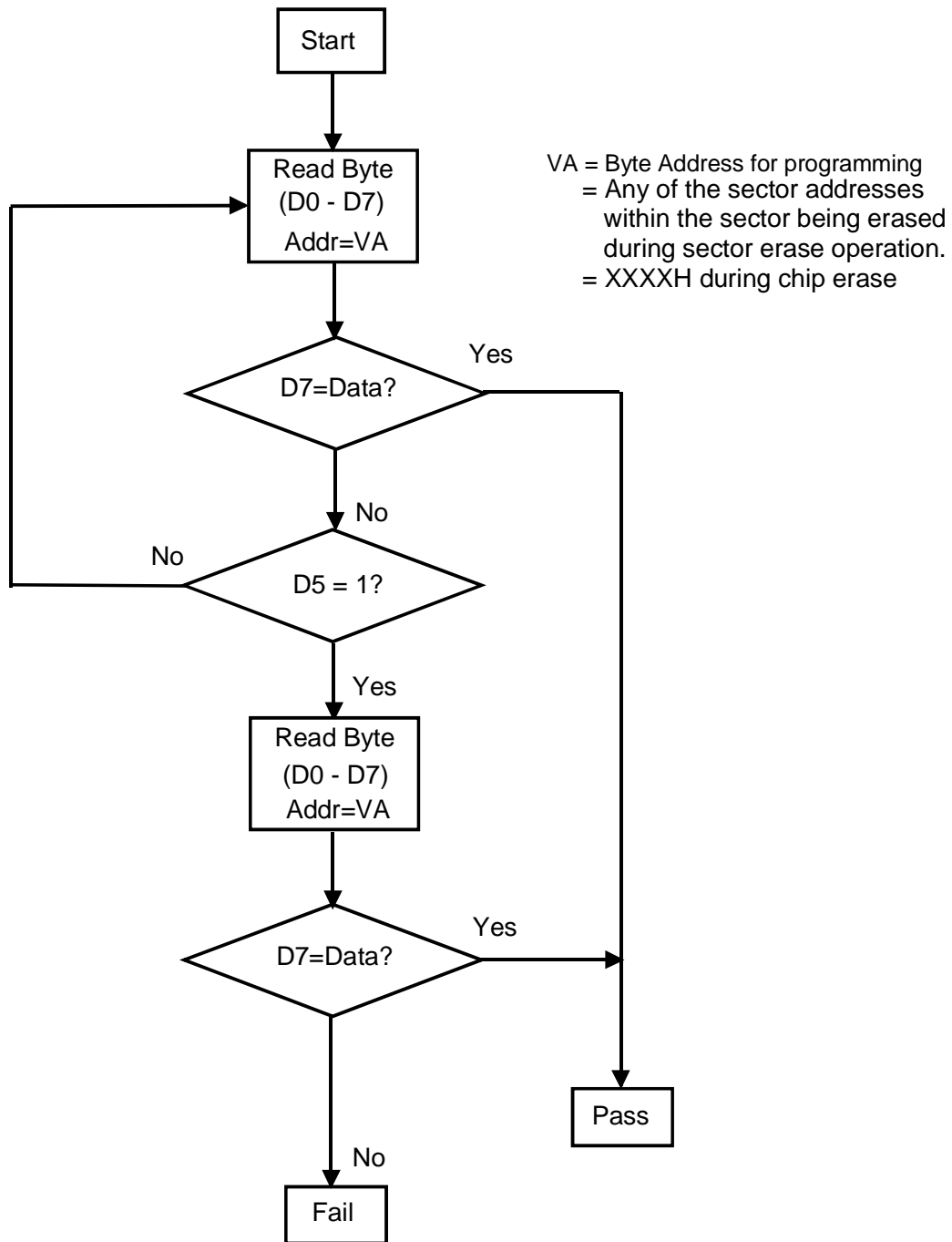

Note : D7 is rechecked even if D5 = "1" because D7 may change simultaneously with D5.

## Toggle Bit Algorithm

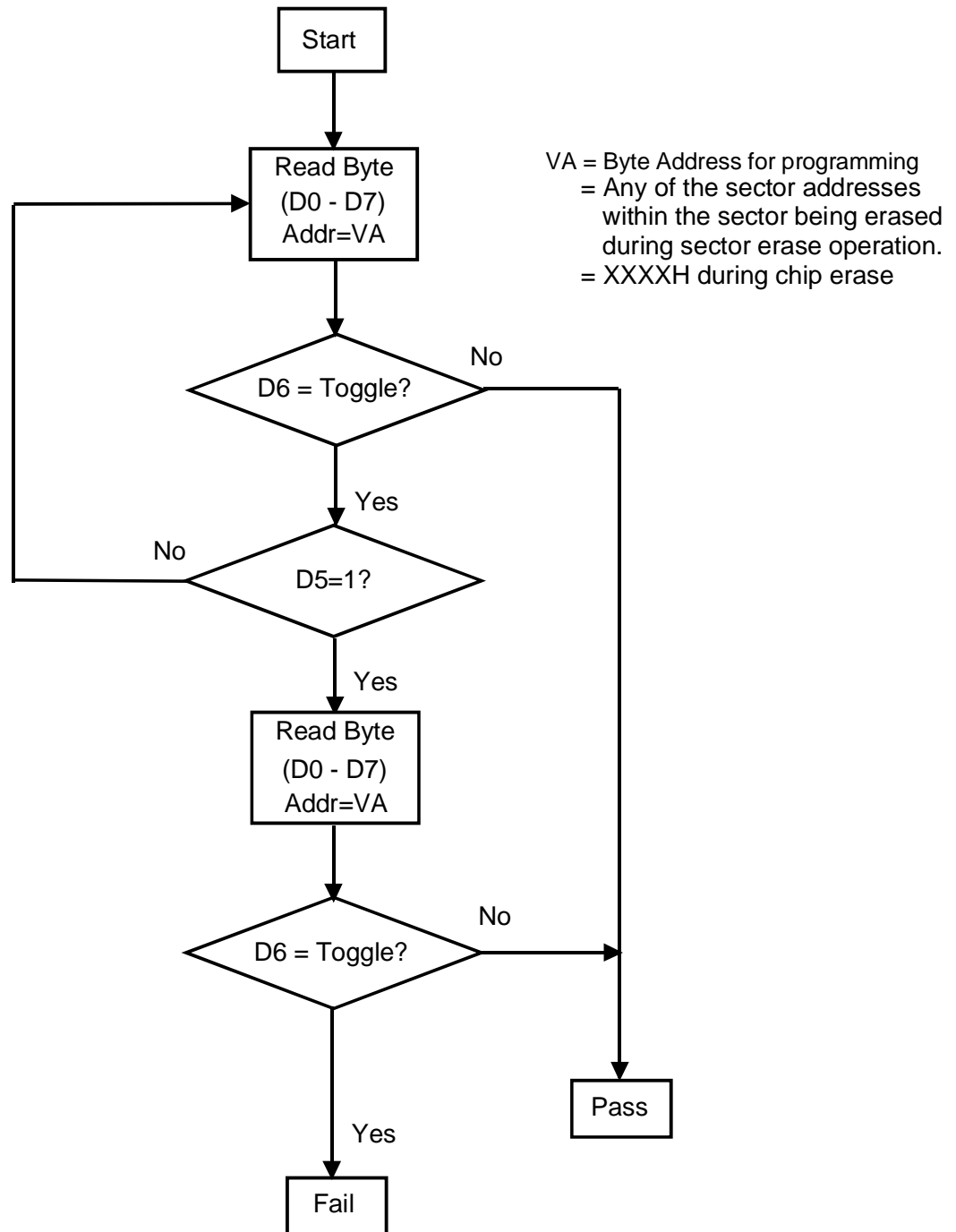

Note : D6 is rechecked even if D5 = "1" because D6 may stop toggling at the same time as D5 changing to "1"

**Sector Unprotect Algorithm**

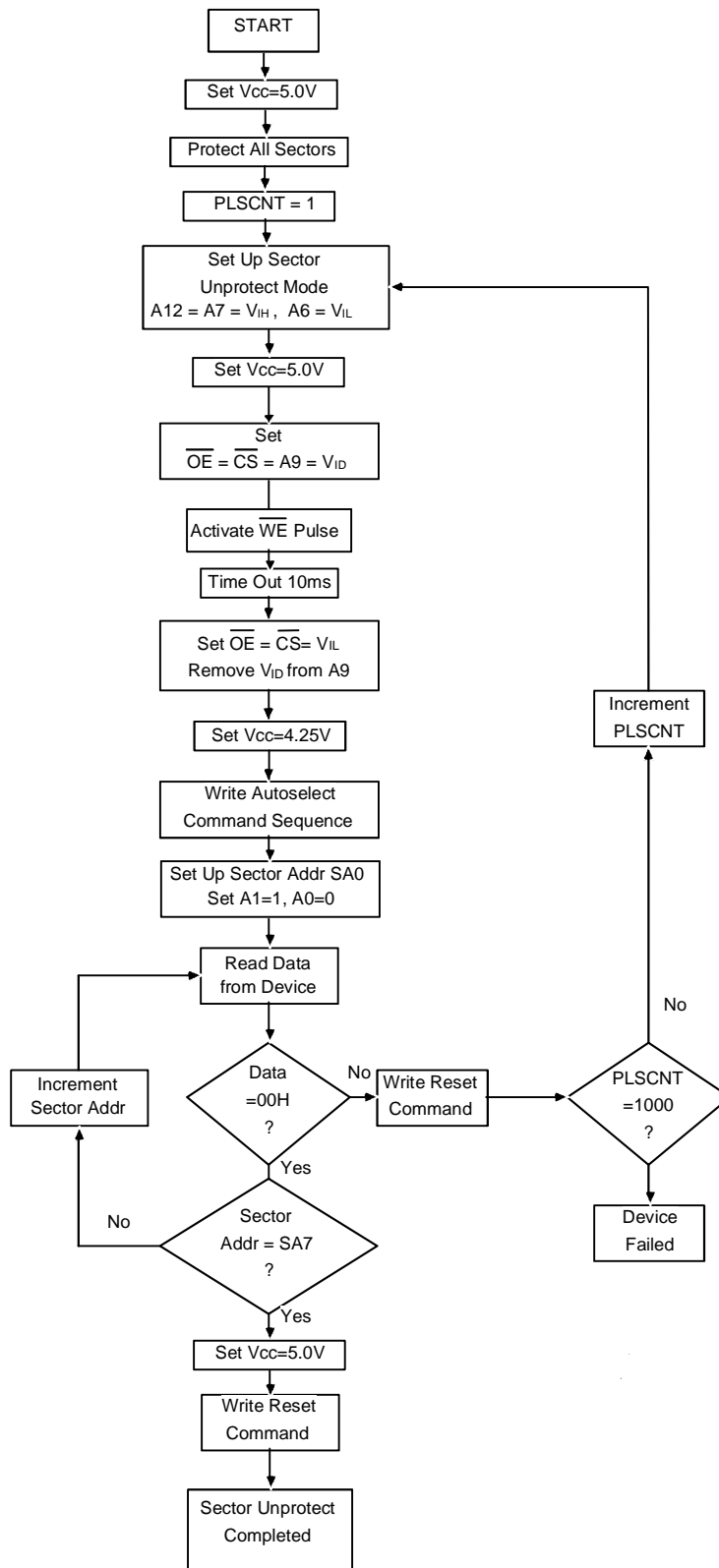

**NOTES:**

SA0 = Sector Addr for initial sector

SA7 = Sector Addr to last sector

**Sector Protection Algorithm**

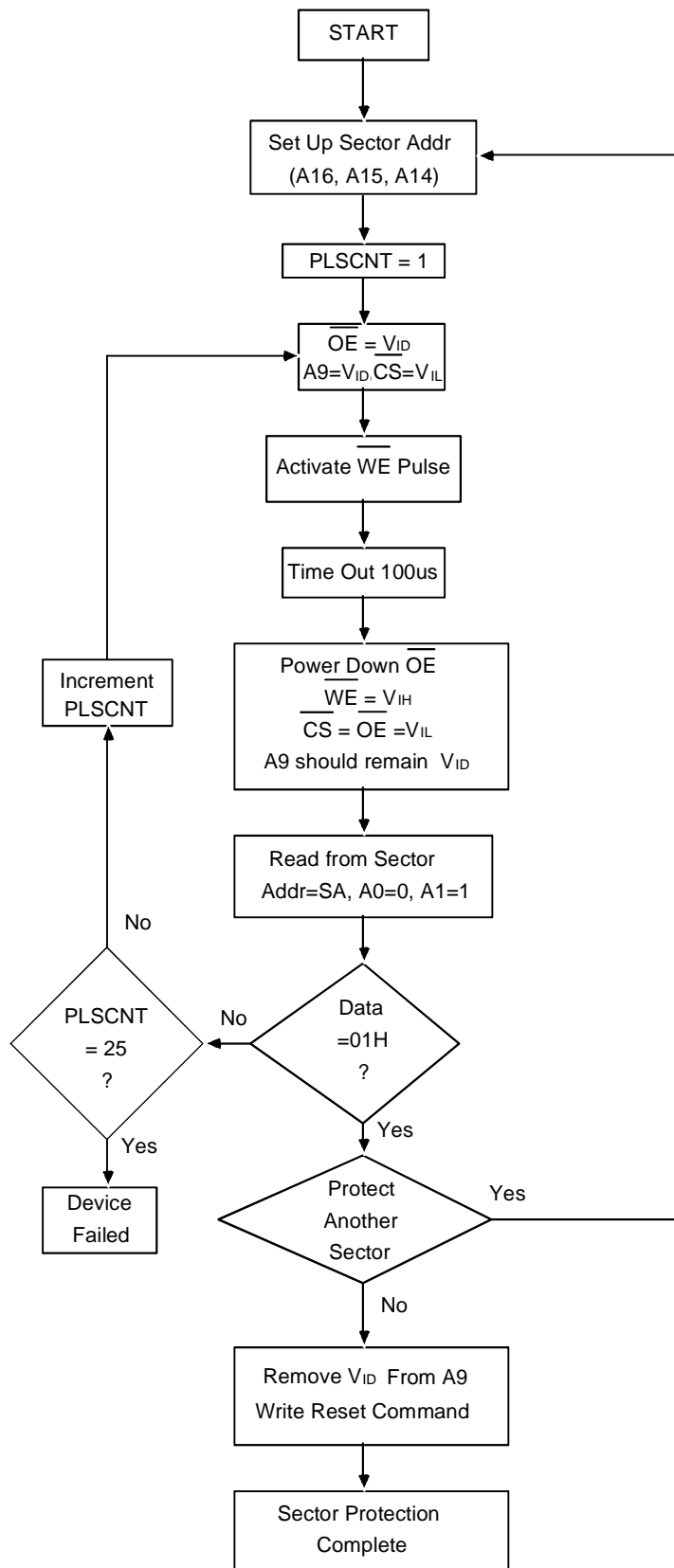



**Screening****Military Screening Procedure**

**Component Screening Flow** for high reliability product using methods from 5004.

**MB COMPONENT SCREENING FLOW**

<i>SCREEN</i>	<i>TEST METHOD</i>	<i>LEVEL</i>
<b>Mechanical</b>		
Temperature cycle	1010 Condition C (10 Cycles, -65°C to +150°C)	100%
Constant acceleration	2001 Condition D (Y, only) (20,000g)	100%
Pre-Burn-in electrical	Per applicable device specifications at $T_A=+25^\circ\text{C}$	100%
Burn-in	Method 1015, Condition D, $T_A=+125^\circ\text{C}$ , 160hrs min	100%
<b>Endurance</b>	As per internal specification	
Write Cycle endurance and Data Retention performance		
<b>Final Electrical Tests</b>	Per applicable Device Specification	
Static (dc)	a) @ $T_A=+25^\circ\text{C}$ and power supply extremes b) @ temperature and power supply extremes	100% 100%
Functional	a) @ $T_A=+25^\circ\text{C}$ and power supply extremes b) @ temperature and power supply extremes	100% 100%
Switching (ac)	a) @ $T_A=+25^\circ\text{C}$ and power supply extremes b) @ temperature and power supply extremes	100% 100%
<b>Percent Defective allowable (PDA)</b>	Calculated at post-burn-in at $T_A=+25^\circ\text{C}$	5%
<b>Hermeticity</b>	1014	
Fine	Condition A	100%
Gross	Condition C	100%
<b>External Visual</b>	2009 Per vendor or customer specification	100%

## Ordering Information

### MFM8126VMB - 90E

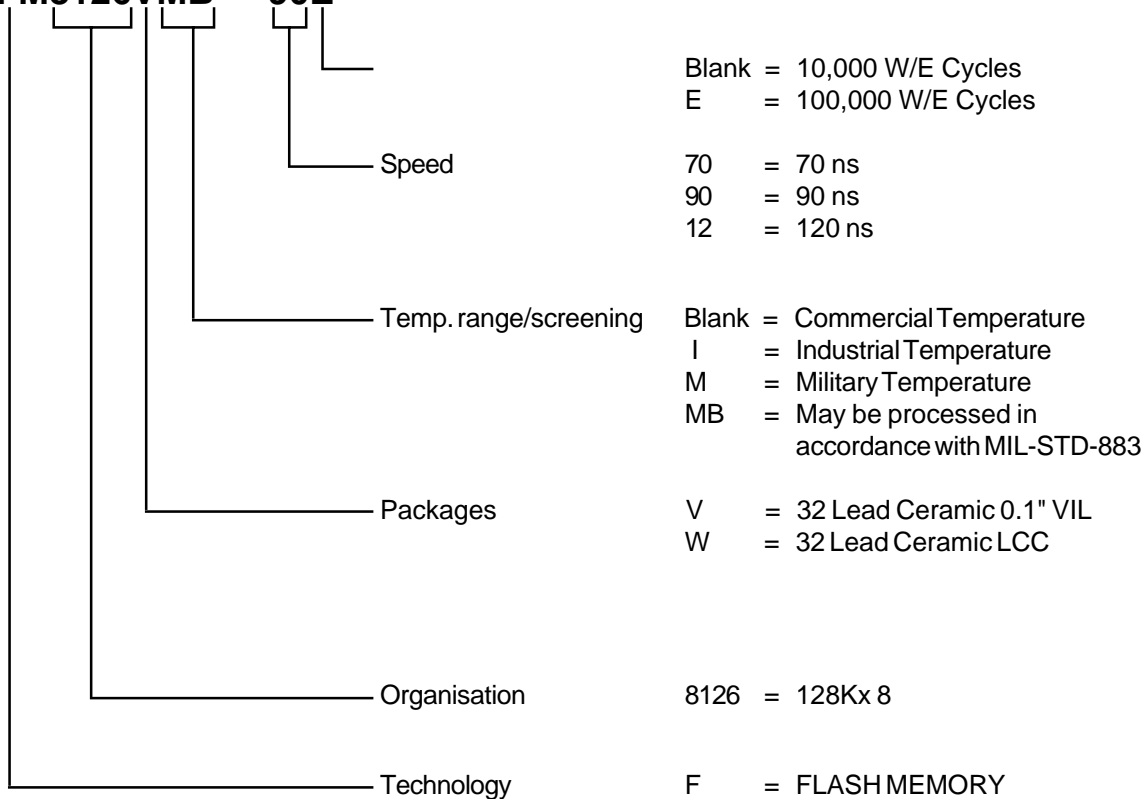

**THE ABOVE PARTS ARE NOT RECOMMENDED FOR NEW DESIGNS AND MAY BE MADE OBSOLETE WITHOUT NOTICE....**

**Note :**

Although this data is believed to be accurate, the information contained herein is not intended to and does not create any warranty of merchantibility or fitness for a particular purpose.

Our products are subject to a constant process of development. Data may be changed at any time without notice.

Products are not authorised for use as critical components in life support devices without the express written approval of a company director.