



**512K x 32 FLASH MODULE**

**PUMA 68F16006/A-70/90/12/15**

Issue 4.4 : May 2001

Elm Road, West Chirton, NORTH SHIELDS, Tyne & Wear  
NE29 8SE, England Tel. +44 (0)191 2930500 Fax. +44 (0) 191 2590997

**Description**

The PUMA 68F16006 is a high density 16Mbit CMOS 5V Only FLASH memory module in a JEDEC 68 pin surface mount PLCC, with read access times of 70, 90, 120, and 150ns. The plastic device is screened to ensure high reliability. The output width is user configurable as 8, 16 or 32 bits using four Chip Selects (CE1~4) for optimum application flexibility. The module incorporates Embedded Algorithms for Program and Erase with Sector architecture (64K sector) and supports full chip erase.

**Features**

- Fast Access Times of 70/90/120/150 ns.
- Output Configurable as 32 / 16 / 8 bit wide.
- Industrial, Military or Military (High Rel) grade.
- Automatic Write/Erase by Embedded Algorithm - end of Write/Erase indicated by DATA Polling and Toggle Bit.
- Flexible Sector Erase Architecture - 64K byte sector size, with hardware protection of any number of sectors.
- Single Byte Program of 16µs (Min.), Sector Program time of 1 sec (typ.)
- Erase/Write Cycle Endurance 100,000 (Min.) - E variant.

**Block Diagram (see page 24 for 'A' version)**

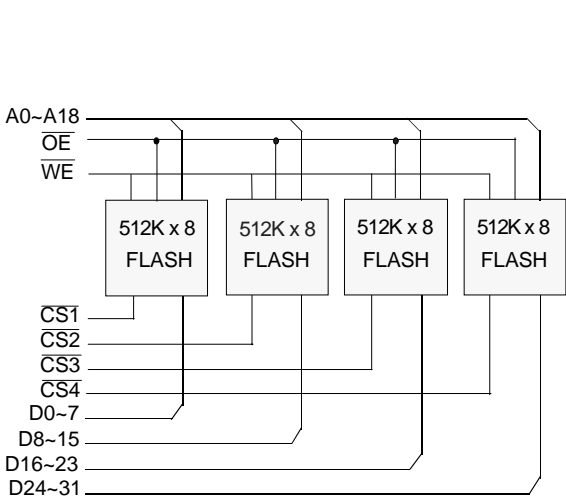

**Pin Definition (see page 24 for 'A' version)**

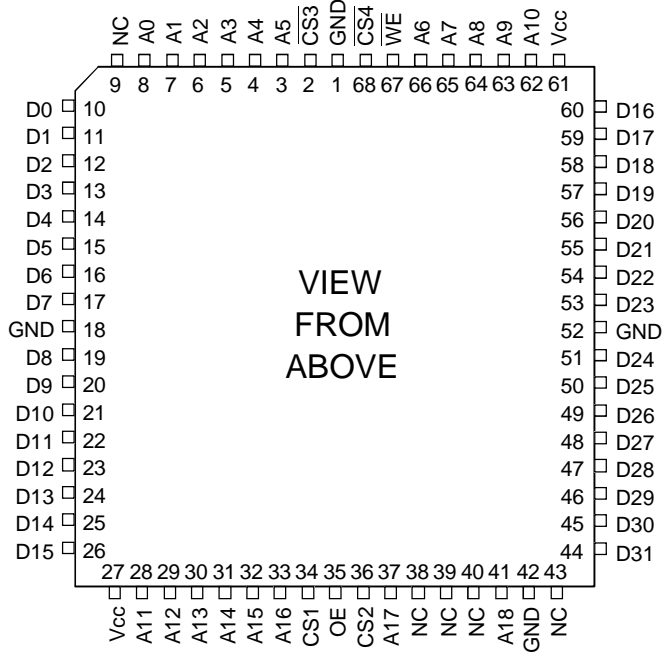

**Pin Functions**

<b>A0-A18</b>	<b>Address Input</b>	<b>D0-D31</b>	<b>Data Inputs/Outputs</b>
<b>CE1-4</b>	<b>Chip Enables</b>	<b>WE</b>	<b>Write Enable (WE1-4 for 'A' version)</b>
<b>OE</b>	<b>Output Enable</b>	<b>Vcc</b>	<b>Power (+5V)</b>
<b>GND</b>	<b>Ground</b>		

**Absolute Maximum Ratings** <sup>(1)</sup>

	<i>max</i>	<i>unit</i>
Voltage on any pin w.r.t. Gnd	-2.0 to +7	V
Supply Voltage <sup>(2)</sup>	-2.0 to +7	V
Voltage on A9 w.r.t. Gnd <sup>(3)</sup>	-2.0 to +14	V
Storage Temperature	-65 to +150	°C

- Notes : (1) Stresses above those listed may cause permanent damage to the device. This is a stress rating only and functional operation of the device at those or any other conditions above those indicated in the operational sections of this specification is not implied.
- (2) Minimum DC voltage on any input or I/O pin is -0.5V. Maximum DC voltage on output and I/O pins is  $V_{CC}+0.5V$ . During transitions voltage may overshoot by +/-2V for upto 20ns
- (3) Minimum DC input voltage on A9 is -0.5V during voltage transitions, A9 may overshoot  $V_{SS}$  to -2V for periods of up to 20ns, maximum DC input voltage in A9 is 13.5V which may overshoot to 14.0V for periods up to 20ns

**Recommended Operating Conditions**

<i>Parameter</i>		<i>min</i>	<i>typ</i>	<i>max</i>	<i>unit</i>
Supply Voltage	$V_{CC}$	4.5	5.0	5.5	V
Input High Voltage	$V_{IH}$	2.0	-	$V_{CC}+0.5$	V
Input Low Voltage	$V_{IL}$	$0.7V_{CC}$	-	$V_{CC}+0.3$	V
Operating Temperature	$T_A$	0	-	70	°C
	$T_{AI}$	-40	-	85	°C (-I suffix)
	$T_{AM}$	-55	-	125	°C (-M\MB suffix)

<i>Parameter</i>	<i>Symbol</i>	<i>Test Condition</i>	<i>min</i>	<i>typ</i>	<i>max</i>	<i>Unit</i>
I/P Leakage Current Address, OE	$I_{LI1}$	$V_{CC}=V_{CC}$ max, $V_{IN}=0V$ or $V_{CC}$	-	-	±4	µA
A9 Input Leakage Current	$I_{LI1}$	$V_{CC}=V_{CC}$ max, A9=12.5V	-	-	200	µA
Other Pins	$I_{LI2}$	$V_{CC}=V_{CC}$ max, $V_{IN}=0V$ or $V_{CC}$	-	-	±1	µA
Output Leakage Current	$I_{LO}$	$V_{CC}=V_{CC}$ max, $V_{OUT}=0V$ or $V_{CC}$	-	-	±4	µA
$V_{CC}$ Operating Current	32 bit $I_{CCO32}$	$\overline{CE}=V_{IL}^{(1)}$ , $\overline{OE}=V_{IH}$ , $I_{OUT}=0mA$ , $f=6MHz$	-	-	160	mA
	16 bit $I_{CCO16}$	As above	-	-	82	mA
	8 bit $I_{CCO8}$	As above	-	-	43	mA
$V_{CC}$ Program/Erase Current	32 bit $I_{CCP32}$	Programming in Progress	-	-	240	mA
	16 bit $I_{CCP16}$	As above	-	-	122	mA
	8 bit $I_{CCP8}$	As above	-	-	63	mA
Standby Supply Current	$I_{SB1}$	$V_{CC}=V_{CC}$ max, $\overline{CE}=V_{IH}^{(1)}$ $\overline{OE}=V_{IH}$	-	-	4	mA
Autoselect / Sector Protect Voltage	$V_{ID}$	$V_{CC} = 5.0V$	11.5	-	12.5	V
Voltage for Sector Unprotect	$V_{SP}$	$V_{CC} = 5.0V$	9.5	-	10.5	V
Output Low Voltage	$V_{OL}$	$I_{OL}=12mA$ . $V_{CC} = V_{CC}$ min.	-	-	0.45	V
Output High Voltage	$V_{OH1}$	$I_{OH}=-2.5mA$ . $V_{CC} = V_{CC}$ min.	2.4	-	-	V
Low $V_{CC}$ Lock-Out Voltage	$V_{LKO}$		3.2	-	4.2	V

- Notes (1)  $\overline{CE}$  above are accessed through  $\overline{CE1-4}$ . These inputs must be operated simultaneously for 32 bit operation, in pairs in 16 bit mode and singly for 8 bit mode.

**Capacitance** ( $T_A=25^\circ\text{C}, f=1\text{MHz}$ )

<i>Parameter</i>		<i>Symbol</i>	<i>Test Condition</i>	<i>typ</i>	<i>max</i>	<i>Unit</i>
Input Capacitance	Address, $\overline{\text{OE}}$	$C_{\text{IN1}}$	$V_{\text{IN}}=0\text{V}$	-	30	pF
	Other pins	$C_{\text{IN2}}$	$V_{\text{IN}}=0\text{V}$	-	36	pF
Output Capacitance	32 bit	$C_{\text{OUT32}}$	$V_{\text{OUT}}=0\text{V}$	-	48	pF

Note: These parameters are calculated, not measured.

**AC Test Conditions**

- \* Input pulse levels : 0.0V to 3.0V
- \* Input rise and fall times : 5 ns
- \* Input and output timing reference levels : 1.5V
- \* VCC = 5V +/- 10%
- \* Module tested in 32 bit mode

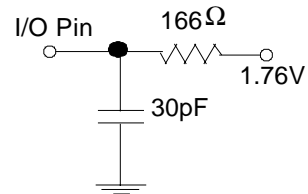

**AC OPERATING CONDITIONS****Read Cycle**

<i>Parameter</i>	<i>Symbol</i>	70			90			Unit
		min	typ	max	min	typ	max	
Read Cycle Time	tRC	70	-	-	90	-	-	ns
Address to output delay	tACC	-	-	70	-	-	90	ns
Chip enable to output	tCE	-	-	70	-	-	90	ns
Output enable to output	tOE	-	-	35	-	-	35	ns
Output enable to output High Z	tDF	-	-	20	-	-	20	ns
Output hold time from address $\overline{CE}$ or $\overline{OE}$ whichever occurs first	tOH	0	-	-	0	-	-	ns

<i>Parameter</i>	<i>Symbol</i>	120			150			Unit
		min	typ	max	min	typ	max	
Read Cycle Time	tRC	120	-	-	150	-	-	ns
Address to output delay	tACC	-	-	120	-	-	150	ns
Chip enable to output	tCE	-	-	120	-	-	150	ns
Output enable to output	tOE	-	-	50	-	-	55	ns
Output enable to output High Z	tDF	-	-	30	-	-	35	ns
Output hold time from address $\overline{CE}$ or $\overline{OE}$ whichever occurs first	tOH	0	-	-	0	-	-	ns

**Write/Erase/Program**

<i>Parameter</i>	<i>Symbol</i>	<i>min</i>	<i>typ</i>	<i>max</i>	<i>unit</i>
Write Cycle time <sup>(4)</sup>	$t_{WC}$	90	-	-	ns
Address Setup time	$t_{AS}$	0	-	-	ns
Address Hold time	$t_{AH}$	50	-	-	ns
Data Setup Time	$t_{DS}$	50	-	-	ns
Data hold Time	$t_{DH}$	0	-	-	ns
Output Enable Setup Time	$t_{OES}$	0	-	-	ns
Read Recover before Write	$t_{GHWL}$	0	-	-	ns
$\overline{CE}$ setup time	$t_{CE}$	0	-	-	ns
$\overline{CE}$ hold time	$t_{CH}$	0	-	-	ns
$\overline{WE}$ Pulse Width	$t_{WP}$	50	-	-	ns
$\overline{WE}$ Pulse Width High	$t_{WPH}$	20	-	-	ns
Programming operation	$t_{WHWH1}$	-	16	-	$\mu$ s
Sector Erase operation <sup>(1)</sup>	$t_{WHWH2}$	-	1	30	sec
Chip Erase operation <sup>(1)</sup>	$t_{WHWH2}$	-	8	-	sec
Vcc setup time <sup>(4)</sup>	$t_{VCS}$	50	-	-	$\mu$ s
Voltage Transition Time <sup>(2,4)</sup>	$t_{VLHT}$	4	-	-	$\mu$ s
Write Pulse Width 1 <sup>(2)</sup>	$t_{WPP1}$	100	-	-	$\mu$ s
Write Pulse Width 2 <sup>(2)</sup>	$t_{WPP2}$	10	-	-	ms
$\overline{OE}$ setup to $\overline{WE}$ active <sup>(2,4,5)</sup>	$t_{OESP}$	4	-	-	$\mu$ s
$\overline{CE}$ setup to $\overline{WE}$ active <sup>(3,4,5)</sup>	$t_{CSP}$	4	-	-	$\mu$ s

Notes: (1) This does not include the preprogramming time.

(2) These timings are for Sector Protect/Unprotect operations.

(3) This timing is only for Sector Unprotect.

(4) Not 100% tested.

(5)  $\overline{WE}$  refers to  $\overline{WE}1\sim4$  on the PUMA 67F16006A.

### Write/Erase/Program Alternate CE controlled Writes

Parameter	Symbol				Unit
		min	typ	max	
Write Cycle time <sup>(2)</sup>	$t_{WC}$	90	-	-	ns
Address Setup time	$t_{AS}$	0	-	-	ns
Address Hold time	$t_{AH}$	50	-	-	ns
Data Setup Time	$t_{DS}$	50	-	-	ns
Data hold Time	$t_{DH}$	0	-	-	ns
Output Enable Setup Time	$t_{OES}$	0	-	-	ns
Read Recover before Write	$t_{GHEL}$	0	-	-	ns
$\overline{WE}$ setup time <sup>(3)</sup>	$t_{WS}$	0	-	-	ns
$\overline{WE}$ hold time <sup>(3)</sup>	$t_{WH}$	0	-	-	ns
$\overline{CE}$ Pulse Width	$t_{CP}$	50	-	-	ns
$\overline{CE}$ Pulse Width High	$t_{CPH}$	120	-	-	ns
Programming operation	$t_{WHWH1}$	-	16	-	us
Sector Erase operation <sup>(1)</sup>	$t_{WHWH2}$	-	1	30	sec
Chip Erase operation <sup>(1)</sup>	$t_{WHWH2}$	-	8	-	sec
Vcc setup time <sup>(2)</sup>	$t_{VCE}$	-	50	-	us

Note: (1) Does not include pre-programming time.

(2) Not 100% tested.

(3)  $\overline{WE}$  refers to  $\overline{WE}1\sim4$  on the PUMA 67F16006A.

**AC Waveforms for Read Operation**

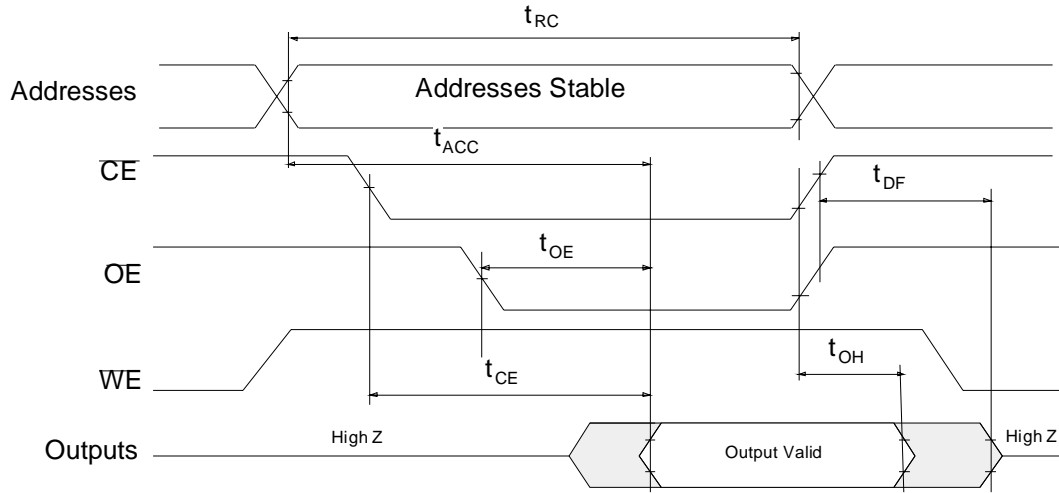

**AC Waveforms Program**

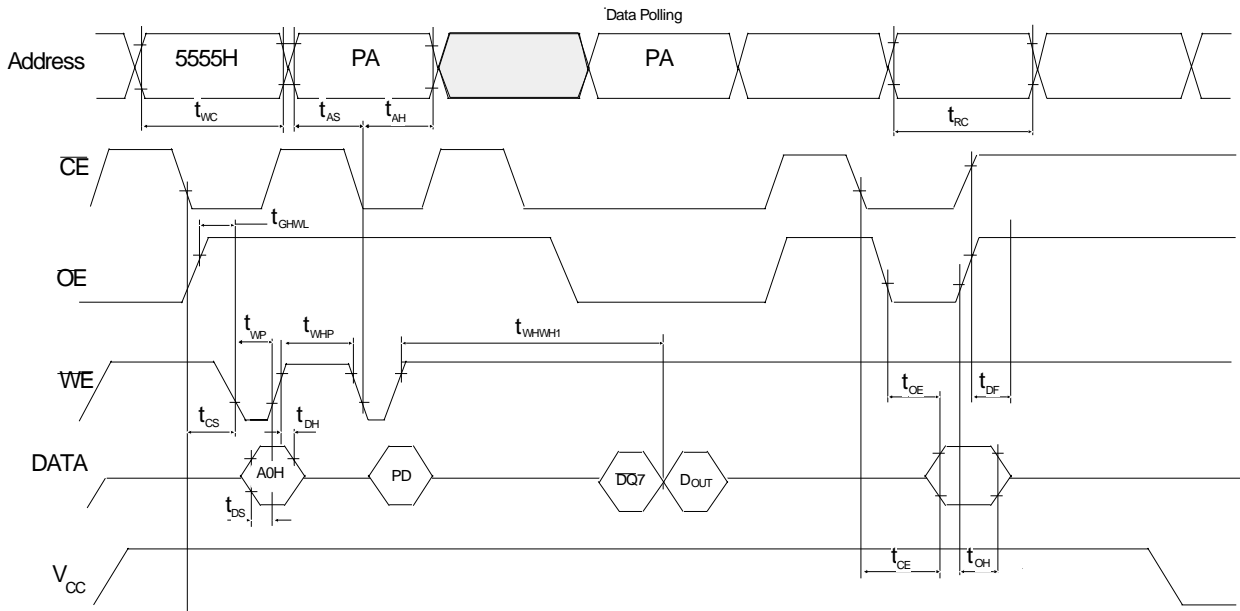

**Notes:**

1. PA is address of the memory location to be programmed.
2. PD is data to be programmed at byte address.
3. DQ7 is the out put of the complement of the data written to the device.
4. DOUT is the output of the data written to the device.
5. Figure indicates last two bus cycles of four bus cycle sequence.

**A.C Waveforms - Alternate CE controlled Program operation timings**

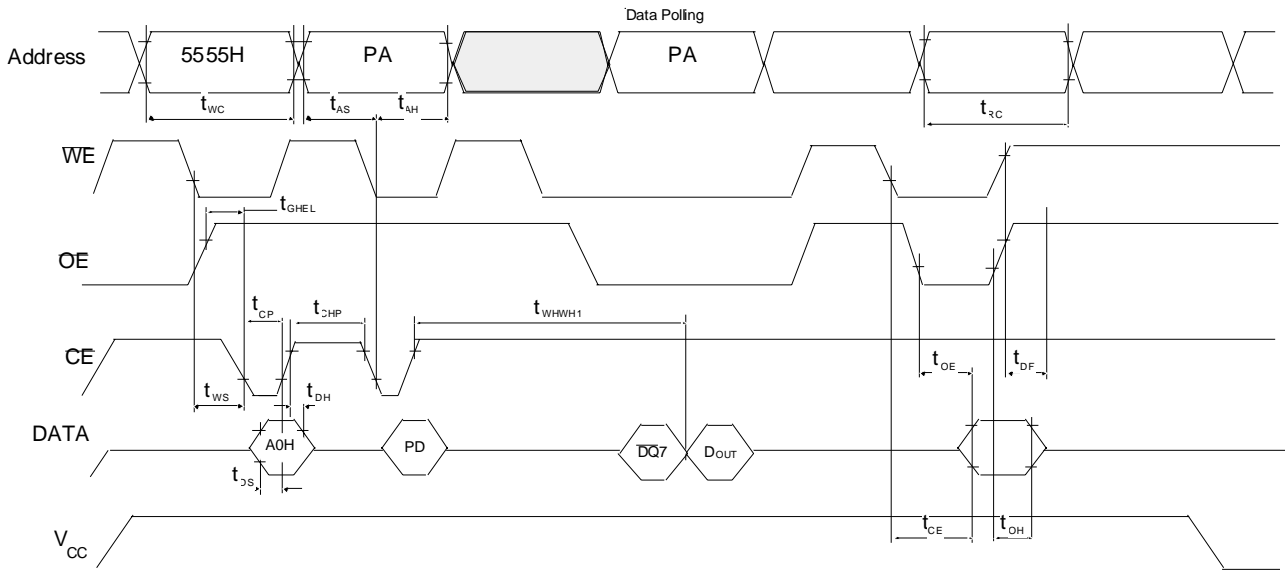

**NOTES:**

1. PA is address of memory location to be programmed.
2. PD is data to be programmed at byte address.
3. DQ7 is the output of the complement of the data written to the device.
4. DOUT is the output of the data written to the device.
5. Figure indicates last two bus cycles of four bus cycle sequence.

**AC Waveforms for Data Polling During Embedded Algorithm Operations**

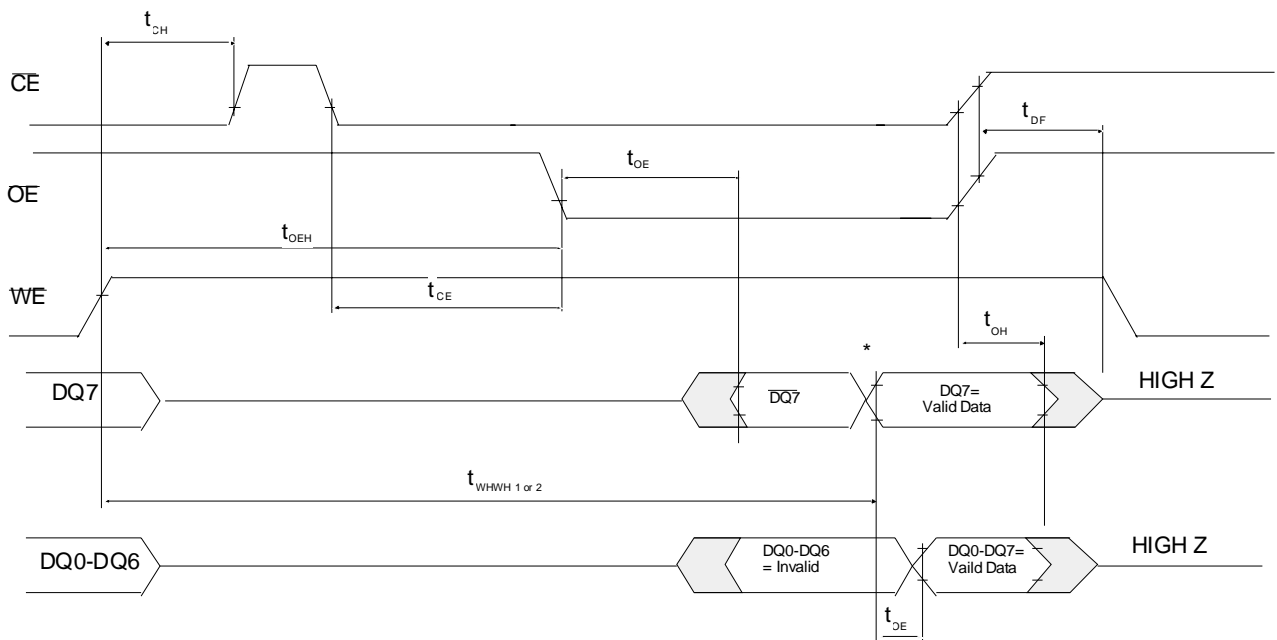

### AC Waveforms for Toggle Bit During Embedded Algorithm Operations

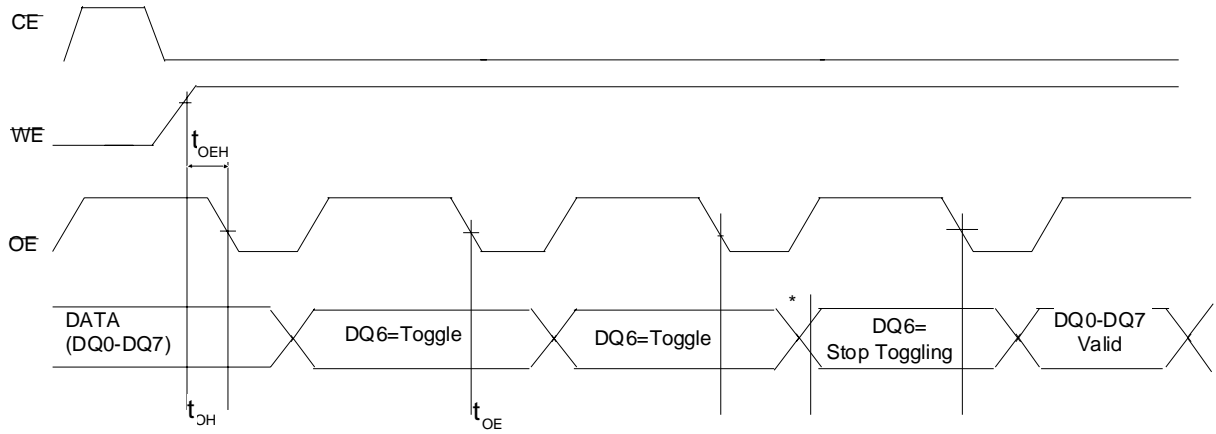

\* DQ6 stops toggling ( the device has completed the embedded operations)

### AC Waveforms For Sector Protection

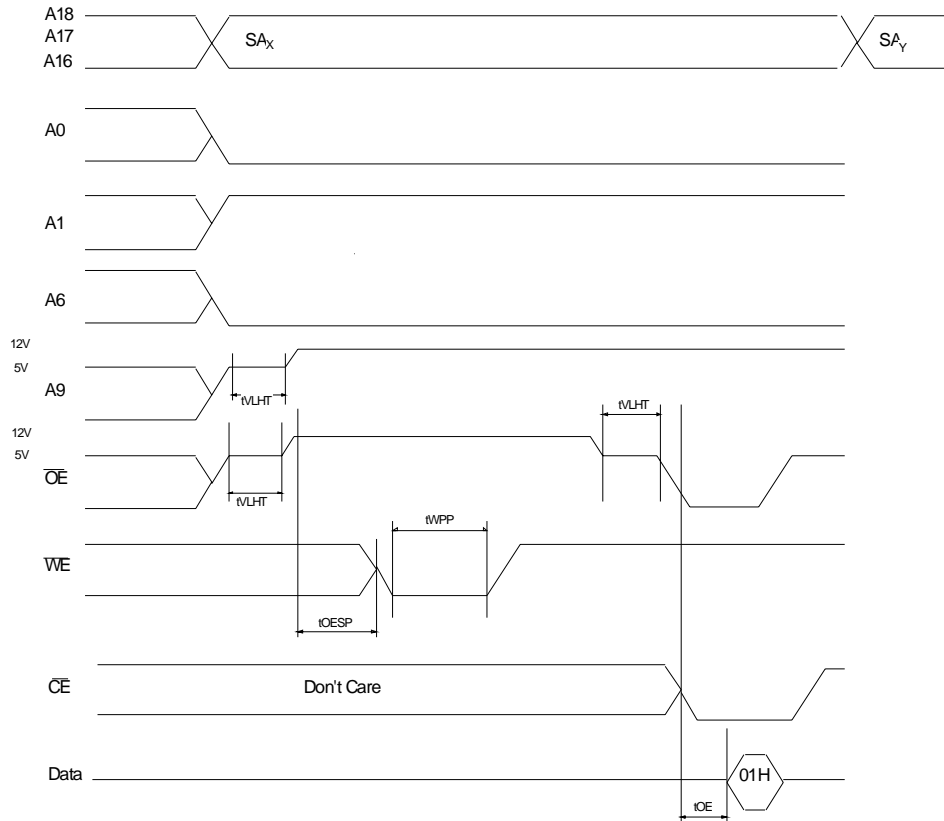

SA<sub>x</sub> = sector Addr for initial sector  
 SA<sub>y</sub> = sector Addr for next sector

### AC Waveforms for Sector Unprotect

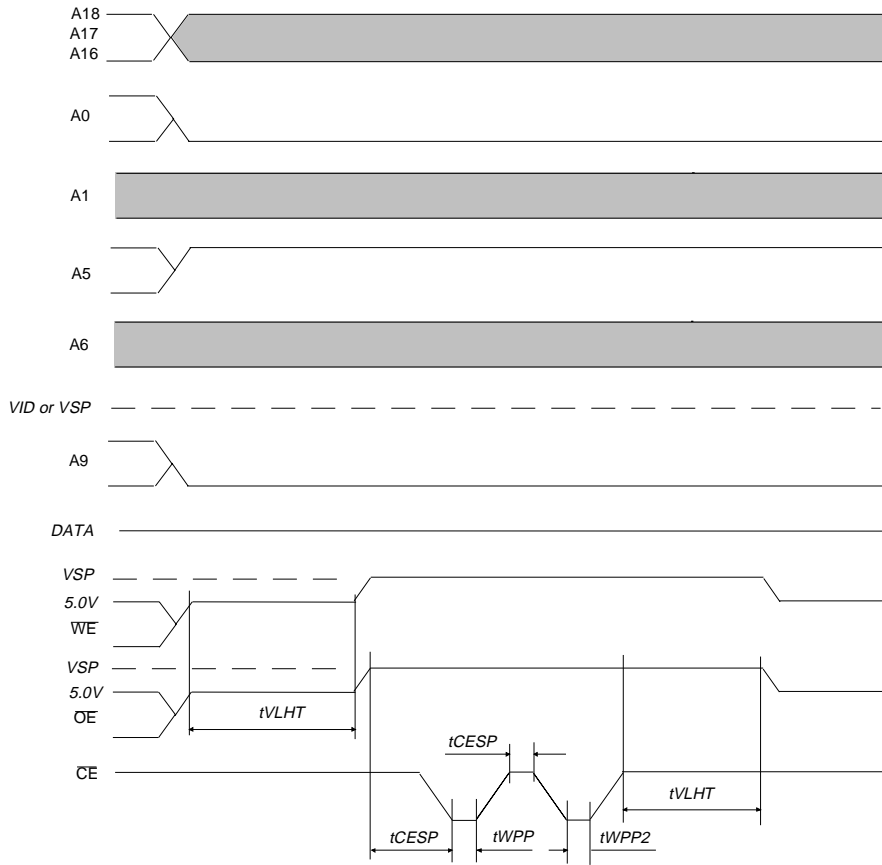

### AC Waveforms Chip / Sector Erase

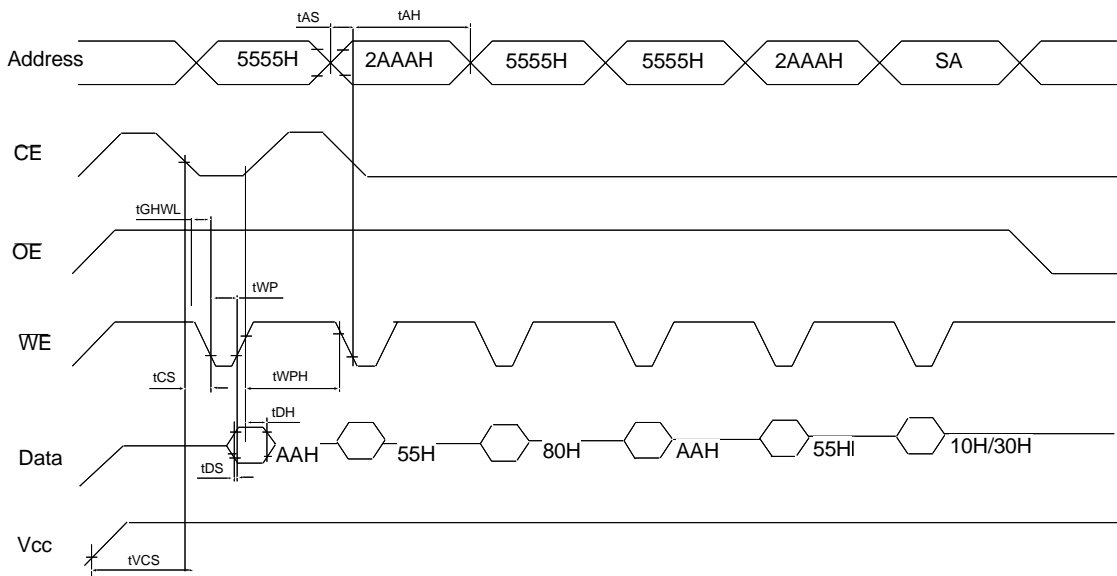

**NOTES:**

1. SA is the address for sector erase. Addresses = don't care for Chip Erase.

**EMBEDDED PROGRAMMING ALGORITHM**

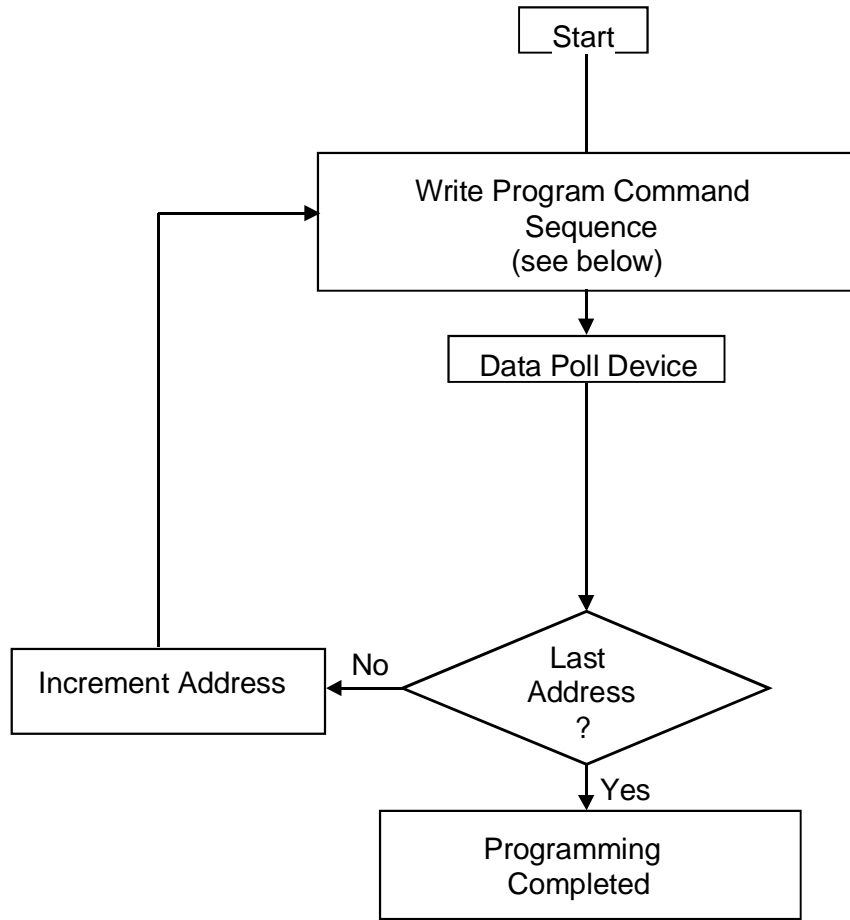

Program Command Sequence (Address /Command)

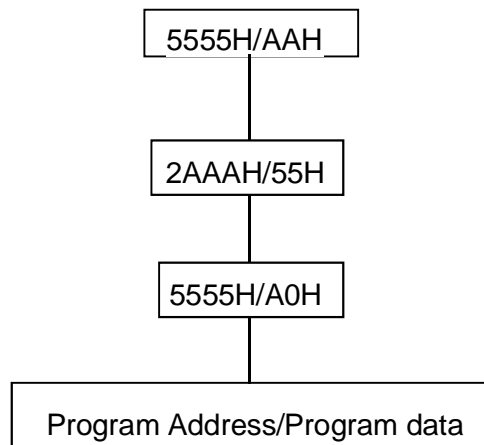

## EMBEDDED ERASE ALGORITHM

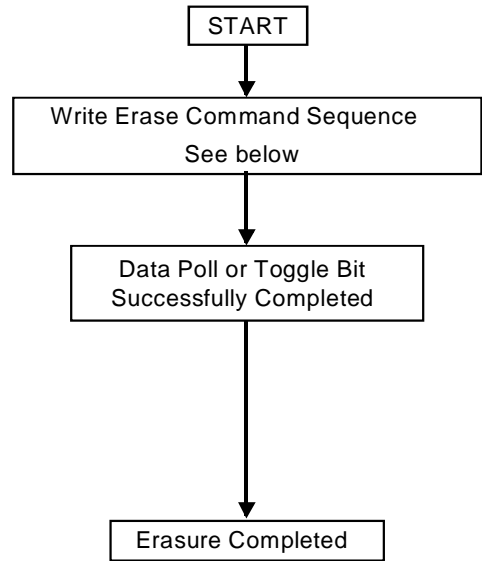

Chip Erase Command Sequence  
(Address/Command):

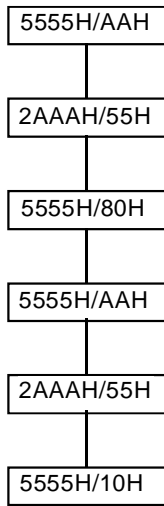

Individual Sector/Multiple Sector  
Erase Command Sequence  
(Address/Command):

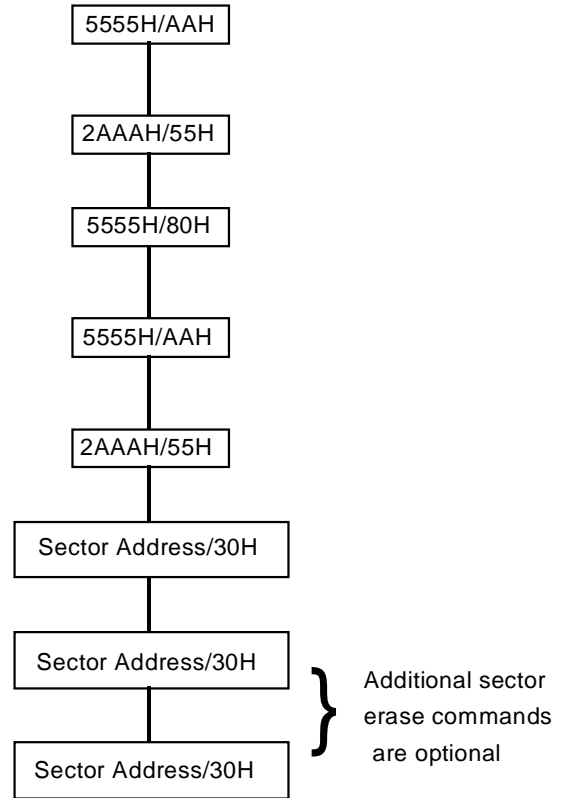

**DATA POLLING ALGORITHM**

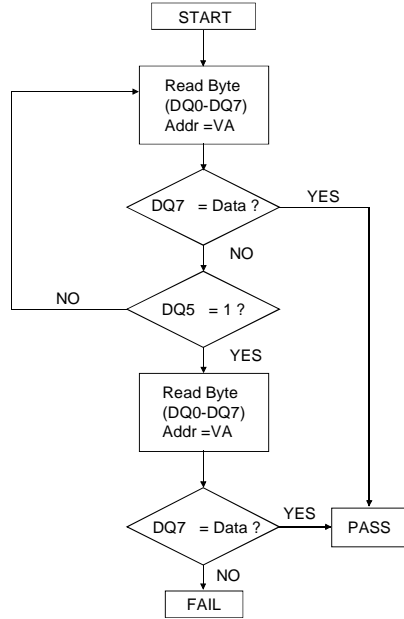

**NOTE:**

1. DQ7 is rechecked even if DQ5 = 1 because DQ7 may change simultaneously with DQ5.
2. VA = Byte address for programming.  
 = Any of the sector addresses within the sector being erased during sector erase operation  
 = XXXXXH during chip erase

**TOGGLE BIT ALGORITHM**

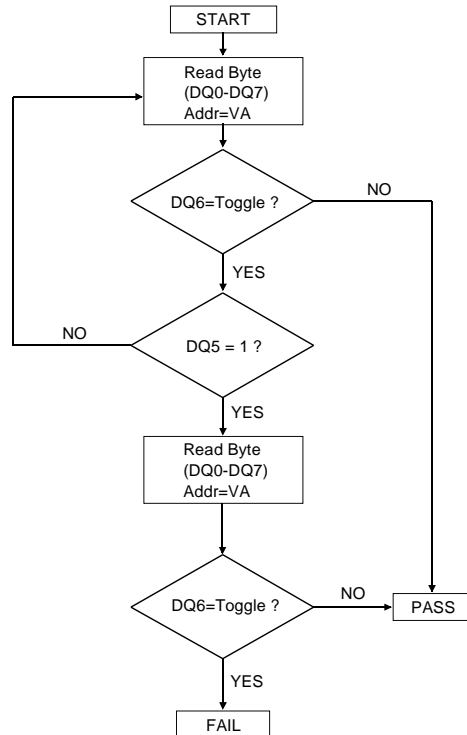

**NOTES:**

1. DQ6 is rechecked even if DQ5 = 1 because DQ6 may stop toggling at the same time as DQ5 changing to "1".
- 2 VA = As above.

**SECTOR UNPROTECT ALGORITHM**

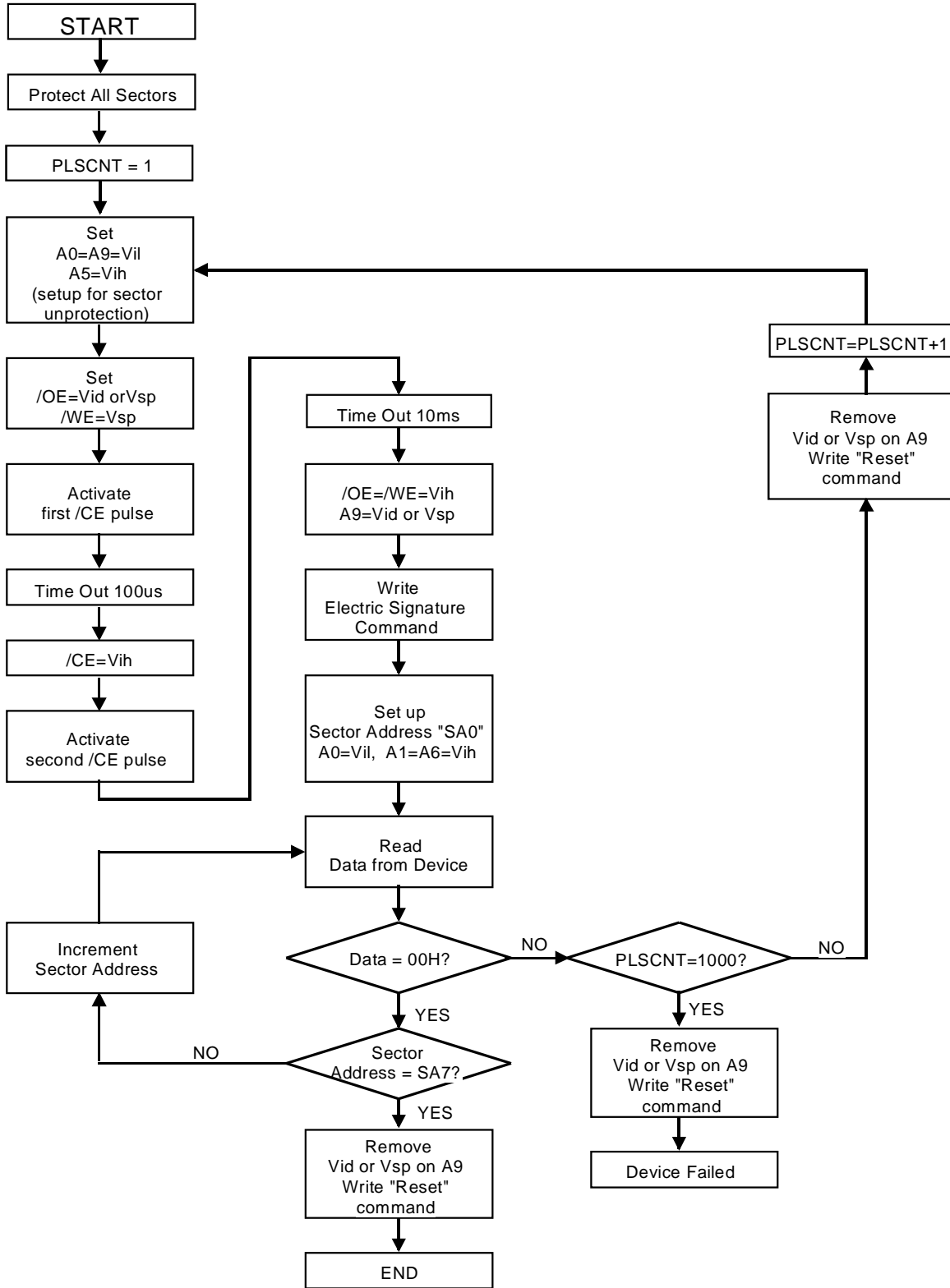

**NOTES:**

SA0 = The First Sector Address  
 SA7 = The Last Sector Address  
 (Sector Address is indicated using A16 to A18)

**SECTOR PROTECTION ALOGORITHM**

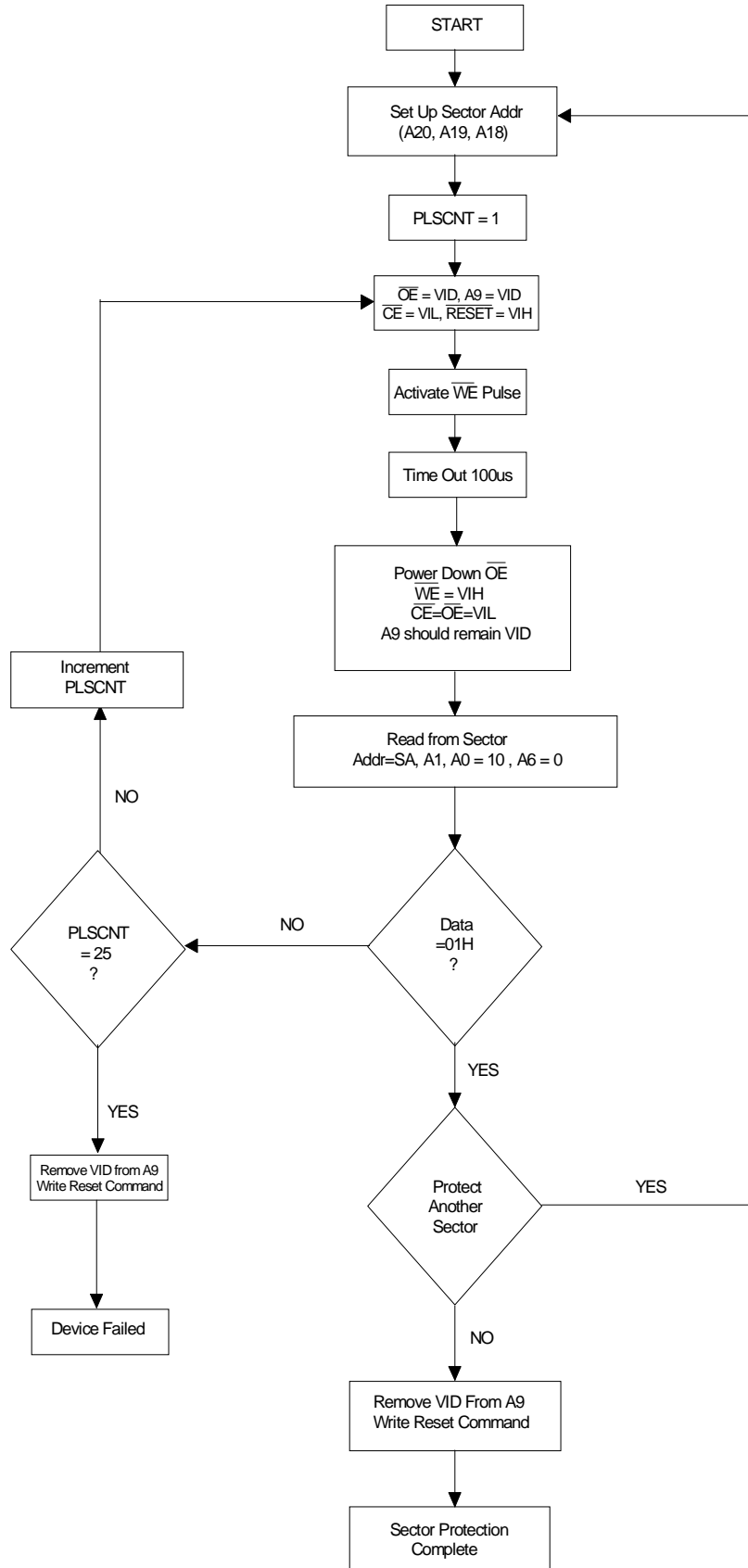

## DEVICE OPERATION

The following description deals with the device operating in 8 bit mode accessed through  $\overline{CE1}$ , however status flag definitions shown apply equally to the corresponding flag for each device in the module.

### Read Mode

The device has two control functions which must be satisfied in order to obtain data at the outputs  $\overline{CE1-4}$  is the power control and should be used for device selection  
 $\overline{OE}$  is the output control and should be used to gate data to the output pins if the device is selected.

### Standby Mode

Two standby modes are available :

CMOS standby :  $\overline{CE1-4}$  held at  $V_{CC} \pm 0.5V$

TTL standby :  $\overline{CE1-4}$  held at  $V_{IH}$

In the standby mode the outputs are in a high impedance state independent of the  $\overline{OE}$  input. If the device is deselected during erasure or programming the device will draw active current until the operation is completed.

### Output Disable

With the  $\overline{OE}$  input at a logic high level ( $V_{IH}$ ), output from the device is disabled. This will cause the output pins to be in a high impedance state.

### Autoselect

The autoselect mode allows the reading out of a binary code from the device and will identify the die manufacturer and type. This mode is intended for use by programming equipment. This mode is functional over the full military temperature range. The autoselect codes for the first device are as follows :

Type	A18	A17	A16	A6	A1	A0	Code (HEX)	DQ7	DQ6	DQ5	DQ4	DQ3	DQ2	DQ1	DQ0
Manufacture Code	X	X	X	$V_{IL}$	$V_{IL}$	$V_{IL}$	04H	0	0	0	0	0	0	0	1
Device Code	X	X	X	$V_{IL}$	$V_{IL}$	$V_{IH}$	A4H	1	0	1	0	0	1	0	0
Sector Protection	Sector Address		$V_{IL}$	$V_{IH}$	$V_{IL}$	01H*	0	0	0	0	0	0	0	1	

\* Outputs 01H at protected sector address

To activate this mode the programming equipment must force  $V_{ID}$  on address A9 . Two identifier bytes may then be sequenced from each die device outputs by toggling A0 from  $V_{IL}$  to  $V_{IH}$ . All addresses are don't care apart from A1 & A0. All identifiers for manufacturer and device will exhibit odd parity with D7 defined as the parity bit. In order to read the proper device codes when executing the autoselect A1 must be  $V_{IL}$ .

### Write

Device erasure and programming are accomplished via the command register. The contents of the register serve as inputs to the internal state machine. The state machine outputs dictate the function of the device. The register is a latch used to store the commands along with the address and data information required to execute the command. The command register is written by bringing  $\overline{WE}/\overline{WE1-4}$  to  $V_{IL}$  while  $\overline{CE1-4}$  is at  $V_{IL}$  and  $\overline{OE}$  is at  $V_{IH}$ . Addresses are latched on the falling edge of  $\overline{WE}/\overline{WE1-4}$  while data is latched on the rising edge.

## COMMAND DEFINITIONS

Device operations are selected by writing specific address and data sequences into the command register. The following table defines these register command sequences.

Command Sequence Read/Reset	Bus Write Cycles Req'd	First Bus Write Cycle		Second Bus Write Cycle		Third Bus Write Cycle		Fourth Bus Read/Write Cycle		Fifth Bus Write Cycle		Sixth Bus Write Cycle	
		Addr	Data	Addr	Data	Addr	Data	Addr	Data	Addr	Data	Addr	Data
Read/Reset	1	XXXH	F0H										
Read/Reset	4	5555H	AAH	2AAAH	55H	5555H	F0H	RA	RD				
Autoselect	4	5555H	AAH	2AAAH	55H	5555H	90H						
Byte Program	4	5555H	AAH	2AAAH	55H	5555H	A0H	PA	Data				
Chip Erase	6	5555H	AAH	2AAAH	55H	5555H	80H	5555H	AAH	2AAAH	55H	5555H	10H
Sector Erase	6	5555H	AAH	2AAAH	55H	5555H	80H	5555H	AAH	2AAAH	55H	SA	30H
Sector Erase Suspend		Erase can be suspended during sector erase with Addr (don't care) Data (B0H)											
Sector Erase Resume		Erase can be resumed after suspend with Addr (Don't Care), Data (30H)											

### NOTES:

- Address bit A15,A16,A17, A18=X=Don't care. Write Sequences may be initiated with A15, A17 and A18 in either state.
- Address bit A15,A16,A17, A18=X=Don't care for all address commands except for Program Address (PA) and Sector Address (SA).
- RA=Address of the memory location to be read.  
PA=Address of memory location to be programmed. Addresses are latched on the falling edge of the  $\overline{WE}$  pulse .  
SA=Address of the sector to be erased. The combination of A18, A17 and A16 will uniquely select any sector.
- RD=Data read from location RA during read operation.  
PD=Data to be programmed at location PA. Data is latched on the falling edge of  $\overline{WE}$

## Read / Reset Command

The read or reset operation is initiated by writing the read/reset command sequence into the command register. Microprocessor read cycles retrieve array data from the memory. The device remains enabled for reads until the command register contents are altered.

The device will automatically power-up in the read/reset state. In this case, a command sequence is not required to read data. Standard microprocessor read cycles will retrieve array data. This default value ensures that no spurious alteration of memory content occurs during the power transition. Refer to the AC Read Characteristics and Waveforms for specific timing parameters.

## Sector Protection

The device features hardware sector protection. This feature will disable both program and erase operations in any number of sectors (0 through 8). The sector protect feature is enabled using programming equipment at the users site. The device is shipped with all sectors unprotected.

To activate this mode, the programming equipment must force  $V_{ID}$  on address pin  $A_9$  and control pin  $\overline{OE}$ , and  $\overline{CE}=V_{IH}$ . The sector addresses (A18, A17 and A16) should be set to the sector to be protected. Programming of the protection circuitry begins on the falling edge of the  $\overline{WE}$  pulse and is terminated with the rising edge of the same. Sector addresses must be held constant during the  $\overline{WE}$  pulse.

To verify programming of the protection equipment circuitry, the programming equipment must force  $V_{ID}$  on address pin  $A_9$  with  $\overline{CE}$  and  $\overline{OE}$  at  $V_{IL}$  and  $\overline{WE}$  at  $V_{IH}$ . Reading the device at a particular sector address (A16, A17 and A18) while (A6,A1,A0) = (0,1,0) will produce 01H at data output D0 for a protected sector. Otherwise the device will read 00H for unprotected sector. In this mode, the lower order addresses, except for  $A_0$ ,  $A_1$  and  $A_6$ , are don't care. Address with  $A_1=V_{IL}$  are reserved for autoselect codes. If a verify of the sector protection circuitry were done at these addresses, the device would output the manufacturer and device codes respectively.

It is also possible to determine if a sector is protected in the system by writing the autoselect command. Performing a read operation at XX02H, where the higher order addresses (A16, A17, A18) are sector addresses,(other addresses are a don't care) will produce 01H data if those sectors are protected. Otherwise the device will read 00H for an unprotected sector.

### Sector Address Table

	A18	A17	A16	Address Range
SA0	0	0	0	00000h-0FFFFh
SA1	0	0	1	10000h-1FFFFh
SA2	0	1	0	20000h-2FFFFh
SA3	0	1	1	30000h-3FFFFh
SA4	1	0	0	40000h-4FFFFh
SA5	1	0	1	50000h-5FFFFh
SA6	1	1	0	60000h-6FFFFh
SA7	1	1	1	70000h-7FFFFh

## Sector Unprotect

Sectors which have previously been protected from being programmed or erased may be unprotected using the Sector Unprotect Algorithm. All sectors must be placed in the protection mode using the protection algorithm before unprotection can proceed.

A special high voltage for unprotection  $V_{SP}$  is defined to be  $10V\pm 0.5V$ .

The unprotection mode is entered by setting  $\overline{OE}$  to  $V_{ID}$  or  $V_{SP}$ ,  $\overline{WE}$  to  $V_{SP}$ ,  $A_5$  to  $V_{IH}$  and  $A_0=A_9$  to  $V_{IL}$ . Unprotect is invoked by applying to negative pulses on  $\overline{CE}$  for a period of  $t_{WPP2}$ .

## Autoselect Command

Flash memories are intended for use in applications where the local CPU alters memory contents. As such, manufacture and device codes must be accessible while the device resides in the target systems. PROM programmers typically access the signature codes by raising A9 to a high voltage. However, multiplexing high voltage onto the address lines is not generally a desired system design practice.

The device contains an autoselect operation to supplement traditional PROM programming methodology. The operation is initiated by writing the autoselect command sequence into the command register. Following the command write, a read cycle from address XX00H retrieves the manufacture code of 01H. A read cycle from address XX01H returns the device code A4H. A read cycle from address XXX2H returns information as to which sectors are protected. All manufacturer and device codes will exhibit odd parity with the MSB (D7) defined as the parity bit.

To terminate the operation, it is necessary to write the read/reset command sequence into the register.

## Byte Programming

The device is programmed on a byte-by-byte basis. Programming is a four bus cycle operation. There are two "unlock" write cycle. These are followed by the program set-up command and data write cycles. Addresses are latched on the falling edge of  $\overline{WE}/\overline{WE1-4}$  or  $\overline{CE1-4}$ , whichever happens later, while the data are latched on the rising edge of  $\overline{WE}/\overline{WE1-4}$  or  $\overline{CE1-4}$  whichever happens first. The rising edge of  $\overline{WE}/\overline{WE1-4}$  or  $\overline{CE1-4}$  begins programming. Upon executing the Embedded Program Algorithm Command sequence the system is not required to provide further controls or timings. The device will automatically provide adequate internally generated program pulses and verify the programmed cell margin. The automatic programming operation is completed when the data on D7 is equivalent to data written to this bit (see written Operations Status) at which time the device returns to read mode. Data Polling must be performed at the memory location which is being programmed.

Programming is allowed in any address sequence and across sector boundaries.

## Chip Erase

Chip erase is a six bus cycle operation. There are two "unlock" write cycles. These are followed by writing the "set-up" command. Two more "unlock" write cycles are then followed by the chip erase command.

Chip erase doesn't require the user to program the device prior to erase. Upon executing the Embedded Erase Algorithm command sequence the device automatically will program and verify the entire memory for an all zero data pattern prior to electrical erase. The systems is not required to provide any controls or timings during these operations.

The automatic erase begins on the rising edge of the last  $\overline{WE}$  pulse in the command sequence and terminates when the data on D7 is "1" (See Written Operation Section) at which time the device returns to read the mode.

---

## Sector Erase

---

Sector erase is a six bus cycle operation. There are two "unlock" write cycles. These are followed by writing the "Set-up" command. Two more "unlock" write cycles are then followed by the sector erase command. The sector address (any address location within the desired sector) is latched on the falling edge of  $\overline{WE}$ , while the command (data) is latched on the rising edge of  $\overline{WE}$ . A time-out of 50us from the rising edge of the last sector erase command will initiate the sector erase command(s).

Multiple sectors may be erased concurrently by writing the six bus cycle operations as described above. This sequence is followed with writes of the sector erase command 30H to addresses in other sectors required to be concurrently erased. A time-out of 50us from the rising edge of the  $\overline{WE}$  pulse for the last sector erase command will initiate the sector erase. If another sector erase command is written within the 50us time-out window the timer is reset. Any command other than sector erase within the time-out window will reset the device to the read mode, ignoring the previous command string (refer to Write Operation Status section for Sector Erase Timer operation). Loading the sector erase buffer may be done in any sequence and with any number of sectors (0 to 7).

Sector erase doesn't require the user to program the device prior to erase. The device automatically programs all memory locations in the sector(s) to be erased prior to electrical erase. When erasing a sector or sectors the remaining unselected sectors are not affected. The system is not required to provide any controls or timings during these operations.

The automatic sector erase begins after the 50us time-out from the rising edge of the  $\overline{WE}$  pulse for the last sector erase command pulse and terminates when the data on D7 is "1" ( see Written Operation Status Section) at which time the device returns to read mode. Data polling must be performed at an address within any of the sectors being erased.

---

## Erase Suspend

---

Erase suspend allows the user to interrupt the chip and read data (not program) from a non busy sector while it is in the middle of a sector erase operation, which may take several seconds.

The command can only be used during sector erase operation and otherwise will be ignored. The erase suspend command B0h is also allowed during the Sector Erase Operation that will include the sector erase time out period after the sector erase commands B0h. Writing this command during the timeout will result in immediate termination of the time out period and any subsequent writes of Sector Erase Command will be taken as Erase Resume.

To suspend the erase operation and go into erase suspend mode (pseudo read mode) requires between 0.1 and 10 $\mu$ s, during which time the user can read from a sector that is not being erased. The toggle bit stops toggling when the device enters pseudo read mode and an address of a sector not being erased must be used to read the toggle bit.

After the user writes the erase suspend command and waits until the toggle bit stops toggling, data reads from the device may then be performed. After an Erase Resume command the internal counters, which are used to count the high voltage pulses required to program or erase, are reset. The Exceed Time limit flag D5 is set if the count exceeds a certain limit. (The resetting of the counters is necessary as the erase suspend command can potentially interrupt the high voltage pulses.)

## Operating Modes

The following modes are used to control the device.

OPERATION	$\overline{CE}$	$\overline{OE}$	$\overline{WE}$	A0	A1	A6	A9	I/O
Auto-Select Manufacturer Code	L	L	H	L	L	L	V <sub>ID</sub>	Code
Auto Select Device Code	L	L	H	H	L	L	V <sub>ID</sub>	Code
Read <sup>(1)</sup>	L	L	H	A0	A1	A6	A9	D <sub>OUT</sub>
Standby	H	X	X	X	X	X	X	High Z
Output Disable	L	H	H	X	X	X	X	High Z
Write	L	H	L	A0	A1	A6	A9	Din
Enable Sector Protect	L	V <sub>ID</sub>	L	X	X	X	V <sub>ID</sub>	X
Verify Sector Protect	L	L	H	L	H	L	V <sub>ID</sub>	Code

1) L=V<sub>IL</sub>, H=V<sub>IH</sub>, X=Don't Care

NOTE: 1)  $\overline{WE}$  can be V<sub>IL</sub> if  $\overline{OE}$  is V<sub>IL</sub>,  $\overline{OE}$  at V<sub>IH</sub> initiates write cycle.

## WRITE OPERATIONS STATUS

### HARDWARE SEQUENCE FLAGS

	STATUS	D7	D6	D5	D3	D2-D0
In Progress	Auto-Programming	DQ <sub>7</sub>	Toggle	0	0	$\overline{(D)}$
	Programming in auto erase	0	Toggle	0	1	
	Erasing in Auto Erase	0	Toggle	0	1	
Exceeded Time limits	Auto-Programming	DQ <sub>7</sub>	Toggle	1	1	$\overline{(D)}$
	Programming in auto erase	0	Toggle	1	1	
	Erasing in Auto-Erase	0	Toggle	1	1	

**NOTE:** DQ0, DQ1, DQ2, DQ4 are reserve pins for future use.

### D7 Data Polling

The device features Data Polling as a method to indicate to the host system that the Embedded Algorithms are in progress or completed.

During the Embedded Programming Algorithm, an attempt to read the device will produce complement data of the data last written to D7. Upon completion of the Embedded Programming Algorithm an attempt to read the device will produce the true data last written to D7. Data Polling is valid after the rising edge of the forth  $\overline{WE}$  pulse in the four write pulse sequence.

During the Embedded Erase Algorithm, D7 will be "0" until the erase operation is completed. Upon completion data at D7 is "1". For chip erase, the Data Polling is valid after the rising edge of the sixth  $\overline{WE}$  pulse in the six write pulse sequence. For sector erase, Data Polling is valid after the last rising edge of the sector erase  $\overline{WE}$  pulse.

The Data Polling feature is only active during the Embedded Programming Algorithm, Embedded Erase Algorithm, or sector erase time-out.

---

## D<sub>6</sub> Toggle Bit

---

The device also features the "toggle bit" as a method to indicate to the host system that the Embedded Algorithms are in progress or completed.

During an Embedded Program or Erase Algorithm cycle, successive attempts to read data from the device will result in D<sub>6</sub> toggling between one and zero. Once the Embedded Program or Erase Algorithm cycle is completed, D<sub>6</sub> will stop toggling and valid data will be read on successive attempts. During programming, the Toggle bit is valid after the rising edge of the forth  $\overline{WE}$  pulse in the four write pulse sequence. For chip erase, the Toggle bit is valid after the last rising edge of the sector erase  $\overline{WE}$  pulse. The Toggle Bit is active during the sector time-out.

---

## D<sub>5</sub> Exceeding Time Limits

---

D<sub>5</sub> will indicate if the program or erase time has exceeded the specified limits. Under these conditions D<sub>5</sub> will produce "1", indicating the program or erase cycle was not successfully completed.  $\overline{Data}$  Polling is the only operating function of the device under this condition. The  $\overline{CE}$  circuit will partially power down the device under these conditions (to approximately 2mA). The  $\overline{OE}$  and  $\overline{WE}$  pins will control the output disable functions. To reset the device, write reset command sequence to the device. This allows the system to continue to use the other active sectors in the device, if this failure occurs during sector erase operations, it specifies that a particular sector is bad and may not be re-used. The device must be reset to use other sectors. While the reset command sequence and execute program or erase command sequence.

If this failure occurs during chip erase operation, it specifies that the device chip or combination of sectors are bad. If this failure occurs during the byte programming operation, it specifies that the active sectors containing that byte is bad and may not be re-used.

The D<sub>5</sub> failure condition may also appear if the user tries to program a non blank location without erasing. In this case the device locks out and never completes the embedded algorithm operation. Hence the system never reads a valid data on D<sub>7</sub> and D<sub>6</sub> never stops toggling. Once the device has exceeded timing limits, the D<sub>5</sub> bit will indicate '1'

---

## D<sub>4</sub> Hardware Sequence Flag

---

If the device has exceeded the specified erase or program time and D<sub>5</sub> is "1", then D<sub>4</sub> will indicate at which step in the algorithm the device exceeded the limits. A "0" in D<sub>4</sub> indicates in programming, a "1" indicates an erase.

---

## D<sub>3</sub> Sector Erase Timer

---

After the completion of the initial sector erase command sequence the sector erase time-out will begin. D<sub>3</sub> will remain low until the time-out is complete.  $\overline{Data}$  Polling and Toggle Bit are valid after the initial sector erase command sequence.

If  $\overline{Data}$  Polling or the Toggle Bit indicates the device has been written with a valid erase command, D<sub>3</sub> may be used to determine if the sector erase timer window is still open. If D<sub>3</sub> is high the internally controlled erase cycle has begun; attempts to write subsequent commands to the device will be ignored until the erase operation is completed as indicated by  $\overline{Data}$  Polling or Toggle Bit. If D<sub>3</sub> is low, the device will accept additional sector erase commands. To insure the command has been accepted, the software should check the status of D<sub>3</sub> prior to and following each subsequent sector erase command. If D<sub>3</sub> were high on the second status check, the command may not have been accepted.

## DATA PROTECTION

The device is designed to offer protection against accidental erasure or programming caused by spurious system level signals that may exist during power transition. During power up the device automatically resets the internal state machine in the Read mode. Also, with its controls register architecture, alteration of the memory contents only occurs after successful completion of specific multi-bus cycle command sequences. The device also incorporates several features to prevent inadvertent write cycles resulting from V<sub>CC</sub> power up and power down transitions or system noise.

### Low V<sub>CC</sub> Write Inhibit

To avoid initiation of a write cycle during V<sub>CC</sub> power up and power down, a write cycle is locked out for V<sub>CC</sub> less than 3.2V (typically 3.7V). If V<sub>CC</sub> < V<sub>LKO</sub>, the command register is disabled and all internal program/erase circuits are disabled. Under this condition the device will reset to read mode. Subsequent writes will be ignored until the V<sub>CC</sub> level is greater than V<sub>LKO</sub>. It is usually correct to prevent unintentional writes when V<sub>CC</sub> is above 3.2V.

### Write Pulse "Glitch" Protection

Noise pulses of less than 5ns (typical) on  $\overline{OE}$ ,  $\overline{CE}$ ,  $\overline{WE}$  will not initiate a write cycle

### Logical Inhibit

Writing is inhibited by holding any one of  $\overline{OE}=V_{IL}$ ,  $\overline{CE}=V_{IH}$  or  $\overline{WE}=V_{IH}$ . To initiate a write cycle  $\overline{CE}$  and  $\overline{WE}$  must be logical zero while OE is a logical one.

### Power Up Write Inhibit

Power-up of the device with  $\overline{WE}=\overline{CE}=V_{IL}$  and  $\overline{OE}=V_{IH}$  will not accept commands on the rising edge of  $\overline{WE}$ . The internal state machine is automatically reset to the read mode on power-up.

### Sector Protect

Sectors of the device may be hardware protected at the users factory. The protection circuitry will disable both program and erase functions for the protected sector(s). Requests to program or erase a protected sector will be ignored by the device.

## ERASE AND PROGRAMMING PERFORMANCE

Parameter	Limits			Unit	Comments
	Min	Typ	Max		
Sector Erase Time	1	30 (Note 1)		sec	Excludes 00H programming prior to erasure.
Byte Programming Time		16	1000 (Note 2)	us	Excludes System-level overhead.
Chip Programming Time		8.0 (Note 1)	50	sec	Excludes system-level overhead.
Erase/Program Cycles	100,000	1,000,000		cycles	10,000 Min for none E variant

**Notes:** (1) 25°C, 5V V<sub>CC</sub>, 100,000 cycles.

(2) The Embedded Algorithms allow for 48ms byte program time.

**Version 'A' Pin Definition** **Version 'A' Block Diagram**

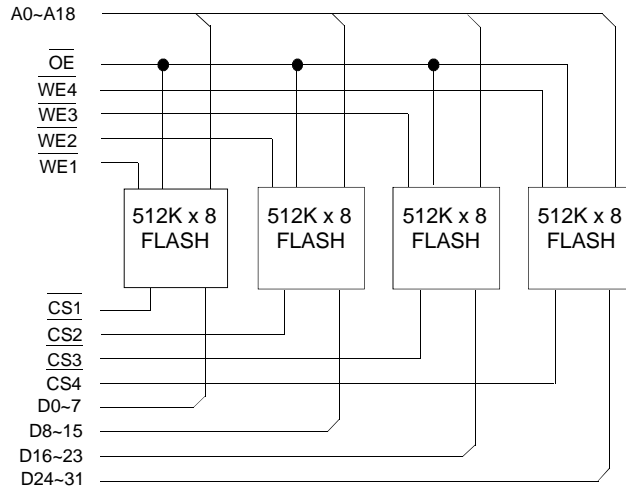
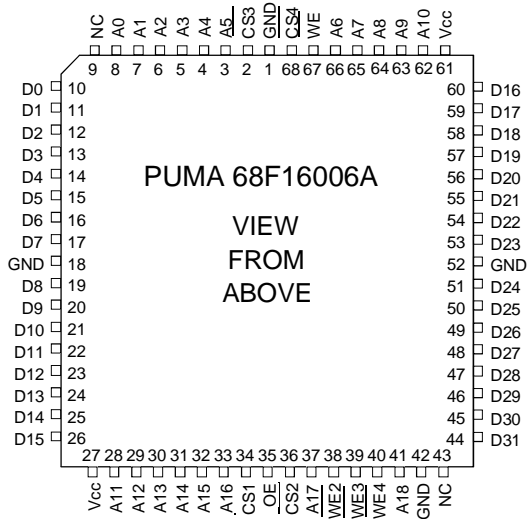

**SCREENING**

**Military Screening Procedure**

Screening Flow for high reliability product is in accordance with Mil-883 method 5004 .

<b>MB MODULE SCREENING FLOW</b>		
<b>SCREEN</b>	<b>TEST METHOD</b>	<b>LEVEL</b>
<b>Visual and Mechanical</b> Temperature cycle	1010 Condition B (10 Cycles, -55°C to +125°C)	100%
<b>Burn-In</b> Pre-Burn-in electrical Burn-in	Per applicable device specifications at $T_A = +25^\circ\text{C}$ $T_A = +125^\circ\text{C}$ , 160hrs minimum.	100% 100%
<b>Final Electrical Tests</b> Static (DC)  Functional  Switching (AC)	Per applicable Device Specification a) @ $T_A = +25^\circ\text{C}$ and power supply extremes b) @ temperature and power supply extremes  a) @ $T_A = +25^\circ\text{C}$ and power supply extremes b) @ temperature and power supply extremes  a) @ $T_A = +25^\circ\text{C}$ and power supply extremes b) @ temperature and power supply extremes	100% 100% 100% 100% 100%
<b>External Visual</b>	2009 Per vendor or customer specification	100%

**Package Information**      Dimensions in mm(inches)

**Plastic 68 Pin JEDEC Surface mount PLCC**

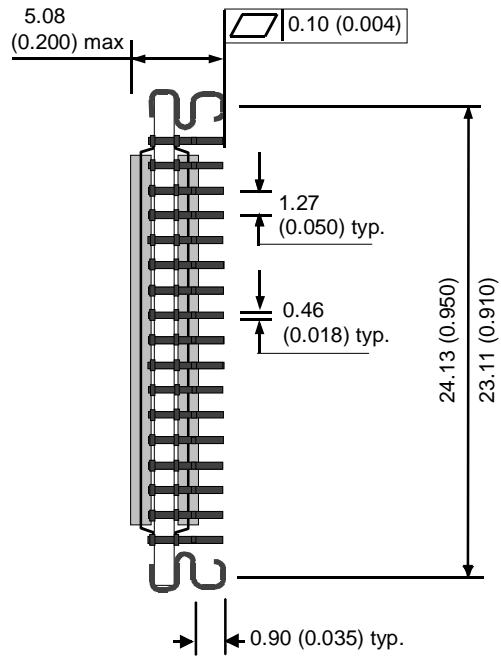
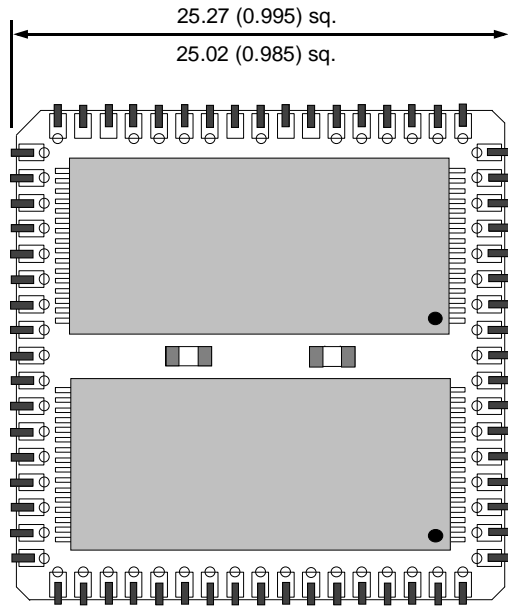

**Ordering Information**

**PUMA 68F16006AMB-70E**

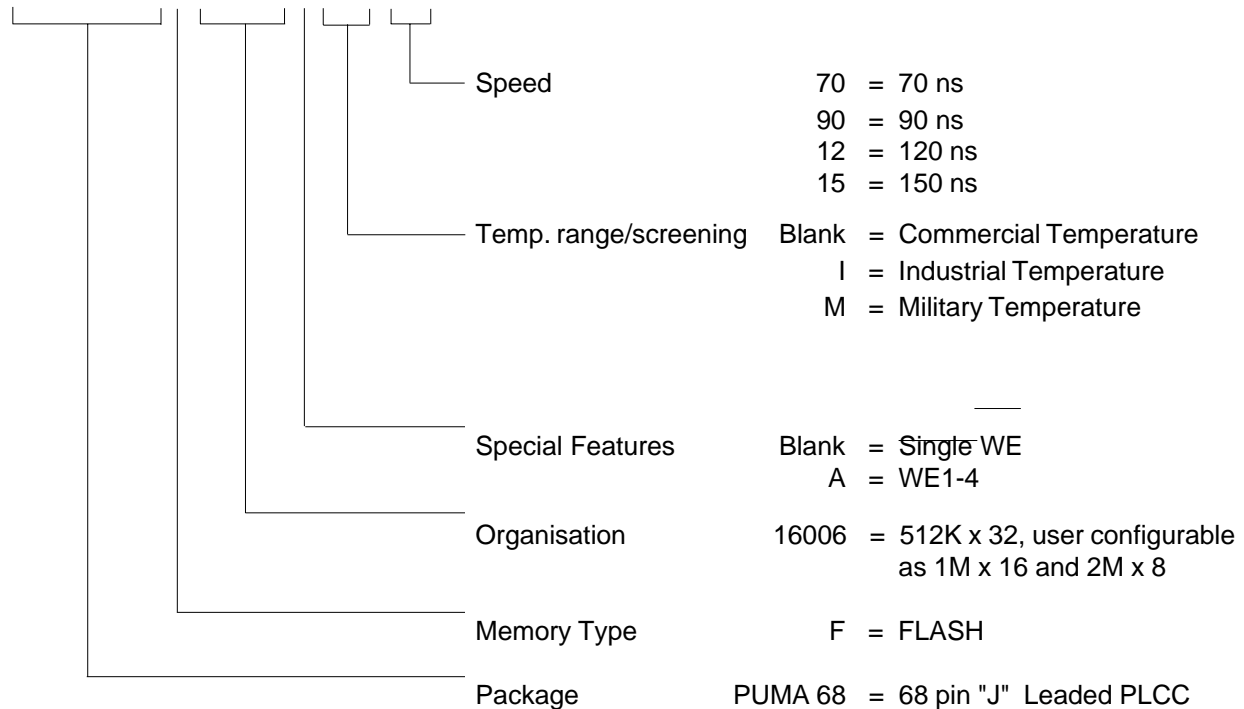

NOTE: The E variant is designated to parts with extended Erase/Write Cycle Endurance (100,000 Min.). If not specified when ordered only a Erase/Write Cycle Endurance of 10,000 Minimum can be guaranteed.

## Visual Inspection Standard

All devices inspected to ANSI/J-STD-001B Class 2 standard

## Moisture Sensitivity

Devices are **moisture sensitive**.

Shelf Life in Sealed Bag 12 months at <40°C and <90% relative humidity (RH).

After this bag has been opened, devices that will be subjected to infrared reflow, vapour phase reflow, or equivalent processing (peak package body temp 220°C) **must be** :

A : Mounted within 72 Hours at factory conditions of <30°C/60% RH

**OR**

B : Stored at <20% RH

If these conditions are not met or indicator card is >20% when read at 23°C +/-5% devices **require baking** as specified below.

If baking is required, devices may be baked for :-

A : 24 hours at 125°C +/-5% for high temperature device containers

**OR**

B : 192 hours at 40°C +5°C/-0°C and <5% RH for low temperature device containers.

## Packaging Standard

Devices packaged in dry nitrogen, JED-STD-020.

Packaged in trays as standard.

Tape and reel available for shipment quantities exceeding 200pcs upon request.

## Soldering Recommendations

IR/Convection -	Ramp Rate	6°C/sec max.
	Temp. exceeding 183°C	150 secs. max.
	Peak Temperature	225°C
	Time within 5°C of peak	20 secs max.
	Ramp down	6°C/sec max.
Vapour Phase -	Ramp up rate	6°C/sec max.
	Peak Temperature	215 - 219°C
	Time within 5°C of peak	60 secs max.
	Ramp down	6°C/sec max.

The above conditions must not be exceeded.

*Note : The above recommendations are based on standard industry practice. Failure to comply with the above recommendations invalidates product warranty.*