

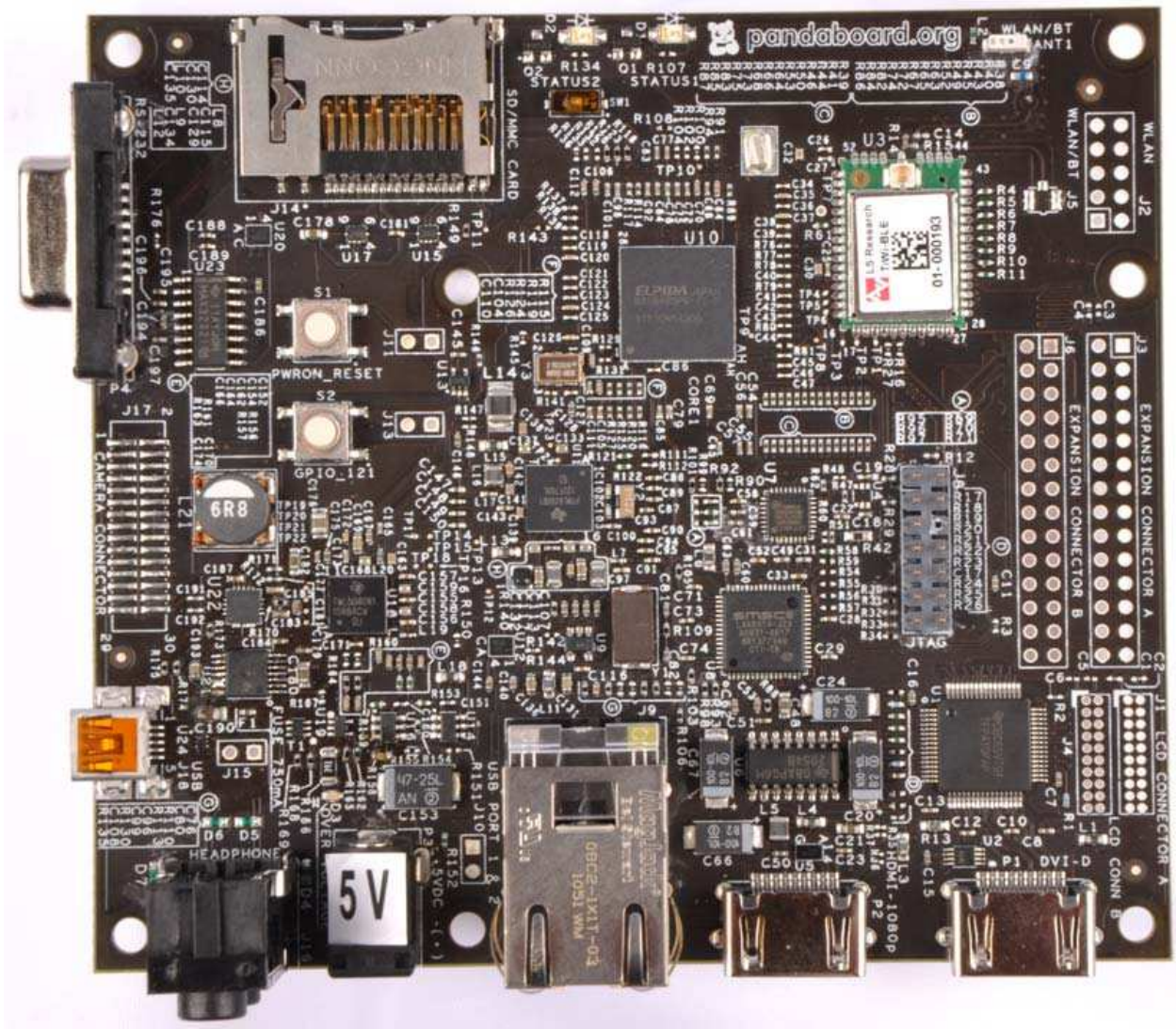

pandaboard.org

OMAP4460 Pandaboard ES System Reference Manual



IMPORTANT NOTICE

THIS DOCUMENT

This work is licensed under the Creative Commons Attribution-Share Alike 3.0 Unported License. To view a copy of this license, visit <http://creativecommons.org/licenses/by-sa/3.0/> or send a letter to Creative Commons, 171 Second Street, Suite 300, San Francisco, California, 94105, USA.

For more information, see <http://creativecommons.org/licenses/by-sa/3.0/>

For any questions, concerns, or issues submit them to Pandaboard@googlegroups.com

PANDABOARD ES DESIGN

These design materials referred to in this document are ***NOT SUPPORTED*** and **DO NOT** constitute a reference design. Only “community” support is allowed via resources at: <http://Pandaboard.org/content/community/home>.

THERE IS NO WARRANTY FOR THE DESIGN MATERIALS, TO THE EXTENT PERMITTED BY APPLICABLE LAW. EXCEPT WHEN OTHERWISE STATED IN WRITING THE COPYRIGHT HOLDERS AND/OR OTHER PARTIES PROVIDE THE DESIGN MATERIALS “AS IS” WITHOUT WARRANTY OF ANY KIND, EITHER EXPRESSED OR IMPLIED, INCLUDING, BUT NOT LIMITED TO, THE IMPLIED WARRANTIES OF MERCHANTABILITY AND FITNESS FOR A PARTICULAR PURPOSE. THE ENTIRE RISK AS TO THE QUALITY AND PERFORMANCE OF THE DESIGN MATERIALS IS WITH YOU. SHOULD THE DESIGN MATERIALS PROVE DEFECTIVE, YOU ASSUME THE COST OF ALL NECESSARY SERVICING, REPAIR OR CORRECTION.

We mean it; these design materials may be totally unsuitable for any purposes.

Pandaboard.org provides the enclosed product(s) under the following conditions:

This evaluation board/kit is intended for use for **ENGINEERING DEVELOPMENT, DEMONSTRATION, OR EVALUATION PURPOSES ONLY** and is not considered by Pandaboard.org to be a finished end-product fit for general consumer use. Persons handling the product(s) must have electronics training and observe good engineering practice standards. As such, the goods being provided are not intended to be complete in terms of required design-, marketing-, and/or manufacturing-related protective considerations, including product safety and environmental measures typically found in

end products that incorporate such semiconductor components or circuit boards. This evaluation board/kit does not fall within the scope of the European Union directives regarding electromagnetic compatibility, restricted substances (RoHS), recycling (WEEE), FCC, CE or UL, and therefore may not meet the technical requirements of these directives or other related directives.

Should this evaluation board/kit not meet the specifications indicated in the User's Guide, the board/kit may be returned within 30 days from the date of delivery for a full refund. THE FOREGOING WARRANTY IS THE EXCLUSIVE WARRANTY MADE BY SELLER TO BUYER AND IS IN LIEU OF ALL OTHER WARRANTIES, EXPRESSED, IMPLIED, OR STATUTORY, INCLUDING ANY WARRANTY OF MERCHANTABILITY OR FITNESS FOR ANY PARTICULAR PURPOSE.

The user assumes all responsibility and liability for proper and safe handling of the goods. Further, the user indemnifies Pandaboard.org from all claims arising from the handling or use of the goods. Due to the open construction of the product, it is the user's responsibility to take any and all appropriate precautions with regard to electrostatic discharge.

EXCEPT TO THE EXTENT OF THE INDEMNITY SET FORTH ABOVE, NEITHER PARTY SHALL BE LIABLE TO THE OTHER FOR ANY INDIRECT, SPECIAL, INCIDENTAL, OR CONSEQUENTIAL DAMAGES.

Pandaboard.org currently deals with a variety of customers for products, and therefore our arrangement with the user is **not exclusive**. Pandaboard.org assumes **no liability for applications assistance, customer product design, software performance, or infringement of patents or services described herein**.

Please read the User's Guide and, specifically, the Warnings and Restrictions notice in the User's Guide prior to handling the product. This notice contains important safety information about temperatures and voltages. For additional information on Pandaboard.org environmental and/or safety programs, please visit <http://Pandaboard.org>.

No license is granted under any patent right or other intellectual property right of Pandaboard.org covering or relating to any machine, process, or combination in which such Pandaboard.org products or services might be or are used.

WARRANTY: *The Pandaboard ES is warranted against defects in materials and workmanship for a period of 90 days from purchase. This warranty does not cover any problems occurring as a result of improper use, modifications, exposure to water, excessive voltages, abuse, or accidents. All boards will be returned via standard mail if an issue is found. If no issue is found or express return is needed, the customer will pay all shipping costs.*

Before returning the board, please visit:

<http://Pandaboard.org/content/resources/troubleshooting>.

To return a defective board, please request an RMA at:

<http://Pandaboard.org/content/return-merchandise-authorization>.



Preface

Read This First

About This Manual

This manual should be used by software and hardware developers of applications based on the OMAP4460 chipset. This document describes the OMAP4460 Pandaboard ES hardware. This document also gives the user information about the different interfaces on the OMAP4460 Pandaboard ES.

Related Documentation

- [OMAP4460 Technical Reference Manual](#)
- [OMAP4460 Pandaboard ES Schematic \(750-2170-002-SCH\)](#)
- [OMAP4460 Pandaboard ES Gerber Files \(720-2170-004\)](#)
- [OMAP4460 Pandaboard ES Bill-of-Materials \(750-2170-002-EBOM\)](#)



Revision History

Revision History

Rev	Changes	Date
0.1	Preliminary Release	29 Sept. 2011

Contents

1	Introduction.....	11
1.1	OMAP4460 Pandaboard ES Overview	12
1.2	Overview of the OMAP4460 Pandaboard ES Kit Contents.....	13
2	OMAP4460 Pandaboard ES Architecture.....	14
2.1	Overview of the Pandaboard ES Architecture	14
2.2	System Clock Distribution.....	17
2.3	OMAP4460 Processor.....	17
2.4	TPS62361 External Power Supply (VDD_MPU).....	18
2.5	TWL6030 Power Companion IC	18
2.5.1	TWL6030 Core SMPS Outputs	19
2.5.2	TWL6030 V1V8 SMPS Output.....	19
2.5.3	TWL6030 V2V1 SMPS Output.....	19
2.5.4	TWL6030 VMEM SMPS Output.....	19
2.5.5	TWL6030 V1V29 SMPS Output.....	19
2.5.6	TWL6030 LDO Power Resources.....	19
2.5.7	TWL6030 Clock Circuitry.....	20
2.6	TWL6040 Audio Companion IC	21
2.7	SYSBOOT Configuration.....	21
2.8	Miscellaneous Power Circuitry	26
2.8.1	Input Power Circuitry	26
2.8.2	USB/Ethernet Power Circuitry	27
2.9	Standard Volatile Memory.....	27
2.10	Debug UART Interface.....	28
2.11	SD/MMC Connector.....	28
2.12	HDMI Interface.....	29
2.13	Display Interface.....	31
2.13.1	Parallel Display Interface.....	32
2.13.2	DSI Display Expansion Connector Interface	34
2.14	Bluetooth/WLAN Interfaces.....	36
2.15	Audio Interfaces.....	38
2.16	USB Interfaces.....	39
2.16.1	USBOTG Interface	39
2.16.2	USBB1 Phy Interface.....	40
2.17	Expansion Connectors (J3 & J6).....	41
2.18	Camera Expansion Connector (J17).....	44
2.19	JTAG Connector (J8).....	45
2.20	LED Indicators.....	47
2.21	User Interface Features	48

2.21.1	S1 – Push Button Switch.....	48
2.21.2	S2 - Push Button Switch	48
2.21.3	SW1 – Dip/Slide Switch	48
2.22	I ² C Device Mapping.....	48
2.22.1	OMAP I ² C1.....	48
2.22.2	OMAP I ² C2.....	49
2.22.3	OMAP I ² C3.....	49
2.22.4	OMAP I ² C4.....	49
3	Pandaboard ES S/W Interface.....	50
3.1	Readable Board Revision.....	50
3.2	Pandaboard ES Pin Multiplexing.....	50
3.2.1	Panda Base Platform Pin Multiplexing.....	50
3.2.2	Camera Expansion Connector Pin Multiplexing.....	54
3.2.3	Expansion Connector (J3 & J6) Pin Multiplexing.....	54
3.3	OMAP4460 Pandaboard ES Key Components.....	56
3.4	OMAP4460 Pandaboard ES Key Component Datasheet URLs	58
3.4.1	Connector Datasheets	58
3.4.2	Key Electronic Component Datasheets.....	58
4	Test/Debug Information.....	60
4.1	Pandaboard ES Clock Signal Access.....	60
4.1.1	H_FREF_ALTCLK_IN_OMAP Probe Point.....	60
4.1.2	U\$BB1_PHY_REFCLK Probe Point.....	61
4.1.3	CLK32K_AUD Probe Point.....	62
4.2	Pandaboard ES Power Rail Signal Access.....	63
4.2.1	TWL6030 SMPS Output Probe Points.....	63
4.2.2	VDD_CORE1 Output Probe Point.....	63
4.2.3	VCXIO LDO Output Probe Point.....	64
4.3	Pandaboard ES Interface Signal Access.....	66
4.3.1	TWL6040 PDM Interface Probe Points.....	66
4.4	Pandaboard ES Schematic.....	67
4.5	Pandaboard ES Bill of Materials.....	82
4.6	Pandaboard ES PCB Design Information	82

Figures

Figure 1 – OMAP4460 Pandaboard ES Architectural Block Diagram.....	15
Figure 2 – OMAP4460 Pandaboard ES (Top View)	16
Figure 3 – SYSBOOT[5:0] Resistor Locations + SYSBOOT3 Switch Location.....	23
Figure 4 – Pandaboard ES Input Power Circuitry Block Diagram	26
Figure 5 – Panda UART3/RS-232 Block Diagram.....	28
Figure 6 – Panda SDMMC1 Card Cage Block Diagram	29
Figure 7 – Panda HDMI Interface Block Diagram	30
Figure 8 – Panda Display Interface Block Diagram	31
Figure 9 – Pandaboard ES DSS Output Block Diagram.....	32
Figure 10 – Panda DSI Display Connector Orientation.....	35
Figure 11 – Panda DSI Display Expansion Block Diagram	36
Figure 12 – Pandaboard ES WLAN/Bluetooth Interface Block Diagram	37
Figure 13 – Panda Audio Interface Block Diagram.....	39
Figure 14 – Panda USBOTG Interface Block Diagram.....	40
Figure 15 – Panda USBB1 Interface Block Diagram	41
Figure 16 – Expansion Connector PCB Placement/Orientation	42
Figure 17 – 14-pin JTAG Connector (J8)	46
Figure 18 – Pandaboard ES LED Locations	47
Figure 19 – 38.4 MHz Input Clock Probe Point (h_FREF_ALTCLK_IN_OMAP).....	61
Figure 20 – USB Phy Ref Clock In Probe Point (USBB1_PHY_REFCLK).....	61
Figure 21 – 32KHz Audio Clock Probe Point (CLK32K_AUD)	62
Figure 22 – TWL6030 SMPS Output Probe Points	63
Figure 23 – VDD_CORE1 Output Probe Point	64
Figure 24 – TWL6030 VCXIO LDO Output Probe Points	65
Figure 25 – TWL6040 PDM Interface Probe Points	66

Tables

Table 1: Pandaboard ES Features	12
Table 2: SYSBOOT[5:0] Definitions – Peripheral Preferred Booting	24
Table 3: SYSBOOT[5:0] Definitions – Memory Preferred Booting	25
Table 4: HDMI GPIO Definitions	31
Table 5: DVI-D Display GPIO Definitions	33
Table 6: LCD Expansion Connector “A” Pin Definitions (J1)	33
Table 7: LCD Expansion Connector “B” Pin Definitions (J4)	34
Table 8: DSI Display Expansion Connector Pin Definitions (J7)	35
Table 9: WLAN/Bluetooth Module GPIO Definitions	38
Table 10: USB Host Port/Ethernet GPIO Definitions	41
Table 11: Expansion Connector “A” Pin Definitions (J3)	43
Table 12: Expansion Connector “B” Pin Definitions (J6)	44
Table 13: Camera Expansion Connector Pin Definitions (J17)	45
Table 14: JTAG Connector Pinout (J8)	46
Table 15: OMAP I ² C1 Device Addresses	48
Table 16: OMAP I ² C2 Device Addresses	49
Table 17: OMAP I ² C3 Device Addresses	49
Table 18: OMAP I ² C4 Device Addresses	49
Table 19: Board ID Read Values	50
Table 20: Pandaboard ES OMAP4460 Pin Multiplexing	54
Table 21: Camera Expansion Connector (J17) Pin Multiplexing Options	54
Table 22: Expansion Connector (J3 & J6) Pin Multiplexing Options	55
Table 23: OMAP4460 Pandaboard ES Key H/W Components	57

1 Introduction

This document is the System Reference Manual for the Pandaboard ES, a low cost OMAP4460 based board supported through <http://Pandaboard.org>. This includes system setup and debugging. This document provides detailed information on the overall design and usage of the Pandaboard ES from the System perspective.

CAUTION: The Pandaboard ES may reach elevated temperatures. Avoid handling the Pandaboard ES while power is applied.

1.1 OMAP4460 Pandaboard ES Overview

Pandaboard ES is an OMAP4460 platform designed to provide access to as many of the powerful features of the OMAP4460 Multimedia Processor as possible, while maintaining a low cost. This will allow the user to develop software to utilize the features of the powerful OMAP4460 processor. In addition, by providing expandability via onboard connectors, the Pandaboard ES supports development of additional capabilities/functionality. See Table 1 for a listing of the Pandaboard ES features.

Feature		
Processor	OMAP4460	
POP Memory	Elpida 8Gb LPDDR2 (EDB8064B1PB-8D-F)	
PMIC	TI (TWL6030 Power Management Companion IC)	
Debug Support	14-pin JTAG	GPIO Pins
	UART via DB-9 connector	LEDs
PCB	4.5" x 4.0" (114.3 x 101.6 mm)	8 layers
Indicators	3 LEDs (two user-controlled, one overvoltage indicator)	
HS USB 2.0 OTG Port	Mini-AB USB connector, sourced from OMAP USB Transceiver	
HS USB Host Port	Four USB HS Ports, up to 500mA current out on each, two to onboard connectors, two to expansion connectors	
Audio Connectors	3.5mm, L+R out	3.5mm, Stereo In
SD/MMC Connector	6 in 1 SD/MMC/SDIO	4/8 bit support, Dual voltage
User Interface	1-User defined button	Reset Button
	SYSBOOT3 switch	
Video	DVI-D or HDMI	Optional user provided plug-in display
Power Connector	USB Power	DC Power
Camera	Not included, but supported via camera expansion connector	
Expansion Connectors (not populated)	See Paragraph 2.17 on page 41	
Parallel LCD Expansion Connectors (not populated)	See Paragraph 2.13.1 on page 32	
DSI LCD Expansion Connector (not populated)	See Paragraph 2.13.2 on page 34	

Table 1: Pandaboard ES Features

1.2 Overview of the OMAP4460 Pandaboard ES Kit Contents

The OMAP4460 Pandaboard ES kit contains the following items:

- 1 Pandaboard ES
- Board packing material
- 1 Shipping Box

The following items can be used with the Pandaboard ES, but are NOT included in the kit.

- USB Cable (mini-AB to Type A)
- HDMI Cable (Type A)
- DB-9 Male-to-female cable (straight-through)
- HDMI-A Male to DVI-D Cable
- DC wall supply (+5Vdc, 2.0mm center pin diameter/6.5mm outer hole diameter jack)

2 OMAP4460 Pandaboard ES Architecture

This chapter explains the architecture of the OMAP4460 Pandaboard ES.

2.1 Overview of the Pandaboard ES Architecture

Shown in Figure 1 is the Architectural Block Diagram of the OMAP4460 Pandaboard ES.

Listed below are the major components used on the Pandaboard ES.

- OMAP4460 Processor
- TWL6030 (Phoenix) Power Management Companion Device
- TWL6040 (Phoenix) Audio Companion Device
- TPS62361 Switching Power Supply
- POP Mobile LPDDR2 SDRAM Memory
- HDMI Connector (Type A) – for OMAP4460 HDMI Transmitter output
- HDMI Connector (Type A) – for DVI-D output sourced via OMAP4 parallel display output
- Audio Input & Output Connectors (3.5mm)
- SD/SDIO/MMC Media Card Cage
- UART via RS-232 interface via 9-pin D-Sub Connector
- LS Research Module – 802.11b/g/n, Bluetooth

The Platform also includes connectors that can be used for additional functionality and/or expansion purposes. These connectors are not populated on the platform, but can be installed by the user. They are indicated by the blue blocks in Figure 1, and include:

- Camera Connector (J17)
- Parallel LCD Expansion Connectors (J1 and J4)
- Generic Expansion Connectors (J3 and J6)
- DSI Display Expansion Connector (J7)

See Figure 2 on page 16 for a top side view of the Panda Platform.

The core components of the Pandaboard ES will be discussed in this section of the document. This would include the OMAP4460 Processor and its POP LPDDR2 memory, the input clock circuitry, the TWL6030 Power Companion IC, and the TWL6040 Audio Companion IC. The functional interfaces will be discussed in later sections of the document.

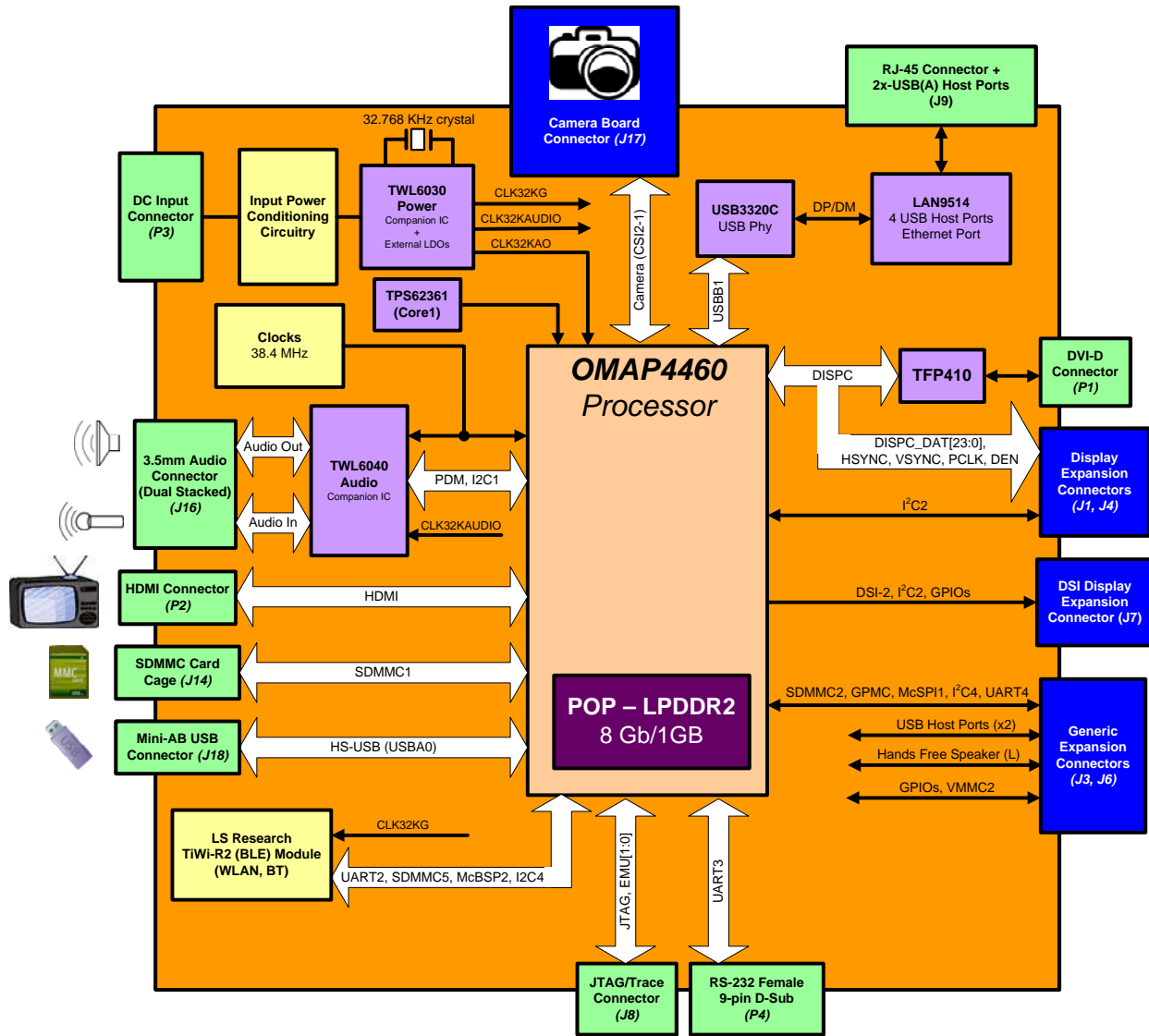

Figure 1 – OMAP4460 Pandaboard ES Architectural Block Diagram



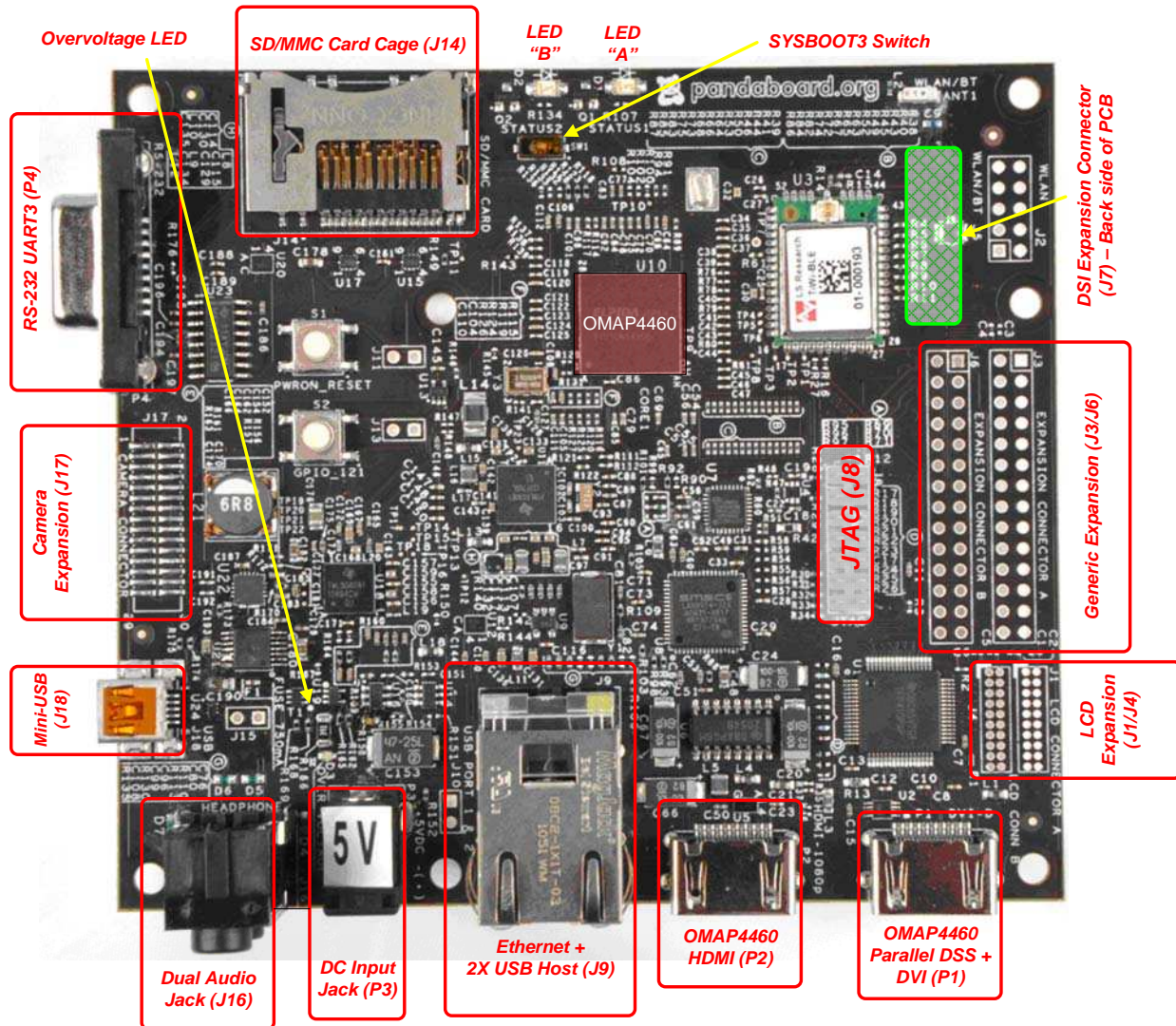

Figure 2 – OMAP4460 Pandaboard ES (Top View)

2.2 System Clock Distribution

The OMAP4460 Pandaboard ES implements a 38.4 MHz 1.8V CMOS square-wave oscillator that directly drives the FREF_SLICER_IN input (ball AG8) of the OMAP4460 processor and the MCLK input to the TWL6040 Audio Companion IC. This clock is used as an input to the PLLs within the OMAP4460 processor so that it can generate all the internal clock frequencies required for system operation.

2.3 OMAP4460 Processor

The heart of Pandaboard ES is the OMAP4460 processor. The OMAP4460 high-performance multimedia application device is based on enhanced OMAP™ architecture and uses 45-nm technology. For more information, refer to the OMAP4460 Technical Reference Manual (TRM). The architecture is designed to provide best-in-class video, image, and graphics processing sufficient to various applications. The device supports the following functions:

- Streaming video up to full high definition (HD) (1920 × 1080 p, 30 fps)
- 2-dimensional (2D)/3-dimensional (3D) mobile gaming
- Video conferencing
- High-resolution still image (up to 16 Mp)

The device supports high-level operating systems (OSs) such as:

- Windows™ CE, WinMobile™
- Symbian OS™
- Linux®
- Palm OS™

The device is composed of the following subsystems:

- Cortex™-A9 microprocessor unit (MPU) subsystem, including two ARM® Cortex-A9 cores capable of operation at 1.2GHz
- Digital signal processor (DSP) subsystem
- Image and video accelerator high-definition (IVA-HD) subsystem
- Cortex™-M3 MPU subsystem, including two ARM Cortex-M3 microprocessors
- Display subsystem
- Audio back-end (ABE) subsystem
- Imaging subsystem (ISS), consisting of image signal processor (ISP) and still image coprocessor (SIMCOP) block
- 2D/3D graphic accelerator (SGX) subsystem
- Emulation (EMU) subsystem

The device includes state-of-art power-management techniques required for high-performance mobile products. Comprehensive power management is integrated into the device. The device also integrates:

- On-chip memory
- External memory interfaces
- Memory management
- Level 3 (L3) and level 4 (L4) interconnects

- System and connecting peripherals

2.4 TPS62361 External Power Supply (VDD_MPU)

The VDD_MPU balls on the OMAP4460 processor that power the ARM cores are supplied by an external switch mode supply at U25. This device is a Texas Instruments TPS62361 switch mode supply that is controllable via the smart reflex I2C interface of the OMAP4460 processor. Additionally, the VSEL0 ball of the converter is controlled by an OMAP GPIO (GPIO_WK7). This part may be found on sheet 2 of the schematics.

2.5 TWL6030 Power Companion IC

The TWL6030 device is a small (7 x 7 mm, 0.4mm pitch) 256 ball FBGA that provides many functions used on the Platform. Shown below is a feature list of the major functions/interfaces provided by the TWL6030 device that are utilized on the Panda platform. This list below doesn't include all device functionality, just that which is used on the Pandaboard ES.

- A power management system (FSM)
- 1 HS-I2C interface (≤ 2.4 Mbits/s) for all Phoenix Power IC GP control commands (CTL-I2C)
- 1 HS-I2C interface (≤ 2.4 Mbits/s) for all Smart-Reflex Class 3 control commands (SR-I2C)
- MMC card detection mechanism
- A 24MHz RC oscillator
- A 32kHz RC oscillator for a fast device start-up
- A high-performance crystal oscillator, for 32.768kHz external crystal
- A Real Time Clock (RTC) resource
- Power supply resources:
 - 11 Low Drop Out (LDO) regulators
 - 1 for internal purposes only (VRTC)
 - 1 for internal and platform needs (VANA)
 - 9 for platform needs (VAUX1, VAUX2, VAUX3, VCXIO, VDAC, VMMC, VPP, VUSB, VUSIM)
 - 7 buck SMPS with:
 - DVS capability Smart-Reflex Class 3 compatible (VCORE1, VCORE2, VCORE3)
 - 1 for I/O supply (V1V8), with specific PWMFORCE input control
 - 1 for LDOs pre-regulation (V2V1) and Phoenix Audio features
 - 1 for memory supply (VMEM)
 - 1 for external modem, RF transceiver or I/Os (V1V29)
- 3 general-purpose enables for possible platform upgrades (REGEN1, REGEN2, SYSEN)

2.5.1 TWL6030 Core SMPS Outputs

The TWL6030 implements three Switch Mode Power Supplies (SMPS) that source two of the three main core voltage rails for the OMAP4460 processor. The default voltage of all of these supplies is 0.95V, and each should be adjusted as required by S/W for the desired processor OPP.

VCORE1 is a 1200mA SMPS that is used to power the VDD_CORE balls on the OMAP4460 processor (net name VDD_VCORE3, (34 balls total) and the VDDA_DLLn_LPDDR21 and VDDA_DLLn_LPDDR22 balls, where n=0/1 (4 balls total). VCORE2 is a 600mA SMPS that is used to power the VDD_IVA_AUDIO balls on the processor (net name VDD_VCORE2, 10 balls total). VCORE3 is a 600mA SMPS that is not used on the OMAP4460 Pandaboard ES.

2.5.2 TWL6030 V1V8 SMPS Output

The TWL6030 V1V8 SMPS provides the I/O voltage for the Pandaboard ES (net name VIO_1v8). This is a 1200mA SMPS that provides a 1.8V output that is used to power many balls on the OMAP4460 processor that set the I/O voltage for the device. It also sources onboard peripherals that require an operating voltage referenced to processor I/Os.

2.5.3 TWL6030 V2V1 SMPS Output

The TWL6030 V2V1 SMPS output is used by the TWL6040 Audio Companion IC as an input for some of its internal power supplies (specifically the high side and low side LDOs and the negative charge pump). It is also connected to the TWL6030 as the input voltage to the VCXIO and VDAC LDOs (net name VDD_2V1). It is a 600mA SMPS with a default output value of 2.10V.

2.5.4 TWL6030 VMEM SMPS Output

The TWL6030 VMEM SMPS is not used on the OMAP4460 Pandaboard ES. The LPDDR2 power balls on the OMAP4460 that were previously connected to this rail for the OMAP4430 are connected to the V1V29 SMPS.

2.5.5 TWL6030 V1V29 SMPS Output

The TWL6030 V1V29 output is a 600mA SMPS used to provide the operating voltage for the VDD2 LPDDR2 balls on the OMAP4460 processor (net name VDD_VMEM). These OMAP balls are feed-throughs to the top POP footprint on the OMAP package, where they directly connect to the LPDDR2 VDD2 balls. This SMPS is a 600mA max capacity rail. The Micron LPDDR2 device used is an S4B type device, so VDD2 is required to be 1.2V. This is set in the TWL6030 companion chip by connecting the BOOT1 input to VRTC, which causes V1V29 to be set to a default of 1.225V.

2.5.6 TWL6030 LDO Power Resources

The VAUX2 LDO is a programmable LDO that is only connected to pin 1 of the LCD Expansion Connector J4. Its possible output voltage settings include 1.2V, 1.8V, 2.5V, 2.75V, and 2.8V, and its maximum output current is 200mA. The voltage to be programmed will be dependent on the board plugged into the LCD Expansion connectors, but will most likely be 2.8V.

The VAUX2 LDO is a programmable LDO that is only connected to pin 1 of the LCD Expansion Connector J4. Its possible output voltage settings include 1.2V, 1.8V, 2.5V, 2.75V, and 2.8V, and its maximum output current is 200mA. The voltage to be programmed will be dependent on the board plugged into the LCD Expansion connectors, but will most likely be 2.8V.

The VAUX3 LDO is a programmable LDO that is only connected to pin 30 of the Camera Expansion Connector, J17. Its possible output voltage settings include 1.0V, 1.2V, 1.3V, 1.8V, 2.5V, 2.8V, 3.0V, and its maximum output current is 200mA. The output voltage to be utilized would depend on the implementation of the camera module.

The VCXIO LDO is a fixed 1.8V, 200mA LDO that provides a 1.8V input to certain noise sensitive OMAP4460 balls. The balls powered by this LDO include the VDDA_CSI2 balls (V28 and W28), the VDDA_DPLL balls (G13, P9 and Y16), and on this revision of the Pandaboard ES, the VDDS_DV_BANK7 ball (M28). This LDO also provides power for the onboard 38.4 MHz oscillator.

The VDAC LDO is a fixed 1.8V, 50mA LDO that provides a 1.8V input to certain noise sensitive OMAP4460 balls. The balls powered by this LDO include the VDDA_HDMI_VDAC balls (A11 and G12).

The VMMC LDO is a programmable LDO that provides the voltage to the VDDS_MMC1 balls on the OMAP processor (pins G7 and H7) as well as the SDMMC cardcage. This LDO is off when the board is powered on, but is turned on and set to 1.8V or 3.0V depending on card capabilities detected.

The VRTC LDO is an adjustable LDO that provides internal voltages to the TWL6030 device. Its possible output voltage settings are 1.8V and 2.5V and its maximum output current is 25mA. In normal operation, it should always be set to 1.8V.

The VUSB LDO is a fixed 3.3V, 35mA LDO that provides voltage to the OMAP4460 that it uses for its internal USB transceiver. The only ball powered by this LDO is the VDDA_USBA00TG_3P3V ball (ball A5).

The VPP LDO is adjustable LDO that powers the VPP_CUST and VPP_STD balls on OMAP (balls J8 and Y22). This LDO is only needed for eFuse operations and can be left disabled for normal Pandaboard ES operation.

2.5.7 TWL6030 Clock Circuitry

The TWL6030 has an 32.768 KHz crystal connected across its OSC32KIN and OSC32KOUT balls. This crystal is used by the TWL6030 to generate three output 32.768 KHz, 1.8V square wave clock outputs. These outputs are:

CLK32KAO: always on clock connected to the SYS32K input of the OMAP4460 processor.

CLK32KAUDIO: clock connected to the CLK32K input of the TWL6040 Audio Companion IC.

CLK32KG: a gated 32.768 clock connected to the SLOW_CLK input of the LS Research module. This clock will be off by default at reset, and must be enabled by software.

2.6 TWL6040 Audio Companion IC

The TWL6040 device is a small (6 x 6 mm, 0.5mm pitch) 120 ball PBGA that provides many functions, primarily audio, used on the Platform. Shown below is a feature list of the major functions/interfaces provided by the TWL6040 device.

- A audio management system
 - PDM Interface for Audio and control
 - Analog Microphone Interface
 - Headset – speaker (32 ohm) and microphone
 - Earpiece Output
 - Aux Output
 - Hands-free 8 ohm driver
 - Dual Vibrator
- Misc Control
 - GPO
 - I2C (high speed)
 - Power on/off
- Power
 - Internal LDOs
 - Internal negative charge pump

2.7 SYSBOOT Configuration

The OMAP4460 Processor has eight SYSBOOT inputs. These inputs are sampled after a board reset, and determine the booting and operating mode of the OMAP4460 Processor. The upper two inputs (SYSBOOT[7:6]) control the clocking modes of the part (i.e. enabling/disabling the internal oscillator to allow using a crystal input or oscillator). They are currently set to “11” and should not be changed.

The lower six inputs, SYSBOOT[5:0] determine the type and order of memory or peripheral booting. SYSBOOT[5] determines whether memory or peripheral booting is preferred. The SYSBOOT definitions may be found in the OMAP4460 TRM, but are included here for convenience. See Table 2 on page 24 for the SYSBOOT definitions for peripheral preferred booting, and Table 3 on page 25 for memory preferred booting SYSBOOT definitions. The shaded row(s) in Table 2 are the default configuration of the Pandaboard ES, depending on the setting of SW1.

If it is desired to change the SYSBOOT configuration, resistors may be added or removed from the SYSBOOT[5:0] lines (except for SYSBOOT3, which may be changed by changing the position of switch SW1). The SYSBOOT[5:0] lines have weak internal pull-down resistors inside the OMAP4460, so removing the onboard resistor will result in the line being sampled as a ‘0’ at reset, and installing a 3.3K

or lower value resistor will result in the line being sampled as a '1' at reset. See Figure 3 on page 23 for the location of the resistors on SYSBOOT[5:0]. These resistors are connected to OMAP4460 as follows:

- SYSBOOT0: R123
- SYSBOOT1: R138
- SYSBOOT2: R128
- SYSBOOT3: N/A (controlled by switch SW1)
- SYSBOOT4: R137
- SYSBOOT5: R139

NOTE: Do not use pull-up resistance values higher than 3.3Kohm on the SYSBOOT lines. This would create a voltage divider with the internal OMAP pulldown, potentially causing an invalid value to be internally latched for SYSBOOT.

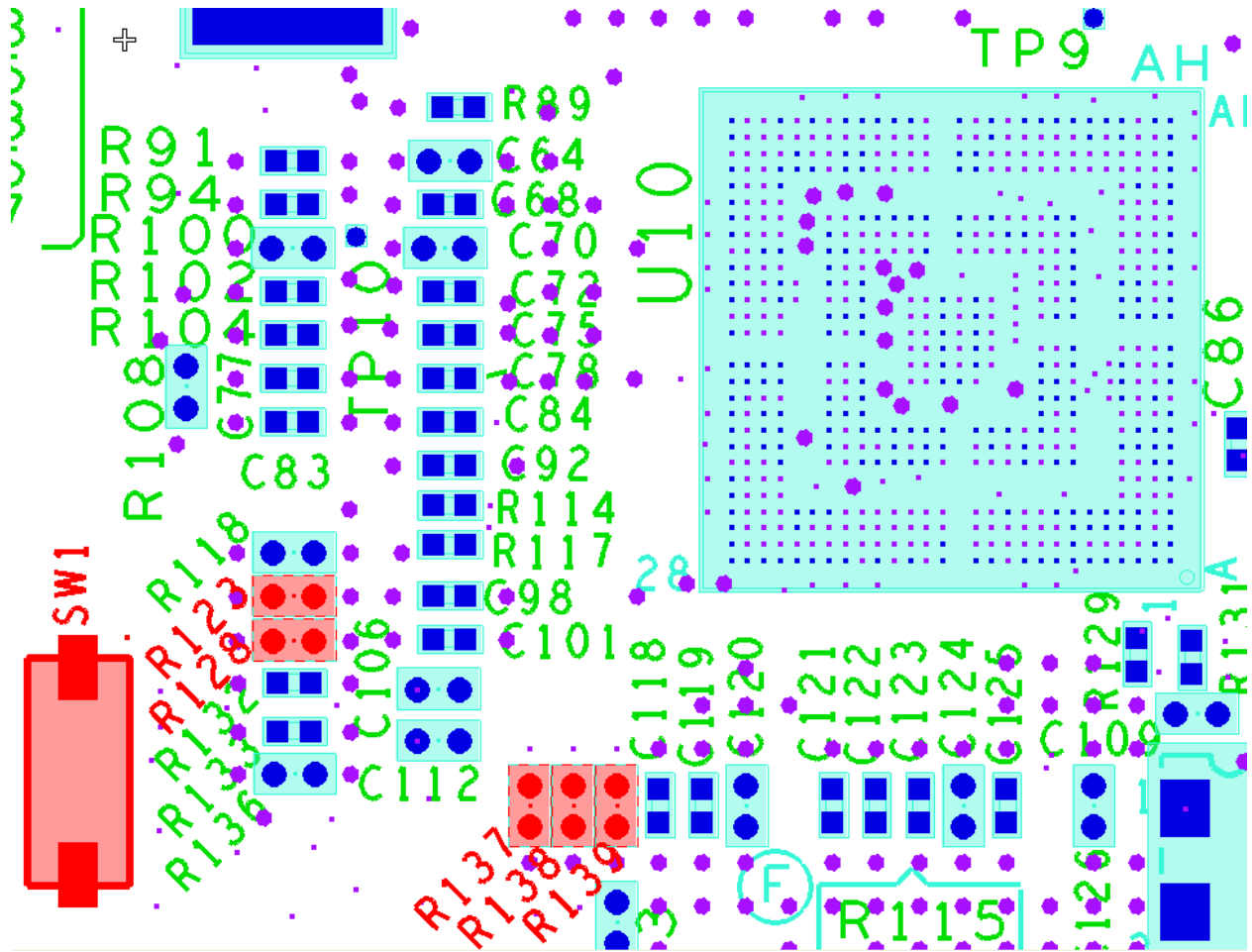

Figure 3 – SYSBOOT[5:0] Resistor Locations + SYSBOOT3 Switch Location



SYSBOOT[5:0]	Booting Devices Order			
	1 st	2 nd	3 rd	4 th
000000	USB	MMC2(1)		
000001	USB	XIP		
000010	USB	XIPWAIT		
000011	USB	NAND		
000100	USB	EMIF		
000101	USB	MMC1		
000110	USB	OneNAND		
000111	USB	OneNAND	MMC2(1)	
001000	UART	MMC2(1)		
001001	UART	XIP		
001010	UART	XIPWAIT		
001011	UART	NAND		
001100	UART	EMIF		
001101	UART	MMC1		
001110	UART	OneNAND		
001111	USB-ULPI	MMC2(1)		
010000	USB-ULPI	XIP		
010001	USB-ULPI	XIPWAIT		
010010	USB-ULPI	NAND		
010011	USB-ULPI	EMIF		
010100	USB-ULPI	MMC1		
010101	USB-ULPI	OneNAND		
010110	USB	UART	MMC1	MMC2(1)
010111	USB	UART	MMC1	XIP
011000	USB-ULPI	UART	MMC2(2)	
011001	USB	UART	MMC1	NAND
011010	UART	MMC2(2)		
011011	USB	UART	MMC1	
011100	USB	MMC2(2)		
011101	Reserved			
011110	Reserved			
011111 ⁽¹⁾	Fast XIP booting. Wait monitoring off	USB	USB	UART

⁽¹⁾ Only on GP devices

Table 2: SYSBOOT[5:0] Definitions – Peripheral Preferred Booting

SYSBOOT[5:0]	Booting Devices Order			
	1 st	2 nd	3 rd	4 th
100000	MMC2(1)	USB		
100001	XIP	USB		
100010	XIPWAIT	USB		
100011	NAND	USB		
100100	EMIF	USB		
100101	MMC1	USB		
100110	OneNAND	USB		
100111	OneNAND	MMC2(1)	USB	
101000	MMC2(1)	UART		
101001	XIP	UART		
101010	XIPWAIT	UART		
101011	NAND	UART		
101100	EMIF	UART		
101101	MMC1	UART		
101110	OneNAND	UART		
101111	MMC2(1)	USB-ULPI		
110000	XIP	USB-ULPI		
110001	XIPWAIT	USB-ULPI		
110010	NAND	USB-ULPI		
110011	EMIF	USB-ULPI		
110100	MMC1	USB-ULPI		
110101	OneNAND	USB-ULPI		
110110	MMC2(1)	USB	UART	MMC1
110111	XIP	USB	UART	MMC1
111000	MMC2(2)	USB-ULPI	UART	
111001	NAND	USB	UART	MMC1
111010	MMC2(2)	UART		
111011	MMC1	USB	UART	
111100	MMC2(2)	USB		
111101	Reserved			
111110	Reserved			
111111 ⁽¹⁾	Fast XIP booting. Wait monitoring off	USB	UART	

⁽¹⁾ Only on GP devices

Table 3: SYSBOOT[5:0] Definitions – Memory Preferred Booting

2.8 Miscellaneous Power Circuitry

2.8.1 Input Power Circuitry

The input power circuitry may be found on sheet 2 of the board schematic. A block diagram of this circuitry is shown in Figure 4 below. The Pandaboard ES may be run either with or without a DC wall supply plugged into the input power jack at P3.

Without an external power supply plugged in, the 5Vdc input power is supplied from the mini-AB USBOTG connector at J18. This supply is only capable of providing 500mA of output current (1A if operating via a USB cable with a “Y” connection to the host), so board operations will be limited in this mode (e.g. operations could be limited, depending on current requirements). The path of current flow in this mode is designated below by the red arrow. The 5V from VBUS will be routed through the switch at U21, to the TPS54320 switching power supply at U22, which provides a 3.7V “battery” voltage for the TWL6030 and TWL6040 Companion ICs.

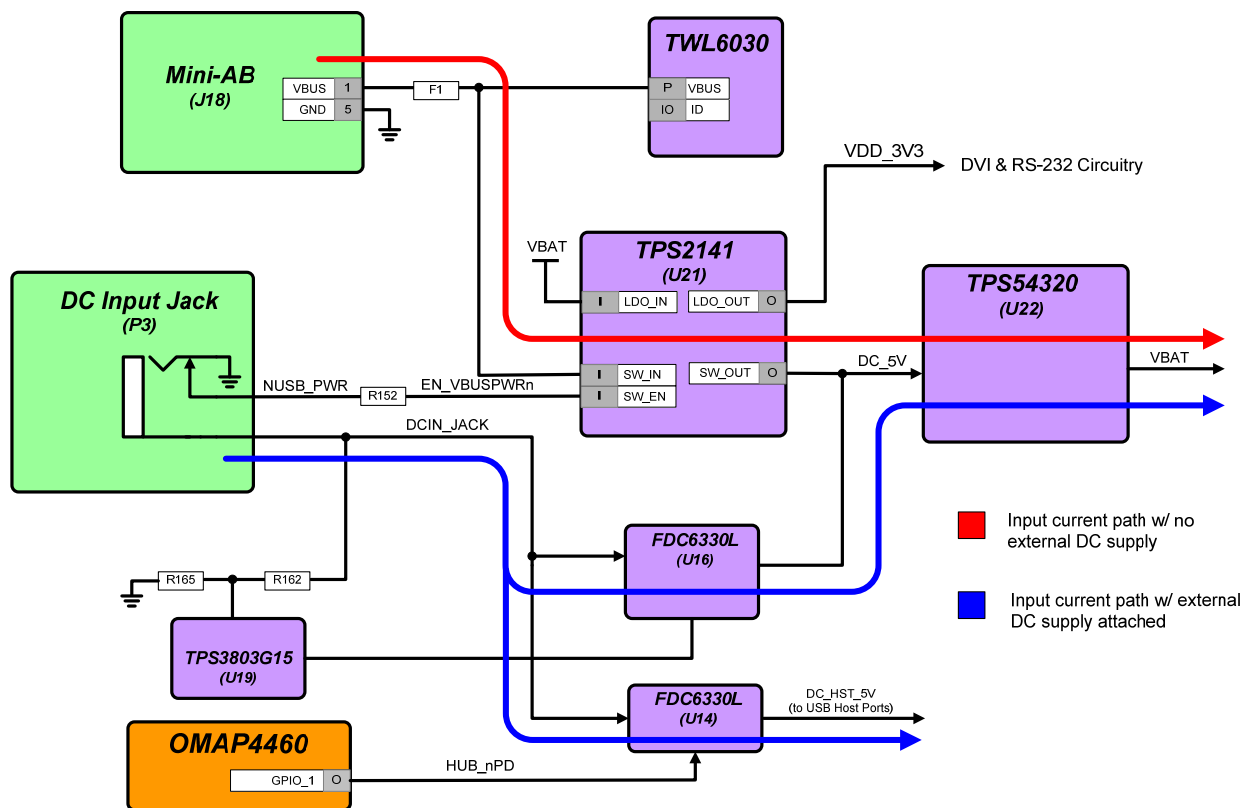

Figure 4 – Pandaboard ES Input Power Circuitry Block Diagram

With an external power supply plugged in, the 5Vdc input power is supplied from the input DC jack at P3. The current capability in this mode is only limited by the particular DC supply being used. The path of current flow in this mode is designated below by the blue arrows. The switch at U21 will be disabled by the insertion of the DC input jack in this mode, and the regulated 5Vdc from the wall supply will be connected to the input of the TPS54320 switching power supply at U22, which provides a 3.7V “battery” voltage for the TWL6030 and TWL6040 Companion ICs.

CAUTION: only use a 5Vdc regulated power supply to power the Pandaboard ES. Connecting a supply with an output higher than +5Vdc could cause possible board damage.

The supervisor IC at U19 has the DC input power tied to its VDD pin through a voltage divider. When the voltage at the VDD input of this IC exceeds 1.40V (i.e. DCIN_JACK \geq 5.64V), the reset output of the supervisor is negated. This will enable the two FETs at T1A and T1B, which will illuminate the red overvoltage indicator, and disable the load switch at U16, which removes input power to the onboard circuitry. The load switch at U14 that provides 5V USB Host power is enabled and disabled manually by writing GPIO_1 to a ‘1’, or a ‘0’, respectively. This load switch powers up disabled.

2.8.2 USB/Ethernet Power Circuitry

There is a fixed 3.3V LDO (U11) that provides power for the LAN9514 Ethernet/USB Hub device. This device is a Texas Instruments TPS73633DBVR device which can provide up to 400mA of output current. This device may be controlled via S/W by writing OMAP4460 GPIO_1. Writing this GPIO high will enable this LDO, while writing it low will disable it (see Table 10 on page 41). This device is shown on sheet 11 of the schematic.

2.9 Standard Volatile Memory

The OMAP4460 processor supports two LPDDR2 channels, accessible only via a POP memory device soldered on the 216-ball, 12x12 mm footprint on top of the OMAP4460 processor. Each channel supports up to two chip-selects, so up to four LPDDR2 memory dies are supported. The two stacked memory packages are directly connected to the two LPDDR2 EMIF4D interfaces of the OMAP4460 die. The base address for the LPDDR2 is 0x8000 0000.

An 8Gb/1GB POP LPDDR2 DRAM device (Elpida P/N EDB8064B1PB-8D-F) is provided on the Pandaboard ES. The memory device has four dies, with each die being a separate 2Gb LPDDR2.

2.10 Debug UART Interface

A single RS-232 port is provided on the Pandaboard ES via 9-pin D-sub female connector at location P4. It provides access to the UART3 interface of the OMAP4460. See Figure 5 for the implementation of the RS232 port.

The TXS0104EZXR device at U20 is a voltage translator that translates between the 1.8V logic levels required by the OMAP4460 processor to the 3.3V logic levels required by the SN75C3232EDR. The SN75C3232EDR @ U23 is an RS-232 transceiver that converts the 3.3V logic signals to/from the voltage translator to the RS-232 signal levels required (-5V to +5V).

The UART port at P4 can be accessed by using Teraterm or other terminal emulation program. To use this UART interface, the serial port settings should be applied as follows:

- BAUD RATE: 115200
- DATA: 8 bit
- PARITY: none
- STOP: 1bit
- FLOW CONTROL: none

This port requires the use of a 9-pin D-sub Male to Female cable.

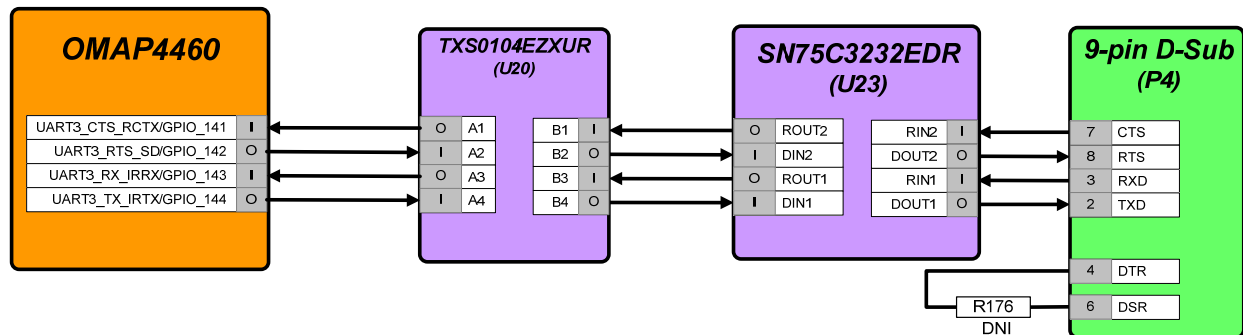

Figure 5 – Panda UART3/RS-232 Block Diagram

2.11 SD/MMC Connector

The OMAP4460 Pandaboard ES supports removable memory storage via onboard SD/MMC card cage. It is an eight-bit card cage that supports 1.8V or 3.0V cards. Card detect functionality is supported via the TWL6030 power companion IC. See Figure 6 for a block diagram of the interface signaling to the card cage. The resistors shown in Figure 6 below are 33 ohm series termination resistors.

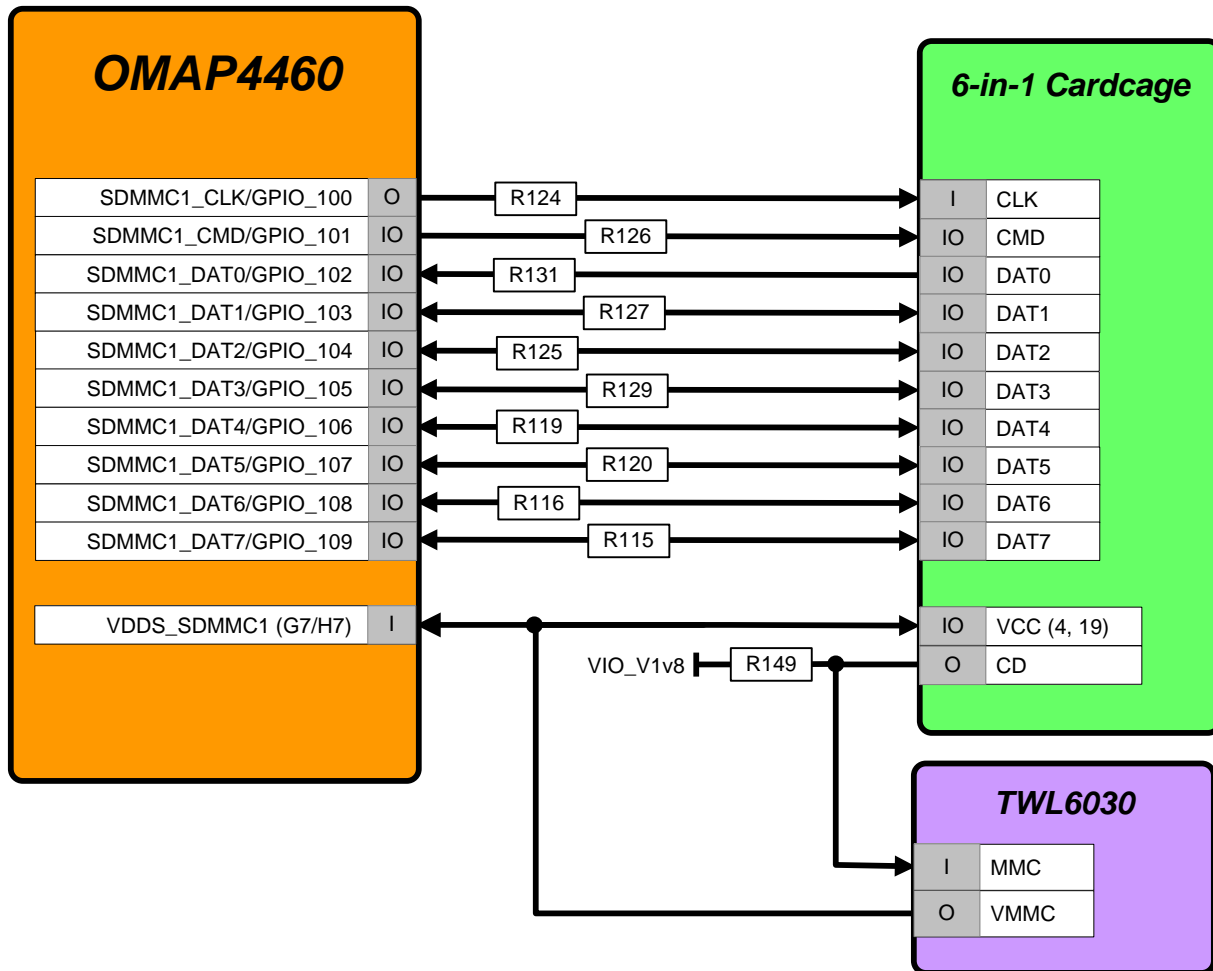

Figure 6 – Panda SDMMC1 Card Cage Block Diagram

2.12 HDMI Interface

The OMAP4460 Pandaboard ES provides a High-Definition Multimedia Interface (HDMI) via an industry-standard Type A connector at location P2. The interface is provided using the internal HDMI module provided by the OMAP4460. See Figure 7 for a block diagram of the Pandaboard ES HDMI circuitry. This interface includes a Texas Instruments TPD12S015A HDMI Port Protection/Interface device. The high-speed differential clock and data lines are connected straight from OMAP to the ESD protection device, to the connector, so that any ESD event experienced at the connector will be absorbed before damaging the OMAP4460 device I/Os.

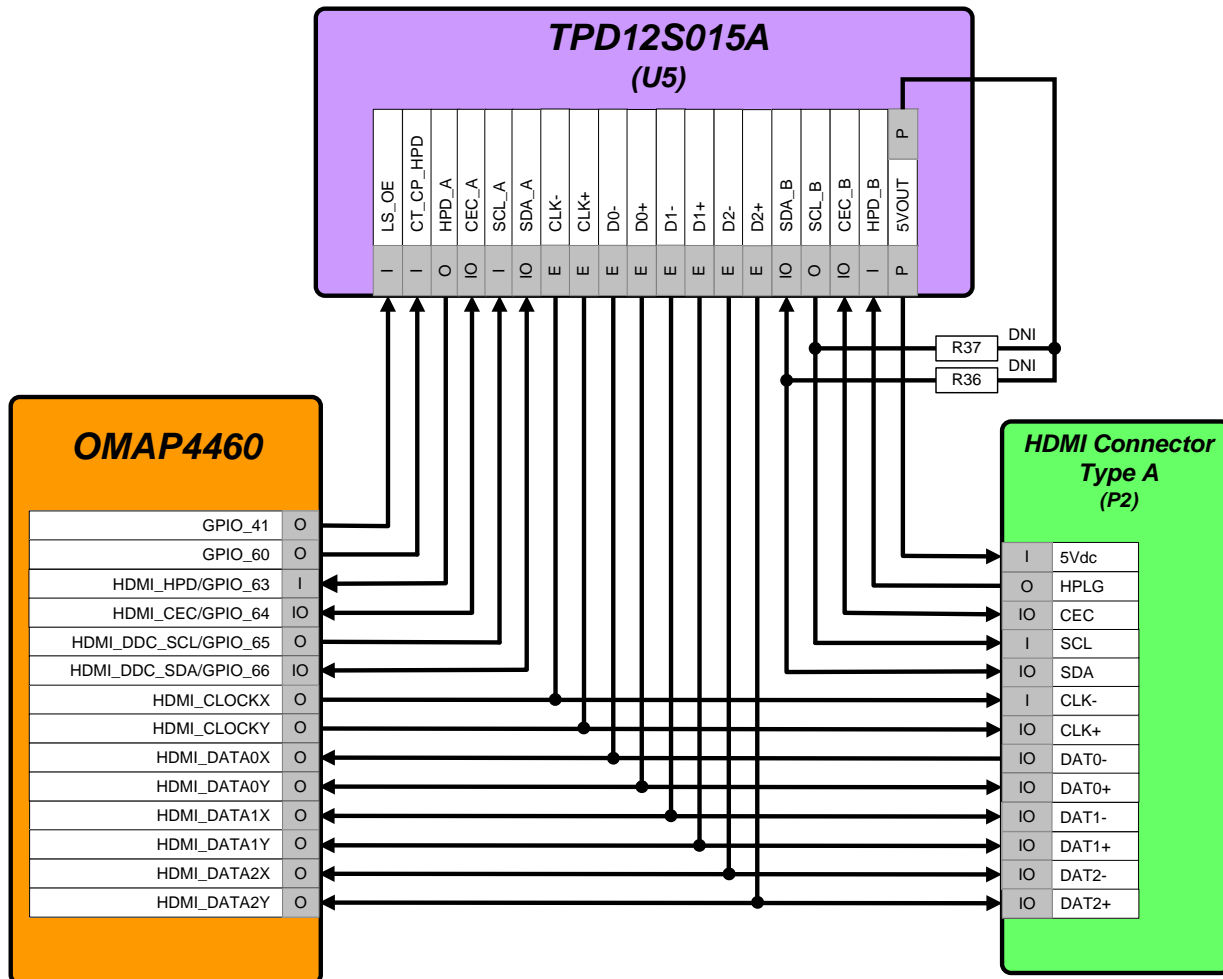

Figure 7 – Panda HDMI Interface Block Diagram

In addition to providing ESD protection on the signals coming from the connector, this device performs voltage translation on the control signals in the HDMI interface (SCL, SDA, CEC, and HPD) from the 1.8V levels of the OMAP4460 to the 5V levels required by a TV set. It also implements a DC/DC boost converter that operates from the “battery” voltage, VBAT, and outputs a 5Vdc output that is capable of sourcing up to 55mA of current. See Table 4 for the GPIOs used on the HDMI interface and a description of their function. The direction column in this table indicates whether this device is an output from OMAP (O) or an input to OMAP (I).

GPIO	Dir	Signal Name	Description
GPIO_41	O	HDMI_LS_OE	TPD12S015A Level Shifter and internal LDO Enable 1 = Enabled, 0 = Disabled
GPIO_60	O	HDMI_CT_CP_HPD	TPD12S015A DC/DC Converter and Hot-Plug Detect Enable 1 = Enabled, 0 = Disabled

Table 4: HDMI GPIO Definitions

2.13 Display Interface

The Pandaboard ES provides two possible options for the usage of the OMAP4460 parallel display signals. The first option is to use the onboard TFP410 DVI transmitter, whose output feeds an onboard DVI-D connector. The second option is to use a Display Board plugged into a pair of 20-pin LCD expansion connectors (J1 and J4). Both of these possible options are discussed in the following paragraphs. Additionally, a third display option has been added to the OMAP4460 Pandaboard ES. This option is using a DSI Display Board plugged into connector J7 on the back side of the PCB. See Figure 8 for a diagram of the Pandaboard ES Display Interface options.

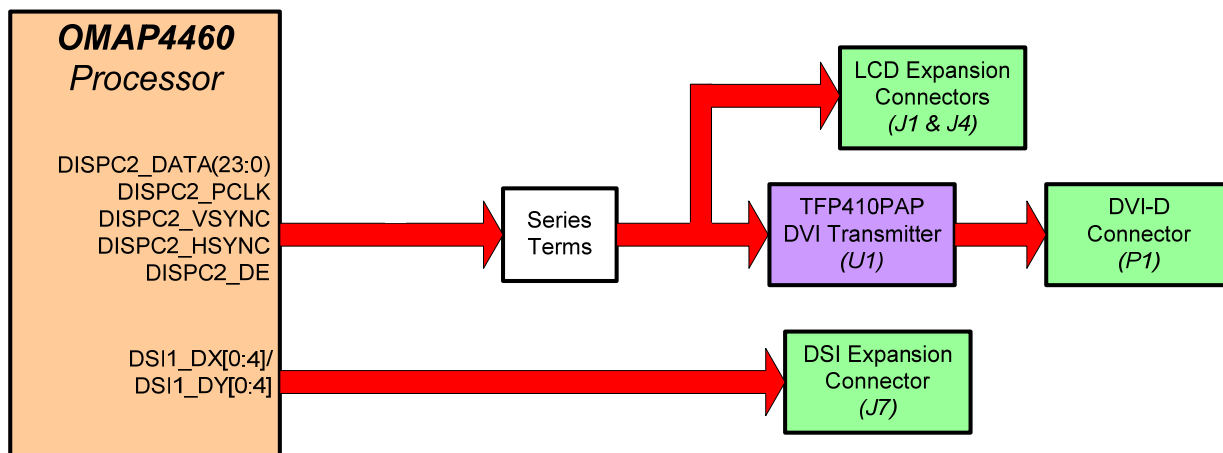

Figure 8 – Panda Display Interface Block Diagram



2.13.1 Parallel Display Interface

See Figure 9 for a detailed block diagram of the OMAP4460 Pandaboard ES parallel display interface. (NOTE: J1/J4 are pin-compatible with the OMAP3530 BeagleBoard, so display boards designed for it may be used with the OMAP4460 Pandaboard ES).

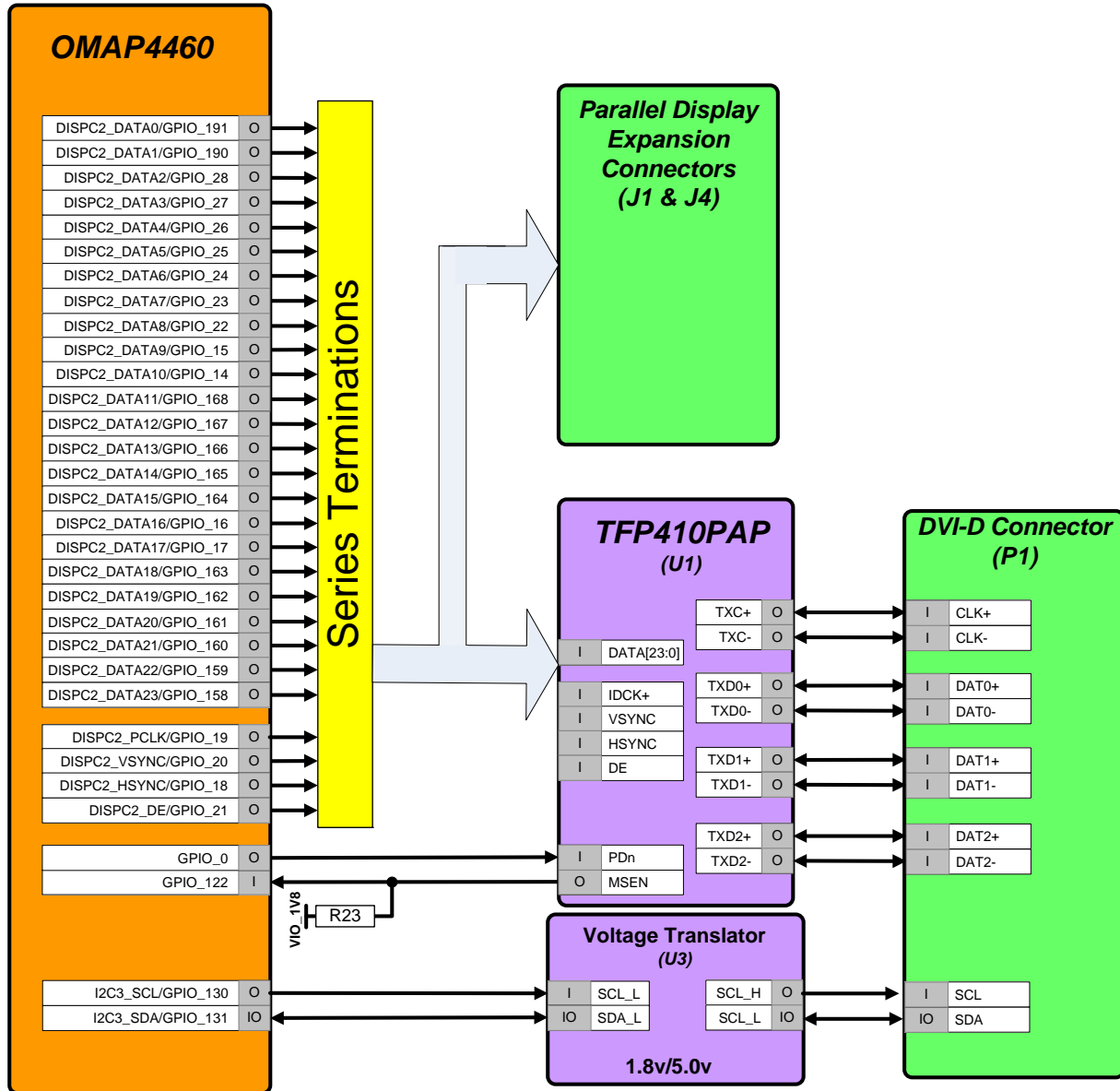

Figure 9 – Pandaboard ES DSS Output Block Diagram



See Table 5 for the GPIOs used on the Parallel display interface and a description of their function. This table does not include the 28 parallel display signals (DATA[23:0], PCLK, VSYNC, HSYNC, and DE).

NOTE: no configuration changes are required to switch between usage of the onboard DVI connector or an external display plugged into the display expansion connectors.

GPIO	Signal Name	Description
GPIO_0	H_GPIO_0/ TFP410_NPD	TFP410 Device Power down (<i>note: this GPIO goes through a voltage translator to meet the 3.3V I/O requirement of the TFP410 on this pin</i>) 1 = Normal Operation, 0 = Power Down
GPIO_122	DVI_MSEN	TFP410 Monitor Sense 0 = Powered on receiver sensed at the differential outputs 1 = No powered on receiver detected. (<i>note: this output from the TFP410 is open-drain and has a pull-up to 1.8V, so it is connected directly to OMAP</i>)

Table 5: DVI-D Display GPIO Definitions

See Table 6 and Table 7 for the pinout of the display expansion connectors.

Pin#	Signal	I/O	Description
1	DCIN JACK	PWR	DC rail from the Main DC supply
2	DCIN JACK	PWR	DC rail from the Main DC supply
3	h_DSS_DAT1	I	LCD Pixel Data bit 1
4	h_DSS_DAT0	I	LCD Pixel Data bit 0
5	h_DSS_DAT3	I	LCD Pixel Data bit 3
6	h_DSS_DAT2	I	LCD Pixel Data bit 2
7	h_DSS_DAT5	I	LCD Pixel Data bit 5
8	h_DSS_DAT4	I	LCD Pixel Data bit 4
9	h_DSS_DAT12	I	LCD Pixel Data bit 12
10	h_DSS_DAT10	I	LCD Pixel Data bit 10
11	h_DSS_DAT23	I	LCD Pixel Data bit 23
12	h_DSS_DAT14	I	LCD Pixel Data bit 14
13	h_DSS_DAT19	I	LCD Pixel Data bit 19
14	h_DSS_DAT22	I	LCD Pixel Data bit 22
15	H_I2C2_SDA	I/O	I2C2 Serial Data
16	h_DSS_DAT11	I	LCD Pixel Data bit 11
17	h_DSS_VSYNC	I	LCD Vertical Sync Signal
18	H_DPM_EMU2	I	DPM_EMU2/GPIO_13
19	GND	PWR	Ground bus
20	GND	PWR	Ground bus

Table 6: LCD Expansion Connector “A” Pin Definitions (J1)

Pin#	Signal	I/O	Description
1	VDD_VAUX2	PWR	Power rail (adjustable from 1.2V to 2.8V)
2	VIO_1V8	PWR	1.8V system I/O voltage
3	h_DSS_DAT20	I	LCD Pixel Data bit 20
4	h_DSS_DAT21	I	LCD Pixel Data bit 21
5	h_DSS_DAT17	I	LCD Pixel Data bit 17
6	h_DSS_DAT18	I	LCD Pixel Data bit 18
7	h_DSS_DAT15	I	LCD Pixel Data bit 15
8	h_DSS_DAT16	I	LCD Pixel Data bit 16
9	h_DSS_DAT7	I	LCD Pixel Data bit 7
10	h_DSS_DAT13	I	LCD Pixel Data bit 13
11	h_DSS_DAT8	I	LCD Pixel Data bit 8
12	NUSB_PWR	O	Input Power Enable
13	h_DSS_DAT9	I	LCD Pixel Data bit 9
14	H_I2C2_SCL	I	I2C2 Serial Clock
15	h_DSS_DAT6	I	LCD Pixel Data bit 6
16	h_DSS_PCLK	I	LCD Pixel Clock
17	h_DSS_DEN	I	LCD Data Enable
18	h_DSS_HSYNC	I	LCD Horizontal Sync
19	GND	PWR	Ground bus
20	GND	PWR	Ground bus

Table 7: LCD Expansion Connector “B” Pin Definitions (J4)

2.13.2 DSI Display Expansion Connector Interface

A third display option for the Pandaboard ES is to plug an external display module into the DSI display expansion connector J7. This connector is a 40-pin, 0.8mm pitch connector (Hirose P/N FX6A-40P-0.8SV91), and is mounted on the back side of the Pandaboard ES PCB. See Figure 10 below for the orientation/pin numbering of this connector as viewed from the back side of the PCB.

A block diagram of the Pandaboard ES Display Expansion interface is shown in Figure 11 on page 36.

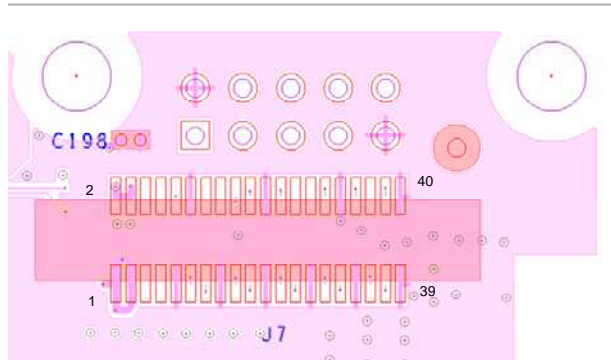

Figure 10 – Panda DSI Display Connector Orientation

See Table 8 for the pinout of J7 and a description of the signals on the connector. Any pin not shown in Table 8 is not connected.

J7 Pin #	OMAP Ball #	Signal Name	Signal Description
1,3	---	VIO_1V8	VIO from TWL6030
2,4	---	VBAT	Battery input voltage
Multiple	---	DGND	Signal Ground (connected on pins 9, 12, 15, 21, 22, 27, 32, 33, 39, and 40)
10	---	PHO_PWM1	PWM1 output of TWL6030 device
11	P3	DSI1_DX0	DSI Signal Lane 0 Data X
13	P4	DSI1_DY0	DSI Signal Lane 0 Data Y
17	N3	DSI1_DX1	DSI Signal Lane 1 Data X
18	C26	h_I2C2_SCL	I ² C Clock In
19	N4	DSI1_DY1	DSI Signal Lane 1 Data Y
20	D26	h_I2C2_SDA	I ² C Data I/O
23	M3	DSI1_DX2	DSI Signal Lane 2 Data X
24	D21	TSC_nINT	Touchscreen Interrupt Out (GPIO_52)
25	M4	DSI1_DY2	DSI Signal Lane 2 Data Y
29	L3	DSI1_DX3	DSI Signal Lane 3 Data X
30	AG24	h_DMTIMER11_PWM	Display PWM (GPIO_121)
31	L4	DSI1_DY3	DSI Signal Lane 3 Data Y
34	B24	h_GPIO_102	LCD Reset (GPIO_102)
35	K3	DSI1_DX4	DSI Signal Lane 4 Data X
37	K4	DSI1_DY4	DSI Signal Lane 4 Data Y
38	A24	H_DSI1_TE0	Display Tearing Effect (GPIO_101)

Table 8: DSI Display Expansion Connector Pin Definitions (J7)

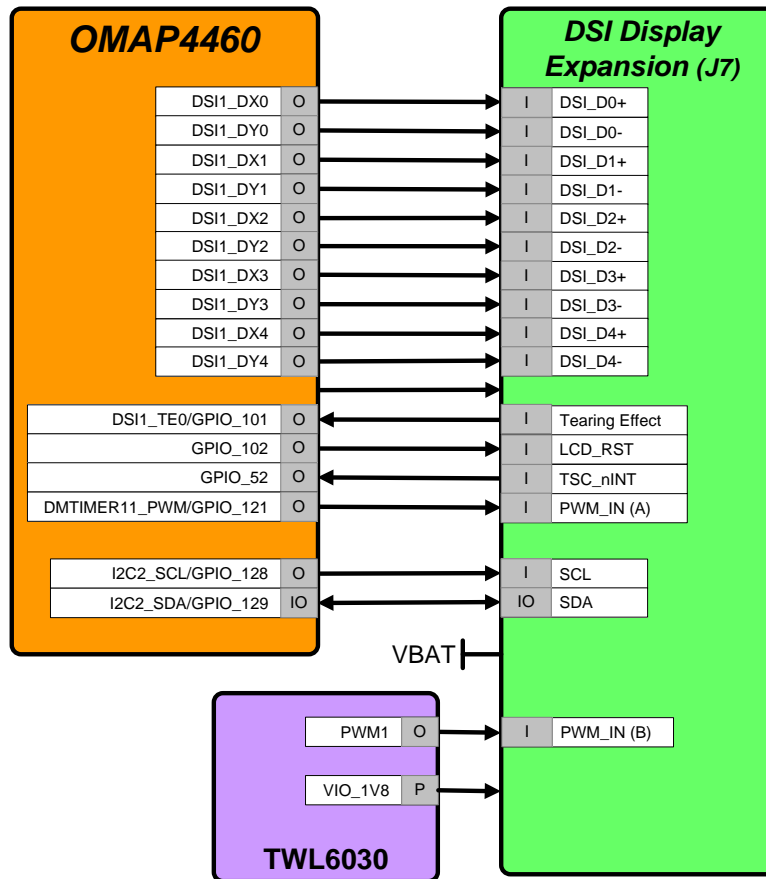

Figure 11 – Panda DSI Display Expansion Block Diagram

2.14 Bluetooth/WLAN Interfaces

The Pandaboard ES provides a module (LS Research Inc. P/N TiWi-BLE) that provides a Bluetooth interface, and a 2.4 GHz 802.11b/g/n interface. This module may be found on sheet 14 of the schematics (reference designator U3). It uses Texas Instruments' WiLink™ 6.0 solution. Information for this module may be found at: <http://www.lsr.com>.

See Figure 12 for a diagram of the Pandaboard ES connectivity to this module. See Table 9 on page 38 for a description of the GPIOs used to interface to the module and their function.



The OMAP4460 interfaces are connected to the LS Research WiLink™ module as follows:

- SDMMC5: WLAN SDIO interface
- UART2: Bluetooth Host Control Interface
- McBSP1: Audio Digital PCM Path

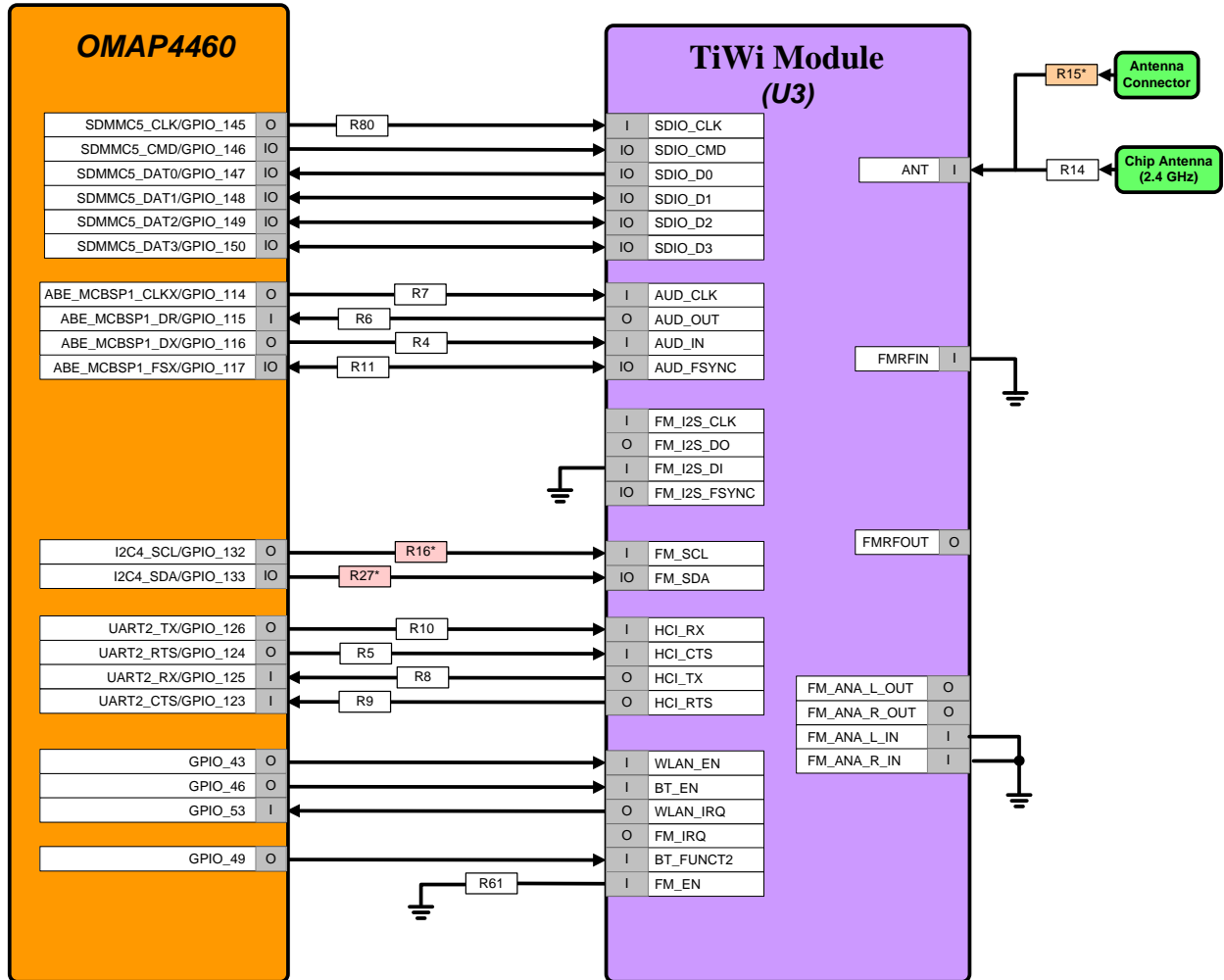

Figure 12 – Pandaboard ES WLAN/Bluetooth Interface Block Diagram



GPIO	Dir.	Signal Name	Description
GPIO_43	O	WLAN_EN	802.11b/g Enable 1 = Enabled, 0 = Disabled
GPIO_46	O	BT_EN	Bluetooth Enable 1 = Enabled, 0 = Disabled
GPIO_49	I	BT_WAKEUP	Bluetooth Wakeup
GPIO_53	I	WLAN_nIRQ	WLAN Interrupt Input

Table 9: WLAN/Bluetooth Module GPIO Definitions

2.15 Audio Interfaces

See Figure 13 for a block diagram of the audio connectivity on the OMAP4460 Pandaboard ES. In this block diagram, the signals with a red background in the box specifying their direction are analog I/Os while all others are 1.8V digital I/Os.

The OMAP4460 Pandaboard ES provides a stacked audio connector, which provides two 3.5mm audio jack connections. The upper jack on this stacked connector (J16A in Figure 13 below), is connected to FM Audio Left and Right inputs of the TWL6040 Audio Companion IC (AFML/AFMR). The lower jack on this stacked connector (J16B in Figure 13 below) is connected to the Headset Right and Left outputs of the TWL6040. Additionally, there is a 2nd possible connection to the TWL6040 Auxiliary outputs (AUXLP/AUXRP). To enable this alternate path, resistors R181 and R182 would need to be removed, and zero ohm, 0402 resistors should be installed at locations R160 and R164.

The digital path for this audio back to the OMAP4460 processor is through the PDM interface. For expansion purposes, the left Hands-Free speaker outputs of the TWL6040 are connected to the Expansion Connector J6 (see Paragraph 2.17 on page 41 for further details).

The Pandaboard ES also provisions a digital PCM path for Bluetooth audio from the module to OMAP4460 via McBSP1.

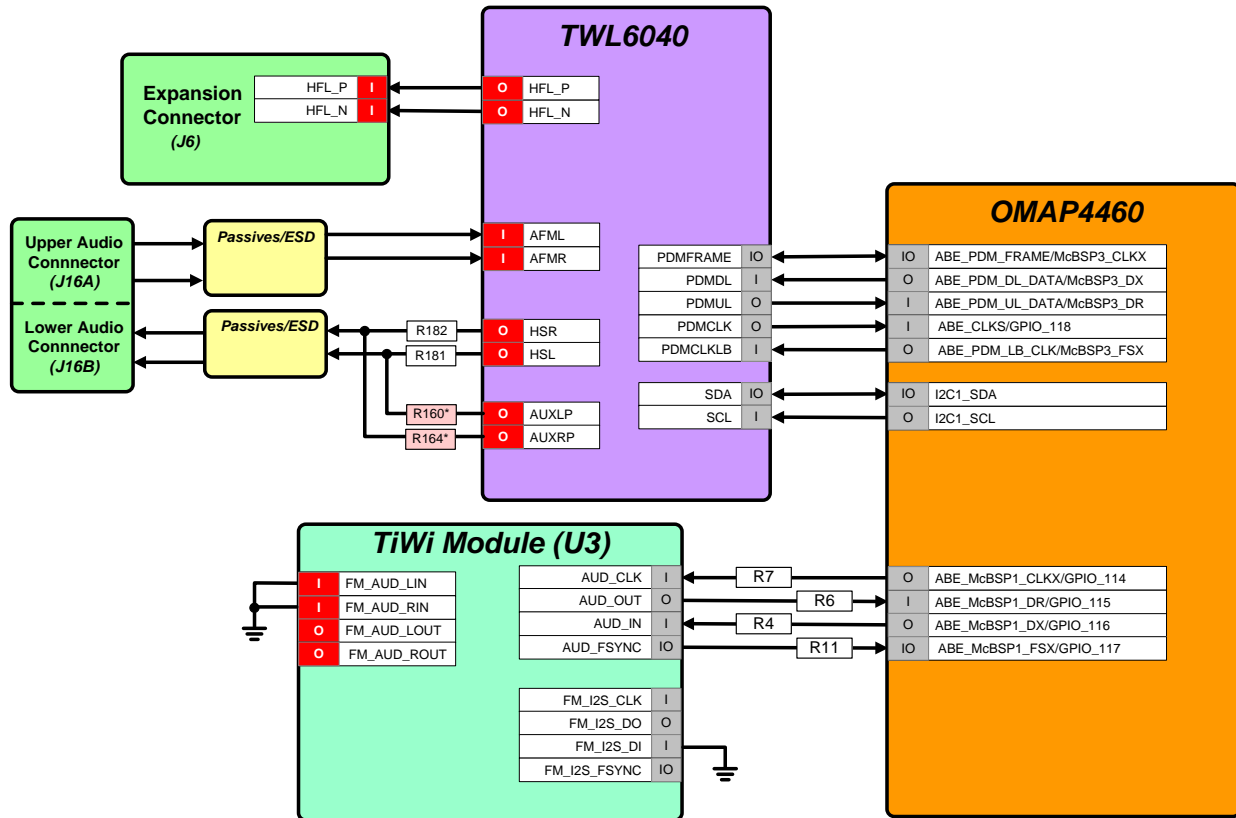

Figure 13 – Panda Audio Interface Block Diagram

2.16 USB Interfaces

The Pandaboard ES utilizes two USB interfaces. The first is a DP/DM interface from the internal transceiver within OMAP to the mini-AB connector J18. The second interface utilizes the 12-wire ULPI interface (USBB1) to an onboard USB phy, whose DP/DM I/Os are interfaced to a Hub IC which provides four downstream USB Host ports, and an Ethernet interface. Each of these interfaces will be discussed in more detail in the following paragraphs.

2.16.1 USBOTG Interface

The Pandaboard ES uses the USB OTG transceiver within the OMAP4460 that is connected to an industry-standard mini-AB connector (J18) as shown in Figure 14. The VBUS from the connector is connected to the TWL6030 companion Power IC, which can provide up to 100mA in host mode (i.e. when a client device is connected). The Pandaboard ES may only be used in host mode if a +5Vdc power supply is installed in power jack P3.

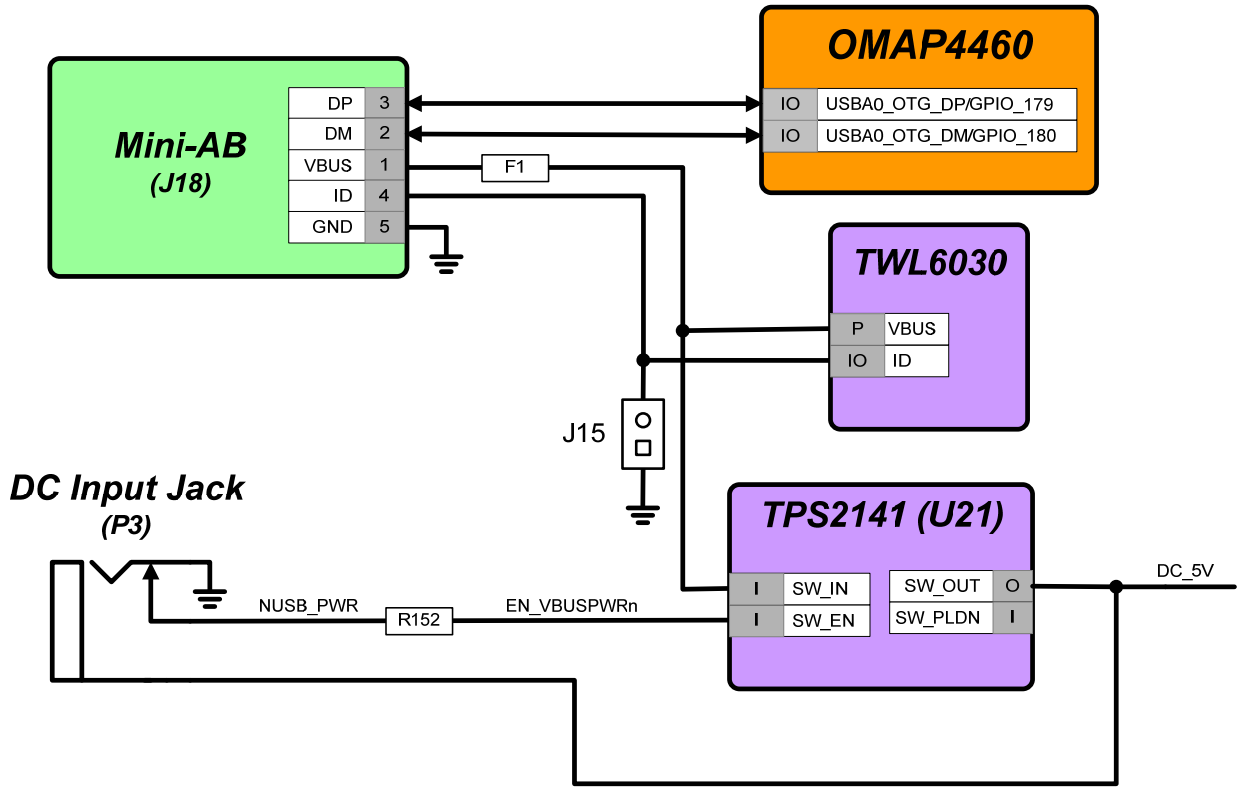

Figure 14 – Panda USBOTG Interface Block Diagram

2.16.2 USBB1 Phy Interface

The Pandaboard ES uses the 12-wire OMAP4460 USBB1 ULPI interface connected to an SMSC USB3320C-EZK phy. This Phy converts the 12-wire ULPI interface to a DP/DM pair that is used as the upstream USB interface to the LAN9514 USB/Ethernet Hub IC. The Hub IC provides four downstream Host USB ports, and an Ethernet interface. Two of the USB Host Ports are available via the combo connector J9, while the other two ports are available via Expansion Connector J6. The Ethernet interface is available via a tab-up RJ-45 connector at J9. See Figure 15 for a block diagram of the Pandaboard ES USBB1 interface connectivity.

- *Note that the reference clock to the USB3320C is sourced from the FREF_CLK3_OUT output of OMAP4460, and this OMAP output must be programmed for a clock frequency of 19.2 MHz for proper operation*



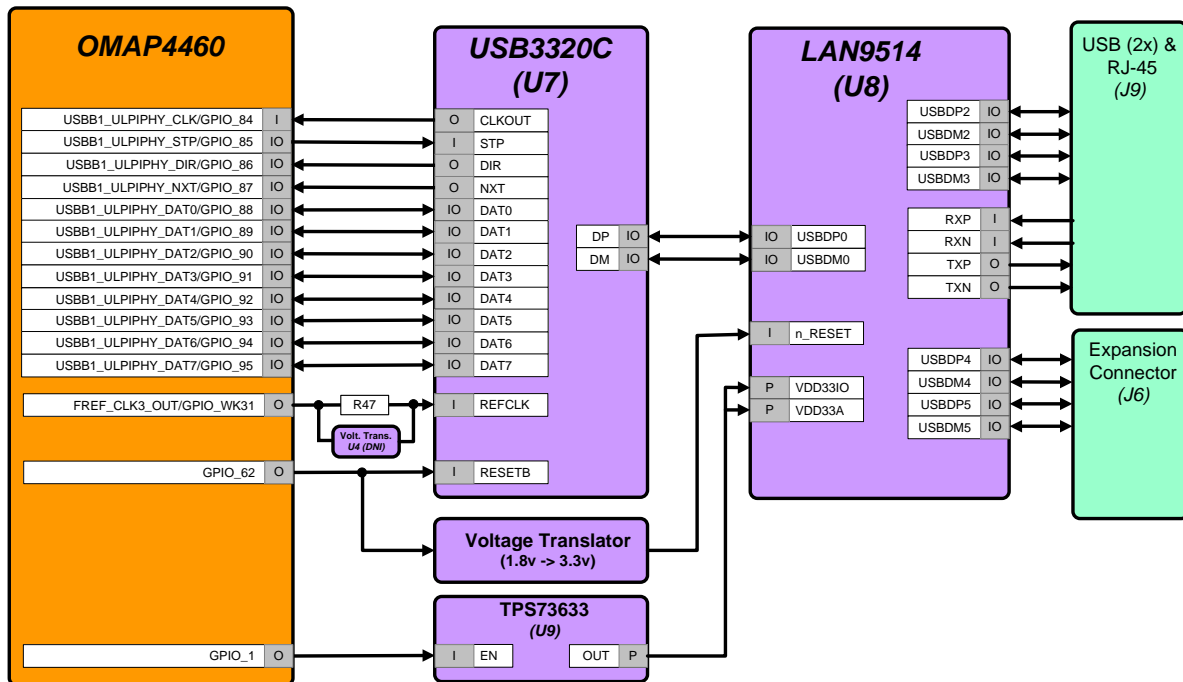

Figure 15 – Panda USBB1 Interface Block Diagram

See Table 10 for the definition of the GPIOs used to provide USB Host Port/Ethernet functions.

GPIO	Dir.	Signal Name	Description
GPIO_1	O	HUB_NPD/ HUB_LDO_EN	Enable to the Hub 3.3V LDO @ U9 (note: this GPIO goes through a voltage translator to provide adequate V_{ih} margin on the LDO enable input). 1 = Enable Hub LDO 0 = Power Down Hub LDO
GPIO_62	O	HUB_NRESET/ HUB_NRESET_3V3	USB/Ethernet Hub Reset 0 = Hub & Phy held in reset 1 = Normal operation.
GPIO_WK31	O	USBB1_PHY_REFCLK	This pin needs to be used as FREF_CLK3_OUT, and programmed to output 19.2 MHz

Table 10: USB Host Port/Ethernet GPIO Definitions

2.17 Expansion Connectors (J3 & J6)

The Pandaboard ES provides locations for two 28-pin, 0.1” through-hole expansion connectors, J3 and J6, to support platform expansion (these connectors are not mounted on the current Pandaboard ES). The placement of these connectors on the Panda PCB is shown below. On both connectors, the top left pin is pin 1 and odd numbered pins are on the top row of the connector, and even numbered pins are on the bottom row. See Figure 16 for the placement and orientation of these two connectors on the Pandaboard ES. The distance between pin 1 of the two connectors is 300 mils or 7.62mm. Note that since these are through-hole connectors, boards can be designed to plug into the Pandaboard ES from either top or bottom, depending on user preference.

See Table 11 for the pinout of expansion connector “A” and Table 12 for the pinout of expansion connector “B”. These tables show the primary function that is available on the connector pin, along with the alternate function that can be selected by changing the OMAP4460 pin multiplexing. Some of the OMAP I/Os have more than two possible functions, see Table 22 on page 55 for a complete list of the functions available.

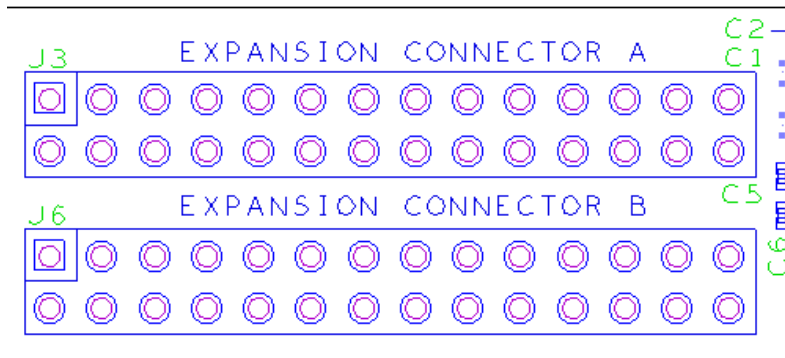

Figure 16 – Expansion Connector PCB Placement/Orientation

J3 Pin #	OMAP Ball #	Primary Function	Secondary Function	Description of Pandaboard ES Usage
1	---	VIO_1V8	---	1.8V I/O Power
2	---	DCIN_JACK	---	5Vdc Input Power
3	B16	GPMC_AD7	SDMMC2_DAT7	GPMC Address/Data Bit 7
4	AH23	MCSP1_CS3	GPIO_140	SPI1 Chip Select 3 (also UART1_RTS)
5	A16	GPMC_AD6	SDMMC2_DAT6	GPMC Address/Data Bit 6
6	AH19	UART4_TX	GPIO_156	UART4 Transmit Data
7	D15	GPMC_AD5	SDMMC2_DAT5	GPMC Address/Data Bit 5
8	AG20	UART4_RX	GPIO_155	UART4 Receive Data
9	C15	GPMC_AD4	SDMMC2_DAT4	GPMC Address/Data Bit 4
10	AF23	MCSP1_CS1	GPIO_138	SPI1 Chip Select 1 (also UART1_RX)
11	D13	GPMC_AD3	SDMMC2_DAT3	GPMC Address/Data Bit 3
12	AG22	MCSP1_SIMO	GPIO_136	SPI1 Slave In Master Out
13	C13	GPMC_AD2	SDMMC2_DAT2	GPMC Address/Data Bit 2
14	AG23	MCSP1_CS2	GPIO_139	SPI1 Chip Select 2 (also UART1_CTS)
15	D12	GPMC_AD1	SDMMC2_DAT1	GPMC Address/Data Bit 1
16	AE23	MCSP1_CS0	GPIO_137	SPI1 Chip Select 0
17	C12	GPMC_AD0	SDMMC2_DAT0	GPMC Address/Data Bit 0
18	AE22	MCSP1_SOMI	GPIO_135	SPI1 Slave Out Master In
19	B12	GPMC_NWE	SDMMC2_CMD	GPMC Write Enable
20	AF22	MCSP1_CLK	GPIO_134	SPI1 Clock Out
21	B11	GPMC_NOE	SDMMC2_CLK	GPMC Output Enable
22	D19	GPMC_AD15	GPIO_39	GPMC Address/Data Bit 15
23	AH22	I2C4_SDA	GPIO_133	I2C4 Serial Data
24	AG21	I2C4_SCL	GPIO_132	I2C4 Serial Clock
25	---	REGEN1	---	TWL6030 REGEN1
26	E7	SYS_NRESPWRON	---	Power On Reset
27	---	DGND	---	Digital Ground
28	---	DGND	---	Digital Ground

Table 11: Expansion Connector “A” Pin Definitions (J3)

J6 Pin #	OMAP Ball #	Primary Function	Secondary Function	Description of Pandaboard ES Usage
1	---	VBUS_3	---	VBUS out from USB Host Port #3
2	---	VBUS_4	---	VBUS out from USB Host Port #4
3	---	USBH3_DM	---	USB Host Port #3 Data Minus
4	---	USBH4_DM	---	USB Host Port #4 Data Minus
5	---	USBH3_DP	---	USB Host Port #3 Data Plus
6	---	USBH4_DP	---	USB Host Port #4 Data Plus
7	---	DGND	---	Digital Ground
8	---	DGND	---	Digital Ground
9	C19	GPMC_AD14	GPIO_38	GPMC Address/Data Bit 14
10	D18	GPMC_AD13	GPIO_37	GPMC Address/Data Bit 13
11	AF7	SYS_NRESWARM	---	Warm Reset
12	---	PB_POWER_ON	---	Power on input to TWL6030 (ref. to VBAT)
13	---	HFL_P	---	Hands Free Left Speaker Out (+)
14	AG24	H_DMTIMER11_PWM	GPIO_121	Display PWM Control
15	---	HFL_N	---	Hands Free Left Speaker Out (-)
16	---	VDD_VAUX1	---	VAUX1 from TWL6030
17	C18	GPMC_AD12	GPIO_36	GPMC Address/Data Bit 13
18	C16	GPMC_AD8	GPIO_32	GPMC Address/Data Bit 8
19	B26	GPMC_WAIT0	GPIO_61	GPMC Wait input 0
20	D16	GPMC_AD9	GPIO_33	GPMC Address/Data Bit 9
21	C25	GPMC_NWP	GPIO_54	GPMC Write Protect
22	C17	GPMC_AD10	GPIO_34	GPMC Address/Data Bit 10
23	B22	GPMC_CLK	GPIO_55	GPMC Clock Out
24	D17	GPMC_AD11	GPIO_35	GPMC Address/Data Bit 11
25	B25	GPMC_NCS0	GPIO_50	GPMC Chip Select 0
26	D25	GPMC_NADV_ALE	GPIO_56	GPMC Address Valid/Address Latch Enable
27	C21	GPMC_NCS1	GPIO_51	GPMC Chip Select 1
28	C23	GPMC_NBE0_CLE	GPIO_59	GPMC Byte Enable 0/Command Latch Enable

Table 12: Expansion Connector “B” Pin Definitions (J6)

2.18 Camera Expansion Connector (J17)

The Pandaboard ES does not provide an onboard camera sensor, but does provision for a 30-pin camera connector. This camera connector receives the five CSI-2 lanes of the OMAP4460 CSI21 camera interface as well as GPIOs for use on a plug-in camera module.

See Table 13 below for the pinout of the camera expansion connector.

NOTE: *the GPIOs listed below don’t have specific functions defined yet, as there has been no camera module designed. These GPIOs will be user-definable per the camera module implementation.*

J17 Pin #	OMAP Ball #	Signal Name	Signal Description
1	---	DGND	Signal Ground
2	---	DGND	Signal Ground
3	R26	CSI21_DX0	CSI Signal Lane 0 Data X
4	V26	CSI21_DX3	CSI Signal Lane 3 Data X
5	R25	CSI21_DY0	CSI Signal Lane 0 Data Y
6	V25	CSI21_DY3	CSI Signal Lane 3 Data Y
7	---	DGND	Signal Ground
8	---	DGND	Signal Ground
9	T26	CSI21_DX1	CSI Signal Lane 1 Data X
10	W26	CSI21_DX4	CSI Signal Lane 4 Data X
11	T25	CSI21_DY1	CSI Signal Lane 1 Data Y
12	W25	CSI21_DY4	CSI Signal Lane 4 Data Y
13	---	DGND	Signal Ground
14	---	DGND	Signal Ground
15	U26	CSI21_DX2	CSI Signal Lane 2 Data X
16	B17	H_GPIO_40	OMAP GPIO_40
17	U25	CSI21_DY2	CSI Signal Lane 2 Data Y
18	B20	H_GPIO_45	OMAP GPIO_45
19	---	DGND	Signal Ground
20	V27	H_CAM_GLB_RESET	Camera Global Reset or GPIO_83
21	W27	H_I2C3_SCL	I2C3 Serial Clock
22	T27	H_CAM_SHUTTER	Camera Shutter or GPIO_81
23	Y27	H_I2C3_SDA	I2C3 Serial Data
24	U27	H_CAM_STROBE	Camera Strobe or GPIO_82
25	B21	H_GPIO_47	OMAP GPIO_47
26	B19	H_GPIO_44	OMAP GPIO_44
27	AA28	H_FREQ_CLK1_OUT	OMAP Camera Clock In
28	B18	H_GPIO_42	OMAP GPIO_42
29	---	VBAT	Battery Voltage In
30	---	VDD_VAUX3	TWL6030 VAUX3 LDO (adjustable from 1.0V to 3.0V)

Table 13: Camera Expansion Connector Pin Definitions (J17)

2.19 JTAG Connector (J8)

The Pandaboard ES provides a 14-pin 0.1" (2.54mm) pitch through-hole connector at J8 as shown in Figure 17 below. In the figure below, pin 1 is the lower left pin and pin 2 is directly above it. Odd number pins are on the bottom side of the connector, and even numbered pins are along the top. Pin 6 is removed to comply with the keying on the JTAG pods.

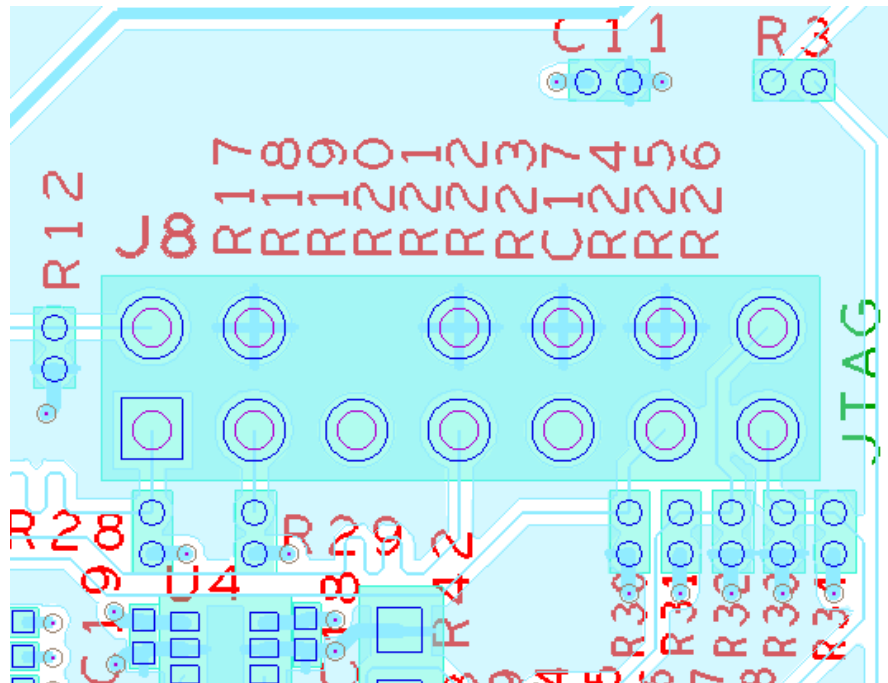

Figure 17 – 14-pin JTAG Connector (J8)

See Table 14 for a description of the pins their connectivity to OMAP4460, and their function on this connector.

J8 Pin #	OMAP Ball #	Signal Name	Signal Description
1	AH1	H JTAG TMS	JTAG Test Mode Select
2	AH2	H JTAG NTRST	JTAG Test Reset (Active low)
3	AE1	H JTAG TDI	JTAG Test Data In
4,8,10,12	----	DGND	Signal Ground
5	---	VIO 1V8	1.8V JTAG Power
6	---	----	N/A
7	AE2	H JTAG TDO	JTAG Test Data Out
9	AE3	H JTAG RTCK	JTAG Return Clock Out
11	AG1	H JTAG TCK	JTAG Clock In
13	M2	H DPM EMU0	Emulator I/O 0
14	N2	H DPM EMU1	Emulator I/O 1

Table 14: JTAG Connector Pinout (J8)

2.20 LED Indicators

The Pandaboard ES provides three LED indicators. See Figure 18 for the location of these three LEDs on the Panda PCB.

LEDs D1 and D2 are green LEDs. D1 is controlled via OMAP4460 GPIO_110 (ball AD27), while D2 is controlled via OMAP4460 GPIO_WK8 (ball AC3). For both of these LEDs, writing the GPIO high will turn on the LED, while writing it low will turn off the LED.

LED D3 is a red LED that is controlled automatically via onboard circuitry. This LED being illuminated indicates an overvoltage condition on the input DC supply (i.e. a supply of greater than 5V has been plugged into P3). The supervisor IC at U19 on sheet 2 of the schematics monitors the voltage from the DC input jack (through a voltage divider to set the appropriate threshold). If a DC supply of more than 5V is plugged into the Pandaboard ES, the U19 output reset will be negated, which will turn on the red LED at D3 and disable load switch U16 on sheet 2 of the schematic, which will remove 5V power to the remainder of the Pandaboard ES circuitry. This is intended to prevent damage to onboard circuitry.

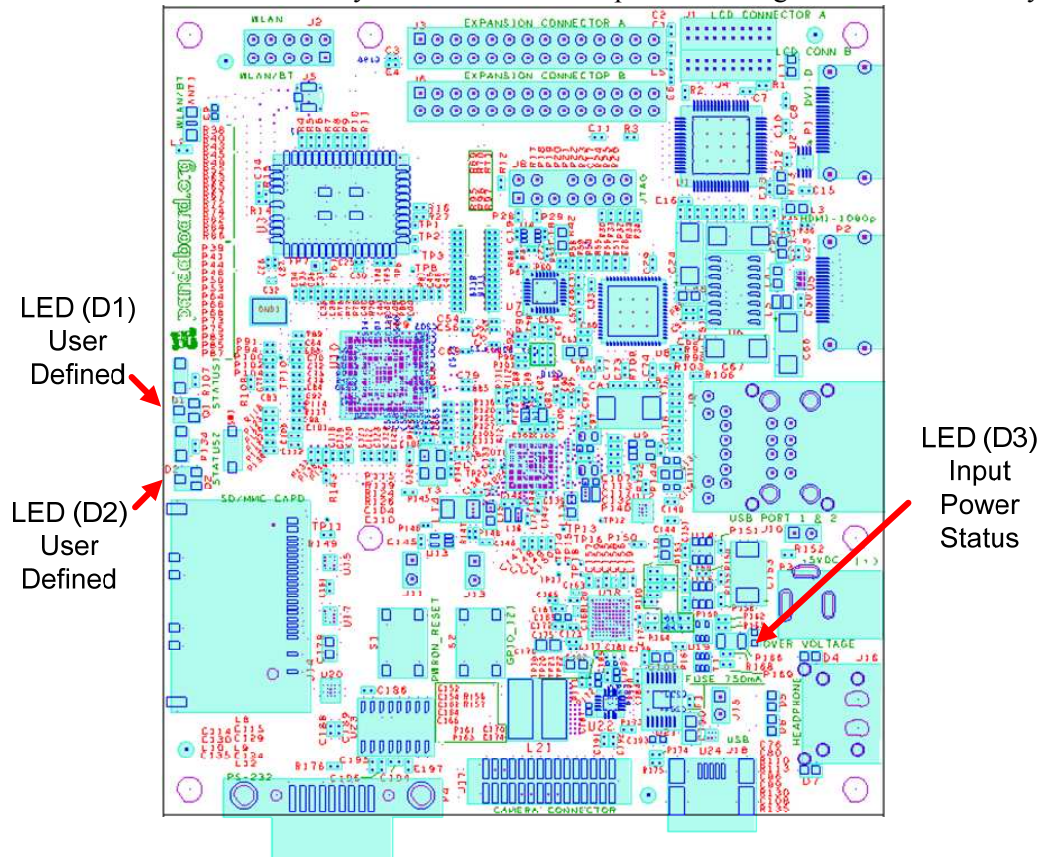

Figure 18 – Pandaboard ES LED Locations

2.21 User Interface Features

Described below are the user features that are incorporated in the OMAP4460 Pandaboard ES.

2.21.1 S1 – Push Button Switch

S1 is a momentary push-button switch that may be depressed to initiate a power-on reset of the Pandaboard ES. The normal power-on output from the TWL6030 is driven through an open-collector driver, and the output of this switch is tied to the output of the output of the open-collector gate.

2.21.2 S2 - Push Button Switch

S2 is a momentary push-button switch whose output is tied to GPIO_113 on the Pandaboard ES. Depressing this switch will momentarily ground GPIO_113. For proper operation of this switch, the internal pull on this signal must be enabled, and it must be set to a pull-up NOT a pull-down.

2.21.3 SW1 – Dip/Slide Switch

SW1 is slide switch that is used to provide the Pandaboard ES user with the desired value on the SYSBOOT3 input into the OMAP4460. Having this switch in the open position will cause SYSBOOT3 to be sampled as a logic '1' at reset, while having it in the closed position will cause SYSBOOT3 to be sampled low at reset.

2.22 I²C Device Mapping

The OMAP4460 Pandaboard ES contains four different I²C busses that are provided by the OMAP4460 (I²C1, I²C2, I²C3, and I²C4). The paragraphs below detail the seven bit I²C addresses for each device on the different I²C busses. The write and read addresses are derived by adding a '0' or '1' respectively, to the LSB of the address given below.

2.22.1 OMAP I²C1

<i>Device</i>	<i>Function</i>	<i>I2C Address</i>
TWL6030	Phoenix Power IC	0x48, 0x49, 0x4A
TWL6040	Phoenix Audio IC	0x4B

Table 15: OMAP I²C1 Device Addresses

2.22.2 OMAP I²C2

<i>Device</i>	<i>Function</i>	<i>I2C Address</i>
Display Expansion Connector (J1/J4)	External LCD Control (e.g. touchscreen)	TBD
DSI Expansion Connector (J7)	DSI Connector Touchscreen I/F Control	TBD

Table 16: OMAP I²C2 Device Addresses

2.22.3 OMAP I²C3

<i>Device</i>	<i>Function</i>	<i>I2C Address</i>
DVI-D connector (P1)	Control of television set connected via P1	TBD
Camera Expansion connector (J17)	Camera Module Control	TBD

Table 17: OMAP I²C3 Device Addresses

2.22.4 OMAP I²C4

<i>Device</i>	<i>Function</i>	<i>I2C Address</i>
Expansion Connectors (J6)	Future expansion	TBD

Table 18: OMAP I²C4 Device Addresses

3 Pandaboard ES S/W Interface

This chapter provides details of interest regarding the SW interface of the Pandaboard ES implementation.

3.1 Readable Board Revision

The OMAP4460 Panda Board provides a readable PCB revision that may be read by Software to determine what board is being used. These board ID bits are shown below for the OMAP4460 and OMAP4430 Pandaboard ESs. BOARD_ID2 and BOARD_ID0 stayed on the same GPIOs (GPIO_171 and GPIO_182, respectively), but BOARD_ID1 changed from GPIO_101 on the 4430 Pandaboard ES to GPIO_48 on the OMAP4460 Pandaboard ES. This was necessary because GPIO_101 was utilized as the tearing effect signal to the new DSI Display Expansion connector at J7. Values are as shown in Table 19 below.

BOARD_ID4	BOARD_ID3	BOARD_ID2	BOARD_ID1	BOARD_ID0
OMAP4460 Pandaboard ES				
GPIO_2	GPIO_3	GPIO_171	GPIO_48	GPIO_182
0	0	0	1	1
OMAP4430 Pandaboard ES				
N/A ¹	N/A ¹	GPIO_171	GPIO_101	GPIO_182
1	1	0	1	1

Table 19: Board ID Read Values

¹ – GPIO_2 and GPIO_3 are unused on the OMAP4430 Pandaboard ES, and if read, will both be read back as '1'

3.2 Pandaboard ES Pin Multiplexing

3.2.1 Panda Base Platform Pin Multiplexing

See Table 20 for a listing of the OMAP pin multiplexing required for the OMAP4460 processor on the Pandaboard ES. This table only includes the GPIOs that are connected and required for operation of the as-shipped configuration of the Pandaboard ES. Unused pins are not included here as well as any GPIOs that go to the onboard connectors. GPIOs that are connected to the Camera Expansion connector at J17 are listed in Table 21 on page 54, while the signals connected to the Generic Expansion connectors at J3 and J6 may be found in Table 22 on page 55.

GPIO	OMAP Ball #	Mux Mode	Signal Name	Description of Pandaboard ES Usage
0	J27	3	H_GPIO_0	DVI-D Transmitter (TFP410) Power Down

GPIO	OMAP Ball #	Mux Mode	Signal Name	Description of Pandaboard ES Usage
1	H27	3	HUB_NPD	Ethernet/USB Hub LDO Power Enable
2	L27	3	GPIO_2	Board ID Bit 4
3	K27	3	GPIO_3	Board ID Bit 3
11	M2	0	DPM_EMU0	JTAG Emulator 0 I/O
12	N2	0	DPM_EMU1	JTAG Emulator 1 I/O
14	V1	5	DISPC2_DATA10	Parallel Display Data Bit 10
15	V2	5	DISPC2_DATA9	Parallel Display Data Bit 9
16	W1	5	DISPC2_DATA16	Parallel Display Data Bit 16
17	W2	5	DISPC2_DATA17	Parallel Display Data Bit 17
18	W3	5	DISPC2_HSYNC	Parallel Display Horizontal Sync
19	W4	5	DISPC2_PCLK	Parallel Display Pixel Clock
20	Y2	5	DISPC2_VSYNC	Parallel Display Vertical Sync
21	Y3	5	DISPC2_DE	Parallel Display Data Enable
22	Y4	5	DISPC2_DATA8	Parallel Display Data Bit 8
23	AA1	5	DISPC2_DATA7	Parallel Display Data Bit 7
24	AA2	5	DISPC2_DATA6	Parallel Display Data Bit 6
25	AA3	5	DISPC2_DATA5	Parallel Display Data Bit 5
26	AA4	5	DISPC2_DATA4	Parallel Display Data Bit 4
27	AB2	5	DISPC2_DATA3	Parallel Display Data Bit 3
28	AB3	5	DISPC2_DATA2	Parallel Display Data Bit 2
41	A18	3	GPIO_41	HDMI Transceiver Level Shifter Output Enable
43	A19	3	GPIO_43	Wireless LAN Enable
46	A21	3	GPIO_46	Bluetooth Enable
48	C20	3	GPIO_48	Board ID Bit 1
49	D20	3	GPIO_49	Bluetooth Wakeup
53	C22	3	GPIO_53	WLAN Interrupt In
60	D22	3	GPIO_60	HDMI DC/DC-Hot Plug Enable
62	B23	3	GPIO_62	Ethernet/USB Hub Reset
63	B9	0	HDMI_HPD	HDMI Hot Plug Detect
64	B10	0	HDMI_CEC	HDMI Consumer Electronic Control
65	A8	0	HDMI_DDC_SCL	Display Data Channel Serial Clock
66	B8	0	HDMI_DDC_SDA	Display Data Channel Serial Data
84	AE18	4	ULPIPHY_CLK	USBB1 ULPI Clock (Hub)
85	AG19	4	ULPIPHY_STP	USBB1 ULPI Stop (Hub)
86	AF19	4	ULPIPHY_DIR	USBB1 ULPI Direction (Hub)
87	AE19	4	ULPIPHY_NXT	USBB1 ULPI Next (Hub)
88	AF18	4	ULPIPHY_DAT0	USBB1 ULPI Data Bit 0 (Hub)
89	AG18	4	ULPIPHY_DAT1	USBB1 ULPI Data Bit 1 (Hub)
90	AE17	4	ULPIPHY_DAT2	USBB1 ULPI Data Bit 2 (Hub)

GPIO	OMAP Ball #	Mux Mode	Signal Name	Description of Pandaboard ES Usage
91	AF17	4	ULPIPHY_DAT3	USBB1 ULPI Data Bit 3 (Hub)
92	AH17	4	ULPIPHY_DAT4	USBB1 ULPI Data Bit 4 (Hub)
93	AE16	4	ULPIPHY_DAT5	USBB1 ULPI Data Bit 5 (Hub)
94	AF16	4	ULPIPHY_DAT6	USBB1 ULPI Data Bit 6 (Hub)
95	AG16	4	ULPIPHY_DAT7	USBB1 ULPI Data Bit 7 (Hub)
100	D2	0	SDMMC1_CLK	SDMMC Card Cage Clock (1.8v/3.0V)
101	E3	0	SDMMC1_CMD	SDMMC Card Cage Command (1.8v/3.0V)
101	A24	3	GPIO_101	Board ID Input Bit 1
102	E4	0	SDMMC1_DAT0	SDMMC Card Cage Data Bit 0 (1.8v/3.0V)
103	E2	0	SDMMC1_DAT1	SDMMC Card Cage Data Bit 1 (1.8v/3.0V)
104	E1	0	SDMMC1_DAT2	SDMMC Card Cage Data Bit 2 (1.8v/3.0V)
105	F4	0	SDMMC1_DAT3	SDMMC Card Cage Data Bit 3 (1.8v/3.0V)
106	F3	0	SDMMC1_DAT4	SDMMC Card Cage Data Bit 4 (1.8v/3.0V)
107	F1	0	SDMMC1_DAT5	SDMMC Card Cage Data Bit 5 (1.8v/3.0V)
108	G4	0	SDMMC1_DAT6	SDMMC Card Cage Data Bit 6 (1.8v/3.0V)
109	G3	0	SDMMC1_DAT7	SDMMC Card Cage Data Bit 7 (1.8v/3.0V)
110	AD27	3	GPIO_110	LED D1 On/Off Control
113	AC28	3	GPIO_113	Input from push-button switch S2
114	AC26	0	MCBSP1_CLKX	BT Audio I2S Clock
115	AC25	0	MCBSP1_DR	BT Audio I2S Data Out
116	AB25	0	MCBSP1_DX	BT Audio I2S Data In
117	AC27	0	MCBSP1_FSX	BT Audio I2S Frame Sync
118	AH26	0	ABE_CLKS	Clock input from TWL6030 Audio Companion IC
121	AG24	5	DMTIMER11_PWM_EVT	Display Expansion Connector(s) PWM Control
122	AH24	3	GPIO_122	DVI-D Monitor Sense Input
123	AB26	0	UART2_CTS	Bluetooth Host Control Interface Request to Send
124	AB27	0	UART2_RTS	Bluetooth Host Control Interface Clear to Send
125	AA25	0	UART2_RX	Bluetooth Host Control Interface Transmit Data
126	AA26	0	UART2_TX	Bluetooth Host Control Interface Receive Data
127	AA27	3	GPIO_127	TWL6040 Audio Power On
128	C26	0	I2C2_SCL	I2C2 Serial Clock
129	D26	0	I2C2_SDA	I2C2 Serial Data
130	W27	0	I2C3_SCL	I2C3 Serial Clock
131	Y27	0	I2C3_SDA	I2C3 Serial Data
132	AG21	0	I2C4_SCL	I2C4 Serial Clock
133	AH22	0	I2C4_SDA	I2C4 Serial Data
141	F27	0	UART3_CTS	Debug Terminal RS-232 Clear to Send
142	F28	0	UART3_RTS	Debug Terminal RS-232 Request to Send
143	G27	0	UART3_RX	Debug Terminal RS-232 Receive Data

GPIO	OMAP Ball #	Mux Mode	Signal Name	Description of Pandaboard ES Usage
144	G28	0	UART3_TX	Debug Terminal RS-232 Transmit Data
145	AE5	0	SDMMC5_CLK	WLAN SDIO Clock Line
146	AF5	0	SDMMC5_CMD	WLAN SDIO Command Line
147	AE4	0	SDMMC5_DAT0	WLAN SDIO Data Bit 0
148	AF4	0	SDMMC5_DAT1	WLAN SDIO Data Bit 1
149	AG3	0	SDMMC5_DAT2	WLAN SDIO Data Bit 2
150	AF3	0	SDMMC5_DAT3	WLAN SDIO Data Bit 3
158	AF12	5	DISPC_DATA23	Parallel Display Data Bit 23
159	AE12	5	DISPC_DATA22	Parallel Display Data Bit 22
160	AG13	5	DISPC_DATA21	Parallel Display Data Bit 21
161	AE11	5	DISPC_DATA20	Parallel Display Data Bit 20
162	AF11	5	DISPC_DATA19	Parallel Display Data Bit 19
163	AG11	5	DISPC_DATA18	Parallel Display Data Bit 18
164	AH11	5	DISPC_DATA15	Parallel Display Data Bit 15
165	AE10	5	DISPC_DATA14	Parallel Display Data Bit 14
166	AF10	5	DISPC_DATA13	Parallel Display Data Bit 13
167	AG10	5	DISPC_DATA12	Parallel Display Data Bit 12
168	AE9	5	DISPC_DATA11	Parallel Display Data Bit 11
171	G26	3	GPIO_171	Board ID Bit 2
179	B5	0	USBA0_OTG_DP	Internal USB Transceiver Data Plus
180	B4	0	USBA0_OTG_DM	Internal USB Transceiver Data Minus
181	AA28	0	FREF_CLK1_OUT	Camera Expansion Connector
182	Y28	0	GPIO_182	Board ID Bit 0
183	AF6	0	SYS_NIRQ2	System Interrupt from TWL6040 Audio IC
184	F26	0	SYS_BOOT0	SYSBOOT Input 0
185	E27	0	SYS_BOOT1	SYSBOOT Input 1
186	E26	0	SYS_BOOT2	SYSBOOT Input 2
187	E25	0	SYS_BOOT3	SYSBOOT Input 3
188	D28	0	SYS_BOOT4	SYSBOOT Input 4
189	D27	0	SYS_BOOT5	SYSBOOT Input 5
190	AB4	5	DISPC2_DATA1	Parallel Display Data Bit 1
191	AC4	5	DISPC2_DATA0	Parallel Display Data Bit 0
WK5	AG8	0	FREF_SLICER_IN	38.4MHz Clock Input
WK6	AD2	2	GPIO_WK6	MSECURE output to TWL6030 (RTC related)
WK7	AC2	3	GPIO_WK7	TPS62361 VSEL0 control
WK8	AC3	3	GPIO_WK8	LED D2 On/Off Control
WK9	AF8	0	SYS_BOOT6	SYSBOOT Input 6
WK10	AE8	0	SYS_BOOT7	SYSBOOT Input 7
WK31	AD4	0	FREF_CLK3_OUT	USBB1 Phy Reference Clock (19.2 MHz)

Table 20: Pandaboard ES OMAP4460 Pin Multiplexing

3.2.2 Camera Expansion Connector Pin Multiplexing

See Table 21 for a description of the pin multiplexing possibilities for the camera expansion board signals.

GPIO	OMAP Ball #	Mux Mode	Signal Name	Description of Pandaboard ES Usage
40	B17	3	GPIO_40	Camera Expansion Connector (pin 16)
42	B18	3	GPIO_42	Camera Expansion Connector (pin 28)
44	B19	3	GPIO_44	Camera Expansion Connector (pin 26)
45	B20	3	GPIO_45	Camera Expansion Connector (pin 18)
47	B21	3	GPIO_47	Camera Expansion Connector (pin 25)
67	R26	0	CSI21_DX0	Camera Expansion Connector (pin 3)
68	R25	0	CSI21_DY0	Camera Expansion Connector (pin 5)
69	T26	0	CSI21_DX1	Camera Expansion Connector (pin 9)
70	T25	0	CSI21_DY1	Camera Expansion Connector (pin 11)
71	U26	0	CSI21_DX2	Camera Expansion Connector (pin 15)
72	U25	0	CSI21_DY2	Camera Expansion Connector (pin 17)
73	V26	0	CSI21_DX3	Camera Expansion Connector (pin 4)
74	V25	0	CSI21_DY3	Camera Expansion Connector (pin 6)
75	W26	0	CSI21_DX4	Camera Expansion Connector (pin 10)
76	W25	0	CSI21_DY4	Camera Expansion Connector (pin 12)
81	T27	0/3	CAM_SHUTTER	Camera shutter or GPIO_81 (pin 22)
82	U27	0/3	CAM_STROBE	Camera strobe or GPIO_82 (pin 24)
83	V27	0	CAM_GLOBALRESET	Camera Expansion Connector (pin 20)
130	W27	0	I2C3_SCL	I2C3 Serial Clock (pin 21)
131	Y27	0	I2C3_SDA	I2C3 Serial Data (pin 23)
181	AA28	0	FREF_CLK1_OUT	Camera Expansion Connector (pin 27)

Table 21: Camera Expansion Connector (J17) Pin Multiplexing Options

3.2.3 Expansion Connector (J3 & J6) Pin Multiplexing

See Table 22 below for a listing of the IOs connected to the expansion connectors at J3 and J6. GPIOs with multiple mux modes listed have multiple functions that can be supported, depending on the requirements of the particular expansion board being utilized.

GPIO	OMAP Ball #	Mux Mode	Function1	Function2	Function3	Function4
32	C16	0/1/3/5	GPMC_AD8	KPD_ROW0	GPIO_32	SDMMC1_DAT0
33	D16	0/1/3/5	GPMC_AD9	KPD_ROW1	GPIO_33	SDMMC1_DAT1
34	C17	0/1/3/5	GPMC_AD10	KPD_ROW2	GPIO_34	SDMMC1_DAT2
35	D17	0/1/3/5	GPMC_AD11	KPD_ROW3	GPIO_35	SDMMC1_DAT3
36	C18	0/1/3/5	GPMC_AD12	KPD_COL0	GPIO_36	SDMMC1_DAT4
37	D18	0/1/3/5	GPMC_AD13	KPD_COL1	GPIO_37	SDMMC1_DAT5
38	C19	0/1/3/5	GPMC_AD14	KPD_COL2	GPIO_38	SDMMC1_DAT6
39	D19	0/1/3/5	GPMC_AD15	KPD_COL3	GPIO_39	SDMMC1_DAT7
50	B25	0/3	GPMC_NCS0	GPIO_50	----	----
51	C21	0/3	GPMC_NCS1	GPIO_51	----	----
54	C25	0/3/4	GPMC_NWP	GPIO_54	SYS_NDMAREQ1	----
55	B22	0/3/4/5	GPMC_CLK	GPIO_55	SYS_NDMAREQ2	SDMMC1_CMD
56	D25	0/3/4/5	GPMC_NADV_ALE	GPIO_56	SYS_NDMAREQ3	SDMMC1_CLK
59	C23	0/3	GPMC_NBE0_CLE	GPIO_59	----	----
61	B26	0/3	GPMC_WAIT0	GPIO_61	----	----
132	AG21	0/3	I2C4_SCL	GPIO_132	----	----
133	AH22	0/3	I2C4_SDA	GPIO_133	----	----
134	AF22	0/3	MCSP11_CLK	GPIO_134	----	----
135	AE22	0/3	MCSP11_SOMI	GPIO_135	----	----
136	AG22	0/3	MCSP11_SIMO	GPIO_136	----	----
137	AE23	0/3	MCSP11_CS0	GPIO_137	----	----
138	AF23	0/3	MCSP11_CS1	GPIO_138	----	----
139	AG23	0/2/3	MCSP11_CS2	SLIMBUS2_CLOCK	GPIO_139	----
140	AH23	0/2/3	MCSP11_CS3	SLIMBUS2_DATA	GPIO_140	----
155	AG20	0/2/3	UART4_RX	KPD_ROW8	GPIO_155	----
156	AH19	0/2/3	UART4_TX	KPD_COL8	GPIO_156	----
None	C12	0/1	GPMC_AD0	SDMMC2_DAT0	----	----
None	D12	0/1	GPMC_AD1	SDMMC2_DAT1	----	----
None	C13	0/1	GPMC_AD2	SDMMC2_DAT2	----	----
None	D13	0/1	GPMC_AD3	SDMMC2_DAT3	----	----
None	C15	0/1	GPMC_AD4	SDMMC2_DAT4	----	----
None	D15	0/1	GPMC_AD5	SDMMC2_DAT5	----	----
None	A16	0/1	GPMC_AD6	SDMMC2_DAT6	----	----
None	B16	0/1	GPMC_AD7	SDMMC2_DAT0	----	----
None	B11	0/1	GPMC_NOE	SDMMC2_CLK	----	----
None	B12	0/1	GPMC_NWE	SDMMC2_CMD	----	----

Table 22: Expansion Connector (J3 & J6) Pin Multiplexing Options

3.3 OMAP4460 Pandaboard ES Key Components

See Table 23 for a listing of the manufacturers and manufacturer part numbers for some of the key components used on the OMAP4460 Pandaboard ES.

Device / Interface	Under NDA?	Manufacture P/N
Application Processor		
Processor	Yes	TI OMAP4460
Memories/Storage		
DDR	Yes	Elpida 8Gb (POP, S4B) EDB8064B1PB-8D-F
Removable card support	No	KingConn 6-in-One SD/MMC (8 bit Cardcage) SDMM-B0-0016
Removable card ESD protection	No	Texas Instruments TPD6E001RSER
Power		
Power Management (U12)	Yes	Texas Instruments TWL6030
DC Input Connector (P3)	No	CUI, Inc. PJ-002A
USB Power Switch/LDO (U21)	No	Texas Instruments TPS2141IPWP
Input Power SMPS (U22)	No	Texas Instruments TPS54320RHL
Input Voltage Supervisor (U19)	No	Texas Instruments TPS3803G15DCKR
USB/Ethernet Hub Power (U9)	No	Texas Instruments TPS73633DBVR
Clocking		
38.4 MHz oscillator	No	TXC 7X-38.400MBB-T
Video/Display		
HDMI Transceiver + ESD protection	No	Texas Instruments TPD12S015AYFFR
HDMI Connector & DVI-D Connector	No	FCI Connectors 10029449-001RLF

DVI-D Transmitter	No	Texas Instruments TFP410PAP
Audio		
Audio Management	Yes	TI TWL6040
Dual Stacked Audio Jack	No	Kycon STX-4235-3/3-N
MCS		
Wilink™6 Module	No	LS Research, Inc. LS240-WI-01-A20
USB/Ethernet		
Ethernet + 2x USB Host Port Connector	No	Tyco (6620004-1) Belfuse (08C2-1X1T-03)
ULPI USB Phy	No	SMSC USB3320C-EZK
USB/Ethernet Hub Controller	No	SMSC LAN9514-JZX
USB OTG ESD Protection	No	Texas Instruments TPD4S012DRYR
Camera Expansion		
30-pin Camera Expansion Connector	No	Samtec TFM-115-32-S-D-A
Display Expansion		
DSI Display Expansion (40 pin SMT, 0.8mm pitch)	No	Hirose FX6A-40P-0.8SV91
Parallel Display Expansion (2x 20 pin TH, 0.050" pitch)	No	Samtec SFMC-110-T1-F-D
Generic Expansion		
Generic Expansion (2x 28 pin TH, 0.050" pitch)	No	Major League Electronics LSWSS-114-D-02-T-LF

Table 23: OMAP4460 Pandaboard ES Key H/W Components

3.4 OMAP4460 Pandaboard ES Key Component Datasheet URLs

Shown below for convenience are links to datasheets for key Pandaboard ES components.

3.4.1 Connector Datasheets

- Combo Ethernet/2x USB Host Port Connector (J9)
 - <http://www.tycoelectronics.com/catalog/products/en?q=6620004-1>
- Power Input Connector (P3)
 - <http://products.cui.com/adtemplate.asp?brand=electronic-components&invky=7106&catky=619701&subcatky1=447353&subcatky2=632366&subcatky3=405514>
- Dual Audio Jack (J16)
 - http://domino2.kycon.com/catalog_PDF/STX4235.pdf
- DVI-D & HDMI Connectors (P1 & P2)
 - http://portal.fciconnect.com/portal/page/portal/FcicntPublic/Product_Type?appname=catLanding
- Camera Expansion Connector (J17)
 - http://www.samtec.com/documents/webfiles/pdf/TFM_SM.PDF
- DSI Display Expansion Connector (J7)
 - <http://www.hirose-connectors.com/connectors/H205SeriesGaiyou.aspx?c1=FX6&c3=3>

3.4.2 Key Electronic Component Datasheets

- DVI Transmitter (U1)
 - <http://focus.ti.com/docs/prod/folders/print/tfp410.html>
- HDMI Companion Chip – ESD, Level Translator, Charge Pump (U5)
 - <http://www.ti.com/product/tpd12s015a>
- USB Power Switch w/ Integrated LDO (U21)
 - <http://focus.ti.com/docs/prod/folders/print/tps2141.html>
- Switching Power Supply, 3A (U22)
 - <http://www.ti.com/product/tps54320>



- Single Output LDO, 400mA (U9)
 - <http://www.ti.com/product/tps73633>
- Single Voltage Detector, (U19)
 - <http://www.ti.com/product/tps3803g15>
- USB ULPI Phy (U7)
 - <http://www.smsc.com/index.php?tid=143&pid=211>
- USB/Ethernet Hub Controller (U9)
 - <http://www.smsc.com/index.php?tid=300&pid=135&cid=&tab=5>
- Wilink™6 Module (U3)
http://www.lsr.com/products/radio_modules/802.11_BGN_BT/tiwi.shtml





Figure 19 – 38.4 MHz Input Clock Probe Point (h_FREF_ALTCLK_IN_OMAP)

4.1.2 USBB1_PHY_REFCLK Probe Point

The 19.2 MHz reference input clock to the USBB1 Phy device may be probed at R47-1 or U4-4 as shown below in red. These parts are located directly below the 14-pin JTAG connector J8.

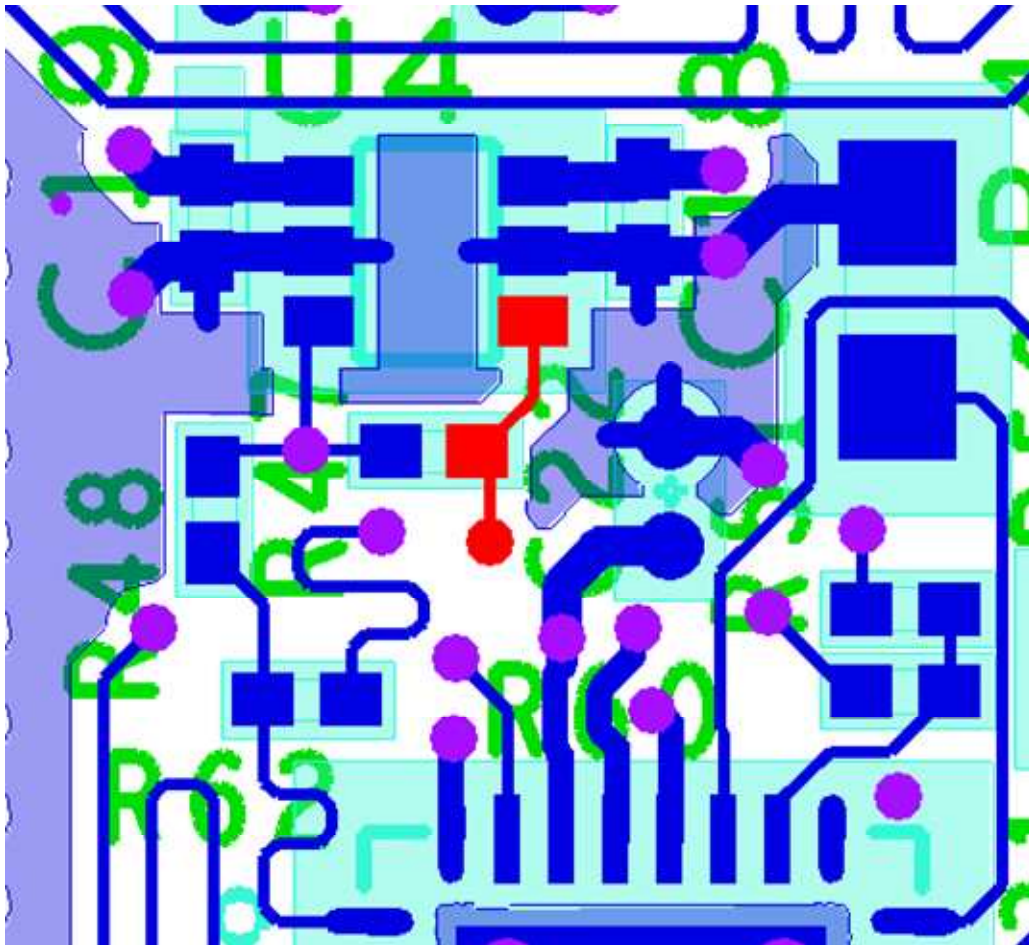

Figure 20 – USB Phy Ref Clock In Probe Point (USBB1_PHY_REFCLK)



4.1.3 CLK32K_AUD Probe Point

The 32.768KHz input clock to the TWL6040 Audio Companion IC may be probed at TP14 as shown in Figure 21. This testpoint may be located between the TWL6040 device at U19 and the TWL6030 Power Companion device at U12.

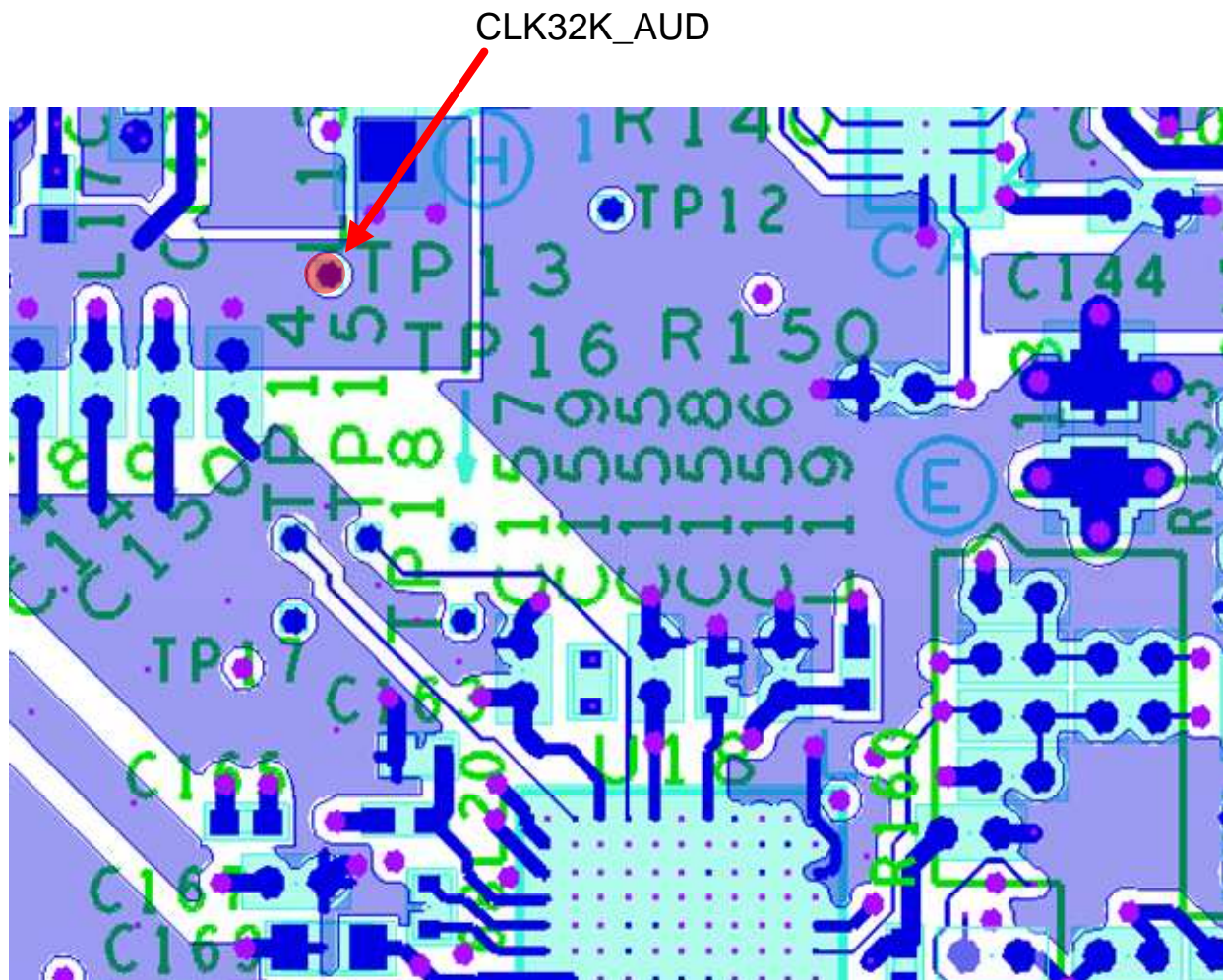

Figure 21 – 32KHz Audio Clock Probe Point (CLK32K_AUD)

4.2 Pandaboard ES Power Rail Signal Access

4.2.1 TWL6030 SMPS Output Probe Points

The outputs of the seven Phoenix SMPS output supplies may be probed around the TWL6030 IC at U11 as shown in Figure 22 below.

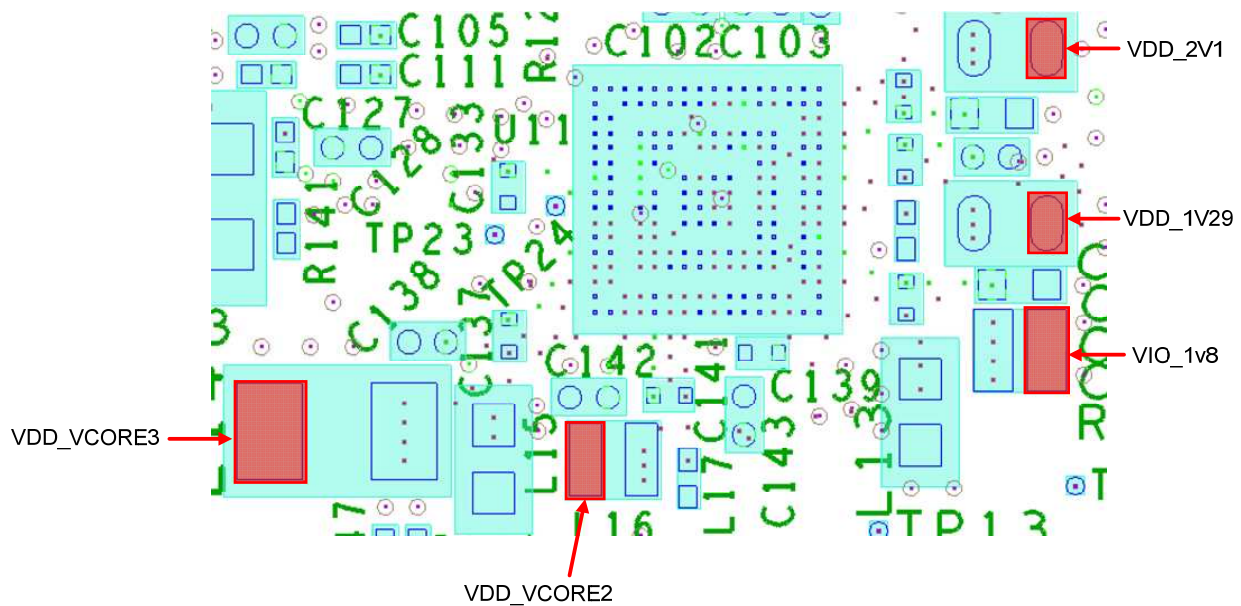
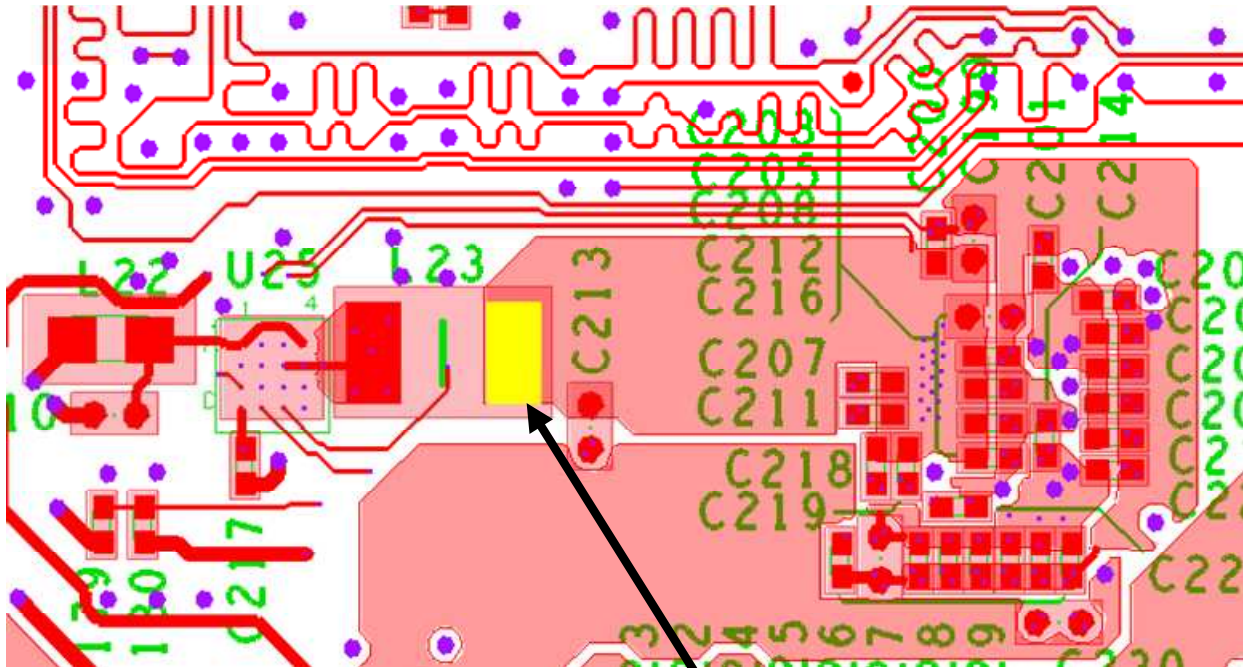

Figure 22 – TWL6030 SMPS Output Probe Points

4.2.2 VDD_CORE1 Output Probe Point

The output of the TPS62361 external supply used to power the VDD_MPU inputs of the OMAP4460 may be probed on the back side of the PCB at L23-1 as shown in Figure 23 below.



VDD_VCORE1

Figure 23 – VDD_CORE1 Output Probe Point

4.2.3 VCXIO LDO Output Probe Point

The outputs of the TWL6030 VCXIO LDO may be probed around the bottom of the OMAP4460 and near the oscillator Y3 as shown in Figure 24 below. The possible probe points are at C123-2, C125-2, R145-1, C109-2, C86-2, C127-2, or C105-2 as shown highlighted in red from left to right in Figure 24.



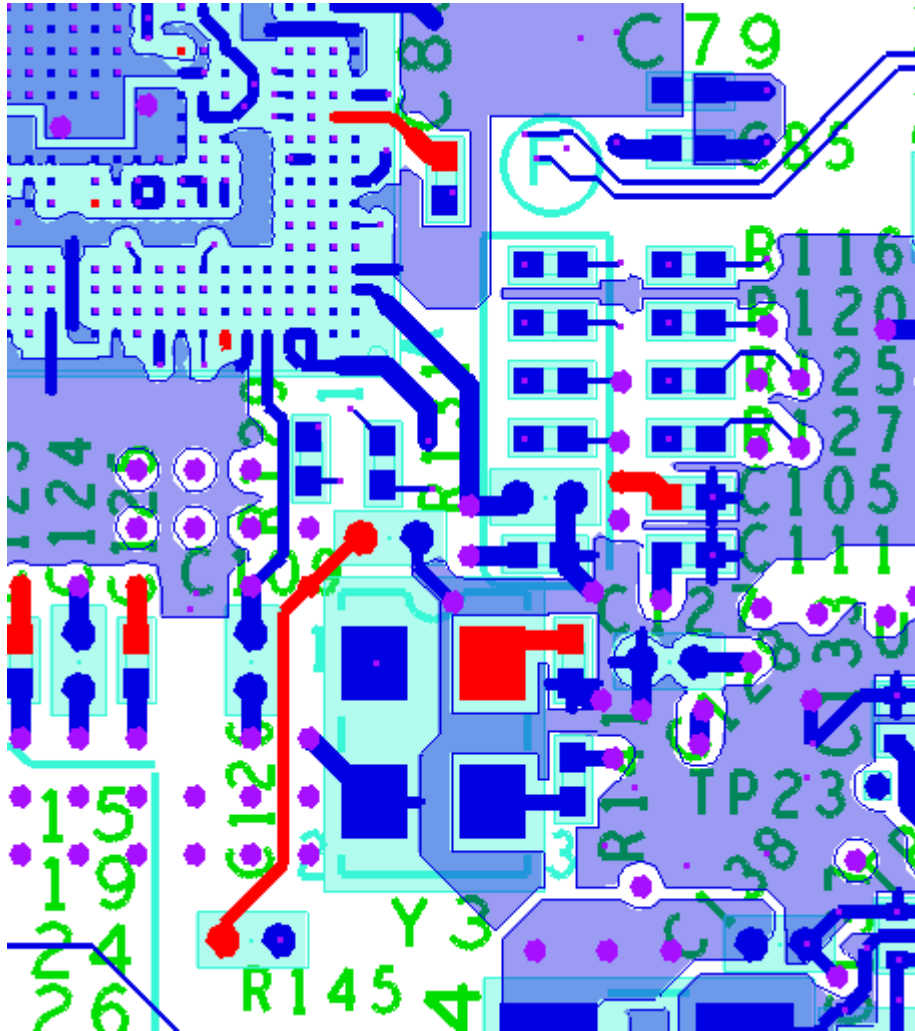

Figure 24 – TWL6030 VCXIO LDO Output Probe Points

4.4 Pandaboard ES Schematic

The following pages contain the PDF schematics for the production Pandaboard ES. The schematics are included in this document for convenience, and this manual will be periodically updated, but for the latest information be sure and check on the Pandaboard.org website. OrCAD 16.3 source files are provided for the Pandaboard ES at the following URL:

<http://Pandaboard.org/content/resources/references>

*These design materials are ***NOT SUPPORTED*** and **DO NOT** constitute a reference design. Only “community” support is allowed via resources at <http://Pandaboard.org/content/community/home>. **THERE IS NO WARRANTY FOR THE DESIGN MATERIALS, TO THE EXTENT PERMITTED BY APPLICABLE LAW. EXCEPT WHEN OTHERWISE STATED IN WRITING THE COPYRIGHT HOLDERS AND/OR OTHER PARTIES PROVIDE THE DESIGN MATERIALS “AS IS” WITHOUT WARRANTY OF ANY KIND, EITHER EXPRESSED OR IMPLIED, INCLUDING, BUT NOT LIMITED TO, THE IMPLIED WARRANTIES OF MERCHANTABILITY AND FITNESS FOR A PARTICULAR PURPOSE. THE ENTIRE RISK AS TO THE QUALITY AND PERFORMANCE OF THE DESIGN MATERIALS IS WITH YOU. SHOULD THE DESIGN MATERIALS PROVE DEFECTIVE, YOU ASSUME THE COST OF ALL NECESSARY SERVICING, REPAIR OR CORRECTION.***

We mean it; these design materials may be totally unsuitable for any purposes.



Rev	Date	Notes
A	8/29/2011	Created from 750-2170-001 rev. D schematic (input power and antenna matching component changes). Added resistor on VBAT to allow overall current measurement.

Table of Contents

Pg# – Schematic Page Name

- 1 – Title Page
- 2 – Input Power
- 3 – Phoenix Power Component
- 4 – Phoenix Audio Component
- 5 – OMAP4460 Symbol A
- 6 – OMAP4460 Symbol B
- 7 – OMAP4460 Symbol C
- 8 – OMAP4460 Debug Interface
- 9 – SDMMC Card Interface + USB Phy (Hub)
- 10 – DVI & HDMI Connector
- 11 – Debug Ethernet
- 12 – Audio Jack/RS-232 Connection
- 13 – Expansion Connectors
- 14 – WLAN Subsystem

OMAP4460 Pandaboard ES Layer
 750-2170-000-6-04
 750-2170-000-6-04
 Date: Wednesday, August 31, 2011
 View: 1 of 14



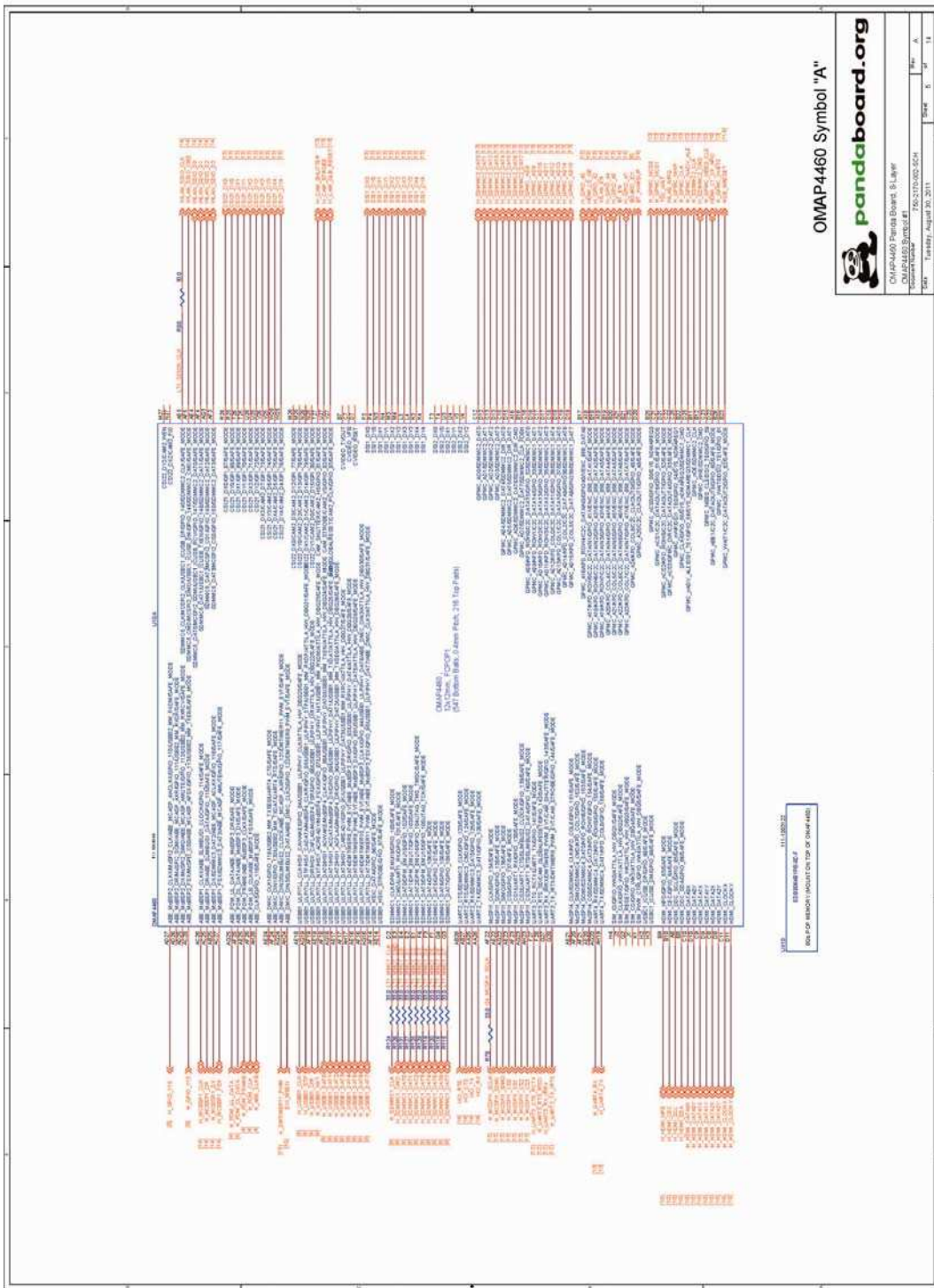

OMAP4460 Symbol "A"
pandaboard.org

OMAP4460 Pandaboard ES Layer	Rev	A
Doc No: DOC-21054-004	Size	11
Date: Tuesday, August 30, 2011	Sheet	72 of 82

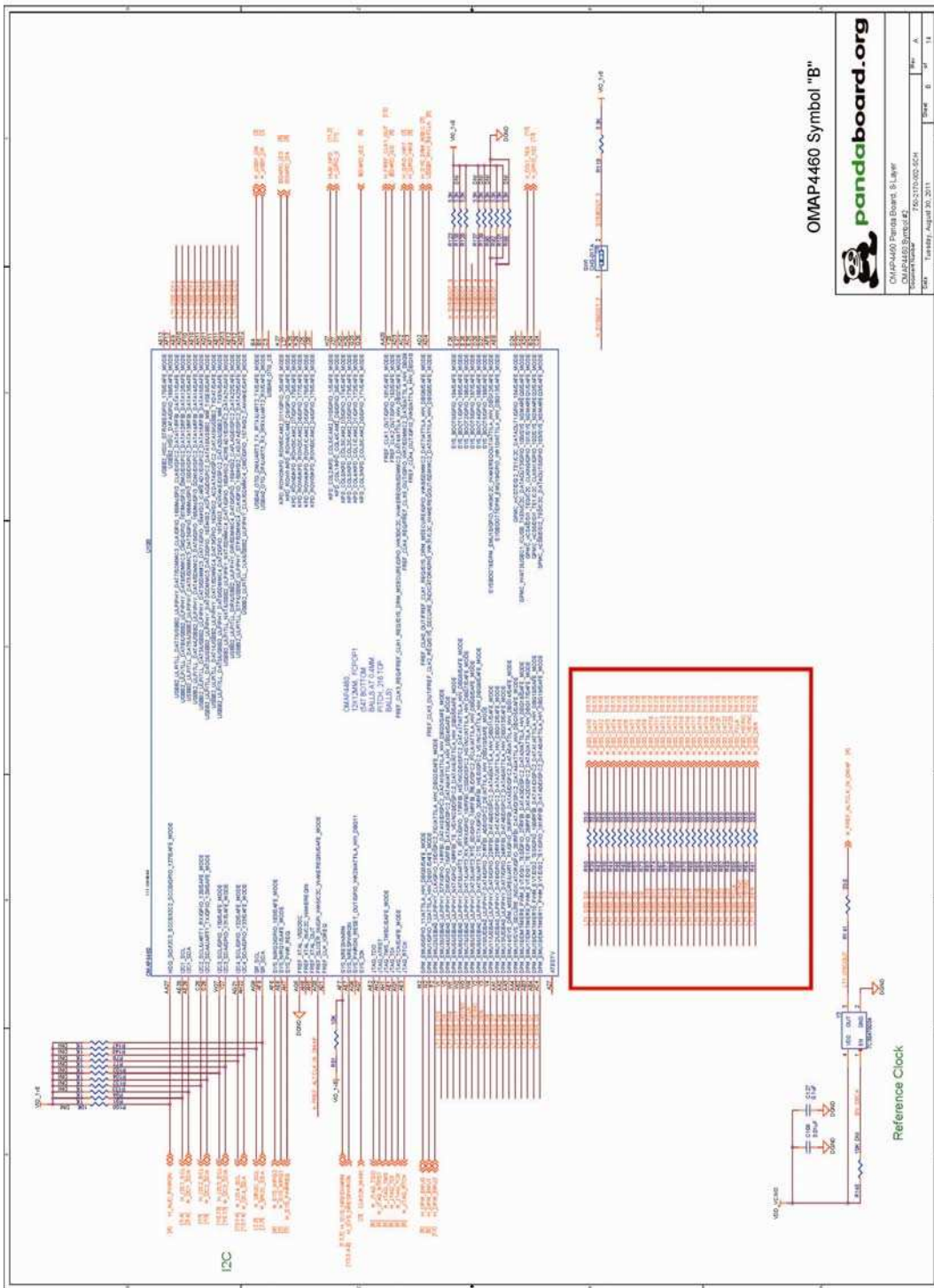

OMAP4460 Symbol "B"



OMAP4460 Pandaboard ES Layer
 BOARD PART NUMBER: PDS-210540-004
 DATE: Tuesday, August 30, 2011

Rev.	0	1	2	3
Size	0	1	2	3

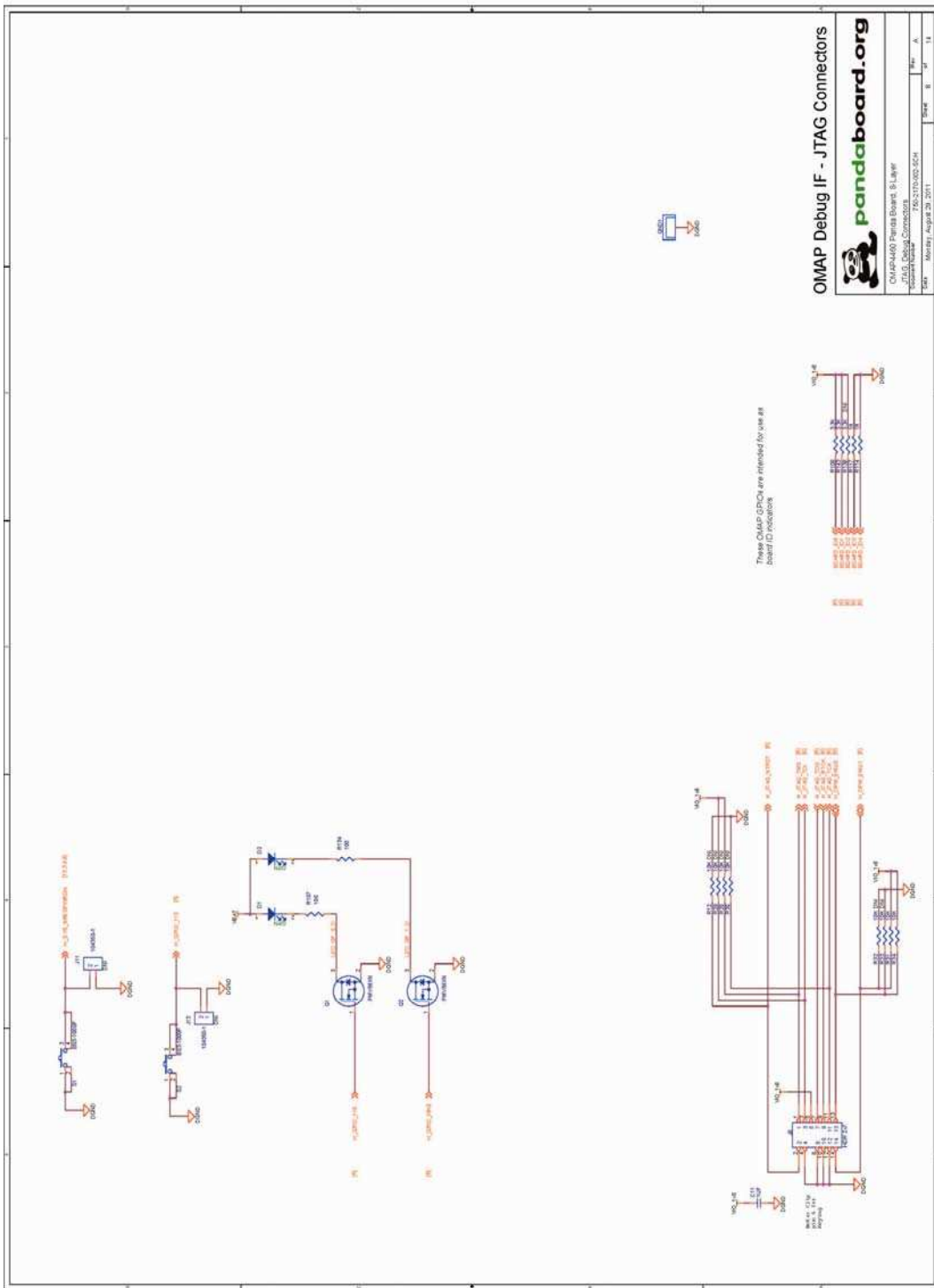

OMAP Debug IF - JTAG Connectors

 OMAP4460 Pandaboard ES Layer
 Technical Reference Manual
 DOC-21054-004
 Rev. A
 Monday, August 29, 2011

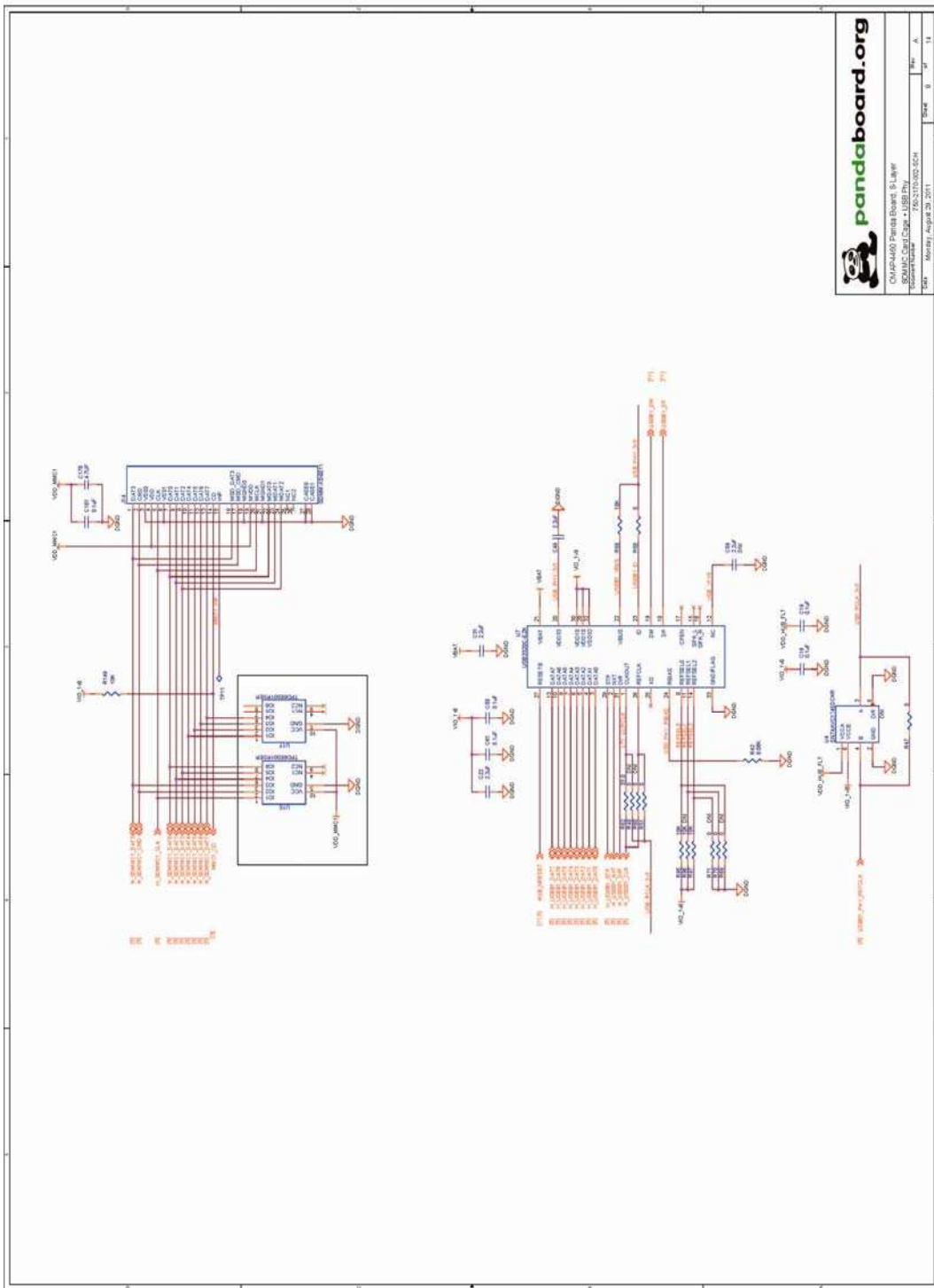

pandaboard.org

OMAP4460 Pandaboard ES Layer 8
 BOARD PART NUMBER: L3200-00000-0004
 DATE: Monday, August 22, 2011

Rev	0	1	2	3	4	5	6	7	8	9	10	11	12	13	14
Size	0	1	2	3	4	5	6	7	8	9	10	11	12	13	14



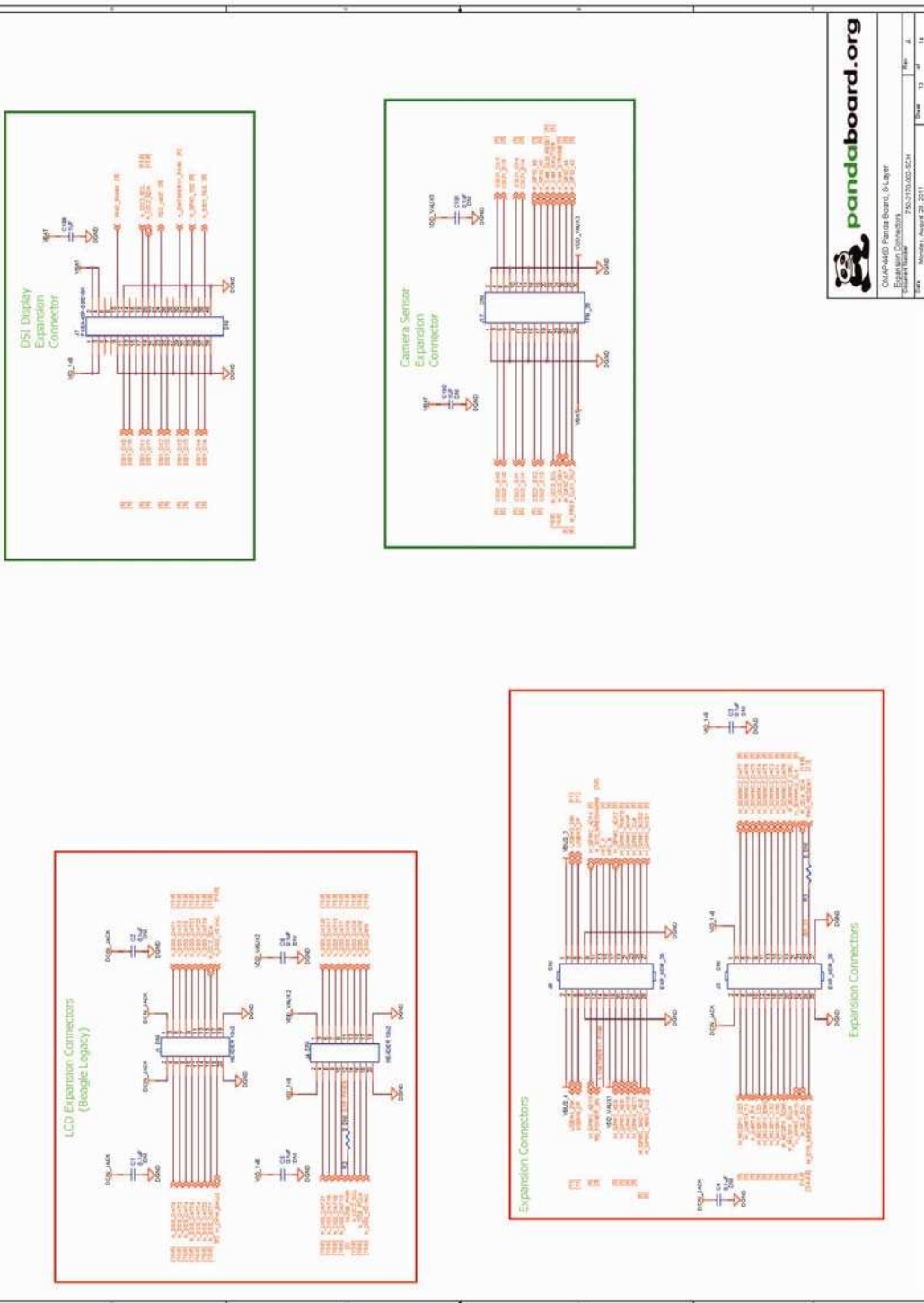

pandaboard.org

Doc: OMAP Pandaboard ES Layer 1
 Doc: OMAP Pandaboard ES Layer 2
 Doc: OMAP Pandaboard ES Layer 3
 Doc: OMAP Pandaboard ES Layer 4
 Doc: OMAP Pandaboard ES Layer 5
 Doc: OMAP Pandaboard ES Layer 6
 Doc: OMAP Pandaboard ES Layer 7
 Doc: OMAP Pandaboard ES Layer 8
 Doc: OMAP Pandaboard ES Layer 9
 Doc: OMAP Pandaboard ES Layer 10
 Doc: OMAP Pandaboard ES Layer 11
 Doc: OMAP Pandaboard ES Layer 12
 Doc: OMAP Pandaboard ES Layer 13
 Doc: OMAP Pandaboard ES Layer 14
 Doc: OMAP Pandaboard ES Layer 15
 Doc: OMAP Pandaboard ES Layer 16
 Doc: OMAP Pandaboard ES Layer 17
 Doc: OMAP Pandaboard ES Layer 18
 Doc: OMAP Pandaboard ES Layer 19
 Doc: OMAP Pandaboard ES Layer 20
 Doc: OMAP Pandaboard ES Layer 21
 Doc: OMAP Pandaboard ES Layer 22
 Doc: OMAP Pandaboard ES Layer 23
 Doc: OMAP Pandaboard ES Layer 24
 Doc: OMAP Pandaboard ES Layer 25
 Doc: OMAP Pandaboard ES Layer 26
 Doc: OMAP Pandaboard ES Layer 27
 Doc: OMAP Pandaboard ES Layer 28
 Doc: OMAP Pandaboard ES Layer 29
 Doc: OMAP Pandaboard ES Layer 30
 Doc: OMAP Pandaboard ES Layer 31
 Doc: OMAP Pandaboard ES Layer 32
 Doc: OMAP Pandaboard ES Layer 33
 Doc: OMAP Pandaboard ES Layer 34
 Doc: OMAP Pandaboard ES Layer 35
 Doc: OMAP Pandaboard ES Layer 36
 Doc: OMAP Pandaboard ES Layer 37
 Doc: OMAP Pandaboard ES Layer 38
 Doc: OMAP Pandaboard ES Layer 39
 Doc: OMAP Pandaboard ES Layer 40
 Doc: OMAP Pandaboard ES Layer 41
 Doc: OMAP Pandaboard ES Layer 42
 Doc: OMAP Pandaboard ES Layer 43
 Doc: OMAP Pandaboard ES Layer 44
 Doc: OMAP Pandaboard ES Layer 45
 Doc: OMAP Pandaboard ES Layer 46
 Doc: OMAP Pandaboard ES Layer 47
 Doc: OMAP Pandaboard ES Layer 48
 Doc: OMAP Pandaboard ES Layer 49
 Doc: OMAP Pandaboard ES Layer 50
 Doc: OMAP Pandaboard ES Layer 51
 Doc: OMAP Pandaboard ES Layer 52
 Doc: OMAP Pandaboard ES Layer 53
 Doc: OMAP Pandaboard ES Layer 54
 Doc: OMAP Pandaboard ES Layer 55
 Doc: OMAP Pandaboard ES Layer 56
 Doc: OMAP Pandaboard ES Layer 57
 Doc: OMAP Pandaboard ES Layer 58
 Doc: OMAP Pandaboard ES Layer 59
 Doc: OMAP Pandaboard ES Layer 60
 Doc: OMAP Pandaboard ES Layer 61
 Doc: OMAP Pandaboard ES Layer 62
 Doc: OMAP Pandaboard ES Layer 63
 Doc: OMAP Pandaboard ES Layer 64
 Doc: OMAP Pandaboard ES Layer 65
 Doc: OMAP Pandaboard ES Layer 66
 Doc: OMAP Pandaboard ES Layer 67
 Doc: OMAP Pandaboard ES Layer 68
 Doc: OMAP Pandaboard ES Layer 69
 Doc: OMAP Pandaboard ES Layer 70
 Doc: OMAP Pandaboard ES Layer 71
 Doc: OMAP Pandaboard ES Layer 72
 Doc: OMAP Pandaboard ES Layer 73
 Doc: OMAP Pandaboard ES Layer 74
 Doc: OMAP Pandaboard ES Layer 75
 Doc: OMAP Pandaboard ES Layer 76
 Doc: OMAP Pandaboard ES Layer 77
 Doc: OMAP Pandaboard ES Layer 78
 Doc: OMAP Pandaboard ES Layer 79
 Doc: OMAP Pandaboard ES Layer 80
 Doc: OMAP Pandaboard ES Layer 81
 Doc: OMAP Pandaboard ES Layer 82
 Doc: OMAP Pandaboard ES Layer 83
 Doc: OMAP Pandaboard ES Layer 84
 Doc: OMAP Pandaboard ES Layer 85
 Doc: OMAP Pandaboard ES Layer 86
 Doc: OMAP Pandaboard ES Layer 87
 Doc: OMAP Pandaboard ES Layer 88
 Doc: OMAP Pandaboard ES Layer 89
 Doc: OMAP Pandaboard ES Layer 90
 Doc: OMAP Pandaboard ES Layer 91
 Doc: OMAP Pandaboard ES Layer 92
 Doc: OMAP Pandaboard ES Layer 93
 Doc: OMAP Pandaboard ES Layer 94
 Doc: OMAP Pandaboard ES Layer 95
 Doc: OMAP Pandaboard ES Layer 96
 Doc: OMAP Pandaboard ES Layer 97
 Doc: OMAP Pandaboard ES Layer 98
 Doc: OMAP Pandaboard ES Layer 99
 Doc: OMAP Pandaboard ES Layer 100



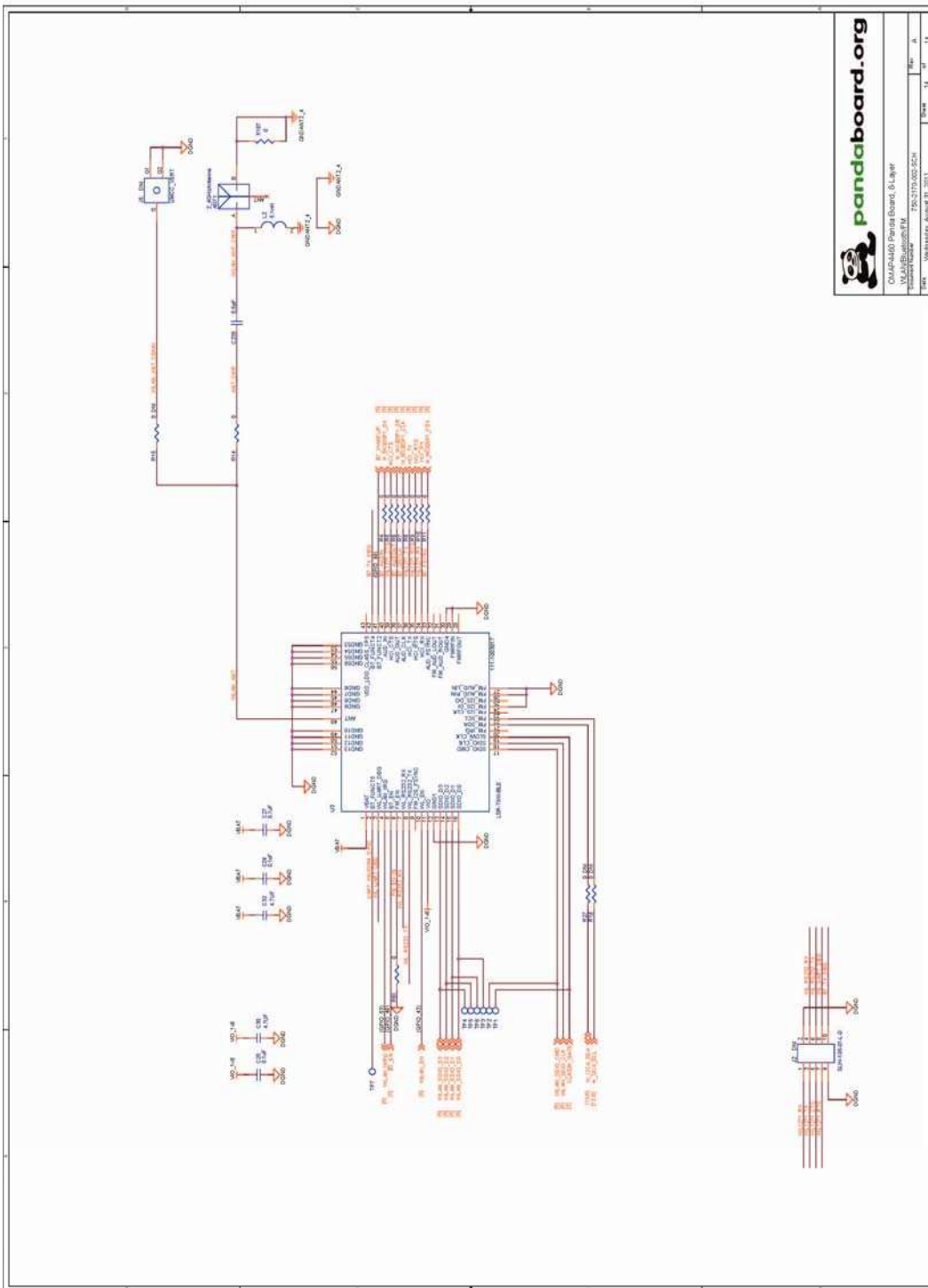

pandaboard.org

OMAP4460 Pandaboard ES Layer
 Model Number: P20-21054-02-01
 Date: 2011-09-29

Rev	A
Rev	1
Rev	1
Rev	1



4.5 Pandaboard ES Bill of Materials

The Bill of Material for the OMAP4460 Pandaboard ES is provided at the following location:

<http://Pandaboard.org/content/resources/references>

*These design materials are ***NOT SUPPORTED*** and **DO NOT** constitute a reference design. Only “community” support is allowed via resources at <http://Pandaboard.org/content/community/home>. **THERE IS NO WARRANTY FOR THE DESIGN MATERIALS, TO THE EXTENT PERMITTED BY APPLICABLE LAW. EXCEPT WHEN OTHERWISE STATED IN WRITING THE COPYRIGHT HOLDERS AND/OR OTHER PARTIES PROVIDE THE DESIGN MATERIALS “AS IS” WITHOUT WARRANTY OF ANY KIND, EITHER EXPRESSED OR IMPLIED, INCLUDING, BUT NOT LIMITED TO, THE IMPLIED WARRANTIES OF MERCHANTABILITY AND FITNESS FOR A PARTICULAR PURPOSE. THE ENTIRE RISK AS TO THE QUALITY AND PERFORMANCE OF THE DESIGN MATERIALS IS WITH YOU. SHOULD THE DESIGN MATERIALS PROVE DEFECTIVE, YOU ASSUME THE COST OF ALL NECESSARY SERVICING, REPAIR OR CORRECTION.***

We mean it; these design materials may be totally unsuitable for any purposes.

4.6 Pandaboard ES PCB Design Information

The PCB Design information (including the Cadence Allegro 16.3 Board file (.brd file) and PCB Gerber design files) are provided at the following location:

<http://Pandaboard.org/content/resources/references>

*These design materials are ***NOT SUPPORTED*** and **DO NOT** constitute a reference design. Only “community” support is allowed via resources at <http://Pandaboard.org/content/community/home>. **THERE IS NO WARRANTY FOR THE DESIGN MATERIALS, TO THE EXTENT PERMITTED BY APPLICABLE LAW. EXCEPT WHEN OTHERWISE STATED IN WRITING THE COPYRIGHT HOLDERS AND/OR OTHER PARTIES PROVIDE THE DESIGN MATERIALS “AS IS” WITHOUT WARRANTY OF ANY KIND, EITHER EXPRESSED OR IMPLIED, INCLUDING, BUT NOT LIMITED TO, THE IMPLIED WARRANTIES OF MERCHANTABILITY AND FITNESS FOR A PARTICULAR PURPOSE. THE ENTIRE RISK AS TO THE QUALITY AND PERFORMANCE OF THE DESIGN MATERIALS IS WITH YOU. SHOULD THE DESIGN MATERIALS PROVE DEFECTIVE, YOU ASSUME THE COST OF ALL NECESSARY SERVICING, REPAIR OR CORRECTION.***

We mean it; these design materials may be totally unsuitable for any purposes.