



Low Voltage CMOS Driver Circuit

Features

- Four low resistance output drivers for bipolar or unipolar watch stepping motors.
- Low transversal transition current.
- Very low current consumption: 0.1 μ A at 25°C.
- Two different output resistances programmable by metal mask.
- Wide power supply voltage range: 1.1 to 3.5 V.
- Tristate input for applications as fast bus driver.
- ESD and latch-up protections on input and output pads.

Description

The EM5060 (previously named H5060) is a low power integrated circuit in HCMOS Silicon Gate Technology designed to drive bipolar or unipolar stepping motors. This device contains four identical and independent non-inverting circuits which can be connected by metal mask programming so as to obtain two identical non-inverting circuits with a lower resistance output. Each buffer is driven by a special cell which dephases the P and N transistor signal input, for a minimization of the transversal transition current. A tristate input HIZ, with internal pulldown resistor provides the high impedance state of the four outputs.

Application

- Motor driver for watch/clock application
- Bus drivers
- LED driver

Functional Diagram

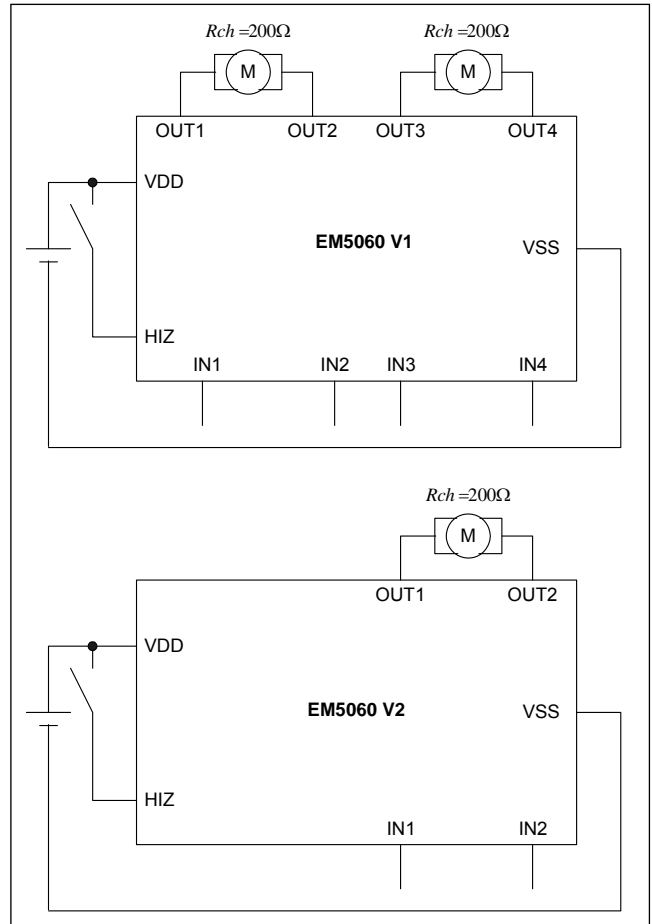

Fig. 1

Pin Assignment

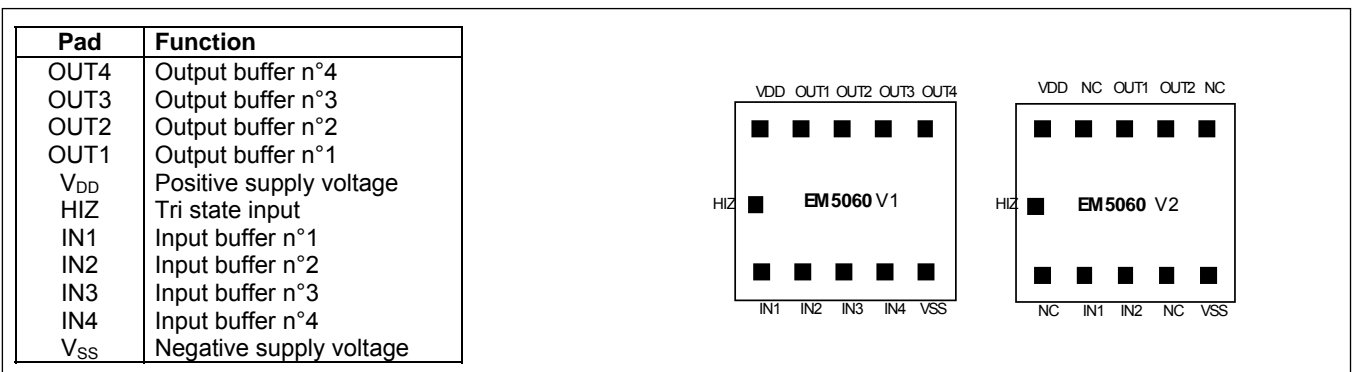

Fig. 2



EM5060

Absolute Maximum Ratings

Parameter	Symbol	Min	Typ	Max	Unit
Supply Voltage	V _{DD}	-0.3		5.5	V
Voltage at remaining pin	V _{pin}	V _{SS} -0.3		V _{DD} +0.3	V
Storage temperature	T _{store}	-55		+120	°C

Table 1

Stresses above these listed maximum ratings may cause permanent damage to the device. Exposure to conditions beyond specified electrical characteristics may affect device reliability or cause malfunction.

Recommended Operating Conditions

Parameter	Symbol	Value	Units
Ambient temperature	T	25	°C
Motor resistance	R _{ch}	200	Ohms
Positive supply	V _{DD}	1.55	V
Negative supply	V _{SS}	0.0	V
Supply source resistance	R _i	10	Ohms

Table 2

Handling Procedures

This device contains circuitry to protect the terminals against damage due to high static voltages or electrical fields. However, it is advised that normal precautions be taken to avoid application of any voltage higher than minimum rated voltages to this circuit.

Operating Conditions

Parameter	Symbol	Min	Typ	Max	Units
Operating temperature	T _{opr}	-20		+70	°C

Table 3

Electrical and Switching Characteristics

at recommended operating conditions (valid unless otherwise specified)

Parameter	Symbol	Conditions	Min.	Typ.	Max.	Unit
Supply voltage	V _{DD}	Operating	1.1	1.55	3.5	V
Standby current		I _{mot} = 0 IN1, IN2, IN3, IN4 at V _{DD} or V _{SS} HIZ at V _{SS} or open			100	nA
Inputs						
Pulse width	t _{WL} t _{WH}	V _{DD} = 1.2 V V _{IL} = V _{SS} V _{IH} = V _{DD}	1 1			ms ms
Voltage	V _{IL} V _{IH}	Overall voltage range	V _{DD} -0.3	V _{SS} V _{DD}	0.4	V V
HIZ Input Current	I _{HIZ}	HIZ at V _{DD}	0.5	2	5	µA
Outputs						
Motor Output Current	I _{OUT}	R _{ch} = 200 Ω, V _{DD} = 1.2 V Version V1 Version V2 V _{DD} = 1.50 V Version V1 Version V2 V _{DD} = 3.0 V Version V1 Version V2	±4.3 ±4.8	±5.0		mA mA
			±6.0 ±6.4	±6.6		mA mA
			±13.0 ±13.3	±13.5		mA mA
Timing Characteristics						
Propagation delay	t _{PHL} t _{PLH}	V _{DD} = 1.2 V, CL = 30pF V _{DD} = 1.2 V, CL = 30pF		5 5	100 100	µs µs
Transition time	t _{THL} t _{TLH}	V _{DD} = 1.2 V, CL = 30pF V _{DD} = 1.2 V, CL = 30pF		3 3	100 100	µs µs

Table 4

Timing Waveforms

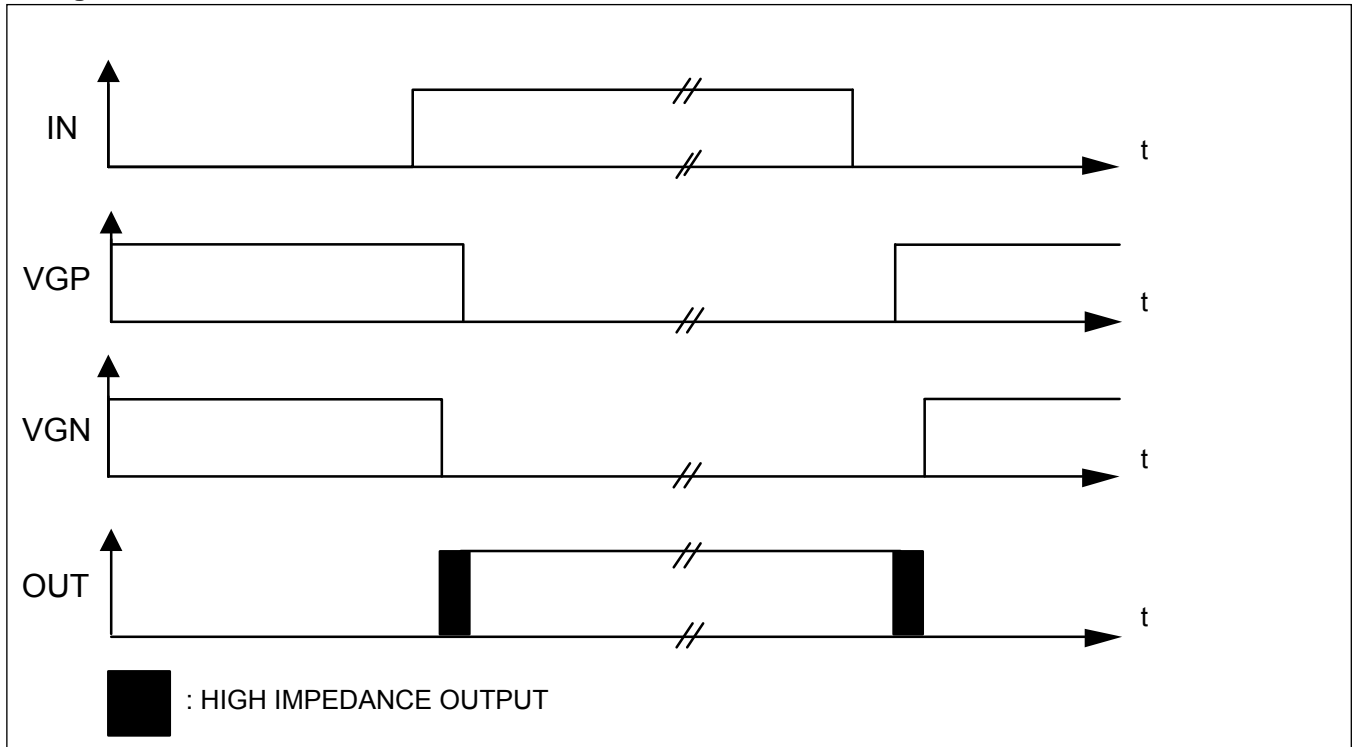

Fig. 3

Block Diagram

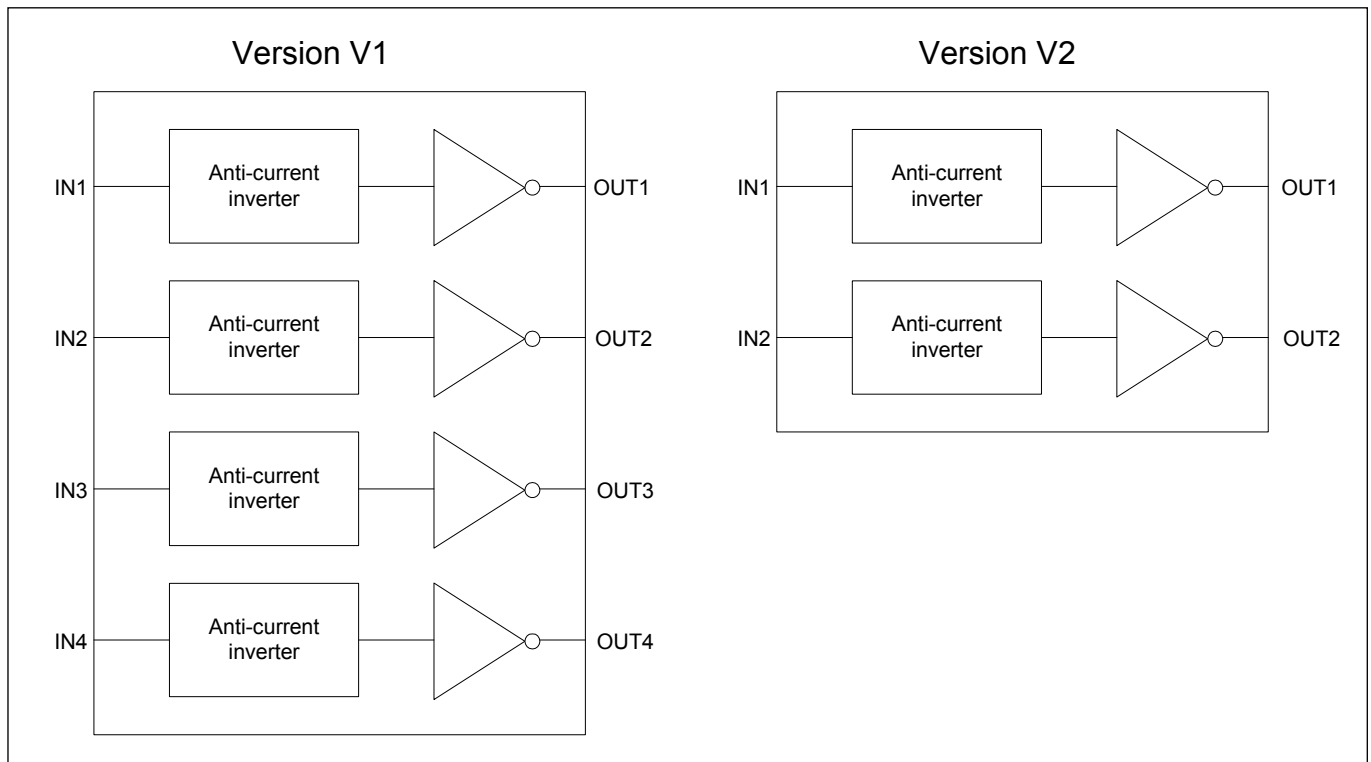

Fig. 4

Functional Description

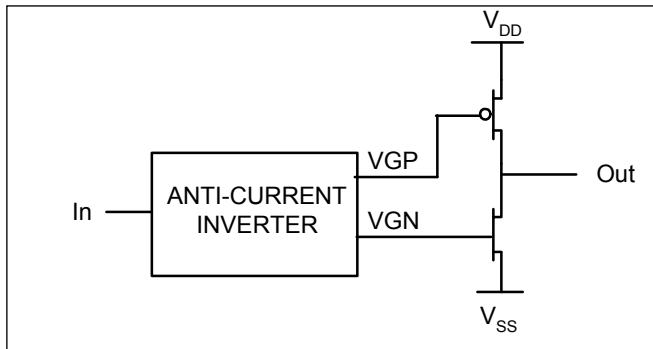

Fig. 5

Chip Information

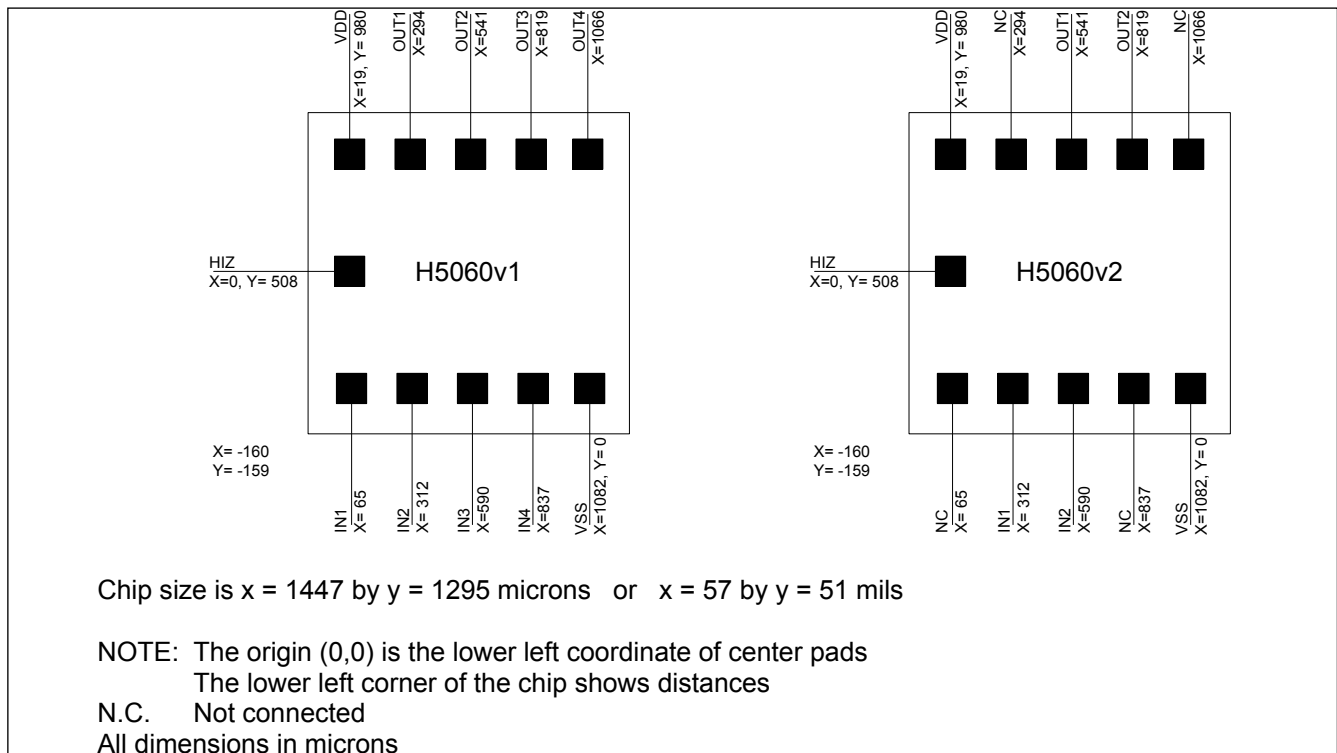

Fig. 6

Ordering Information

EM5060 is available in two versions:

- Version **V1** contains four input/outputs (INPUTS = IN1, IN2, IN3, IN4 ; OUTPUTS = OUT1, OUT2, OUT3, OUT4).
- Version **V2** contains two input/outputs (INPUTS = IN1, IN2 ; OUTPUTS = OUT1, OUT2).

When ordering, please specify the complete Part Number below.

Part Number	Version	Die & Delivery Form
EM5060V1WV11	V1	Die in waffle pack, 11 mils thickness
EM5060V1WS11	V1	Sawn wafer, 11 mils thickness
EM5060V2WV11	V2	Die in waffle pack, 11 mils thickness
EM5060V2WS11	V2	Sawn wafer, 11 mils thickness

EM Microelectronic-Marín SA (EM) makes no warranty for the use of its products, other than those expressly contained in the Company's standard warranty which is detailed in EM's General Terms of Sale located on the Company's web site. EM assumes no responsibility for any errors which may appear in this document, reserves the right to change devices or specifications detailed herein at any time without notice, and does not make any commitment to update the information contained herein. No licenses to patents or other intellectual property of EM are granted in connection with the sale of EM products, expressly or by implications. EM's products are not authorized for use as components in life support devices or systems.