



8bit Flash MCU, 10bit ADC, E²PROM, 5V

Description

The EM6819FX-B300 is designed to be battery operated for extended lifetime applications. Its large voltage range from 5V down to 2V makes it a perfect match for today's demanding applications. Brownout and powercheck functions ensure reliable operation at or near undervoltage conditions, offering greater reliability in complex operation modes. Each of the 24 I/Os are freely programmable and the microcontroller has a dual quartz and trimmable RC oscillator up to 15MHz. It has an 8-bit RISC architecture specially designed for very low power consumption. With 2 clocks per instruction, the EM6819FX-B300 executes up to 7.5 MIPS at 15MHz and achieves astonishing 4000 MIPS/Watt.

Power Management Features for Low-Power application

- ❑ Sleep current 400 nA, typ
- ❑ True low current: typ 126uA at 3V, 1 MIPS
- ❑ 800 nA with RTC
- ❑ Idle : CPU off, Peripherals on, Currents Down to 770 nA
- ❑ Run : CPU on, Peripherals on, Currents Down to 2 uA

Features

- ❑ Wide supply voltage range 2V – 5V
- ❑ Up to 7.5 MIPS at 15MHz
- ❑ On-chip brownout detection
- ❑ PowerCheck functions at start-up
- ❑ 32 Voltage Level Detection on Supply or Input pin
- ❑ 3 terminal Operational Amplifier / Comparator
- ❑ ADC 10-bit, 8 channel
- ❑ Temperature sensor
- ❑ Voltage reference input/output
- ❑ Fast wake-up
- ❑ Up to 24 fully configurable I/Os
- ❑ Flash read monitoring system
- ❑ Dual clock mode, quartz and RC oscillators:
 - 2 MHz – 15MHz RC, pre-trimmed
 - Low freq RC Oscillator (8kHz)
 - 32768 Hz Xtal, 4MHz Resonator, Ext Clock
- ❑ 8-bit CoolRISC architecture
 - 16 registers
 - 8*8bit hardware multiplier
- ❑ Power-On-Reset and watchdog
- ❑ GPNVM Memory
 - Sharing Instruction code and data
- ❑ Fully static 512 Byte RAM
- ❑ Internal and external interrupts
- ❑ Frequency generator
- ❑ 4 independent PWM outputs
- ❑ 8/16-bit timers
- ❑ Prescaler for RC and XTAL
- ❑ SPI interface
- ❑ Small size, Green mold / lead-free packages

Architecture

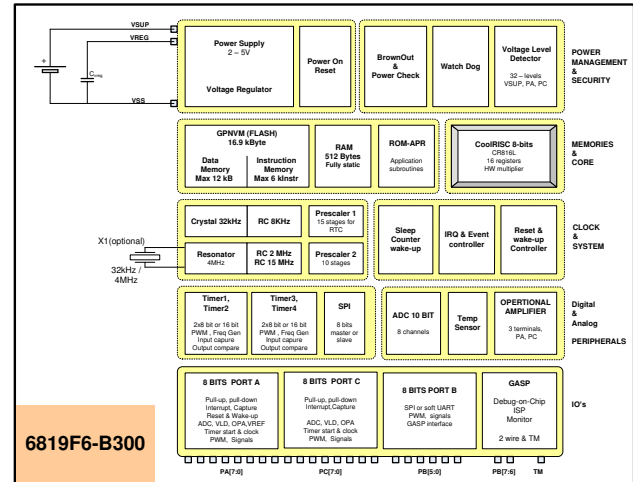

Pinout 20 lead QFN

Others include, TSSOP16/20/28

20 Lead QFN
4x4mm body
EM6819FX-BXXX

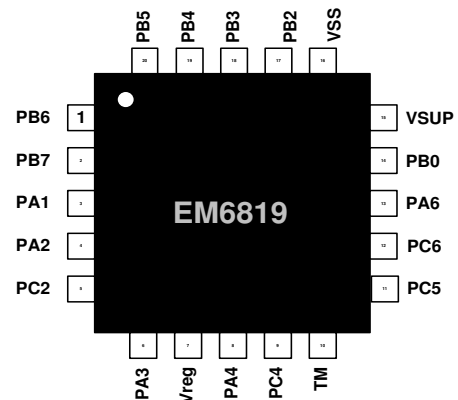

Typical Applications

- ❑ Metering
- ❑ Safety and Security devices
- ❑ Heat Cost Allocation
- ❑ Sensor Interfaces, Smoke detector
- ❑ Security
- ❑ Body care
- ❑ Sports
- ❑ Computer peripherals, Bluetooth chipset
- ❑ Wireless

Tools & Services

- ❑ On chip debug system in the application
- ❑ ISP (In-system) programming
- ❑ C-compiler
- ❑ Windows-based software programs
- ❑ Programmer from different vendors
- ❑ Dedicated team of engineers for outstanding support

Power supply

- Low power architecture
- Voltage regulator for internal logic supply
- External regulator capacitor

CPU

- 8-bit CoolRisc 816L Core
- 16 internal registers
- 4 hardware subroutine stacks
- 8-bit hardware multiplier

Flash/EEPROM

- 16.9k Byte shared General Purpose Non Volatile Flash memory
- max 6k Instructions program memory
- max 12 kByte non volatile data memory

RAM

- 512 x 8-bit static SRAM
- 48 byte of Ram-cache for EEPROM modification support

Operating modes

- Active mode: CPU and peripherals are running
- Standby mode: CPU halted, peripherals on
- Sleep mode: no clocks, data retained

Resets

- Power On Reset
- Reset from logic watchdog
- Brown out (as voltage supervisory function)
- Reset with Port A selection
- Flags to identify the reset source

Watchdog timer

- generation of watchdog reset after time out
- independent low frequency watchdog oscillator

Oscillator RC

- internal RC oscillator, 2MHz and 15MHz pre-trimmed
- internal 8 KHz RC Oscillator

External Oscillator

- 32 KHz watch type Crystal or 4MHz Resonator

Prescaler's

- Two clock prescalers (dividers) for the peripheral clock generation:
 - Prescaler 1 is a 15-stage divider
 - Prescaler 2 is a 10-stage divider
- input clock software selectable
- fix intervall IRQ's

Interrupt

- external IRQ's from Port A, VLD, Comparator
- internal IRQ's from Timer, Prescaler, ADC, SPI
- Event from SPI/ADC and DoC

VLD

- Detection of 32 voltage levels, internal reference
- Comparison against VSUP, input Pin or Op.Amp output

Parallel In/Output Port A, Port C

- 8-bit wide direct input read
- all functions bit-wise configurable
 - Input , output
 - Debouncer, IRQ on pos. or neg. edge
 - Input combination reset
 - Pullup, pulldown or nopull selectable
 - Freq. Input for timer
 - Analog In/Out

Parallel In/Output Port B

- 8 multipurpose I/O's
- 8-bit wide direct input read
- CMOS or Nch. Open Drain outputs
- all functions bit-wise configurable
 - Input , output
 - Pullup, pulldown or nopull selectable
 - CMOS or Nch. Open Drain outputs

Serial Port Interface SPI

- 3 wire serial Interface, Sclk, Sin, Sout
- master and Slave mode
- Serial datastream output
- Event / IRQ
- Mapped on port outputs

Timer (4 x 8-bit, or 2 x 16-bit)

- 8 (16) bit wide, Zero Stop and Auto Reload mode
- External signal pulse width measurement
- PWM generation, IRQ
- Event Counter
- Input capture
- Output compare

Sleep Counter Wake-up (SCWUP)

- Automatically wakes up the circuit from sleep mode
- Enable/disable by register

Op. Amplifier / Comparator

- All 3 terminals mapped on PortA/PortC
- Output routed to VLD cell
- Amplifier or Comparator output

Temp. Sensor

- Fully internal temperature sensor
- Multiplexed input to ADC

Brown Out

- On-chip Brown-Out detection, reset state
- Power check at Startup

ADC

- 10-bit, 8 channels ADC
- Single or Continuous mode
- External/internal reference voltage available on a pad
- Event / IRQ

DoC (Debug on Chip)

- 2 wire serial interface debug and programming interface
- Flash programming
- Event / IRQ



Pin Name	Software selectable functions	Remarks
PA0	Input with pullup/pulldown, IRQ capability, CPU read, wake-up, timer1 ext clock. Output of CPU write and a selection of internal clock and PWM signals. Analog input for ADC.	
PA1	Input with pullup/pulldown, IRQ capability, CPU read, wake-up, timer2 ext clock. Output of CPU write, selection of internal clock and PWM signals . Analog: input for ADC and VLD; Output for OPAMP.	
PA2	Input with pullup/pulldown, IRQ capability, CPU read, wake-up, serial data input, timer3 ext clock. Output of CPU write, serial data out and selection of internal clock and PWM signals Analog: input for ADC,VLD and Opamp;	
PA3	Input with pullup/pulldown, IRQ capability, CPU read, wake-up, serial data input, timer4 ext clock. Output of CPU write, serial data out and selection of internal clock and PWM signals Analog: input for ADC,VLD and Opamp;	
PA4	Input with pullup/pulldown, IRQ capability, CPU read, wake-up, serial data. Output of CPU write and a selection of internal clock and PWM signals. Analog: XTAL/Resonator connection.	
PA5	Input with pullup/pulldown, IRQ capability, CPU read, wake-up. Output of CPU write and a selection of internal clock and PWM signals.	
PA6	Input with pullup/pulldown, IRQ capability, CPU read, wake-up, serial clock.. Output of CPU write, serial clock and a selection of internal clock and PWM signals. Analog: input for VLD ; Output for VBGp	
PA7	Input with pullup/pulldown, IRQ capability, CPU read, wake-up, serial clock.. Output of CPU write, serial data and a selection of internal clock and PWM signals. Analog: input for VLD ; Output for internal reference voltage	
PB0	Input with pullup/pulldown, CPU read, serial data. Output of CPU write and a selection of internal clock and PWM signals.	
PB1	Input with pullup/pulldown, CPU read. Output of CPU write and a selection of internal clock and PWM signals.	
PB2	Input with pullup/pulldown, CPU read, serial clock. Output of CPU write, serial clock and a selection of internal clock and PWM signals.	
PB3	Input with pullup/pulldown, CPU read. Output of CPU write and a selection of internal clock and PWM signals.	
PB4	Input with pullup/pulldown, CPU read. Output of CPU write, serial data and a selection of internal clock and PWM signals.	
PB5	Input with pullup/pulldown, CPU read. Output of CPU write and a selection of internal clock and PWM signals.	
PB6	Input with pullup/pulldown, CPU read. Output of CPU write and a selection of internal clock and PWM signals.	GASP clock
PB7	Input with pullup/pulldown, CPU read. Output of CPU write and a selection of internal clock and PWM signals.	GASP data
PC0	Input with pullup/pulldown, IRQ capability, CPU read, timer1 ext clock. Output of CPU write and a selection of internal clock and PWM signals. Analog input for ADC.	
PC1	Input with pullup/pulldown, IRQ capability, CPU read, timer2 ext clock. Output of CPU write, selection of internal clock and PWM signals . Analog: input for ADC and VLD; Output for OPAMP.	
PC2	Input with pullup/pulldown, IRQ capability, CPU read.	



	Output of CPU write, serial data, selection of internal clock and PWM signals . Analog: input for ADC and OPAMP.	
PC3	Input with pullup/pulldown, IRQ capability, CPU read, timer4 ext clock. Output of CPU write, selection of internal clock and PWM signals . Analog: input for ADC and OPAMP.	
PC4	Input with pullup/pulldown, IRQ capability, CPU read, external clock input Output of CPU write, selection of internal clock and PWM signals . Analog: XTAL/Resonator connection	
PC5	Input with pullup/pulldown, IRQ capability, CPU read. Output of CPU write, selection of internal clock and PWM signals . Analog: input for VLD.	
PC6	Input with pullup/pulldown, IRQ capability, CPU read, serial clock, timer1 ext clock Output of CPU write, serial clock, selection of internal clock and PWM signals . Analog: input for VLD.	
PC7	Input with pullup/pulldown, IRQ capability, CPU read, timer3 ext clock Output of CPU write, selection of internal clock and PWM signals .	
TM	GASP mode entry	GASP mode
VREG	External Capacitance to maintain internal regulated voltage	
VSUP	Main power supply pin.	
VSS	Main GND. This is also the circuit substrate potential.	



TABLE OF CONTENTS

1. EM6819 FAMILY (INCLUDING EM6819FX-B300)	10
2. SYSTEM OVERVIEW	11
2.1 OPERATING MODES	12
2.1.1 <i>Active mode</i>	12
2.2 LOW POWER MODES	12
2.2.1 <i>Standby mode</i>	12
2.2.2 <i>Sleep mode</i>	13
2.2.3 <i>Sleep Wake-up</i>	13
2.2.4 <i>Operation mode registers</i>	14
2.3 REGISTER TYPES	15
2.4 POWER MANAGEMENT	16
2.4.1 <i>Brownout</i>	16
2.4.2 <i>Powercheck</i>	16
2.4.3 <i>POR</i>	16
2.4.4 <i>Powermanagement Registers</i>	17
2.5 REGISTER MAP	18
2.6 PORT TERMINAL CONNECTION REFERENCE TABLE	24
2.7 AVAILABLE PACKAGES	25
3. CPU CORE CR816	26
3.1 PM_MISS FUNCTION (FLASH READ MONITOR)	26
4. NVM MEMORY	27
4.1 INTRODUCTION	27
4.2 NVM ARCHITECTURE	27
4.3 RAM CACHE	28
4.4 WRITE DATA IN NVM	28
4.4.1 <i>Row and sector selection</i>	28
4.4.2 <i>Fast/slow operation</i>	28
4.4.3 <i>Erase</i>	29
4.4.4 <i>Write</i>	29
4.5 ROW 61 SECTOR 5	30
4.6 ROW 62 SECTOR 5	30
4.6.1 <i>Temperature tolerance</i>	30
4.7 ROW 63 SECTOR 5	31
4.8 READ DATA IN NVM	32
4.9 ROW TO CACHE	32
4.9.1 <i>NVM configuration registers</i>	33
5. CRC CHECK	34
5.1 CRC CHECK ON PROGRAM AREA	34
5.2 CRC CHECK ON DATA AREA	34
6. ROM API ROUTINES	35
6.1 BOOT SEQUENCE	35
6.2 SUB-ROUTINES USED FOR APPLICATION	36
7. RAM	37
8. RESET CONTROLLER	38
8.1 RESET SOURCES	38
8.2 RESET SIGNALS	38
8.2.1 <i>POR</i>	38
8.2.2 <i>ResAna</i>	38
8.2.3 <i>ResSys</i>	38
8.2.4 <i>Reset Flags</i>	38
8.3 RESET REGISTERS	39
9. OSCILLATOR AND CLOCKING STRUCTURE	40
9.1 EXTERNAL CLOCK SELECTION	41

9.2	INTERNAL HIGH AND LOW FREQUENCY CLOCK SELECTION	41
9.2.1	<i>External clock selection Restrictions</i>	42
9.2.2	<i>CPU Clock selection</i>	42
9.2.3	<i>Prescaler1 Clock selection</i>	43
9.2.4	<i>Prescaler2 Clock selection</i>	43
9.3	CLOCK CONTROL	44
9.4	OSCILLATORS CONTROL	45
9.5	CLOCK CONTROL REGISTERS	47
10.	PRESCALER1	49
10.1	PRESCALER1 CLOCK SELECTION	49
10.2	PRESCALER1 RESET	50
10.3	PRESCALER1 REGISTERS	50
11.	PRESCALER2	51
11.1	PRESCALER2 CLOCK SELECTION	51
11.2	PRESCALER2 RESET	51
11.3	PRESCALER2 REGISTERS	51
12.	INTERRUPT AND EVENT CONTROLLER	52
12.1	INTERRUPTS GENERAL	52
12.1.1	<i>Basic features</i>	52
12.2	INTERRUPT ACQUISITION	53
12.3	INTERRUPTS FROM IO PORTS	54
12.4	INTERRUPT ACQUISITION MASKING.	54
12.4.1	<i>Pre and Postmasking of interrupts</i>	54
12.5	INTERRUPT ACQUISITION CLEARING	55
12.5.1	<i>Software Interrupt acquisition set</i>	55
12.6	INTERRUPT REGISTERS	55
12.7	EVENT GENERAL	58
12.7.1	<i>Basic features</i>	58
12.8	EVENT ACQUISITION	58
12.9	EVENT MASKING	59
12.10	EVENT ACQUISITION CLEARING	60
12.11	SOFTWARE EVENT SETTING	60
12.12	EVENT REGISTERS	60
13.	CPU INTERRUPT AND EVENT HANDLING	61
13.1	INTERRUPT PRIORITY	61
13.2	CPU STATUS REGISTER	62
13.3	CPU STATUS REGISTER PIPELINE EXCEPTION	62
13.4	PROCESSOR VECTOR TABLE	63
13.5	CONTEXT SAVING	63
14.	PORT A	64
14.1	PORT A TERMINAL MAPPING	64
14.2	PORT A IO OPERATION	65
14.3	OUTPUT SIGNALS ON PORT A	67
14.4	PORT A DEBOUNCER	68
14.5	PORT A INTERRUPT GENERATION	68
14.5.1	<i>PA Irq in Active and Standby mode</i>	68
14.5.2	<i>PA Irq in Sleep Mode</i>	68
14.6	PORT A RESET FUNCTION	68
14.7	PORT A REGISTERS	69
15.	PORT B	71
15.1	PORT B TERMINAL MAPPING	71
15.2	PORT B IO OPERATION	71
15.2.1	<i>Gasp communication on PB7, PB6</i>	72
15.3	OUTPUT SIGNALS ON PORT B	73
15.4	PORT B REGISTERS	74
16.	PORT C	75

16.1	PORT C TERMINAL MAPPING	75
16.2	PORT C IO OPERATION	75
16.3	OUTPUT SIGNALS ON PORT C	77
16.4	PORT C DEBOUNCER	78
16.5	PORT C INTERRUPT GENERATION	78
16.5.1	<i>PC Irq in Active and Standby mode</i>	78
16.5.2	<i>PC Irq in Sleep Mode</i>	78
16.6	PORT C REGISTERS	79
17.	TIMERS	81
17.1	TIMER CHAINING	81
17.2	TIMER CLOCK SOURCES	82
17.3	TIMER START	83
17.3.1	<i>Software start - Stop</i>	83
17.3.2	<i>Hardware Start – Stop (period counting)</i>	83
17.3.3	<i>Hardware Start – Stop (puls counting)</i>	84
17.4	AUTO-RELOAD MODE	85
17.5	AUTO-STOP MODE	85
17.6	TIMER INPUT CAPTURE	86
	OUTPUT COMPARE	88
17.7	OUTPUT COMPARE - <i>PWMX</i> SIGNAL PORT MAPPING	89
17.8	TIMER INTERRUPTS	90
17.9	TIMER REGISTERS	90
18.	SPI – SERIAL INTERFACE	94
18.1	SCLK - SPI MASTER/ SLAVE MODE AND CLOCK SELECTION	95
18.2	SIN PORT MAPPING	96
18.3	SOUT PORT MAPPING	96
18.4	SPI START – STOP	96
18.5	AUTO-START	96
18.6	RTZ POSITIVE EDGE TRANSMISSION SPICOMPMode = 0	97
18.7	RTO POSITIVE EDGE TRANSMISSION SPICOMPMode = 0	97
18.8	RTZ NEGATIVE EDGE TRANSMISSION SPICOMPMode = 0	97
18.9	RTO NEGATIVE EDGE TRANSMISSION SPICOMPMode = 0	98
18.10	RTZ POSITIVE EDGE TRANSMISSION SPICOMPMode = 1	98
18.11	RTO POSITIVE EDGE TRANSMISSION SPICOMPMode = 1	98
18.12	RTZ NEGATIVE EDGE TRANSMISSION SPICOMPMode = 1	99
18.13	RTO NEGATIVE EDGE TRANSMISSION SPICOMPMode = 1	99
18.14	SPI REGISTERS	100
19.	WATCHDOG	101
19.1	WATCHDOG CLEAR	101
19.2	WATCHDOG DISABLING	101
19.3	WATCHDOG REGISTERS	102
20.	SLEEP COUNTER WAKE-UP	103
20.1	SC WAKE-UP ENABLING	103
20.2	SC WAKE-UP DISABLING	103
20.3	SC WAKE-UP REGISTERS	104
21.	10-BITS ADC	105
21.1	CONDITIONER	105
21.1.1	<i>Range selection</i>	105
21.1.2	<i>Reference selection</i>	106
21.1.3	<i>Analog input selection</i>	106
21.2	ADC OFFSET TRIM SELECTION	107
21.3	ADC CONFIGURATIONS	108
21.3.1	<i>Running mode</i>	108
21.3.2	<i>ADC enabling</i>	108
21.3.3	<i>ADC sampling rate</i>	109
21.3.4	<i>Low noise mode</i>	109
21.3.5	<i>8bit ADC selection</i>	109

21.4	ADC ACQUISITION SEQUENCE	110
21.5	ADC REGISTERS	110
22.	TEMPERATURE SENSOR	111
22.1	TEMPERATURE SENSOR ENABLING	111
22.2	TEMPERATURE SENSOR REGISTERS	111
23.	BAND GAP	112
23.1	BAND GAP REGISTER	112
24.	VLD	113
24.1	VLD SOURCE AND LEVEL SELECTION	113
24.2	VLD ENABLE	113
24.3	VLD RESULT	113
24.4	VLD INTERRUPT	114
24.5	VLD TRIMMING	114
24.6	VLD REGISTERS	114
25.	RC OSCILLATOR	115
25.1	RC OSCILLATORS REGISTERS	115
26.	XTAL OSCILLATOR 32KHZ	116
27.	RESONATOR 4MHZ	117
28.	8KHZ OSCILLATOR	118
29.	ANALOG OPAMP	119
29.1	SELECT OPAMP/COMPARATOR	119
29.2	OPAMP SUPPLY	119
29.3	COMPARATOR RESULT	120
29.4	OPAMP REGISTERS	120
30.	BLOCKS CONSUMPTION	121
31.	TYPICAL T AND V DEPENDENCIES	122
31.1	IDD CURRENTS	122
31.1.1	<i>General conditions</i>	122
31.2	RC OSCILLATOR 15MHZ AND 2MHZ	129
31.3	XTAL 32 KHZ AND RESONATOR 4MHZ	129
32.	ELECTRICAL SPECIFICATION	130
32.1	ABSOLUTE MAXIMUM RATINGS	130
32.2	HANDLING PROCEDURES	130
32.3	STANDARD OPERATING CONDITIONS	130
32.4	TYPICAL 32KHZ CRYSTAL SPECIFICATION	131
32.5	TYPICAL 4MHZ RESONATOR SPECIFICATION	131
32.6	DC CHARACTERISTICS - POWER SUPPLY CURRENTS	132
32.7	DC CHARACTERISTICS – VOLTAGE DETECTION LEVELS	133
32.8	DC CHARACTERISTICS – REFERENCE VOLTAGE	133
32.9	DC CHARACTERISTICS – OSCILLATORS	134
32.10	DC CHARACTERISTICS – OPAMP	135
32.11	DC CHARACTERISTICS – ADC	135
32.12	DC CHARACTERISTICS – TEMPERATURE SENSOR	136
32.13	DC CHARACTERISTICS - I/O PINS	136
33.	PACKAGE DRAWINGS	137
33.1	DIMENSIONS OF TSSOP28 PACKAGE	137
33.2	DIMENSIONS OF TSSOP20 PACKAGE	138
33.3	DIMENSIONS OF TSSOP16 PACKAGE	139
33.4	DIMENSIONS OF QFN20 PACKAGE	140
34.	PACKAGE MARKING	141
35.	ORDERING INFORMATION	142

Acronyms used in this document

MSB	most significant bit
LSB	least significant bit
CR / CPU/	CoolRisc 816 CPU core
NVM	Non Volatile Memory
ROM	Read Only Memory
RAM	Random Access Memory
API	Application Program Interface
GASP	General Access Serial Port
SW	Software
HW	Hardware
'1' / H / high	Determines HIGH value, logical true
'0' / L / low	Determines LOW value, logical false
POR	Power on reset
PWRC	Power check
SCWUP	Sleep Counter Wake-up
VLD	Voltage Level Detector
(T)	Tested in the production
(Q)	Validated during qualification
(D)	Guaranteed by the design

Nomenclature

Bit order scheme in this document is [n:0] where bit 'n' is the MSB and bit '0' is the LSB, unless otherwise stated. Positive logic is assumed, High ('1') values means asserted or active state and Low ('0') value means not asserted or inactive state, unless otherwise stated.

Register names and register bit names are written in **bold** typeface.

Signal names are written in ***italic-bold*** type face.

API subroutines are written in *italic*

Naming convention

The XTAL frequency is 32.768 kHz but in this document it is written 32 KHz (k=1000, K=1024).

Related Documents

- [1] CoolRISC 816L 8-bit Microprocessor Core, Hardware und Software Reference Manual V1.1 Mai 2002
- [2] ROM API document

1. EM6819 FAMILY (INCLUDING EM6819FX-B300)

EM6819 family ensures 0.9V battery operations and much more ...

Part number	Flash code (Words)	RAM (KB)	Supply range (V)	GPIO pins	Digital communication	Clock speed	Internal oscillator	8Bit Timers	PWM (up to channel)	Temp. Sensor	Additional analog	Additional digital	Self Write for software up	Package
EM6819F2-B006	2	4	0.9 - 3.6	-	04 to 12	SW-UART / DC	15MHz	RC 8kHz 2MHz 15MHz	4	4	-	PwrCk Brown-Out VLD	SCWUP	SO08
EM6819F2-B000	2	4	0.9 - 3.6	-	12 to 24	SW-UART / DC	15MHz	RC 8kHz 2MHz 15MHz Crystal 32kHz - 4MHz	4	4	8	OPAMP VLD	SCWUP	TSSOP16-20-28 QFN20
EM6819F2-A000	2	4	0.9 - 3.6	✓	12 to 20	SW-UART / DC	15MHz	RC 8kHz 2MHz 15MHz Crystal 32kHz - 4MHz	4	4	8	OPAMP VLD	SCWUP	TSSOP20-28 QFN20
EM6819F2-B300	2	4	2.0 - 5.0	-	16 to 24	SW-UART / DC	15MHz	RC 8kHz 2MHz 15MHz Crystal 32kHz - 4MHz	4	4	8	OPAMP VLD	SCWUP	TSSOP16-20-28 QFN20
EM6819F4-B005	4	8	0.9 - 3.6	-	04 to 12	SW-UART / DC	15MHz	RC 8kHz 2MHz 15MHz	4	4	4	OPAMP VLD	SCWUP	SO08
EM6819F4-A005	4	8	0.9 - 3.6	✓	08 to 12	SW-UART / DC	15MHz	RC 8kHz 2MHz 15MHz	4	4	4	OPAMP VLD	SCWUP	TSSOP16-20 QFN20
EM6819F4-A000	4	8	0.9 - 3.6	✓	12 to 24	SW-UART / DC	15MHz	RC 8kHz 2MHz 15MHz Crystal 32kHz - 4MHz	4	4	8	OPAMP VLD	SCWUP	TSSOP20-28 QFN20-32
EM6819F4-B000	4	8	0.9 - 3.6	-	12 to 24	SW-UART / DC	15MHz	RC 8kHz 2MHz 15MHz Crystal 32kHz - 4MHz	4	4	8	OPAMP VLD	SCWUP	TSSOP16-20-28 QFN20
EM6819F4-B100	4	8	1.8 - 3.6	-	12 to 24	SW-UART / DC	15MHz	RC 8kHz 2MHz 15MHz Crystal 32kHz - 4MHz	4	4	8	OPAMP VLD	SCWUP	TSSOP16-20-28 QFN20
EM6819F4-B300	4	8	2.0 - 5.0	-	16 to 24	SW-UART / DC	15MHz	RC 8kHz 2MHz 15MHz Crystal 32kHz - 4MHz	4	4	8	OPAMP VLD	SCWUP	TSSOP16-20-28 QFN20
EM6819F6-B004	6	12	0.9 - 3.6	-	04 to 24	SW-UART / DC	15MHz	RC 8kHz 2MHz 15MHz	4	4	8	OPAMP VLD	SCWUP	SO08
EM6819F6-A000	6	12	0.9 - 3.6	✓	12 to 24	SW-UART / DC	15MHz	RC 8kHz 2MHz 15MHz Crystal 32kHz - 4MHz	4	4	8	OPAMP VLD	SCWUP	TSSOP20-28 QFN20-32
EM6819F6-B100	6	12	1.8 - 3.6	-	12 to 24	SW-UART / DC	15MHz	RC 8kHz 2MHz 15MHz Crystal 32kHz - 4MHz	4	4	8	OPAMP VLD	SCWUP	TSSOP16-20-28 QFN20
EM6819F6-A100	6	12	1.8 - 3.6	✓	12 to 24	SW-UART / DC	15MHz	RC 8kHz 2MHz 15MHz Crystal 32kHz - 4MHz	4	4	8	OPAMP VLD	SCWUP	TSSOP20-28 QFN20-32
EM6819F6-B300	6	12	2.0 - 5.0	-	16 to 24	SW-UART / DC	15MHz	RC 8kHz 2MHz 15MHz Crystal 32kHz - 4MHz	4	4	8	OPAMP VLD	SCWUP	TSSOP16-20-28 QFN20

Note 1: Ask for package & volume availability

- Non Volatile Memory**
- RAM**
- Random Access Memory**
- General Purpose Input Output**
- GPIO**
- Serial Peripheral Interface**
- SPI**
- RC**
- Fully embedded RC Oscillator**
- Oscillator on chip**
- Crystal**
- WD**
- PWM**
- Pulse Width Modulation**
- ADC**
- Analog to Digital Converter**
- OPAMP**
- Operational Amplifier**
- PwrCk**
- Power Check on start-up**
- VLD**
- Voltage Level Detector**
- ISP**
- In-System Programming**
- SCWUP**
- Sleep Counter Wake-Up**

2. SYSTEM OVERVIEW

The circuit's function blocks can be splitted in 5 different categories:

- Power management and security functions
- Memories and CPU Core
- Clock selection, clock switching and system peripherals
- Digital and Analog internal peripherals
- Communication interfaces via the IO pads

Figure 1, EM6819F6-B300 overview

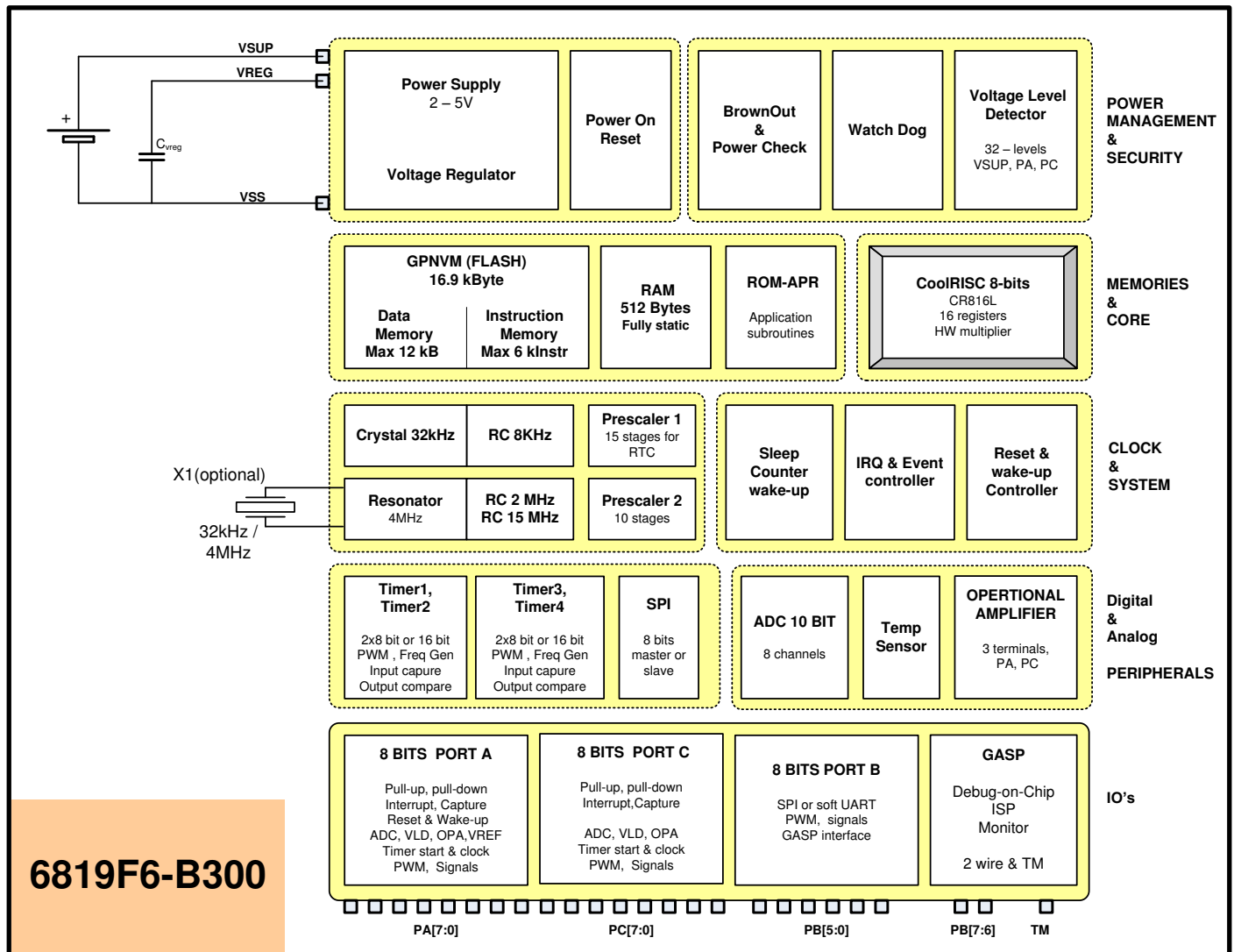

Power management and security functions

The power management block assures a proper system start at power up with Power on reset and power check function. The internal Brownout supervises the CPU and core internal power supply and asserts a reset at undervoltage. The watchdog function monitors the CPU execution, whereas the VLD can be used to monitor internal or external voltages. Its results are available to the user to take actions accordingly.

Memories and CPU Core

This part contains all user program memory (FLASH), the non volatile data memory (mapped into the FLASH memory), the RAM and the vendor supplied application subroutines (ROM-API) for non volatile memory modifications. An essential part of this block is also the CR816 microprocessor core.

Clock selection, clock switching and system peripherals

This block takes care of all internal and external clock sources. It synchronizes the clocks where needed and assures that the system can not hang-up due to faulty clock switching (i.e avoids switching to a non-present clock source). This block is also an essential part of the low power architecture by minimizing the total energy consumption by keeping the active clocking nodes to a strict minimum.

Digital and Analog internal peripherals

This part contains all the user peripherals such as timer, SPI, ADC, etc ... These peripherals are user configurable and fully adjustable to the user application.

Communication interfaces via the IO pads

Here are all the external communication channels grouped. All communication goes through at least 1 of the max 24 IO's. Several internal functions such as, serial interface, PWM, freq outputs, etc. are mapped to the IO's.

2.1 OPERATING MODES

The circuit has 4 distinctive operations modes whereas Standby and Sleep are specific low power modes

- Active CPU running all functions may be used
- StandBy CPU in Standby not clocked. Peripheral functions may be running
- Sleep CPU in Standby not clocked. Peripherals stopped except for specifically enabled functions

2.1.1 ACTIVE MODE

The active mode is the default mode after any system reset. In this mode all peripherals are powered and ready to be used. All Low power modes are initiated from the active mode by executing the HALT instruction.

If using an external high frequency clock input and the derived CPU clock is higher 6MHz the user shall set the bit **FrcFastRead** which acts as a booster for the Flash reading. For all internal clock selection the boosting is done automatically.

2.2 LOW POWER MODES

The Low power modes are enabled by the CPU HALT instruction execution. The resulting Low power mode selection then depends on the **SelSleep** bit setting, which is located in the system register **RegSysCfg1**.

Mode	HALT Instruction	RegSysCfg1.SelSleep
Active	No	X
StandBy	Yes	0
Sleep	Yes	1

2.2.1 STANDBY MODE

This mode is activated by HALT instruction if **SelSleep**='0'.

The active clock oscillator for the CPU clock source as selected by **SelCkCR** will be disabled in StandBy mode if it is not used by other block/peripheral or it's not forced-on. The Flash memory is disabled to save power.

If fast wake-up is needed the user can choose to leave the Flash memory enabled in StandBy mode by setting the bit **StdByFastWkUp** in register **RegSysCfg1** to '1'.

Resume from standby mode and going back to active mode with an Event, an Interrupt or a system reset.

Wake-up time from Standby mode is 1.5us if **StdByFastWkUp** ='1' and CPU is on 15 MHz with the 15 MHz RC oscillator forced on.

Wake-up time from Standby mode is 10us if **StdByFastWkUp** ='1' and CPU is on 2 MHz with the 2 MHz RC oscillator forced on.

Wake-up time from Standby mode is 150us if **StdByFastWkUp** ='0' and CPU is on 2 MHz with the 2 MHz RC oscillator forced on.

Wake-up delay is measured from the time of the wake-up interrupt until the result of the first CPU instruction.

The bit **StdByFastWkUp** ='1' will increase the standby power consumption by ~1.5uA at any CPU freq settings except if the CPU is set to RC_15MHz, RC_15MHz/2 or the bit **FrcFastRead** is set. In these cases the extra power

consumption will be ~35uA. To avoid this extra 35uA of current the user must predivide the CPU clock just before going to standby mode to values below 6MHz by

- a) use RC_15MHz/4 or lower frequencies based on 2MHz, 32kHz, RC8k,
- b) or in case of external high freq clock input, set the CK_CPU predivider such that the resulting CPU frequency is below 6MHz

After wake-up the original high frequency CPU clock can immediately be reinstalled with little wake-up time penalty.

Using **StdByFastWkUp** = '1' together with **FrcFastRead** = '1' will draw additional 35uA independent of the selected CPU clock source. It should therefore be avoided by clearing FrcFastRead before going into standby mode.

2.2.2 SLEEP MODE

This mode is activated by HALT instruction if **SelSleep** = '1'.

In Sleep mode the Temperature sensor and the ADC are disabled. All oscillators are forced off except the RC 8kHz oscillator if used for sleep counter wake-up function.

All register data are maintained during sleep. The Flash memory is switched off for power save.

Resume from Sleep mode back to active mode with selected Interrupts and Events or by a system reset or by the sleep counter wakeup function SCWUP.

2.2.3 SLEEP WAKE-UP

Normal Wake-up from Sleep mode will take typically 250us until the 1st instruction after wake-up is executed.

By setting the bit **StdByFastWkUp** prior to entering sleep mode the wake-up from sleep mode is greatly reduced.

- In case of 2MHz RC Oscillator as CPU clock the wake-up time in fast mode is typically 18us
- In case of 15MHz RC Oscillator as CPU clock the wake-up time in fast mode is typically 11us

This wakeup time is measured from the wake-up event until the 3rd instruction after the wakeup event is changing a port output pin status.

The bit **StdByFastWkUp** = '1' will increase the sleep power consumption by ~1.5uA at any CPU freq settings except if the CPU is set to RC_15MHz, RC_15MHz/2 or the bit **FrcFastRead** is set. In these cases the extra power consumption will be ~35uA. To avoid this extra 35uA of current the user must predivide the CPU clock just before going to sleep mode to values below 6MHz by

- c) use RC_15MHz/4 or lower frequencies based on 2MHz, 32kHz, RC8k,
- d) or in case of external high freq clock input, set the CK_CPU predivider such that the resulting CPU frequency is below 6MHz

After sleep wake-up the original high frequency CPU clock can immediately be reinstalled with almost no wake-up time penalty.

Using **StdByFastWkUp** = '1' together with **FrcFastRead** = '1' will draw additional 35uA independent of the selected CPU clock source. It should therefore be avoided by clearing FrcFastRead before going into sleep mode.

Note:

Interrupt sources for wake-up from the Sleep mode are defined in 12.2 Interrupt acquisition

Note:

Event sources for wake-up from the Sleep mode are defined in 12.8 Event acquisition

2.2.4 OPERATION MODE REGISTERS

0x0000		RegSysCfg1			System Configuration - 1
Bits	Name	Type	ResVal	ResSrc	Description
7	SelSleep	RW	0	ResSys	Select Sleep mode on Halt
6:5	-	NI	0	ResSys	
4	EnBrownOut	RW	1	ResAna	Enable Brown Out
3:2	XtalCldStart	RW	'00'	ResSys	Select Xtal Osc. ColdStart length
1	StdByFastWkUp	RW	0	ResSys	Stand-by mode fast Wake-up
0	-	NI	0		

0x0006		RegResFlg			Reset Flags
Bits	Name	Type	ResVal	ResSrc	Description
7	ResFlgPA	ResFlg	0	POR	Flag Reset from Port-A
6	ResFlgWD	ResFlg	0	POR	Flag Reset from WatchDog
5	ResFlgBO	ResFlg	0	POR	Flag Reset from Brown-Out
4	ResFlgGasp	ResFlg	0	POR	Flag Reset from GASP
3	ResFlgBE	ResFlg	0	POR	Flag Reset from CoolRisc Bus-Error
2:0		NI	0		

2.3 REGISTER TYPES

The peripheral registers are of different types. The specific type of the register is marked in its table definition. Used types are: RW, RO, OS, INT, INT-SET, STS, NI, RESFLG

Read-Write Register (RW)

- the software is able to write high and low values
- the software is able to read out the last written value
- the initial and reset value is according to its specified reset value

Read Only register (RO)

- the software is able to read out the current status of the hardware status
- the initial and reset value is according to the value of the initial hardware status or hardware status after reset

One Shot register (OS)

- the software writing of the specified value is producing the given action
- the software always reads a low value

Interrupt status register (INT)

- Software writing '0' will clear a pending interrupt, clear has priority over a new arriving interrupt.
- Software writing '1' will set the interrupt status bit (software interrupt). This has highest priority.
- If the software reads the interrupt status at '1' it will clear it after the reading.
- If the software reads '0', no action is performed.
- An incoming hardware interrupt event will set the status bit, this action has priority over clear by software read.
- The reset value is '0'

Status register (STS)

- the software can write only the allowed values into the register. These values are specified case-by-case.
- the hardware may also be able to change the register value according to its function
- the access priority software over hardware is specified case-by-case.
- the readout value corresponds to the last change (software or hardware change)
- the initial and reset value are specified case-by-case

Not Implemented register (NI)

- no action on write
- the software is reading the specified constant value (normally '0')

Reset flag register (RESFLG)

- an incoming hardware event sets or clears the register according on its specification
- the readout value is according to the last hardware event and specified case-by-case.
- The initial and reset value is according to the value specified case-by-case defined by its last hardware event
- The software is able to clear the flag by writing '1' to it, writing '0' has no effect
- Hardware event has priority over software access.

2.4 POWER MANAGEMENT

The internal voltage regulator and the voltage multiplier assure a constant voltage VREG to the memory cells, GPNVM, RAM, ROM, the logic, the CPU core and sensible analog cells over the whole voltage range.

Figure 2, Power Management architecture

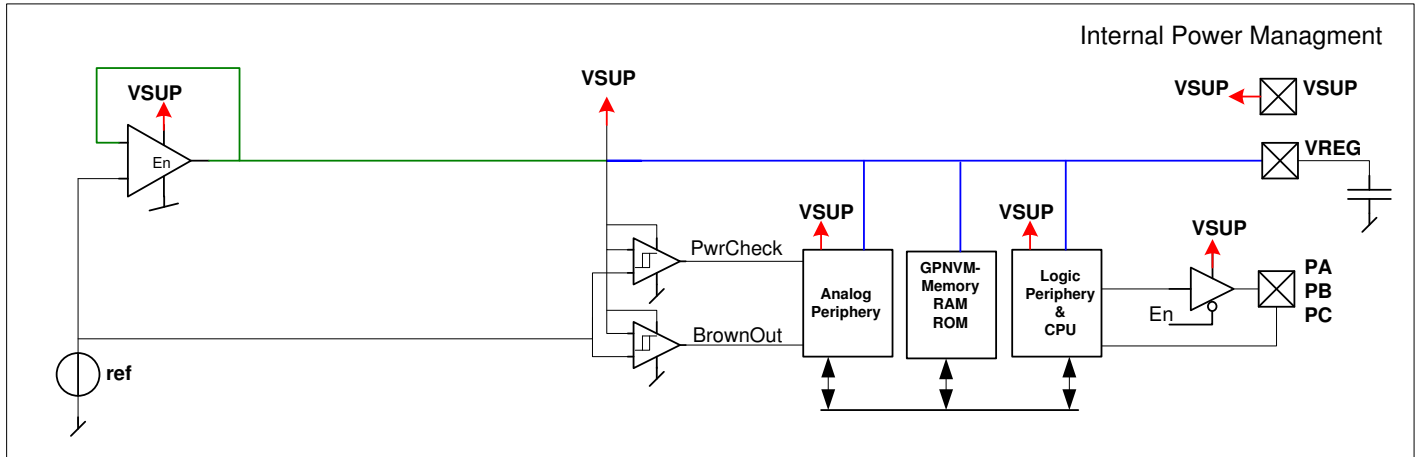

2.4.1 BROWNOUT

If enabled, the BrownOut supervises the VREG voltage. As soon as Vreg drop below the minimal safe operation voltage for core operations and as such underpasses the brownout limits, reset **ResBO** is asserted. The circuit goes in reset state and can only recover from reset if the voltage rises above the PwrCheck level. ($V_{PWRCheck} > V_{Brownout}$).

The brownout can be disabled by **EnBrownOut** bit. The function is also automatically stopped in sleep mode if none of the Bandgap reference, ADC or OPAMP is active.

2.4.2 POWERCHECK

Powercheck is enabled on system power-up, it keeps the circuit in idle state until VREG voltage is sufficient high for safe core operation.

($V_{REG} > V_{PWRCheck} > V_{Brownout}$)

Powercheck is active after

- initial power-up,
- wake-up from sleep
- after any system reset

2.4.3 POR

POR circuitry supervises the supply voltage VSUP at start-up and during all operation modes. As long as VSUP is below the V_{POR} voltage the circuit is in reset state. If the VSUP falls below V_{POR} the circuit will enter reset state even if brownout was disabled.

At power-up the POR initializes the whole circuit except the RAM and powercheck is initiated.



2.4.4 POWERMANAGMENT REGISTERS

0x0000		RegSysCfg1			System Configuration - 1
Bits	Name	Type	ResVal	ResSrc	Description
7	SelSleep	RW	0	ResSys	Select Sleep mode on Halt
6:5		NI	0		
4	EnBrownOut	RW	1	ResAna	Enable Brown Out
3:2	XtalCldStart	RW	'00'	ResSys	Select Xtal Osc. ColdStart length
1	StdByFastWkUp	RW	0	ResSys	Stand-by mode fast Wake-up
0		NI	0		



EM6819FX-B300

2.5 REGISTER MAP

RegName	Address	Init.	Bit7	Bit6	Bit5	Bit4	Bit3	Bit2	Bit1	Bit0
RegSysCfg1	0x0000	0x10	SelSleep	-	-	EnBrownOut	XtalCldStart(1)	XtalCldStart(0)	StdByFastWkUp	-
RegEnResPA	0x0001	0x00	EnResPA(7)	EnResPA(6)	EnResPA(5)	EnResPA(4)	EnResPA(3)	EnResPA(2)	EnResPA(1)	EnResPA(0)
RegClockCfg1	0x0003	0x18	SelCkExt(1)	SelCkExt(0)	SelCkHi(1)	SelCkHi(0)	SelCkLo(1)	SelCkLo(0)	-	FrcFastRead
RegClockCfg2	0x0004	0x03	FrcEnRC15M	FrcEnRC2M	FrcEnRC8k	FrcEnExt	SelCkCR(3)	SelCkCR(2)	SelCkCR(1)	SelCkCR(0)
RegClockCfg3	0x0005	0x70	SelCkPr1(2)	SelCkPr1(1)	SelCkPr1(0)	SelCkPr2(2)	SelCkPr2(1)	SelCkPr2(0)	-	-
RegResFlg	0x0006	0x00	ResFlgPA	ResFlgWD	ResFlgBO	ResFlgGasp	ResFlgBE	-	-	-
RegPrescCfg	0x0007	0x00	Presc1Clr	Presc1Len	Presc1SelIntB	Presc2Clr	-	-	-	-
RegPresc1Val	0x0008	0xFF	Presc1Val(7)	Presc1Val(6)	Presc1Val(5)	Presc1Val(4)	Presc1Val(3)	Presc1Val(2)	Presc1Val(1)	Presc1Val(0)
RegPresc2Val	0x0009	0xFF	Presc2Val(7)	Presc2Val(6)	Presc2Val(5)	Presc2Val(4)	Presc2Val(3)	Presc2Val(2)	Presc2Val(1)	Presc2Val(0)
RegPADIn	0x000A	0x00	PADIn(7)	PADIn(6)	PADIn(5)	PADIn(4)	PADIn(3)	PADIn(2)	PADIn(1)	PADIn(0)
RegPADOOut	0x000B	0x00	PADOOut(7)	PADOOut(6)	PADOOut(5)	PADOOut(4)	PADOOut(3)	PADOOut(2)	PADOOut(1)	PADOOut(0)
RegPAInpE	0x000C	0x00	PAInpE(7)	PAInpE(6)	PAInpE(5)	PAInpE(4)	PAInpE(3)	PAInpE(2)	PAInpE(1)	PAInpE(0)
RegPAOE	0x000D	0x00	PAOE(7)	PAOE(6)	PAOE(5)	PAOE(4)	PAOE(3)	PAOE(2)	PAOE(1)	PAOE(0)
RegPAPU	0x000E	0x00	PAPU(7)	PAPU(6)	PAPU(5)	PAPU(4)	PAPU(3)	PAPU(2)	PAPU(1)	PAPU(0)
RegPAPD	0x000F	0x00	PAPD(7)	PAPD(6)	PAPD(5)	PAPD(4)	PAPD(3)	PAPD(2)	PAPD(1)	PAPD(0)
RegPAOD	0x0010	0x00	PAOD(7)	PAOD(6)	PAOD(5)	PAOD(4)	PAOD(3)	PAOD(2)	PAOD(1)	PAOD(0)
RegPAOutCfg0	0x0011	0x00	PA3OutSel(1)	PA3OutSel(0)	PA2OutSel(1)	PA2OutSel(0)	PA1OutSel(1)	PA1OutSel(0)	PA0OutSel(1)	PA0OutSel(0)
RegPAOutCfg1	0x0012	0x00	PA7OutSel(1)	PA7OutSel(0)	PA6OutSel(1)	PA6OutSel(0)	PA5OutSel(1)	PA5OutSel(0)	PA4OutSel(1)	PA4OutSel(0)
RegPADebCfg1	0x0013	0x00	PA3DebSel(1)	PA3DebSel(0)	PA2DebSel(1)	PA2DebSel(0)	PA1DebSel(1)	PA1DebSel(0)	PA0DebSel(1)	PA0DebSel(0)
RegPADebCfg2	0x0014	0x00	PA7DebSel(1)	PA7DebSel(0)	PA6DebSel(1)	PA6DebSel(0)	PA5DebSel(1)	PA5DebSel(0)	PA4DebSel(1)	PA4DebSel(0)
RegPAIntEdg	0x0015	0xFF	PAIntEdg(7)	PAIntEdg(6)	PAIntEdg(5)	PAIntEdg(4)	PAIntEdg(3)	PAIntEdg(2)	PAIntEdg(1)	PAIntEdg(0)
RegPBDIn	0x0016	0x00	PBDIn(7)	PBDIn(6)	PBDIn(5)	PBDIn(4)	PBDIn(3)	PBDIn(2)	PBDIn(1)	PBDIn(0)
RegPBDOOut	0x0017	0x00	PBDOOut(7)	PBDOOut(6)	PBDOOut(5)	PBDOOut(4)	PBDOOut(3)	PBDOOut(2)	PBDOOut(1)	PBDOOut(0)
RegPBInpE	0x0018	0x00	PBInpE(7)	PBInpE(6)	PBInpE(5)	PBInpE(4)	PBInpE(3)	PBInpE(2)	PBInpE(1)	PBInpE(0)
RegPBOE	0x0019	0x00	PBOE(7)	PBOE(6)	PBOE(5)	PBOE(4)	PBOE(3)	PBOE(2)	PBOE(1)	PBOE(0)
RegPBPU	0x001A	0x00	PBPU(7)	PBPU(6)	PBPU(5)	PBPU(4)	PBPU(3)	PBPU(2)	PBPU(1)	PBPU(0)
RegPBPD	0x001B	0x00	PBPD(7)	PBPD(6)	PBPD(5)	PBPD(4)	PBPD(3)	PBPD(2)	PBPD(1)	PBPD(0)
RegPBOD	0x001C	0x00	PBOD(7)	PBOD(6)	PBOD(5)	PBOD(4)	PBOD(3)	PBOD(2)	PBOD(1)	PBOD(0)



EM6819FX-B300

RegName	Address	Init.	Bit7	Bit6	Bit5	Bit4	Bit3	Bit2	Bit1	Bit0
RegPBOOutCfg0	0x001D	0x00	PB3OutSel(1)	PB3OutSel(0)	PB2OutSel(1)	PB2OutSel(0)	PB1OutSel(1)	PB1OutSel(0)	PB0OutSel(1)	PB0OutSel(0)
RegPBOOutCfg1	0x001E	0x00	PB7OutSel(1)	PB7OutSel(0)	PB6OutSel(1)	PB6OutSel(0)	PB5OutSel(1)	PB5OutSel(0)	PB4OutSel(1)	PB4OutSel(0)
RegPCDIn	0x001F	0x00	PCDIn(7)	PCDIn(6)	PCDIn(5)	PCDIn(4)	PCDIn(3)	PCDIn(2)	PCDIn(1)	PCDIn(0)
RegPCDOut	0x0020	0x00	PCDOut(7)	PCDOut(6)	PCDOut(5)	PCDOut(4)	PCDOut(3)	PCDOut(2)	PCDOut(1)	PCDOut(0)
RegPCInpE	0x0021	0x00	PCInpE(7)	PCInpE(6)	PCInpE(5)	PCInpE(4)	PCInpE(3)	PCInpE(2)	PCInpE(1)	PCInpE(0)
RegPCOE	0x0022	0x00	PCOE(7)	PCOE(6)	PCOE(5)	PCOE(4)	PCOE(3)	PCOE(2)	PCOE(1)	PCOE(0)
RegPCPU	0x0023	0x00	PCPU(7)	PCPU(6)	PCPU(5)	PCPU(4)	PCPU(3)	PCPU(2)	PCPU(1)	PCPU(0)
RegPCPD	0x0024	0x00	PCPD(7)	PCPD(6)	PCPD(5)	PCPD(4)	PCPD(3)	PCPD(2)	PCPD(1)	PCPD(0)
RegPCOD	0x0025	0x00	PCOD(7)	PCOD(6)	PCOD(5)	PCOD(4)	PCOD(3)	PCOD(2)	PCOD(1)	PCOD(0)
RegPCOutCfg0	0x0026	0x00	PC3OutSel(1)	PC3OutSel(0)	PC2OutSel(1)	PC2OutSel(0)	PC1OutSel(1)	PC1OutSel(0)	PC0OutSel(1)	PC0OutSel(0)
RegPCOutCfg1	0x0027	0x00	PC7OutSel(1)	PC7OutSel(0)	PC6OutSel(1)	PC6OutSel(0)	PC5OutSel(1)	PC5OutSel(0)	PC4OutSel(1)	PC4OutSel(0)
RegPCDebCfg1	0x0028	0x00	PC3DebSel(1)	PC3DebSel(0)	PC2DebSel(1)	PC2DebSel(0)	PC1DebSel(1)	PC1DebSel(0)	PC0DebSel(1)	PC0DebSel(0)
RegPCDebCfg2	0x0029	0x00	PC7DebSel(1)	PC7DebSel(0)	PC6DebSel(1)	PC6DebSel(0)	PC5DebSel(1)	PC5DebSel(0)	PC4DebSel(1)	PC4DebSel(0)
RegPCIntEdg	0x002A	0xFF	PCIntEdg(7)	PCIntEdg(6)	PCIntEdg(5)	PCIntEdg(4)	PCIntEdg(3)	PCIntEdg(2)	PCIntEdg(1)	PCIntEdg(0)
RegGaspDIn	0x002B	0x00	GaspDIn(7)	GaspDIn(6)	GaspDIn(5)	GaspDIn(4)	GaspDIn(3)	GaspDIn(2)	GaspDIn(1)	GaspDIn(0)
RegGaspDOut	0x002C	0x00	GaspDOut(7)	GaspDOut(6)	GaspDOut(5)	GaspDOut(4)	GaspDOut(3)	GaspDOut(2)	GaspDOut(1)	GaspDOut(0)
RegGaspMode	0x002D	0x00	GaspTM	GaspMode	GaspSU	GaspISP	GaspDoC	GaspTest	-	-
RegDoCPM1L	0x002E	0x00	DoCPM1L(7)	DoCPM1L(6)	DoCPM1L(5)	DoCPM1L(4)	DoCPM1L(3)	DoCPM1L(2)	DoCPM1L(1)	DoCPM1L(0)
RegDoCPM1M	0x002F	0x00	-	-	-	DoCPM1M(4)	DoCPM1M(3)	DoCPM1M(2)	DoCPM1M(1)	DoCPM1M(0)
RegDoCPM2L	0x0030	0x00	DoCPM2L(7)	DoCPM2L(6)	DoCPM2L(5)	DoCPM2L(4)	DoCPM2L(3)	DoCPM2L(2)	DoCPM2L(1)	DoCPM2L(0)
RegDoCPM2M	0x0031	0x00	-	-	-	DoCPM2M(4)	DoCPM2M(3)	DoCPM2M(2)	DoCPM2M(1)	DoCPM2M(0)
RegDoCPM3L	0x0032	0x00	DoCPM3L(7)	DoCPM3L(6)	DoCPM3L(5)	DoCPM3L(4)	DoCPM3L(3)	DoCPM3L(2)	DoCPM3L(1)	DoCPM3L(0)
RegDoCPM3M	0x0033	0x00	-	-	-	DoCPM3M(4)	DoCPM3M(3)	DoCPM3M(2)	DoCPM3M(1)	DoCPM3M(0)
RegDoCDM1L	0x0034	0x00	DoCDM1L(7)	DoCDM1L(6)	DoCDM1L(5)	DoCDM1L(4)	DoCDM1L(3)	DoCDM1L(2)	DoCDM1L(1)	DoCDM1L(0)
RegDoCDM1M	0x0035	0x00	DoCDM1M(7)	DoCDM1M(6)	DoCDM1M(5)	DoCDM1M(4)	DoCDM1M(3)	DoCDM1M(2)	DoCDM1M(1)	DoCDM1M(0)
RegDoCEn	0x0036	0x00	DoCEnPM1	DoCEnPM2	DoCEnPM3	DoCEnDM1(1)	DoCEnDM1(0)	-	-	-
RegDoCStat	0x0037	0x00	DoCPM1Stat	DoCPM2Stat	DoCPM3Stat	DoCDM1Stat	-	-	-	-
RegCRC16DIn	0x0038	0x00	CRC16DIn(7)	CRC16DIn(6)	CRC16DIn(5)	CRC16DIn(4)	CRC16DIn(3)	CRC16DIn(2)	CRC16DIn(1)	CRC16DIn(0)
RegCRC16L	0x0039	0x00	CRC16L(7)	CRC16L(6)	CRC16L(5)	CRC16L(4)	CRC16L(3)	CRC16L(2)	CRC16L(1)	CRC16L(0)



EM6819FX-B300

RegName	Address	Init.	Bit7	Bit6	Bit5	Bit4	Bit3	Bit2	Bit1	Bit0
RegCRC16M	0x003A	0x00	CRC16M(7)	CRC16M(6)	CRC16M(5)	CRC16M(4)	CRC16M(3)	CRC16M(2)	CRC16M(1)	CRC16M(0)
RegTimersCfg	0x003B	0x00	Tim12Chain	Tim34Chain	Tim1AR	Tim2AR	Tim3AR	Tim4AR	Tim1SWCpt	Tim3SWCpt
RegTimersStart	0x003C	0x00	Tim1SWStart	Tim1Pulse	Tim2SWStart	Tim2Pulse	Tim3SWStart	Tim3Pulse	Tim4SWStart	Tim4Pulse
RegTim1Cfg	0x003D	0x00	Tim1EnPWM	Tim1IntSel	Tim1SelStart(2)	Tim1SelStart(1)	Tim1SelStart(0)	Tim1SelClk(2)	Tim1SelClk(1)	Tim1SelClk(0)
RegTim1CptCmpCfg	0x003E	0x00	Tim1CptEdg(1)	Tim1CptEdg(0)	Tim1CptEvtSrc(1)	Tim1CptEvtSrc(0)	Tim1CmpFullAct(1)	Tim1CmpFullAct(0)	Tim1CmpValAct(1)	Tim1CmpValAct(0)
RegTim1Status	0x003F	0x00	Tim1Status(7)	Tim1Status(6)	Tim1Status(5)	Tim1Status(4)	Tim1Status(3)	Tim1Status(2)	Tim1Status(1)	Tim1Status(0)
RegTim1Full	0x0040	0xFF	Tim1Full(7)	Tim1Full(6)	Tim1Full(5)	Tim1Full(4)	Tim1Full(3)	Tim1Full(2)	Tim1Full(1)	Tim1Full(0)
RegTim1CmpVal	0x0041	0x00	Tim1CmpVal(7)	Tim1CmpVal(6)	Tim1CmpVal(5)	Tim1CmpVal(4)	Tim1CmpVal(3)	Tim1CmpVal(2)	Tim1CmpVal(1)	Tim1CmpVal(0)
RegTim1CptVal	0x0042	0x00	Tim1CptVal(7)	Tim1CptVal(6)	Tim1CptVal(5)	Tim1CptVal(4)	Tim1CptVal(3)	Tim1CptVal(2)	Tim1CptVal(1)	Tim1CptVal(0)
RegTim2Cfg	0x0043	0x00	Tim2EnPWM	Tim2IntSel	Tim2SelStart(2)	Tim2SelStart(1)	Tim2SelStart(0)	Tim2SelClk(2)	Tim2SelClk(1)	Tim2SelClk(0)
RegTim2CptCmpCfg	0x0044	0x00	Tim2CptEdg(1)	Tim2CptEdg(0)	Tim2CptEvtSrc(1)	Tim2CptEvtSrc(0)	Tim2CmpFullAct(1)	Tim2CmpFullAct(0)	Tim2CmpValAct(1)	Tim2CmpValAct(0)
RegTim2Status	0x0045	0x00	Tim2Status(7)	Tim2Status(6)	Tim2Status(5)	Tim2Status(4)	Tim2Status(3)	Tim2Status(2)	Tim2Status(1)	Tim2Status(0)
RegTim2Full	0x0046	0xFF	Tim2Full(7)	Tim2Full(6)	Tim2Full(5)	Tim2Full(4)	Tim2Full(3)	Tim2Full(2)	Tim2Full(1)	Tim2Full(0)
RegTim2CmpVal	0x0047	0x00	Tim2CmpVal(7)	Tim2CmpVal(6)	Tim2CmpVal(5)	Tim2CmpVal(4)	Tim2CmpVal(3)	Tim2CmpVal(2)	Tim2CmpVal(1)	Tim2CmpVal(0)
RegTim2CptVal	0x0048	0x00	Tim2CptVal(7)	Tim2CptVal(6)	Tim2CptVal(5)	Tim2CptVal(4)	Tim2CptVal(3)	Tim2CptVal(2)	Tim2CptVal(1)	Tim2CptVal(0)
RegTim3Cfg	0x0049	0x00	Tim3EnPWM	Tim3IntSel	Tim3SelStart(2)	Tim3SelStart(1)	Tim3SelStart(0)	Tim3SelClk(2)	Tim3SelClk(1)	Tim3SelClk(0)
RegTim3CptCmpCfg	0x004A	0x00	Tim3CptEdg(1)	Tim3CptEdg(0)	Tim3CptEvtSrc(1)	Tim3CptEvtSrc(0)	Tim3CmpFullAct(1)	Tim3CmpFullAct(0)	Tim3CmpValAct(1)	Tim3CmpValAct(0)
RegTim3Status	0x004B	0x00	Tim3Status(7)	Tim3Status(6)	Tim3Status(5)	Tim3Status(4)	Tim3Status(3)	Tim3Status(2)	Tim3Status(1)	Tim3Status(0)
RegTim3Full	0x004C	0xFF	Tim3Full(7)	Tim3Full(6)	Tim3Full(5)	Tim3Full(4)	Tim3Full(3)	Tim3Full(2)	Tim3Full(1)	Tim3Full(0)
RegTim3CmpVal	0x004D	0x00	Tim3CmpVal(7)	Tim3CmpVal(6)	Tim3CmpVal(5)	Tim3CmpVal(4)	Tim3CmpVal(3)	Tim3CmpVal(2)	Tim3CmpVal(1)	Tim3CmpVal(0)
RegTim3CptVal	0x004E	0x00	Tim3CptVal(7)	Tim3CptVal(6)	Tim3CptVal(5)	Tim3CptVal(4)	Tim3CptVal(3)	Tim3CptVal(2)	Tim3CptVal(1)	Tim3CptVal(0)
RegTim4Cfg	0x004F	0x00	Tim4EnPWM	Tim4IntSel	Tim4SelStart(2)	Tim4SelStart(1)	Tim4SelStart(0)	Tim4SelClk(2)	Tim4SelClk(1)	Tim4SelClk(0)
RegTim4CptCmpCfg	0x0050	0x00	Tim4CptEdg(1)	Tim4CptEdg(0)	Tim4CptEvtSrc(1)	Tim4CptEvtSrc(0)	Tim4CmpFullAct(1)	Tim4CmpFullAct(0)	Tim4CmpValAct(1)	Tim4CmpValAct(0)
RegTim4Status	0x0051	0x00	Tim4Status(7)	Tim4Status(6)	Tim4Status(5)	Tim4Status(4)	Tim4Status(3)	Tim4Status(2)	Tim4Status(1)	Tim4Status(0)
RegTim4Full	0x0052	0xFF	Tim4Full(7)	Tim4Full(6)	Tim4Full(5)	Tim4Full(4)	Tim4Full(3)	Tim4Full(2)	Tim4Full(1)	Tim4Full(0)
RegTim4CmpVal	0x0053	0x00	Tim4CmpVal(7)	Tim4CmpVal(6)	Tim4CmpVal(5)	Tim4CmpVal(4)	Tim4CmpVal(3)	Tim4CmpVal(2)	Tim4CmpVal(1)	Tim4CmpVal(0)
RegTim4CptVal	0x0054	0x00	Tim4CptVal(7)	Tim4CptVal(6)	Tim4CptVal(5)	Tim4CptVal(4)	Tim4CptVal(3)	Tim4CptVal(2)	Tim4CptVal(1)	Tim4CptVal(0)
RegADCCfg1	0x0055	0x00	EnADC	RunContMeas	RunSinglMeas	EnTempSens	ADCSmplRate(2)	ADCSmplRate(1)	ADCSmplRate(0)	ADC8bit
RegADCCfg2	0x0056	0x00	ADCSelRef(1)	ADCSelRef(0)	ADCSelRange(1)	ADCSelRange(0)	ADCLowNoise	-	-	-
RegADCOut0	0x0057	0x00	ADCOut0(7)	ADCOut0(6)	ADCOut0(5)	ADCOut0(4)	ADCOut0(3)	ADCOut0(2)	ADCOut0(1)	ADCOut0(0)



EM6819FX-B300

RegName	Address	Init.	Bit7	Bit6	Bit5	Bit4	Bit3	Bit2	Bit1	Bit0
RegADCOut1	0x0058	0x00	ADCBusy	ADCSELsrc(2)	ADCSELsrc(1)	ADCSELsrc(0)	StsTempSens	ADCOuTlSB	ADCOuT1(1)	ADCOuT1(0)
RegADCOFFsetL	0x0059	0x00	ADCOFFsetL(7)	ADCOFFsetL(6)	ADCOFFsetL(5)	ADCOFFsetL(4)	ADCOFFsetL(3)	ADCOFFsetL(2)	ADCOFFsetL(1)	ADCOFFsetL(0)
RegADCOFFsetM	0x005A	0x04	-	-	-	-	-	ADCOFFsetM(2)	ADCOFFsetM(1)	ADCOFFsetM(0)
RegOpAmpCfG1	0x005B	0x00	EnOpAmp	EnComp	-	CompRes	SelComplnt(1)	SelComplnt(0)	-	-
RegOpAmpCfG2	0x005C	0x00	OpAmpSelInpPos(1)	OpAmpSelInpPos(0)	OpAmpSelInpNeg(1)	OpAmpSelInpNeg(0)	OpAmpSelOut	-	-	-
-	0x005D	0x--	-	-	-	-	-	-	-	-
RegSVLDCfG1	0x005E	0x00	EnSVLD	SVLDRes	SVLDSELsrc(2)	SVLDSELsrc(1)	SVLDSELsrc(0)	-	-	-
RegSVLDCfG2	0x005F	0x00	-	-	-	SVLDSELlVl(4)	SVLDSELlVl(3)	SVLDSELlVl(2)	SVLDSELlVl(1)	SVLDSELlVl(0)
RegBgrCfG	0x0060	0x00	BgrEnOut	NVMEWrite	-	-	-	-	-	-
RegInt0Sts	0x0061	0x00	Int0StsPort(0)	Int0StsTim1	Int0StsPsc11Hz	Int0StsADC	Int0StsDoCDM	Int0StsDoCPM	Int0StsGasp	Int0StsPMMiss
RegInt1Sts	0x0062	0x00	Int1StsPort(2)	Int1StsPort(1)	Int1StsTim2	Int1StsTim3	Int1StsOpAmp	Int1StsPsc1B	Int1StsSPIStop	Int1StsSPIStart
RegInt2Sts	0x0063	0x00	Int2StsSVLD	Int2StsSlpCnt	Int2StsPort(7)	Int2StsPort(6)	Int2StsPort(5)	Int2StsPort(4)	Int2StsPort(3)	Int2StsTim4
RegInt0Msk	0x0064	0x00	Int0MskPort(0)	Int0MskTim1	Int0MskPsc11Hz	Int0MskADC	Int0MskDoCDM	Int0MskDoCPM	Int0MskGasp	Int0MskPMMiss
RegInt1Msk	0x0065	0x00	Int1MskPort(2)	Int1MskPort(1)	Int1MskTim2	Int1MskTim3	Int1MskOpAmp	Int1MskPsc1B	Int1MskSPIStop	Int1MskSPIStart
RegInt2Msk	0x0066	0x00	Int2MskSVLD	Int2MskSlpCnt	Int2MskPort(7)	Int2MskPort(6)	Int2MskPort(5)	Int2MskPort(4)	Int2MskPort(3)	Int2MskTim4
RegInt0PostMsk	0x0067	0x00	Int0PostMskPort(0)	Int0PostMskTim1	Int0PostMskPsc11Hz	Int0PostMskADC	Int0PostMskDoCDM	Int0PostMskDoCPM	Int0PostMskGasp	Int0PostMskPMMiss
RegInt1PostMsk	0x0068	0x00	Int1PostMskPort(2)	Int1PostMskPort(1)	Int1PostMskTim2	Int1PostMskTim3	Int1PostMskOpAmp	Int1PostMskPsc1B	Int1PostMskSPIStop	Int1PostMskSPIStart
RegInt2PostMsk	0x0069	0x00	Int2PostMskSVLD	Int2PostMskSlpCnt	Int2PostMskPort(7)	Int2PostMskPort(6)	Int2PostMskPort(5)	Int2PostMskPort(4)	Int2PostMskPort(3)	Int2PostMskTim4
RegIntPortSrc	0x006A	0x00	IntPortSrc(7)	IntPortSrc(6)	IntPortSrc(5)	IntPortSrc(4)	IntPortSrc(3)	IntPortSrc(2)	IntPortSrc(1)	IntPortSrc(0)
RegEvtSts	0x006B	0x00	-	-	-	-	Evt1StsSlpCnt	Evt1StsSPI	Evt1StsADC	Evt0StsGasp
RegEvtCfG	0x006C	0x00	Evt1PostMskSC	Evt1MskSC	Evt1PostMskSPI	Evt1MskSPI	Evt1PostMskADC	Evt1MskADC	Evt0PostMskGasp	Evt0MskGasp
RegWDCfG	0x006D	0x00	WDDis	-	-	-	-	-	-	WDClear
RegWDKey	0x006E	0x00	WDKey(7)	WDKey(6)	WDKey(5)	WDKey(4)	WDKey(3)	WDKey(2)	WDKey(1)	WDKey(0)
RegWDLdValL	0x006F	0x00	WDLdValL(7)	WDLdValL(6)	WDLdValL(5)	WDLdValL(4)	WDLdValL(3)	WDLdValL(2)	WDLdValL(1)	WDLdValL(0)
RegWDLdValM	0x0070	0x80	WDLdValM(7)	WDLdValM(6)	WDLdValM(5)	WDLdValM(4)	WDLdValM(3)	WDLdValM(2)	WDLdValM(1)	WDLdValM(0)
RegWDStatL	0x0071	0x00	WDStatL(7)	WDStatL(6)	WDStatL(5)	WDStatL(4)	WDStatL(3)	WDStatL(2)	WDStatL(1)	WDStatL(0)
RegWDStatM	0x0072	0x80	WDStatM(7)	WDStatM(6)	WDStatM(5)	WDStatM(4)	WDStatM(3)	WDStatM(2)	WDStatM(1)	WDStatM(0)
RegSCCfG	0x0073	0x00	SCDis	SCStart	-	-	-	-	-	-
RegSCLdVal0	0x0074	0x00	SCLdVal0(7)	SCLdVal0(6)	SCLdVal0(5)	SCLdVal0(4)	SCLdVal0(3)	SCLdVal0(2)	SCLdVal0(1)	SCLdVal0(0)



EM6819FX-B300

RegName	Address	Init.	Bit7	Bit6	Bit5	Bit4	Bit3	Bit2	Bit1	Bit0
RegSCLdVal1	0x0075	0x80	SCLdVal1(7)	SCLdVal1(6)	SCLdVal1(5)	SCLdVal1(4)	SCLdVal1(3)	SCLdVal1(2)	SCLdVal1(1)	SCLdVal1(0)
RegSCLdVal2	0x0076	0x00	SCLdVal2(7)	SCLdVal2(6)	SCLdVal2(5)	SCLdVal2(4)	SCLdVal2(3)	SCLdVal2(2)	SCLdVal2(1)	SCLdVal2(0)
RegSCStat0	0x0077	0x00	SCStat0(7)	SCStat0(6)	SCStat0(5)	SCStat0(4)	SCStat0(3)	SCStat0(2)	SCStat0(1)	SCStat0(0)
RegSCStat1	0x0078	0x80	SCStat1(7)	SCStat1(6)	SCStat1(5)	SCStat1(4)	SCStat1(3)	SCStat1(2)	SCStat1(1)	SCStat1(0)
RegSCStat2	0x0079	0x00	SCStat2(7)	SCStat2(6)	SCStat2(5)	SCStat2(4)	SCStat2(3)	SCStat2(2)	SCStat2(1)	SCStat2(0)
RegSPICfg1	0x007A	0x03	SPIEn	SPIMode(2)	SPIMode(1)	SPIMode(0)	SPINegEdg	SPIRTO	SPIMSB1st	SPIAutoStart
RegSPICfg2	0x007B	0x00	SPISelSClk(1)	SPISelSClk(0)	SPISelSIn(2)	SPISelSIn(1)	SPISelSIn(0)	-	-	SPICompMode
RegSPISStart	0x007C	0x00	SPISStart	-	-	-	-	-	-	-
RegSPIDIn	0x007D	0x00	SPIDIn(7)	SPIDIn(6)	SPIDIn(5)	SPIDIn(4)	SPIDIn(3)	SPIDIn(2)	SPIDIn(1)	SPIDIn(0)
RegSPIDOut	0x007E	0x00	SPIDOut(7)	SPIDOut(6)	SPIDOut(5)	SPIDOut(4)	SPIDOut(3)	SPIDOut(2)	SPIDOut(1)	SPIDOut(0)
RegCacheB00	0x0280	0x00	CacheB00(7)	CacheB00(6)	CacheB00(5)	CacheB00(4)	CacheB00(3)	CacheB00(2)	CacheB00(1)	CacheB00(0)
RegCacheB01	0x0281	0x00	CacheB01(7)	CacheB01(6)	CacheB01(5)	CacheB01(4)	CacheB01(3)	CacheB01(2)	CacheB01(1)	CacheB01(0)
RegCacheB02	0x0282	0x00	CacheB02(7)	CacheB02(6)	CacheB02(5)	CacheB02(4)	CacheB02(3)	CacheB02(2)	CacheB02(1)	CacheB02(0)
RegCacheB03	0x0283	0x00	CacheB03(7)	CacheB03(6)	CacheB03(5)	CacheB03(4)	CacheB03(3)	CacheB03(2)	CacheB03(1)	CacheB03(0)
RegCacheB04	0x0284	0x00	CacheB04(7)	CacheB04(6)	CacheB04(5)	CacheB04(4)	CacheB04(3)	CacheB04(2)	CacheB04(1)	CacheB04(0)
RegCacheB05	0x0285	0x00	CacheB05(7)	CacheB05(6)	CacheB05(5)	CacheB05(4)	CacheB05(3)	CacheB05(2)	CacheB05(1)	CacheB05(0)
RegCacheB06	0x0286	0x00	CacheB06(7)	CacheB06(6)	CacheB06(5)	CacheB06(4)	CacheB06(3)	CacheB06(2)	CacheB06(1)	CacheB06(0)
RegCacheB07	0x0287	0x00	CacheB07(7)	CacheB07(6)	CacheB07(5)	CacheB07(4)	CacheB07(3)	CacheB07(2)	CacheB07(1)	CacheB07(0)
RegCacheB08	0x0288	0x00	CacheB08(7)	CacheB08(6)	CacheB08(5)	CacheB08(4)	CacheB08(3)	CacheB08(2)	CacheB08(1)	CacheB08(0)
RegCacheB09	0x0289	0x00	CacheB09(7)	CacheB09(6)	CacheB09(5)	CacheB09(4)	CacheB09(3)	CacheB09(2)	CacheB09(1)	CacheB09(0)
RegCacheB10	0x028A	0x00	CacheB10(7)	CacheB10(6)	CacheB10(5)	CacheB10(4)	CacheB10(3)	CacheB10(2)	CacheB10(1)	CacheB10(0)
RegCacheB11	0x028B	0x00	CacheB11(7)	CacheB11(6)	CacheB11(5)	CacheB11(4)	CacheB11(3)	CacheB11(2)	CacheB11(1)	CacheB11(0)
RegCacheB12	0x028C	0x00	CacheB12(7)	CacheB12(6)	CacheB12(5)	CacheB12(4)	CacheB12(3)	CacheB12(2)	CacheB12(1)	CacheB12(0)
RegCacheB13	0x028D	0x00	CacheB13(7)	CacheB13(6)	CacheB13(5)	CacheB13(4)	CacheB13(3)	CacheB13(2)	CacheB13(1)	CacheB13(0)
RegCacheB14	0x028E	0x00	CacheB14(7)	CacheB14(6)	CacheB14(5)	CacheB14(4)	CacheB14(3)	CacheB14(2)	CacheB14(1)	CacheB14(0)
RegCacheB15	0x028F	0x00	CacheB15(7)	CacheB15(6)	CacheB15(5)	CacheB15(4)	CacheB15(3)	CacheB15(2)	CacheB15(1)	CacheB15(0)
RegCacheB16	0x0290	0x00	CacheB16(7)	CacheB16(6)	CacheB16(5)	CacheB16(4)	CacheB16(3)	CacheB16(2)	CacheB16(1)	CacheB16(0)
RegCacheB17	0x0291	0x00	CacheB17(7)	CacheB17(6)	CacheB17(5)	CacheB17(4)	CacheB17(3)	CacheB17(2)	CacheB17(1)	CacheB17(0)
RegCacheB18	0x0292	0x00	CacheB18(7)	CacheB18(6)	CacheB18(5)	CacheB18(4)	CacheB18(3)	CacheB18(2)	CacheB18(1)	CacheB18(0)



EM6819FX-B300

RegName	Address	Init.	Bit7	Bit6	Bit5	Bit4	Bit3	Bit2	Bit1	Bit0
RegCacheB19	0x0293	0x00	CacheB19(7)	CacheB19(6)	CacheB19(5)	CacheB19(4)	CacheB19(3)	CacheB19(2)	CacheB19(1)	CacheB19(0)
RegCacheB20	0x0294	0x00	CacheB20(7)	CacheB20(6)	CacheB20(5)	CacheB20(4)	CacheB20(3)	CacheB20(2)	CacheB20(1)	CacheB20(0)
RegCacheB21	0x0295	0x00	CacheB21(7)	CacheB21(6)	CacheB21(5)	CacheB21(4)	CacheB21(3)	CacheB21(2)	CacheB21(1)	CacheB21(0)
RegCacheB22	0x0296	0x00	CacheB22(7)	CacheB22(6)	CacheB22(5)	CacheB22(4)	CacheB22(3)	CacheB22(2)	CacheB22(1)	CacheB22(0)
RegCacheB23	0x0297	0x00	CacheB23(7)	CacheB23(6)	CacheB23(5)	CacheB23(4)	CacheB23(3)	CacheB23(2)	CacheB23(1)	CacheB23(0)
RegCacheB24	0x0298	0x00	CacheB24(7)	CacheB24(6)	CacheB24(5)	CacheB24(4)	CacheB24(3)	CacheB24(2)	CacheB24(1)	CacheB24(0)
RegCacheB25	0x0299	0x00	CacheB25(7)	CacheB25(6)	CacheB25(5)	CacheB25(4)	CacheB25(3)	CacheB25(2)	CacheB25(1)	CacheB25(0)
RegCacheB26	0x029A	0x00	CacheB26(7)	CacheB26(6)	CacheB26(5)	CacheB26(4)	CacheB26(3)	CacheB26(2)	CacheB26(1)	CacheB26(0)
RegCacheB27	0x029B	0x00	CacheB27(7)	CacheB27(6)	CacheB27(5)	CacheB27(4)	CacheB27(3)	CacheB27(2)	CacheB27(1)	CacheB27(0)
RegCacheB28	0x029C	0x00	CacheB28(7)	CacheB28(6)	CacheB28(5)	CacheB28(4)	CacheB28(3)	CacheB28(2)	CacheB28(1)	CacheB28(0)
RegCacheB29	0x029D	0x00	CacheB29(7)	CacheB29(6)	CacheB29(5)	CacheB29(4)	CacheB29(3)	CacheB29(2)	CacheB29(1)	CacheB29(0)
RegCacheB30	0x029E	0x00	CacheB30(7)	CacheB30(6)	CacheB30(5)	CacheB30(4)	CacheB30(3)	CacheB30(2)	CacheB30(1)	CacheB30(0)
RegCacheB31	0x029F	0x00	CacheB31(7)	CacheB31(6)	CacheB31(5)	CacheB31(4)	CacheB31(3)	CacheB31(2)	CacheB31(1)	CacheB31(0)
RegCacheCfg1	0x02A0	0x00	-	-	CacheRow(5)	CacheRow(4)	CacheRow(3)	CacheRow(2)	CacheRow(1)	CacheRow(0)
RegCacheCfg2	0x02A1	0x80	NVMFastProg	-	-	-	-	CacheSector(2)	CacheSector(1)	CacheSector(0)
RegTrimOsc15M	0x02A2	0x80	TrimOsc15M(7)	TrimOsc15M(6)	TrimOsc15M(5)	TrimOsc15M(4)	TrimOsc15M(3)	TrimOsc15M(2)	TrimOsc15M(1)	TrimOsc15M(0)
RegTrimOsc2M	0x02A3	0x80	TrimOsc2M(7)	TrimOsc2M(6)	TrimOsc2M(5)	TrimOsc2M(4)	TrimOsc2M(3)	TrimOsc2M(2)	TrimOsc2M(1)	TrimOsc2M(0)
RegTrimSVLD	0x02A4	0x08	-	-	-	-	TrimSVLD(3)	TrimSVLD(2)	TrimSVLD(1)	TrimSVLD(0)
RegStsCStart	0x02A5	0x39	-	-	StsCSRReson	StsCSXtal	StsCSPad	StsCSR8k	StsCSR2M	StsCSR15M
RegStsEnOsc	0x02A6	0x06	-	-	-	StsEnReson	StsEnXtal	StsEnRC8k	StsEnRC2M	StsEnRC15M
RegCkSw1	0x02A7	0x12	CkSwSelX	CkSwStsX	CkSwSelHi(2)	CkSwSelHi(1)	CkSwSelHi(0)	CkSwStsHi(2)	CkSwStsHi(1)	CkSwStsHi(0)
RegCkSw2	0x02A8	0x24	-	-	CkSwSelLo(2)	CkSwSelLo(1)	CkSwSelLo(0)	CkSwStsLo(2)	CkSwStsLo(1)	CkSwStsLo(0)



EM6819FX-B300

2.6 PORT TERMINAL CONNECTION REFERENCE TABLE

chip Nbr	Name	Base	IRQ	ADC	Reset	VREF	VLD	OPAMP	SPI	GASP	CLOCK	Timer clock	Timer start	PWM FrqOut	
2	VSS	SUP	main VSS												
3	PB2	IO							SCLK					sig	
4	PB3	IO												sig	
5	PB4	IO							SIN					sig	
6	PB5	IO							SOUT					sig	
7	PB6	IO								GASP-SCK				sig	
8	PB7	IO								GASP-SIO				sig	
9	PA0	IO	PAIRQ0	ADC0	Reset							t1ck0_in	start1_in	sig	
10	PC0	IO	PCIRQ0	ADC1										sig	
11	PA1	IO	PAIRQ1	ADC2	Reset		VLD	OPA_Out				t2ck0_in	start2_in	sig	
12	PC1	IO	PCIRQ1	ADC3			VLD	OPA_Out				t2ck1_in	start3_in	sig	
13	PA2	IO	PAIRQ2	ADC4	Reset	Vref_ADC	VLD	OPA_INM	SIN			t3ck0_in	start4_in	sig	
14	PC2	IO	PAIRQ2	ADC5				OPA_INM	SOUT					sig	
15	PA3	IO	PAIRQ3	ADC6	Reset			OPA_INP				t4ck0_in	start5_in	sig	
16	PC3	IO	PCIRQ3	ADC7				OPA_INP				t4ck1_in	start6_in	sig	
17	VREG	SUP	use external Capacitor												
18	PA4	IO	PAIRQ4		Reset				SIN			XIN		sig	
19	PC4	IO	PCIRQ4									XOUT		sig	
20	TM	IN								GASP-Sel		ExtCk			
21	PA5	IO	PAIRQ5		Reset									sig	
22	PC5	IO	PCIRQ5				VLD							sig	
23	PC6	IO	PCIRQ6				VLD		SCLK			t1ck1_in	start7_in	sig	
24	PA6	IO	PAIRQ6		Reset	Vref_out	VLD		SCLK					sig	
25	PA7	IO	PAIRQ7		Reset		VLD		SIN					sig	
26	PC7	IO	PCIRQ7						SOUT			t3ck1_in		sig	
27	PB0	IO							SIN					sig	
28	PB1	IO												sig	
29	VSUP	SUP													

2.7 AVAILABLE PACKAGES

28-Lead TSSOP
4.40mm body
EM6819FX-B300

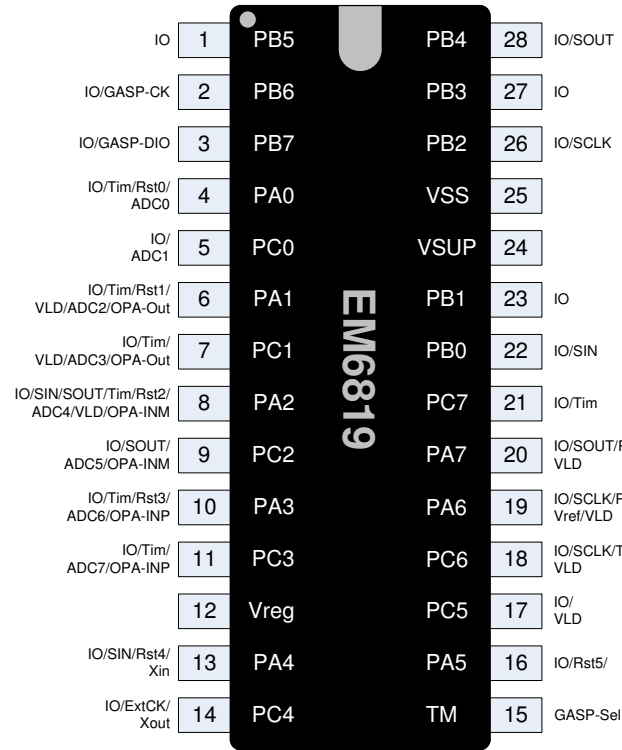

20-Lead TSSOP
4.40mm body
EM6819FX-B300

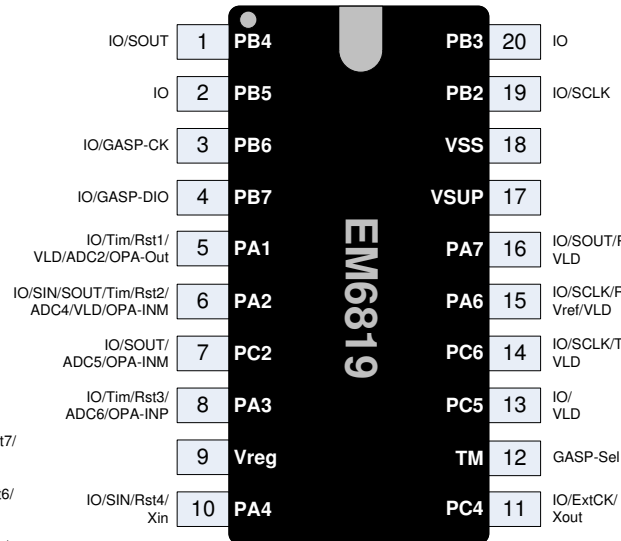

16-Lead TSSOP
4.40mm body
EM6819FX-B300

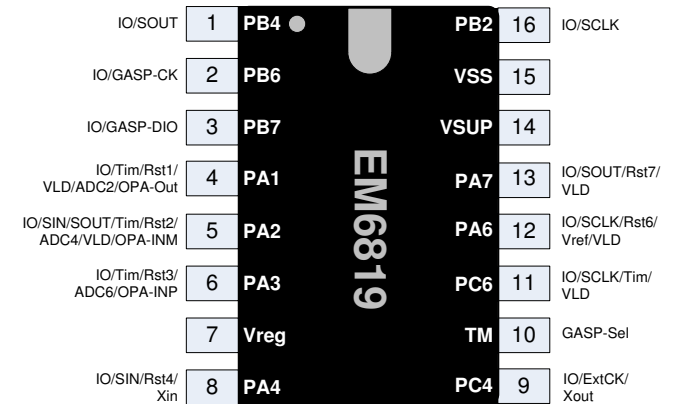

20 Lead QFN
4x4mm body
EM6819FX-B300

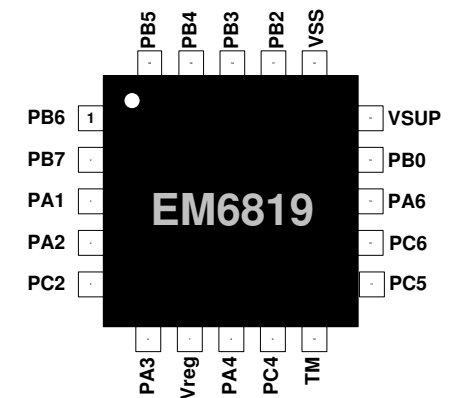

3. CPU CORE CR816

The full detail of the used CoolRISC 816L core is described in [1].

A brief overview of its highlights is given below.

- 8-bits RISC register-memory processor based on a Harvard architecture
- 3 stage pipeline (no delay slots or branch delays)
- 176 Kbytes max Program Memory size (64 KInstruction, 22 bit wide)
- 64 Kbytes max Data Memory size (organized in 256 x 256 Kbytes pages)
- 8 max hardware subroutines and unlimited software subroutines
- 8 bit x 8 bit hardware multiplier
- 5 addressing modes
 - direct addressing
 - indexed addressing with immediate offset
 - indexed addressing with register offset
 - indexed addressing with post-incrementation of the offset
 - indexed addressing with pre-decrementation of the offset
- 16 CPU internal registers (Accu, general purpose, Index, offset, status)

The Instruction Set is composed of

- Branch Instructions
- Transfer Instructions
- Arithmetic and Logical Instructions
- Special Instructions

Unlike most RISC processors, the CR816L provides instructions which can perform arithmetic and logical operations with operands stored either in the data memory or in internal registers.

Similarly to classic 8-bit processors, the CR816L architecture provides an accumulator located at the ALU output that stores the last ALU result.

All arithmetic operations support both signed and unsigned operations.

Mnemonic	ALU instruction	Description
ADD	yes	Addition.
ADDC	yes	Addition with carry.
AND	yes	Logical AND.
CALL	no	Jump to subroutine.
CALLS	no	Jump to subroutine, using <i>ip</i> as return address.
CMP	yes	Unsigned compare.
CMPA	yes	Signed compare.
CMVD	yes	Conditional move, if carry clear.
CMVS	yes	Conditional move, if carry set.
CPL1	yes	One's complementation.
CPL2	yes	Two's complementation.
CPL2C	yes	Two's complementation with carry.
DEC	yes	Decrementation.
DECC	yes	Decrementation with carry.
HALT	no	Halt mode selection.
INC	yes	Increment.
INCC	yes	Increment with carry.
Jcc	no	Conditional jump.
MOVE	yes	Data move.
MUL	yes	Unsigned multiplication.
MULA	yes	Signed multiplication.
NOP	no	No operation.
OR	yes	Logical OR.
POP	no	Pop <i>ip</i> index from hardware stack.
PUSH	no	Push <i>ip</i> index onto hardware stack.
RET	no	Return from subroutine.
RETI	no	Return from interrupt.
SFLAG	yes	Save flags.
SHL	yes	Logical shift left.
SHLC	yes	Logical shift left with carry.
SHR	yes	Logical shift right.
SHRA	yes	Arithmetic shift right.
SHRC	yes	Logical shift right with carry.
SUBD	yes	Subtraction (op1 - op2).
SUBDC	yes	Subtraction with carry (op1 - op2).
SUBS	yes	Subtraction (op2 - op1).
SUBSC	yes	Subtraction with carry (op2 - op1).
TSTB	yes	Test bit.
XOR	yes	Logical exclusive OR.

3.1 PM_MISS FUNCTION (FLASH READ MONITOR)

In extreme conditions (very low temperature and $ck_hi > 15\text{MHz}$) the NVM time access could be longer than a CPU cycle. In this case a `pm_miss` is generated, meaning that the CPU will automatically wait an additional cycle before to fetch the current instruction read in the NVM. Doing so, it guarantees that the system never fails even if the CPU is running faster than the NVM. Interrupt of priority 0 **Int0StsPmMiss** is generated on each `pm_miss`.

4. NVM MEMORY

4.1 INTRODUCTION

The circuits Non Volatile Memory (NVM) is used to store the application software but it may also be used to store data (constants or variables). The same physical memory area is shared between the instruction code and the data's. The boundary in this general purpose NVM memory (GPNVM) between the instruction code and the data's is not fixed in detail by hardware but given by the linker after compilation.

The data read access in NVM (see chapter "Read data in NVM") is executed as a simple register access.

The data write access in NVM (see chapter "Write data in NVM") is not executed with a simple MOVE. It is necessary to store the data's in an intermediate memory called RAM cache and to execute an API sub-routine in the ROM.

NVM data read access needs 2 CPU cycles, 1st the read instruction followed with an NVM data access. During the data access phase the CPU is in a wait state. The CR816 instruction is a 22 bits wide bus. When the CPU reads the NVM through the data's bus, 22 bits are read but only 2 bytes (16-bits) are accessed (the other 6 bits are used for verification).

Note:

If the additional 6 bits are not equal to 0x3F, the read access to the previous read pair of bytes is denied. The system interprets this access as a forbidden access to the program memory area (code protection feature)

Instruction read by CPU is straight forward; all instruction read take 1 CPU cycle.

4.2 NVM ARCHITECTURE

The NVM is divided in 6 sectors, each sector is divided in 64 rows and each row contains either 16 instructions or 32 data bytes. A single row shall not share instructions and data bytes. From the CPU data bus interface point of view, the NVM is mapped from address 0x4000 to 0x6FFF as shown in the following diagram.

Figure 3, NVM architecture

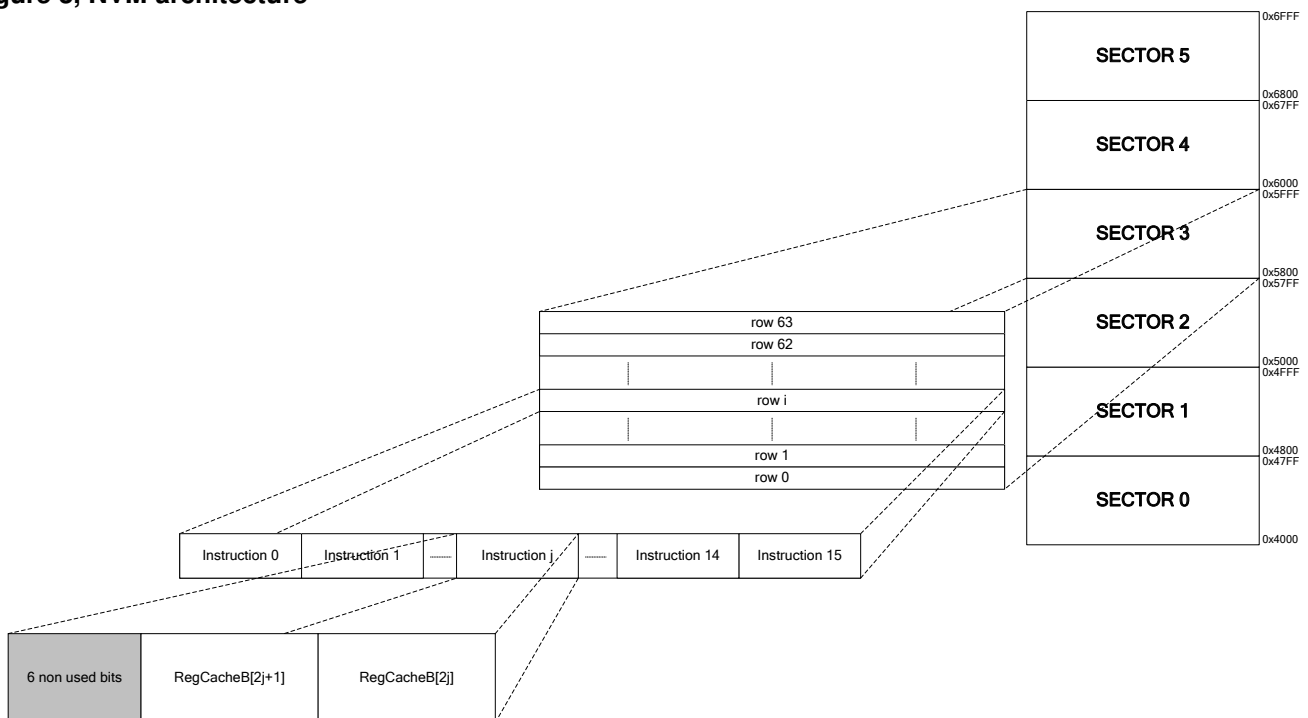

Note:

The row 63 and 62 of sector 5 is reserved for trimming word and unique ID code. Write access in this row is denied. The row 61 of sector 5 is used for NVM memory dump and external read/write access protection.

4.3 RAM CACHE

The RAM cache is an image of 1 row of the NVM. The write access to the NVM is done row by row. After selecting the row and the sector to access, the RAM cache contents are copied in the selected row by the CPU executing a CALL of the API sub-routine in the ROM.

The RAM cache is mapped as follows:

DM address (HEX)	RAM cache byte
0x0280	RegCacheB00
0x0281	RegCacheB01
0x0282	RegCacheB02
0x0283	RegCacheB03
0x0284	RegCacheB04
0x0285	RegCacheB05
0x0286	RegCacheB06
0x0287	RegCacheB07
0x0288	RegCacheB08
0x0289	RegCacheB09
0x028A	RegCacheB10
0x028B	RegCacheB11
0x028C	RegCacheB12
0x028D	RegCacheB13
0x028E	RegCacheB14
0x028F	RegCacheB15
0x0290	RegCacheB16
0x0291	RegCacheB17
0x0292	RegCacheB18
0x0293	RegCacheB19
0x0294	RegCacheB20
0x0295	RegCacheB21
0x0296	RegCacheB22
0x0297	RegCacheB23
0x0298	RegCacheB24
0x0299	RegCacheB25
0x029A	RegCacheB26
0x029B	RegCacheB27
0x029C	RegCacheB28
0x029D	RegCacheB29
0x029E	RegCacheB30
0x029F	RegCacheB31

4.4 WRITE DATA IN NVM

Only erased memory space can be written. Write applies always to one full row. Erase and write operations are handled by API-subroutines.

4.4.1 ROW AND SECTOR SELECTION

Write access is done row by row (32 bytes at a time). The row selection needs to be done before calling the API subroutine.

RegCacheCfg1[5:0] in address 0x02A0 is the row pointer from, it may take values from 0x00 and 0x3F (row 63).

RegCacheCfg2[2:0] in address 0x02A1 is the sector pointer, it may take values from 0x00 and 0x05.

4.4.2 FAST/SLOW OPERATION

The user has the choice to execute the erase and write access either in normal or in slow mode. The 'slow' API routines will take more time to execute but will draw instantly less current.

4.4.3 ERASE

Erase is a mandatory step before write. The NVM erase state is high, write state low. Only Row erase or sector erase are allowed, below table summaries the available API routines

sub-routines	Description	Duration
<i>erase_sector_apl</i>	Erase the selected sector [4:0]. Erase sector 5 is denied.	2 ms
<i>erase_sector_slow_apl</i>	Erase the selected sector [4:0] in slow mode. Erase sector 5 is denied.	3 ms
<i>erase_row_apl</i>	Erase the selected row [63:0] in the selected sector [5:0]. Erase row 63 & 62 in sector 5 is denied.	2 ms
<i>erase_row_slow_apl</i>	Erase the selected row [63:0] in the selected sector [5:0] in slow mode. Erase row 63 & 62 in sector 5 is denied.	3 ms

Accessing above routines will use the sector and row pointers as defined in **RegCacheCfg2,1**

4.4.4 WRITE

Before writing a specific row, the RAM cache needs to get the new data, the sector and row pointers need to be set according to the desired NVM location, and once everything setup, the CPU may call one of the below listed API subroutines to write the NVM row. Write access is row by row only.

Write_row_x API routines include also the erase row. It is therefore not necessary to erase the row before.

Write_only_x routines do not include the erase. These routines may only be used if the addressed row was erased earlier.

sub-routines	Description	Duration
<i>write_row_apl</i>	Erase and write the selected row [63:0] in the selected sector [5:0]. Access row 63 & 62 in sector 5 is denied.	3 ms
<i>write_row_slow_apl</i>	Erase and write the selected row [63:0] in the selected sector [5:0] in slow mode. Access row 63 & 62 in sector 5 is denied.	4.5 ms
<i>write_only_apl</i>	Only write the selected row [63:0] in the selected sector [5:0]. Write row 63 & 62 in sector 5 is denied.	1 ms
<i>write_only_slow_apl</i>	Only write the selected row [63:0] in the selected sector [5:0] in slow mode. Write row 63 & 62 in sector 5 is denied.	1.5 ms

Note:

It is not allowed to re-write more a given row without prior erase

4.5 ROW 61 SECTOR 5

It is possible to protect the NVM against undesired external access through the GASP interface.

There are two kind of protection:

Lock: No code or data modification from GASP are allowed; Sector and row erase, write_row and write_only are impossible. Specific GASP reads remain possible in specific user authorized areas.

TLock: Same as Lock but in addition: It's impossible to analyse the NVM data over the GASP interface even with the factory test modes.

TLock and Lock are bytes store in row 61 of sector 5. TLock is at address 0x6FDF (**RegCacheB31**) and 0x6FDE (**RegCacheB30**). They are active (NVM protected) when they are equal to 0x4E.

As mentioned above, it is possible to open external access (GASP access) in read mode in a part of the NVM. The start and stop address of this window is stored in the row 61 of sector 5. The stop and start address are mapped as follows:

Limit	DM address	RAM cache
Start address MSB	0x6FDD	RegCacheB29
Start address LSB	0x6FDC	RegCacheB28
Stop address MSB	0x6FDB	RegCacheB27
Stop address LSB	0x6FDA	RegCacheB26

The rest of the row 61 of sector 5 is reserved and shall not be accessed by the user.

4.6 ROW 62 SECTOR 5

The row 62 of sector 5 contains different trimming values that are not copied automatically after reset but available to the user. The structure of this row is as follows:

DM Address	Mapped in RAM cache	Function
0x6FDF:D2	RegCacheB31:16	Reserved
0x6FD1	RegCacheB17	Contains MSB[10:8] of ADC offset trim with range 4/13
0x6FD0	RegCacheB16	Contains LSB[7:0] of ADC offset trim with range 4/13
0x6FCF	RegCacheB15	Contains MSB[10:8] of ADC offset trim with range 6/13
0x6FCE	RegCacheB14	Contains LSB[7:0] of ADC offset trim with range 6/13
0x6FCD	RegCacheB13	Contains MSB[10:8] of ADC offset trim with range 9/13
0x6FCC	RegCacheB12	Contains LSB[7:0] of ADC offset trim with range 9/13
0x6FCB	RegCacheB11	Contains MSB[10:8] of ADC offset trim with range 13/13
0x6FCA	RegCacheB10	Contains LSB[7:0] of ADC offset trim with range 13/13
0x6FC9	RegCacheB9	Contains MSB[10:8] of ADC offset using temperature sensor
0x6FC8	RegCacheB8	Contains LSB[7:0] of ADC offset using temperature sensor
0x6FC7:C6	RegCacheB7:6	Reserved
0x6FC5	RegCacheB5	Contains MSB[10:8] of temperature sensor result at 60°C
0x6FC4	RegCacheB4	Contains LSB[7:0] of temperature sensor result at 60°C
0x6FC3	RegCacheB3	Contains MSB[10:8] of temperature sensor result at 25°C
0x6FC2	RegCacheB2	Contains LSB[7:0] of temperature sensor result at 25°C
0x6FC1	RegCacheB1	Contains RC 15MHz trimming value at 25°C
0x6FC0	RegCacheB0	Contains RC 2MHz trimming value at 25°C

The user can not update the values in sector 5 row 62, write access is denied.

4.6.1 TEMPERATURE TOLERANCE

Above calibration values are measured under the following temperature tolerances:

Nominal temperature	Tolerance
40°C	+/- 2°C
90°C	+/- 2°C

Note:

These tolerances have no influence on the RC temperature compensation procedure. It depends only on the linearity of the RC trim and temperature sensor.

4.7 ROW 63 SECTOR 5

The row 63 of sector 5 contains the different trimming values used by the system to position the device at power-up and after each reset. It contains also one unique ID code and a CRC code of the row to check at any time the data integrity of this row.. The structure of this row is as follows:

DM Address	Mapped in RAM cache	Function
0x6FFF:FE	RegCacheB31:30	Reserved
0x6FFD	RegCacheB29	Contains RC 15MHz oscillator trimming byte @ 40°C
0x6FFC	RegCacheB28	Contains RC 2MHz oscillator trimming byte @ 40°C
0x6FFB:FA	RegCacheB27:26	Reserved
0x6FF9	RegCacheB25	Contains VLD trimming value
0x6FF8:F3	RegCacheB24:19	Reserved
0x6FF2:F1	RegCacheB18:17	CRC calculated on 29:19,14
0x6FF0:EB	RegCacheB16:11	Reserved
0x6FEA:E4	RegCacheB10:4	Unique ID code
0x6FE3:E0	RegCacheB3:0	Reserved

The user can not update the values in sector 5 row 63 & 62, write access is denied.

4.8 READ DATA IN NVM

Read access to NVM memory is done like a register read access. However only data values may be read, any access to instruction code through the data memory bus in read mode is denied. The limit between data values and instruction code is defined by the linker during compilation. As it is mentioned above, the NVM is mapped in possible data memory areas as follows:

Sector	Max DM address	DM address (HEX)
0		0x4000 to 0x47FF
1	0x4FFF is max for F2 type	0x4800 to 0x4FFF
2		0x5000 to 0x57FF
3	0x5FFF is max for F4 type	0x5800 to 0x5FFF
4		0x6000 to 0x67FF
5	0x6FFF is max for F6 type	0x6800 to 0x6FFF

When NVM is accessed through the data memory bus, the execution of software is stopped during one cycle (wait state) as the data memory is shared with program memory. Reading NVM accesses always 22 bits split in three elements (2 bytes and 6bits). The two bytes are stored in a buffer; the 6 additional bits discarded. If this pair of bytes is accessed successively, the data memory buffer is read directly and the NVM is not accessed (no wait cycle).

4.9 ROW TO CACHE

When the user wants to change one byte or even one bit in the NVM, he has to write the entire row where the modification has to be done.

To simplify this procedure, a sub-routine able to dump one full row to the RAM cache exists: *nvm_to_cache_apl*. The user has to specify the row (**RegCacheCfg1**) and the sector (**RegCacheCfg2**) pointers. After modifying the byte or the bit directly in the RAM cache he can write it's contents back into the NVM using sub-routine *write_row_apl*.

Figure 4, Row to Cache flowchart

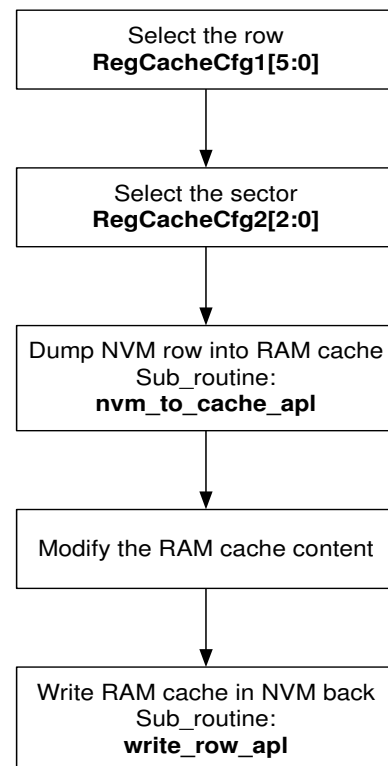

4.9.1 NVM CONFIGURATION REGISTERS

0x02A0		RegCacheCfg1			NVM Row Cache Configuration - 1
Bits	Name	Type	ResVal	ResSrc	Description
7:6	-	NI	-	-	Not implemented
5:0	CacheRow	RW	0x00	ResSys	NVM Row Cache: Row number of Sector (CacheSector)

0x02A1		RegCacheCfg2			NVM Row Cache Configuration - 2
Bits	Name	Type	ResVal	ResSrc	Description
7	NVMFastProg	RW	1	ResSys	NVM fast programming mode
2:0	CacheSector	RW	'000'	ResSys	NVM Row Cache: Sector number

Note:

The bit **NVMFastProg** is automatically set in the ROM API routine. It is set to '0' automatically when a slow operation is called, otherwise it is set to '1'.

0x0280 to 0x029F		RegCacheB00 to RegCacheB31			NVM Row Cache Byte-0 to NVM Row Cache Byte-31
Bits	Name	Type	ResVal	ResSrc	Description
7:0	CacheB00	RW	0x00	ResSys	NVM Row Cache Byte-0

7:0	CacheB31	RW	0x00	ResSys	NVM Row Cache Byte-31

5. CRC CHECK

5.1 CRC CHECK ON PROGRAM AREA

It is possible, at any time, to check the content of the NVM by calculating the CRC on the program memory. A sub-routine dedicated for this procedure exists: *calc_crc_code_apl*. The start and stop address of the area to check shall be given as parameter to the sub-routine as follows:

Parameter	Location (CPU Index registers)
CRCStartAddrMSB	r3
CRCStartAddrLSB	r2
CRCStopAddrMSB	r1
CRCStopAddrLSB	r0

CRCStopAddr shall be higher to CRCStartAddr otherwise the routine fails and the result is not guaranteed. The full NVM memory range in program memory area is mapped as follows:

Sector	PM address (HEX)
0	0x0000 to 0x03FF
1	0x0400 to 0x07FF
2	0x0800 to 0x0BFF
3	0x0C00 to 0x0FFF
4	0x1000 to 0x13FF
5	0x1400 to 0x17FF

The CRC made on program memory checks all the content of the NVM including the 6 additional bits that are not accessed through the data memory bus.

Note:

The user can make a CRC on the full NVM including the row 63 & 62 of sector 5. But in this case the CRC will not be constant between different devices.

5.2 CRC CHECK ON DATA AREA

It is possible, at any time, to check the content of the NVM by calculating the CRC on the data memory area. A sub-routine dedicated for this procedure exists: *calc_crc_code_apl*. The start and stop address of the area to check shall be given as parameter to the sub-routine as follows:

Parameter	Location (CPU Index registers)
CRCStartAddrMSB	r3
CRCStartAddrLSB	r2
CRCStopAddrMSB	r1
CRCStopAddrLSB	r0

CRCStopAddr shall be higher to CRCStartAddr otherwise the routine fails and the result is not guaranteed. The full NVM memory range in data memory area is mapped as follows:

Sector	DM address (HEX)
0	0x4000 to 0x47FF
1	0x4800 to 0x4FFF
2	0x5000 to 0x57FF
3	0x5800 to 0x5FFF
4	0x6000 to 0x67FF
5	0x6800 to 0x6FFF

The CRC made on data memory does not check all the content of the NVM because it excludes the 6 additional bits. It should be used to check constant tables for instance and not the program code integrity.

The CRC calculation on data is also possible in the RAM area which is mapped on the following addresses:

Block	DM address (HEX)
RAM	0x0080 to 0x027F

6. ROM API ROUTINES

The circuit has a ROM memory used for the following purposes: Refer also to [2].

- System Boot sequence
- Erase/write operation in NVM
- Dump NVM row into RAM cache
- CRC calculation on NVM or RAM
- ISP functions (Program loading, CRC check)

6.1 BOOT SEQUENCE

This sequence runs after any reset. Depending on the reset source, the boot sequence can change as follows:

Reste source	Description	Duration
Start-up	Power-up (power check) All trimming value are copied from NVM into the related registers	5 ms
ResAna	All trimming value are copied from NVM into the related registers	3.5 ms
ResSys	No trimming value are copied from NVM into the related registers.	1 ms

At the end of the boot sequence the watchdog is cleared. The user application software starts. All registers have the value as described in the register map depending what reset source is the cause of the boot sequence.

6.2 SUB-ROUTINES USED FOR APPLICATION

Using sub-routine in ROM API has an impact on the execution time and the memory. The following table shows for each application routine the number of CPU instructions needed to execute the sub-routine and the addresses in RAM memory used by the sub-routine “software stack” that cannot be recovered.

ROM API sub-routine does not use any fixed RAM address for parameter storage. All local variables needed by any of the application sub-routine are stored on the software stack, thus the application programmer shall ensure that:

1. The software stack pointer points to the RAM before any call of the application routine. The software stack pointer is i3 register of CR816. The i3 stack pointer is not initialised by the ROM SW boot sequence. It is under the programmer responsibility to initialise it after boot sequence.
2. The application does not use the the memory in range i3 points too. Depending on the sub-routine, this range can be from i3-21 to i3. All data stored in this range before calling the sub-routine may be lost. It is advised to reserve 22 bytes for software stack in RAM to ensure that any sub-routine will never erase important data.

Routine name	Stack requirements (bytes)	Execution time
<i>cacl_crc_code_apl</i>	12 bytes	11.2N + 66 (-3% ; +7%) instructions N = stop_address – start_address + 1
<i>cacl_crc_data_apl</i>	10 bytes	6N + 64 (-4% ; +3%) instructions N = stop_address – start_address + 1
<i>erase_row_apl</i>	22 bytes	2 ms (no fixed number of instruction)
<i>erase_row_slow_apl</i>	22 bytes	3 ms (no fixed number of instruction)
<i>erase_sector_apl</i>	22 bytes	2 ms (no fixed number of instruction)
<i>erase_sector_slow_apl</i>	22 bytes	3 ms (no fixed number of instruction)
<i>nvm_to_cache</i>	14 bytes	351 instructions
<i>write_only_apl</i>	22 bytes	1 ms (no fixed number of instruction)
<i>write_only_slow_apl</i>	22 bytes	1.5 ms (no fixed number of instruction)
<i>write_row_apl</i>	22 bytes	3 ms (no fixed number of instruction)
<i>write_row_slow_apl</i>	22 bytes	4.5 ms (no fixed number of instruction)
<i>get_def</i>		Copy's row 63 in RAM cache
<i>get_trim</i>		Copy's row 62 in RAM cache

7. RAM

RAM memory size is 512 bytes mapped in the data memory bus. It can be divided in two parts: the first part accessible with direct addressing instruction and the second part not accessible by direct addressing instructions as describe on the following table:

DM address (HEX)	Addressing
0x0080 to 0x00FF	Direct (128 Bytes)
0x0100 to 0x0280	Indirect (384 Bytes)

In any condition the RAM is accessed in a single CPU cycle for write and read access.

Note:

For any information concerning the direct and indirect addressing, refer to the CR816-DL documentation.[1]

8. RESET CONTROLLER

The reset controller collects all different reset sources and initializes the needed peripheral registers. Refer to the individual peripheral register mapping tables to see which reset is initializing a specific register.

Some of the reset sources are maskable to prevent undesired system reinitialization.

After any reset the circuit will perform a power check and go to active mode. Then the reset status bits can be read to identify the reset source.

8.1 RESET SOURCES

Possible reset source signals are:

POR	Power on reset, non-maskable The fully internal POR cell will initialize the full circuit at power-up or if the supply voltage falls below VPOR voltage.
ResPA	User defined Port A terminal reset function, maskable. Any port A terminal may trigger reset.
ResWD	Watchdog timer reaching 0, maskable. Logic watchdog reset running on the internal 8kHz Oscillator.
ResBO	Brown out reset at low regulated voltage, maskable.
ResBE	CoolRISC bus error when trying to access non-valid instruction space, non-maskable.
ResGASP	Entering Gasp modes (ISP, DoC), non-maskable. This reset initializes the circuit prior to programming or debugging.

8.2 RESET SIGNALS

A combination of the above mentioned reset sources are used to initialize the different peripheral registers. These reset signals are **POR**, **ResAna**, **ResSys**.

8.2.1 POR

All the registers are initialized by the power on reset circuitry (POR)

8.2.2 RESANA

ResAna signal will initialize all reset enable bits, the port A input and output enable bits, the port A debouncer selection bits, all trim bits and the analog configuration settings for the Opamp.

ResAna = **Por** OR **ResWD** OR **ResBE** (logical OR combination)

8.2.3 RESSYS

ResSys signal initializes all remaining data memory registers, except the RAM which needs to be initialized by the user software if needed.

ResSys = **Por** OR **ResWD** OR **ResBE** OR **ResPA** OR **ResGasp** OR **ResBO**

8.2.4 RESET FLAGS

All reset flags are in the Reset flag register: **RegResFlg** and placed as follows

The **ResFlgPA** bit is asserted by reset from PortA.

The **ResFlgWD** bit is asserted by reset from Watchdog.

The **ResFlgBO** bit is asserted by reset from Brownout.

The **ResFlgGasp** bit is asserted by reset from GASP.

The **ResFlgBE** bit is asserted by reset from CoolRisc Bus-error detection.

8.3 RESET REGISTERS

0x0000		RegSysCfg1			System Configuration - 1
Bits	Name	Type	ResVal	ResSrc	Description
7	SelSleep	RW	0	ResSys	Select Sleep mode on Halt
6:5	-	NI	0		
4	EnBrownOut	RW	1	ResAna	Enable Brown Out
3:2	XtalCldStart	RW	'00'	ResSys	Select Xtal Osc. ColdStart length
1	StdByFastWkUp	RW	0	ResSys	Stand-by mode fast Wakeup
0	-	NI	0		

0x0001		RegEnResPA			Enable Reset by PortA bits
Bits	Name	Type	ResVal	ResSrc	Description
7:0	EnResPA	RW	0x00	ResAna	Enable Reset by PortA bits

0x0006		RegResFlg			Reset Flags
Bits	Name	Type	ResVal	ResSrc	Description
7	ResFlgPA	ResFlg	0	POR	Flag Reset from Port-A
6	ResFlgWD	ResFlg	0	POR	Flag Reset from WatchDog
5	ResFlgBO	ResFlg	0	POR	Flag Reset from Brown-Out
4	ResFlgGasp	ResFlg	0	POR	Flag Reset from GASP
3	ResFlgBE	ResFlg	0	POR	Flag Reset from CoolRISC Bus-Error
0	-	NI	0		

9. OSCILLATOR AND CLOCKING STRUCTURE

The circuit contains

- 3 independent fully internal RC oscillators,
- 15Mhz factory pretrimmed
- 2Mhz factory pretrimmed
- 8kHz
- Either one of these external clock sources
 - 32 KHz watch crystal oscillator (Crystal extern). Mapped on terminals PA4, PC4.
 - 4 MHz Crystal or Resonator oscillator (Crystal or Resonator extern). Mapped on terminals PA4, PC4.
 - External high or Low frequency clock input. Mapped on terminal PC4.

The oscillator source can be changed on the fly to always use the appropriate oscillator and clock setting according to the desired speed for i.e high speed calculation or low speed controlling, and hence optimise the power consumption.

The circuit will always start-up on the 2MHz RC Oscillator.

All circuit internal clocks are derived from the above mentioned oscillators. These clock sources may be predivided locally for optimum speed and power.

Figure 5; oscillator and clock selection architecture

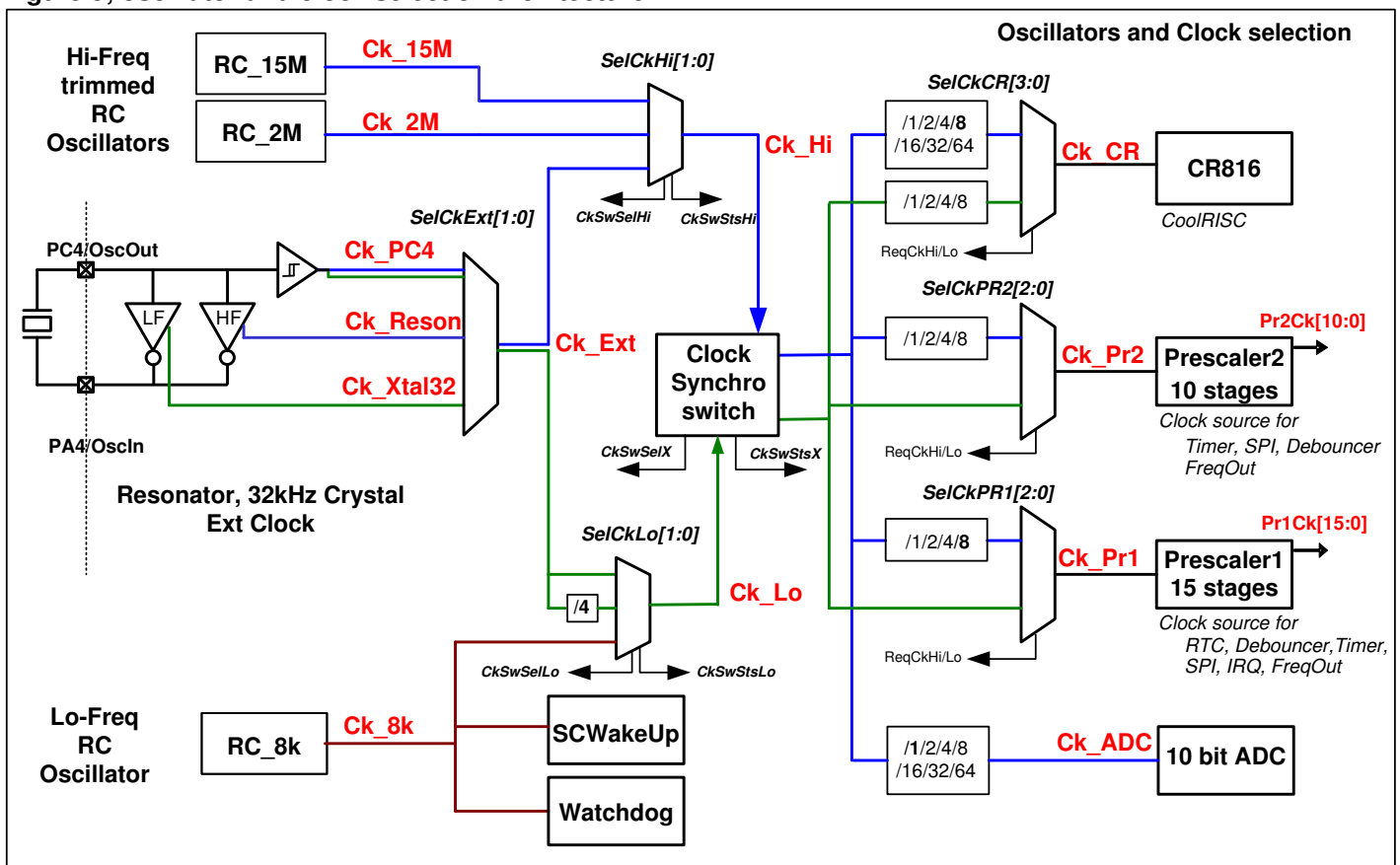

The RC15Mhz **Ck_15M** and RC_2Mhz **Ck_2M** oscillators are factory pretrimmed, the RC_8kHz **Ck_8k** oscillator is the only clock source for the watchdog and the sleep counter reset function, but can also be used as a very low system clock. The RC_8kHz low frequency oscillator is not trimmed.

On the PA4 and PC4 an external 32 KHz Crystal **Ck_Xtal** or 4MHz Resonator/Crystal **Ck_Reson** oscillator can be connected or one may have an external clock input **Ck_PC4** on PC4. The selected output clock signal is **Ck_Ext**.

The **Ck_Hi** clock signal can come from the 15MHz RC, 2MHz RC, 4MHz Resonator/Crystal or the external high frequency clock input on PC4.

The **Ck_Lo** clock signal can come from the 32 KHz Crystal oscillator, divided 32 KHz, 8 kHz RC or the low frequency external clock on PC4; it is synchronized with the high frequency clock **Ck_Hi** if present. **Ck_Lo** clock synchronization

with **Ck_Hi** allows fully synchronous circuit operation. The synchronization is disabled if the **Ck_Hi** or divided **Ck_Hi** clock is not used by any periphery.

The CPU input clock **Ck_CR** is derived from either divided or undivided **Ck_Hi** or **Ck_Lo**.

The Prescaler 1 **Ck_Pr1** and Prescaler 2 **CkPr2** input clock is derived from either divided or undivided **Ck_Hi** or direct **Ck_Lo**.

The ADC input clock **Ck_ADC** is derived from either divided or undivided **Ck_Hi** clock signal.

9.1 EXTERNAL CLOCK SELECTION

The External Component or Input clock source **Ck_Ext** is selected by register **RegClockCfg1** bits **SelCkExt** as follows:

SelCkExt	Input	Used PADs	Description	Frequency	
00	-	-	No clock selection	none	
01	Ck_Xtal	PA4, PC4	Xtal	32 KHz	
10	Ck_Reson	PA4, PC4	Resonator	4 MHz	
11	Ck_PC4	PC4, PCInpE[4]='1'	External Clock input	Used for: Ck_Hi	Min: Ck_Lo * 8; Max: 15 MHz
				Used for: Ck_Lo	Max: Ck_Hi / 8; Min: 0 Hz

The default external clock source after system reset (**ResSys**) is "00" - None. The **Ck_Ext** clock signal is tied low. Before using an external clock input source one shall configure the necessary PA4 PC4 pads as analog inputs in case of external XTAL or Resonator, and as logic input with **PCInpEn[4]=1** in case of external PC4 clock input. The external clock input on PC4 has min/max frequencies depending on its future use as **Ck_Hi** or **Ck_Lo** clock source; refer to the table above for the limits.

9.2 INTERNAL HIGH AND LOW FREQUENCY CLOCK SELECTION

The high **Ck_Hi** and low **Ck_Low** system frequencies can be selected independently but some restrictions for apply if connecting the external clock source.

The High Frequency clock **Ck_Hi** is selected according to the register **RegClockCfg1** bits **SelCkHi** as follows:

SelCkHi	Ck_Hi Source	Select signal
00	Ck_15M	SelRC15M
01	Ck_2M	SelRC2M
10	Ck_Ext	SelExt
11	Ck_2M	SelRC2M

The default **Ck_Hi** clock source after system reset (**ResSys**) is **Ck_2M**.

The Low Frequency clock **Ck_Lo** is selected according to the register **RegClockCfg1** bits **SelCkLo** as follows:

SelCkLo	Ck_Lo Source	Select signal
00	Ck_Ext	SelExt
01	Ck_Ext Divided by 4 (Ck_Ext/4)	SelExt
10	Ck_8k	SelRC8k
11	Ck_8k	SelRC8k

The default **Ck_Lo** clock source after system reset (**ResSys**) shall be **Ck_8k**.

Note:

If **Ck_Hi** or **Ck_Lo** are switched from external clock (**SelExt** active) to **Ck_15M**, **Ck_2M** or **Ck_8k** the **SelCkExt** selection must not be changed until the status bits for the selected **Ck_Hi** external clock **RegCkSw1.CkSwStsHi** or **Ck_Lo** external clock **RegCkSw2.CkSwStsLo** has changed to '0'

9.2.1 EXTERNAL CLOCK SELECTION RESTRICTIONS

The external clock source selection for both high and low frequency clocks is very flexible, however some restrictions apply:

The external clock must not be connected to both **Ck_Hi** and **Ck_Lo** at the same time.

Allowed usage for external clock input on either high or low frequency domain:

External Clock source		Allowed configuration
SelCkExt	Source	
00	None	None
01	Xtal	Ck_Lo: (SelCkLo == 00 SelCkLo == 01) && SelCkHi !=10 (Ck_Hi on RC Osc and Ck_Lo on either Ck_Ext or Ck_Ext/4)
10	Renonator	Ck_Hi: SelCkHi == 10 && (SelCkLo != 00 && SelCkLo != 01) (Ck_Hi on Ck_Ext and Ck_Lo on Ck_8k)
11	PC4	Ck_Lo: (SelCkLo == 00 SelCkLo == 01) && SelCkHi !=10 (Ck_Hi on RC Osc and Ck_Lo on either Ck_Ext or Ck_Ext/4) Ck_Hi: SelCkHi == 10 && (SelCkLo != 00 && SelCkLo != 01) (Ck_Hi on Ck_Ext and Ck_Lo on Ck_8k)

9.2.2 CPU CLOCK SELECTION

The CPU input clock **Ck_CR** is derived from divided or undivided **Ck_Hi** or **Ck_Lo** input clock. Below table is an overview of the different CPU clocking possibilities. The CPU clock divider selection is done in register **RegClockCfg2** bits **SelCkCR**.

SelCkCR	CoolRisc Clock
0000	Ck_Hi (divided by 1)
0001	Ck_Hi divided by 2
0010	Ck_Hi divided by 4
0011	Ck_Hi divided by 8 (default)
0100	Ck_Hi divided by 16
0101	Ck_Hi divided by 32
0110	Ck_Hi divided by 64
0111	Ck_Hi divided by 8
1000	Ck_Lo (divided by 1)
1001	Ck_Lo divided by 2
1010	Ck_Lo divided by 4
1011	Ck_Lo divided by 8
1100	Ck_Lo (divided by 1)
1101	Ck_Lo (divided by 1)
1110	Ck_Lo (divided by 1)
1111	Ck_Lo (divided by 1)

The default CR clock source after system reset (**ResSys**) is **Ck_Hi** divided by 8 (selection 0x3).

The CPU instruction execution cycle corresponds to half the **Ck_CR** clock frequency. 2 MHz input clock results in 1 MIPS.

ReqCkHi or **ReqCkLo** signals are asserted to the Hi- or Low frequency clock switches depending of the CR multiplexer selection.

9.2.3 PRESCALER1 CLOCK SELECTION

The Prescaler1 input clock **Ck_Pr1** is derived from divided or undivided **Ck_Hi** or **Ck_Lo** input clock. Below table is an overview of the different prescaler1 clocking possibilities. The prescaler clock divider selection is done in register **RegClockCfg3** bits **SelCkPr1**.

SelCkPr1	Prescaler1 Clock
000	Ck_Hi (divided by 1)
001	Ck_Hi divided by 2
010	Ck_Hi divided by 4
011	Ck_Hi divided by 8 default
100	Ck_Lo (divided by 1)
Others	Ck_Hi divided by 8

The default Prescaler1 clock source after system reset (**ResSys**) shall be **Ck_Hi** divided by 8 (selection 0x3).

ReqCkHi or **ReqCkLo** signals are asserted to the Hi- or Low frequency clock switches depending of the Prescaler1 multiplexer selection.

9.2.4 PRESCALER2 CLOCK SELECTION

The Prescaler2 input clock **Ck_Pr2** is derived from divided or undivided **Ck_Hi** or **Ck_Lo** input clock. Below table is an overview of the different prescaler1 clocking possibilities. The prescaler clock divider selection is done in register **RegClockCfg3** bits **SelCkPr2**.

SelCkPr2	Prescaler2 Clock
000	Ck_Hi (divided by 1)
001	Ck_Hi divided by 2
010	Ck_Hi divided by 4
011	Ck_Hi divided by 8
100	Ck_Lo (divided by 1)
Others 1xx	Ck_Lo (divided by 1)

The default Prescaler2 clock source after system reset (res_sys) shall be Ck_Lo divided by 1 (selection 0x4).

ReqCkHi or **ReqCkLo** signals are asserted to the Hi- or Low frequency clock switches depending of the Prescaler2 multiplexer selection.

9.3 CLOCK CONTROL

Ck_Hi and Ck_Lo are active only if needed.

- If **Ck_Hi** is selected by any of **SelCkCR**, **SelCkPr1**, **SelCkPr2**, its **ReqCkHi** signal becomes active and the oscillator as selected by the SelCkHi-multiplexer will be enabled, otherwise it shall be disabled. The oscillator is also enabled if forced by the corresponding FrcEn bit in register **RegClockCfg2**.
- If **Ck_Lo** is selected by any of **SelCkCR**, **SelCkPr1**, **SelCkPr2**, its **ReqCkLo** signal becomes active and the oscillator as selected by the SelCkLo-multiplexer will be enabled, otherwise it shall be disabled. The oscillator is also enabled if forced by the corresponding FrcEn bit in register **RegClockCfg2**.

As such the oscillators are only active if their output clock is needed for either **Ck_Hi** or **Ck_Lo**. Alternatively the user may always force-on any RC oscillator and one of the external clock sources (Xtal, resonator, PC4 ext clock)

Clock selection/request is provided as information which oscillator(s) are actually selected with its clock requested by a peripheral block. The request/selection bits **CkSwSelX**, **CkSwSelHi**, **CkSwSelLo** is high for the actual selected oscillator on the given clock switch. The coding is one-hot.

Clock status information is provided to show which oscillator(s) are actually active and outputting their clock on their clock switch. The status bits **CkSwStsX**, **CkSwStsHi**, **CkSwStsLo** is high for the actual active oscillator on the given clock switch. The coding is one-hot.

The clock selection and clock status signals are readable in register **RegCkSw1** and **RegCkSw2**. The coding is one-hot. A selected oscillator clock is only applied to the periphery if its selection and status bit match.

9.4 OSCILLATORS CONTROL

The oscillator control block assures that only the oscillators which are requested or which are forced-on are really active. The various status signals allow close monitoring of the clock switching and give essential information for power saving.

Figure 6; Oscillator control architecture

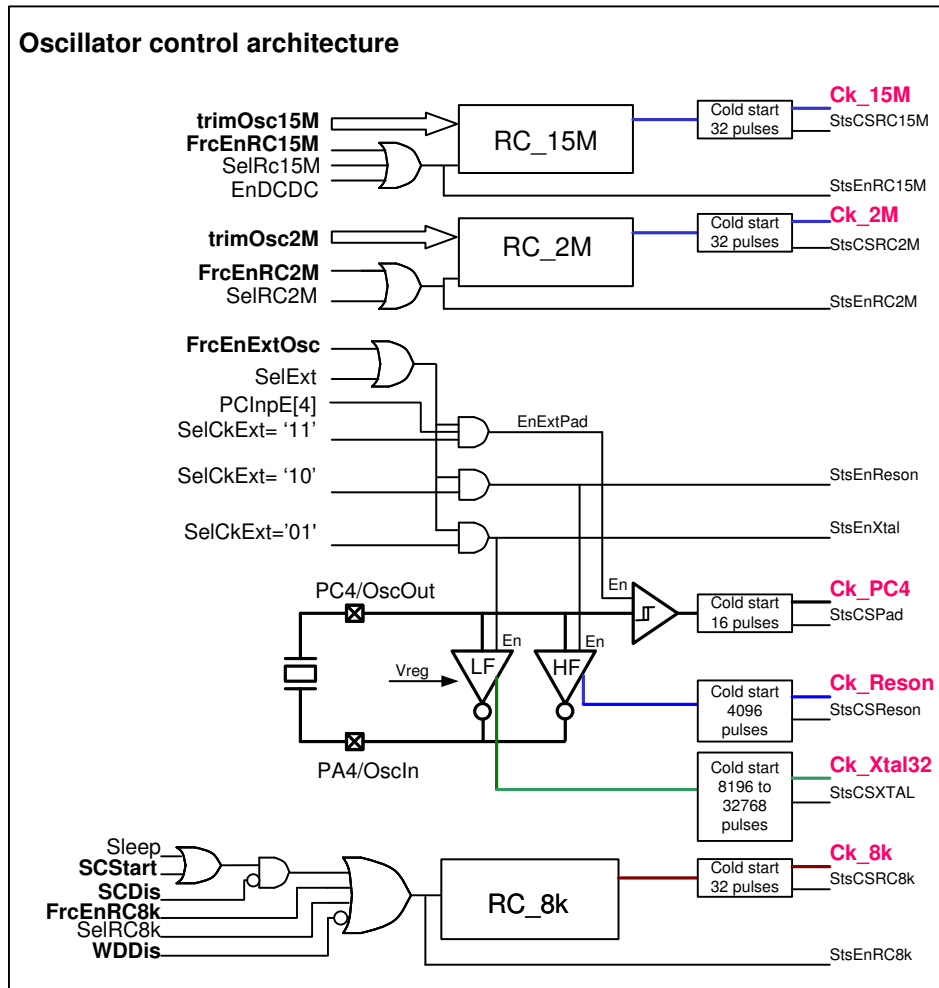

Oscillator availability is delayed by an individual oscillator ColdStart delay. Each disabled oscillator or external clock will go through the ColdStart phase when enabled.

Following delays apply:

Oscillator	ColdStart delay
RC 15 MHz	4 pulses
RC 2MHz	2 pulses
RC 8 kHz	32 pulses
Ext: from Pad	16 pulses
Ext: Resonator	4K pulses
Ext: Xtal	programmable by register bits XtalCldStart

The 32 KHz Xtal ColdStart delay is programmable by the register bits **XtalCldStart** as follows:

RegXtalCldStart	ColdStart delay
00	32K cycles (default)
01	24K cycles
10	16K cycles
11	8K cycles

The ColdStart functionality is blocking the given clock propagation to the circuit.

The status of ColdStart function for each oscillator shall be readable by the register **RegStsCStart** bits **StsCSReson**, **StsCSXtal**, **StsCSPad**, **StsCSRC8k**, **StsCSRC2M**, **StsCSRC15M**.

The oscillator Force-On functionality can be used to avoid recurrent coldstart delays on fast clock switching.

An Oscillator is enabled if its clock is requested by either of the **SelCkCR**, **SelCkPr1**, **SelCkPr2** clock selection bits or forced-on by register **RegClockCfg2** bits **FrcEnXXX** as follows:

Oscillator	Condition	Status bit
RC15 MHz	SelRC15M FrcEnRC15M	StsEnRC15M
RC2 MHz	SelRC2M FrcEnRC2M	StsEnRC2M
Xtal	(SelExt FrcEnExt) && SelCkExt="01"	StsEnXtal
Resonator	(SelExt FrcEnExt) && SelCkExt="10"	StsEnReson

The oscillator enable signals are readable by the register **RegStsEnOsc** bits **StsEnReson**, **StsEnXtal**, **StsEnRC8k**, **StsEnRC2M**, **StsEnRC15M**.

An External clock Source from pad PC4 is enabled if selected or forced-on by register **RegClockCfg2** bit **FrcEnExt** , its status is read on **StsCSPad**:

StsCSPad = (SelExt || **FrcEnExt**) && SelCkExt="11"
PCInpE[4] must be high to allow PC4 clock input

The oscillators (except RC_8K) and the external clock sources are automatically disabled in Sleep mode. This has priority over Select and Force-On functionality.

The oscillators and the external clock sources are automatically disabled by power-check functionality. This has priority over Select and Force-On functionality.

The RC 8 kHz oscillator is enabled

- in Sleep mode with active sleepcounter function
- if the watchdog is enabled,
- if requested by any of the **SelCkCR**, **SelCkPr1** and **SelCkPr2** clock selection
- and when forced-on.

The status bit of the RC_8k is readable in register **RegStsEnOsc** bit **StsEnRC8k**

StsEnRC8k = **FrcEnRC8k** || SelRC8k || ((Sleep || **SCStart**) && !**SCDis**) || !**WDDis**

Note:

The RC_8kHz oscillator can only be disabled at least 300us after its coldstart. (RegStsCStart.StsCSRC8k)

The settling time of the 2Mhz oscillator is approx 40us to be within 5% of the nominal frequency.

The settling time of the 15Mhz oscillator is approx 70us to be within 5% of the nominal frequency.

9.5 CLOCK CONTROL REGISTERS

0x0000		RegSysCfg1			System Configuration - 1
Bits	Name	Type	ResVal	ResSrc	Description
7	SelSleep	RW	0	ResSys	Select Sleep mode on Halt
6:5		NI	0		
4	EnBrownOut	RW	1	ResAna	Enable Brown Out
3:2	XtalCldStart	RW	'00'	ResSys	Select Xtal Osc. ColdStart length
1	StdByFastWkUp	RW	0	ResSys	Stand-by mode fast Wakeup
0		NI	0		

0x0003		RegClockCfg1			Clock Configuration - 1
Bits	Name	Type	ResVal	ResSrc	Description
7:6	SelCkExt	RW_Res	'00'	ResSys	Select External Component/Input clock source
5:4	SelCkHi	RW_Res	'01'	ResSys	Select High freq. Clock source
3:2	SelCkLo	RW_Res	'10'	ResSys	Select Low freq. Clock source
1	-	NI	-	-	Not implemented
0	FrcFastRead	RW	0	ResSys	Force NVM Fast Read

0x0004		RegClockCfg2			Clock Configuration - 2
Bits	Name	Type	ResVal	ResSrc	Description
7	FrcEnRC15M	RW	0	ResSys	Force 15 MHz RC Oscillator ON
6	FrcEnRC2M	RW	0	ResSys	Force 2 MHz RC Oscillator ON
5	FrcEnRC8k	RW	0	ResSys	Force 8 kHz RC Oscillator ON
4	FrcEnExt	RW	0	ResSys	Force selected (SelCkExt) External Component/Input clock source ON
3:0	SelCkCR	RW_Res	0x3	ResSys	Select CoolRisc/CPU Clock source

0x0005		RegClockCfg3			Clock Configuration - 3
Bits	Name	Type	ResVal	ResSrc	Description
7:5	SelCkPr1	RW_Res	'011'	ResSys	Select Prescaler1 Clock source
4:2	SelCkPr2	RW_Res	'100'	ResSys	Select Prescaler2 Clock source
1:0	-	NI	-	-	-

0x02A5		RegStsCStart			Oscillators ColdStart Status
Bits	Name	Type	ResVal	ResSrc	Description
7:6	-	NI	-	-	-
5	StsCSRReson	RO	1	ResSys	ColdStart Status of (4 MHz) Resonator Oscillator
4	StsCSXtal	RO	1	ResSys	ColdStart Status of (32K Hz) Xtal Oscillator
3	StsCSPad	RO	1	ResSys	ColdStart Status of External Pad-Clock
2	StsCSRC8k	RO	0	ResSys	ColdStart Status of 8 kHz RC Oscillator
1	StsCSRC2M	RO	0	ResSys	ColdStart Status of 2 MHz RC Oscillator
0	StsCSRC15M	RO	1	ResSys	ColdStart Status of 15 MHz RC Oscillator

0x02A6		RegStsEnOsc			Oscillators Enable Status
Bits	Name	Type	ResVal	ResSrc	Description
7:5	-	NI	-	-	Not implemented
4	StsEnReson	RO	0	ResSys	Enabled Status/State of (4 MHz) Resonator Oscillator
3	StsEnXtal	RO	0	ResSys	Enabled Status/State of (32K Hz) Xtal Oscillator
2	StsEnRC8k	RO	1	ResSys	Enabled Status/State of 8 kHz RC Oscillator
1	StsEnRC2M	RO	1	ResSys	Enabled Status/State of 2 MHz RC Oscillator
0	StsEnRC15M	RO	0	ResSys	Enabled Status/State of 15 MHz RC Oscillator



0x02A7		RegCkSw1			Clock switches Selector/Request and current Status - 1
Bits	Name	Type	ResVal	ResSrc	Description
7	CkSwSelX	RO	0	ResSys	Ck_SW Clock (Ck-Hi/Ck-Lo) Sync. clock switch Selector/Request Status '1' - CK_Lo, '0' - CK_Hi
6	CkSwStsX	RO	0	ResSys	Ck_SW Clock (Ck-Hi/Ck-Lo) Sync. clock switch current Status '1' - CK_Lo, '0' - CK_Hi
5:3	CkSwSelHi	RO	'010'	ResSys	Ck-Hi Clock switch (one-hot) Selector/Request Status bit0 – Ck_15M, Bit1 – Ck_2M, bit2 – Ck_Ext
2:0	CkSwStsHi	RO	'010'	ResSys	Ck-Hi Clock switch (one-hot) current Status bit0 – Ck_15M, Bit1 – Ck_2M, bit2 – Ck_Ext

0x02A8		RegCkSw2			Clock switches Selector/Request and current Status - 2
Bits	Name	Type	ResVal	ResSrc	Description
7:6	-	NI	-	-	Not implemented
5:3	CkSwSelLo	RO	'100'	ResSys	Ck-Lo Clock switch (one-hot) Selector/Request Status bit0 – Ck_Ext, Bit1 – Ck_Ext/4, bit2 – Ck_8k
2:0	CkSwStsLo	RO	'100'	ResSys	Ck-Lo Clock switch (one-hot) current Status bit0 – Ck_Ext, Bit1 – Ck_Ext/4, bit2 – Ck_8k

10. PRESCALER1

The prescaler1 is a 15 stage clock divider. It is typically used to deliver the input clocks to the digital peripherals (timers, SPI, etc..). Its last stage output is on 1Hz (at 32768Hz input clock) and therefore most often used to construct a RTC (Real Time Clock) system.

It can also be used as a free running counter by reading the current status of *Pr1Ck0*(MSB) to *Pr1Ck7*(LSB) in register **RegPresc1Val**.

10.1 PRESCALER1 CLOCK SELECTION

The Prescaler1 input clock *Ck_Pr1* is derived from divided or undivided *Ck_Hi* or *Ck_Lo* input clock. Below table is an overview of the different prescaler1 clocking possibilities. The prescaler clock divider selection is done in register **RegClockCfg3** bits **SelCkPr1**.

SelCkPr1	Prescaler1 Clock
000	<i>Ck_Hi</i> (divided by 1)
001	<i>Ck_Hi</i> divided by 2
010	<i>Ck_Hi</i> divided by 4
011	<i>Ck_Hi</i> divided by 8 (default)
100	<i>Ck_Lo</i> (divided by 1)
Others	<i>Ck_Hi</i> divided by 8

The default Prescaler1 clock source after system reset (**ResSys**) shall be *Ck_Hi* divided by 8 (selection 0x3).

It is possible to run the 15 stage prescaler1 on 13 stages only. This is typically used when connecting the RC_8K oscillator as the prescaler1 clock source and allow to keep the nominal prescaler output frequencies as if there would be an 32kHz Xtal oscillator connected (prescaler at 15 stages). The prescaler1 length selection is done in register **RegPrescCfg** bit **Presc1Len** ('0'= 15 stages, '1'=13 stages).

The Signals *Pr1Ck14* and *Pr1Ck13* are thus not influenced by the shortening.

Assuming a Prescaler1 with N stages, then the signal *Pr1Ck[N]* is the input of the first stage, *Pr1Ck[N-1]* is the output of the first stage (input divided by 2) and *Pr1Ck0* is the output of the last stage (the lowest frequency). This leads to following clock source name definitions.

Prescaler1 stage	Clock Name	Presc1Len = '0'			Presc1Len = '1'		
		Division by	Fout		Division by	Fout	
Prescaler source:	<i>Pr1Ck15</i>	1	2 ⁰	32K	1	2 ⁰	8K
Stage 1	<i>Pr1Ck14</i>	2	2 ¹	16K	2	2 ¹	4K
Stage 2	<i>Pr1Ck13</i>	4	2 ²	8K	4	2 ²	2K
Stage 3	<i>Pr1Ck12</i>	8	2 ³	4K	2	2 ¹	4K
Stage 4	<i>Pr1Ck11</i>	16	2 ⁴	2K	4	2 ²	2K
Stage 5	<i>Pr1Ck10</i>	32	2 ⁵	1K	8	2 ³	1K
Stage 6	<i>Pr1Ck9</i>	64	2 ⁶	512	16	2 ⁴	512
Stage 7	<i>Pr1Ck8</i>	128	2 ⁷	256	32	2 ⁵	256
Stage 8	<i>Pr1Ck7</i>	256	2 ⁸	128	64	2 ⁶	128
Stage 9	<i>Pr1Ck6</i>	512	2 ⁹	64	128	2 ⁷	64
Stage 10	<i>Pr1Ck5</i>	1K	2 ¹⁰	32	256	2 ⁸	32
Stage 11	<i>Pr1Ck4</i>	2K	2 ¹¹	16	512	2 ⁹	16
Stage 12	<i>Pr1Ck3</i>	4K	2 ¹²	8	1K	2 ¹⁰	8
Stage 13	<i>Pr1Ck2</i>	8K	2 ¹³	4	2K	2 ¹¹	4
Stage 14	<i>Pr1Ck1</i>	16K	2 ¹⁴	2	4K	2 ¹²	2
Stage 15	<i>Pr1Ck0</i>	32K	2 ¹⁵	1	8K	2 ¹³	1

The frequencies Fout given in this table are based on 32 KHz clock selection as a prescaler1 input source.

10.2 PRESCALER1 RESET

Writing '1' to the bit **Presc1Clr** in register **RegPrescCfg** sets all stages to '1' and counting restarts.

10.2.1.1 PRESCALER1 INTERRUPT GENERATION

The prescaler1 generates 2 interrupt signals

- **IntPr1Ck0** interrupt signal is generated on the stage 15 overrun (rising **Pr1Ck0** edge)
- **IntPr1Ck5/3** interrupt signal is generated on the stage 10 or stage12 overrun (rising **Pr1Ck3** or **Pr1Ck5** edge).

The selection is done in register **PrescCfg** bit **Presc1SelIntck5/3** as follows:

Presc1SelIntck5/3	Int. Freq. (based on 32KHz)	Pr1-Ck
0 (Default)	8 Hz	Pr1Ck3
1	32 Hz	Pr1Ck5

The frequencies given in this table are based on 32 KHz clock selection as a prescaler1 input source.

10.3 PRESCALER REGISTERS

0x0007		RegPrescCfg			Prescaler-1/2 Configuration
Bits	Name	Type	ResVal	ResSrc	Description
7	Presc1Clr	OS	0		Prescaler-1 Clear counter
6	Presc1Len	RW	0	ResSys	Prescaler-1 Length
5	Presc1SelIntck5/3	RW	0	ResSys	Select Prescaler-1 irq-B source: 0-8Hz, 1-32Hz
4	Presc2Clr	OS	0		Prescaler-2 Clear counter
3:0	-	NI	-	-	Not implemented

0x0008		RegPresc1Val			Prescaler-1 Value (MSB)
Bits	Name	Type	ResVal	ResSrc	Description
7:0	Presc1Val	RO	0xFF	ResSys	Prescaler-1 Value (MSB) , Pr1Ck0 to Pr1Ck7 status

11. PRESCALER2

The prescaler2 is a 10 stage clock divider. It is typically used to deliver the input clocks to the digital peripherals (timers, SPI, etc. It can also be used as a free running counter by reading the current status of **Pr2Ck0**(MSB) to **Pr2Ck7**(LSB) in register **RegPresc2Val**.

11.1 PRESCALER2 CLOCK SELECTION

The Prescaler2 input clock **Ck_Pr2** is derived from divided or undivided **Ck_Hi** or **Ck_Lo** input clock. Below table is an overview of the different prescaler1 clocking possibilities. The prescaler clock divider selection is done in register **RegClockCfg3** bits **SelCkPr2**.

SelCkPr2	Prescaler2 Clock
000	Ck_Hi (divided by 1)
001	Ck_Hi divided by 2
010	Ck_Hi divided by 4
011	Ck_Hi divided by 8
100	Ck_Lo (divided by 1)
Others	Ck_Lo (divided by 1)

The default Prescaler-2 clock source after system reset (res_sys) shall be **Ck_Lo** divided by 1 (selection 0x4).

Assuming a Prescaler2 with N stages, then the signal **Pr2ck[N]** is the input of the first stage, **Pr2Ck[N-1]** is the output of the first stage (input divided by 2) and **Pr2Ck0** is the output of the last stage (the lowest frequency). This leads to following clock source name definitions.

Prescaler2 stage	Clock Name	Division by		Fout
Prescaler source:	Pr2Ck10	1	2 ⁰	2 M
Stage 1	Pr2Ck9	2	2 ¹	1 M
Stage 2	Pr2Ck8	4	2 ²	500 k
Stage 3	Pr2Ck7	8	2 ³	250 k
Stage 4	Pr2Ck6	16	2 ⁴	125 k
Stage 5	Pr2Ck5	32	2 ⁵	62500
Stage 6	Pr2Ck4	64	2 ⁶	31250
Stage 7	Pr2Ck3	128	2 ⁷	15625
Stage 8	Pr2Ck2	256	2 ⁸	7812.5
Stage 9	Pr2Ck1	512	2 ⁹	3906.25
Stage 10	Pr2Ck0	1K	2 ¹⁰	1953.125

The frequencies Fout given in this table are based on 32 KHz clock selection as a prescaler2 input source.

11.2 PRESCALER2 RESET

Writing '1' to the bit **Presc2Clr** in register **RegPrescCfg** sets all stages to '1' and counting restarts.

11.3 PRESCALER2 REGISTERS

0x0007		RegPrescCfg			Prescaler-1/2 Configuration
Bits	Name	Type	ResVal	ResSrc	Description
7	Presc1Clr	OS	0		Prescaler-1 Clear counter
6	Presc1Len	RW	0	ResSys	Prescaler-1 Length
5	Presc1SelIntck5/3	RW	0	ResSys	Select Prescaler-1 irq-B source: 0-8Hz, 1-32Hz
4	Presc2Clr	OS	0		Prescaler-2 Clear counter
3:0	-	NI	-	-	Not implemented

0x0009		RegPresc2Val			Prescaler-2 Value (MSB)
Bits	Name	Type	ResVal	ResSrc	Description
7:0	Presc2Val	RO	0xFF	ResSys	Prescaler-2 Value (MSB), Pr2Ck0 to Pr2Ck7 status

12. INTERRUPT AND EVENT CONTROLLER

12.1 INTERRUPTS GENERAL

12.1.1 BASIC FEATURES

The circuit handles 24 independent Interrupt sources grouped into 3 priority levels.

- Highest Priority : Level 0 : Prescaler1, PmMiss, GASP, ADC, Timer, Ports
- Medium Priority : Level 1 : SPI, Prescaler1, OpAmp, Timer, Ports
- Lowest Priority : Level 2 : Timer, Ports, Sleep counter, VLD

As such the circuit contains

- 13 external Interrupts (Ports, SPI, OpAmp, VLD, GASP)
- 12 internal Interrupts (Prescaler, DoC, Timer, SPI, PmMiss, Sleep Counter)

Interrupt from SPI and Timer may be initialized by either external or internal actions (i.e. timer running on external clock)

Interrupts force a CALL to a fixed interrupt vector, save the program counter (PC) onto the hardware stack and reset the general interrupt bit (**GIE**). If the CPU was in StandBy mode prior to Interrupt then it will come back in active mode. Each priority level has its own interrupt vector.

- Level 1 → sets bit **IN1** in CoolRISC status register → Program memory address 1 → Call Vector 1
- Level 2 → sets bit **IN2** in CoolRISC status register → Program memory address 2 → Call Vector 2
- Level 0 → sets bit **INO** in CoolRISC status register → Program memory address 3 → Call Vector 0

The **GIE** bit is restored when returning from interrupt with the RETI instruction. The RET instruction does not reinstall the GIE. Nested interrupts are possible by re-enabling the GIE bit within the interrupt routine.

Functions such as interrupt Pre- or Post-masking, enabling and clearing are available on different levels in the interrupt structure. At power up or after any reset all interrupt inputs are masked and the GIE is cleared.

The Interrupt handling is split into 2 parts.

- One part deals with the acquisition, masking and clearing of the interrupts outside of the CPU.
→ Interrupt acquisition, IRQ Controller
- The 2nd part covers all aspects of priority and interrupts enabling inside the CoolRISC core.
→ CPU interrupts handling

Figure 7, Interrupt top level diagram

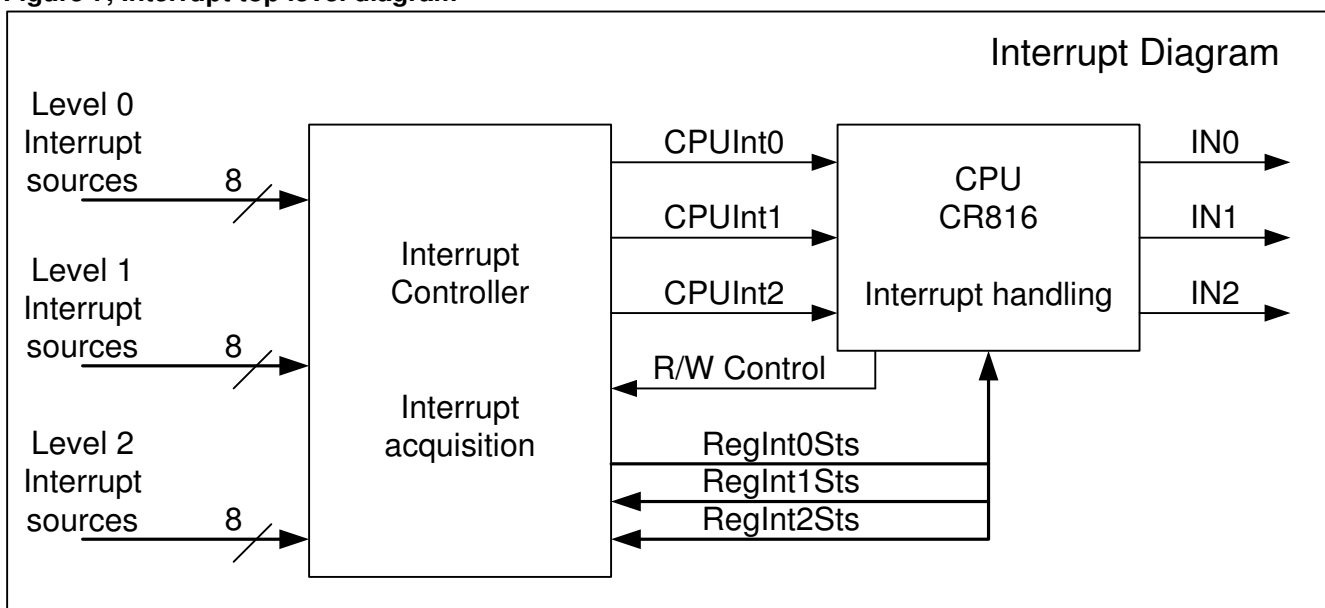

12.2 INTERRUPT ACQUISITION

A positive edge on any of the unmasked interrupt source signals will set the corresponding interrupt register bit and activate the mapped CPU interrupt input. (I.e. Timer3 interrupt **IntTim3** will set bit **Int1StsTim3** in register **RegInt1Sts** and activate the CPUInt1 interrupt input if mask bit **Int1MskTim3** is '1' [non-masked]).

The 3 priority branches for interrupt acquisition are totally independent of each other, masking and selective clear of interrupts on one interrupt vector input does not modify the others.

All Interrupts inputs are available in active and standby mode.

Table 1. Interrupts signal sources and destination

Interrupt sources	Int vector	Mapping	remark	Sleep wake-up
IntPort0	0	Int0StsPort0	PA0 or PC0, positive and/or negative edge	X (PA)
IntTim1		Int0StsTim1	Timer1 Input capture, Compare value, Compare Full	
IntPr1Ck0		Int0StsPrCk0	Prescaler1 1Hz (Pr1Ck0)	
IntADC		Int0StsADC	ADC conversion finished	
IntDoCDM		Int0StsDoCDM	DoC data memory address match	
IntDoCPM		Int0StsDoCPM	DoC program memory address match	
IntGASP		Int0StsGASP	GASP data reception with sign='1'	X
IntPmMiss		Int0StsPmMiss	Program memory, wait introduction	
IntPort2		1	Int1StsPort2	PA2 or PC2, positive and/or negative edge
IntPort1	Int1StsPort2		PA1 or PC1, positive and/or negative edge	X (PA)
IntTim2	Int1StsTim2		Timer2, Input capture, Compare value, Compare Full	
IntTim3	Int1StsTim3		Timer3, Input capture, Compare value, Compare Full	
IntOpAmp	Int1StsOpAmp		Comparator; falling and/or rising output change	X
IntPr1Ck5/3	Int1StsPr1Ck5/3		Prescaler 1, 8Hz or 32Hz (falling edge)	
IntSPISStop	Int1StsSPISStop		SPI, Stop transmission 1 byte	
IntSPISStart	Int1StsSPISStart		SPI, Start transmission 1byte	
IntVLD	2		Int2StsVLD	Voltage level detector; input low
IntSlpCnt		Int2StsSlpCnt	Sleep counter wakeup timeout	X
IntPort7		Int2StsPort7	PA7 or PC7, positive and/or negative edge	X (PA)
IntPort6		Int2StsPort6	PA6 or PC6, positive and/or negative edge	X (PA)
IntPort5		Int2StsPort5	PA5 or PC5, positive and/or negative edge	X (PA)
IntPort4		Int2StsPort4	PA4 or PC4, positive and/or negative edge	X (PA)
IntPort3		Int2StsPort3	PA3 or PC3, positive and/or negative edge	X (PA)
IntTim4		Int2StsTim4	Timer4, Input capture, Compare value, Compare Full	

The following interrupt sources can wake-up the device from the Sleep mode if enabled by appropriate interrupt masks:

Table 2. Wake-Up Interrupts

Interrupt Source	Interrupt Status
PortA; regardless of RegIntPortSrc	IntXStsPort7 to IntXStsPort0
Sleep counter	Int2StsSlpCnt
SVLD	Int2StsVLD
OpAmp	Int1StsOpAmp
GASP	Int0StsGASP

Direct (non-debounced) port A interrupts are, used for the wake-up, totally independent of the debouncer settings.

12.3 INTERRUPTS FROM IO PORTS

The register **RegIntPortSrc** selects the port interrupt source **IntPort** coming from port A or port C in Active and StandBy modes. In Sleep mode, the port A is always selected independent of **RegIntPortSrc** settings.

- If **RegIntPortSrc[X] = '0'** then **IntPort[X]** source shall be **IntPA[X]** otherwise it is **IntPC[X]**.
- The default value of **RegIntPortSrc** is 0x00, i.e. **IntPA[X]** is selected.

12.4 INTERRUPT ACQUISITION MASKING.

At start up or after any reset all interrupt sources are masked (mask bits are '0'). To activate a specific interrupt source input the corresponding mask bit must be set '1'. Masking does not clear an existing interrupt but will prevent future interrupts on the same input. Refer to Figure 8, Interrupt acquisition architecture.

12.4.1 PRE AND POSTMASKING OF INTERRUPTS

One pair of registers for each level of priority **RegIntXMsk** and **RegIntXPostMsk** control the interrupt generation for CPU and catch an incoming request into the status registers **RegIntXSts** as follows:

- If **RegIntXMsk[Y] = '1'** then the appropriate CPU interrupt line **IntX** is asserted and interrupt is caught in the status register **RegIntXSts[Y]**.
- If **RegIntXMsk[Y] = '0'** then the appropriate CPU interrupt line **IntX** is NOT asserted. The interrupt request is caught in the status register **RegIntXSts[Y]** only if **RegIntXPostMsk[Y] = '1'**.
- If **RegIntXMsk[Y] = '0'** then the appropriate CPU interrupt line **IntX** is NOT asserted. The interrupt request is NOT caught in the status register **RegIntXSts[Y]** if **RegIntXPostMsk[Y] = '0'**.

Figure 8, Interrupt acquisition architecture

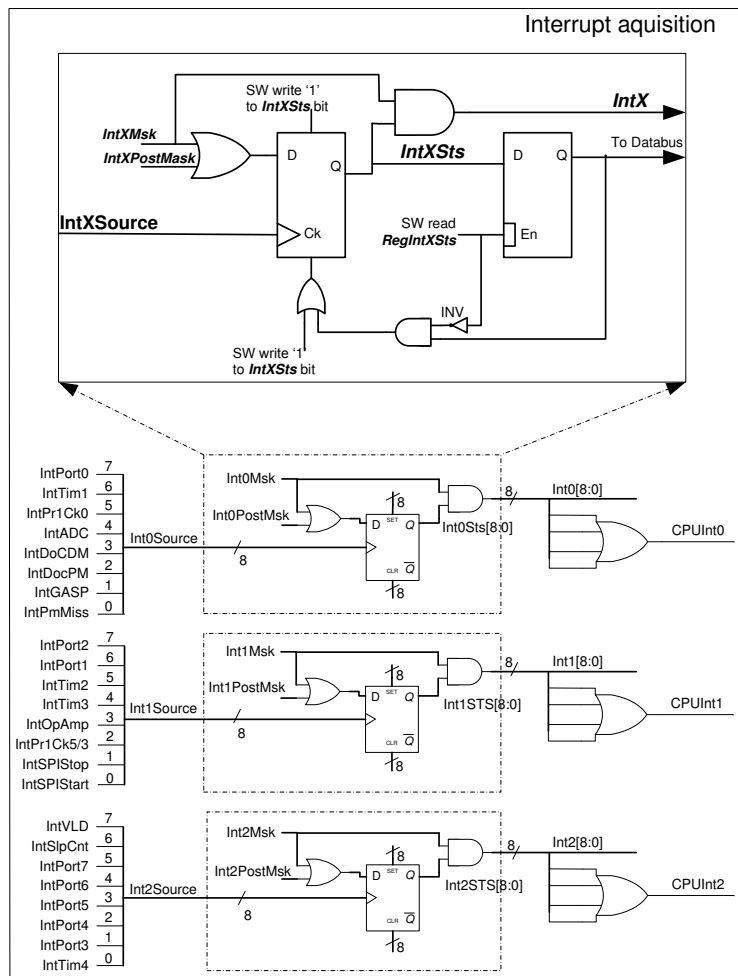

12.5 INTERRUPT ACQUISITION CLEARING

A pending interrupt can be cleared in 3 ways

- Reading the interrupt registers **RegInt0Sts**, **RegInt1Sts** and **RegInt2Sts** will automatically clear all stored interrupts which were set prior to the read in the corresponding register. This read is normally done inside the interrupt subroutine to determine the source of the interrupt.
- Each interrupt request status bit can be individually cleared (set '0') by writing '0' to the corresponding **RegInt0Sts**, **RegInt1Sts** and **RegInt2Sts** register bit. Software clearing of the interrupt status bit has priority over an incoming interrupt.
- At power up or after any reset all interrupt registers are reset.

12.5.1 SOFTWARE INTERRUPT ACQUISITION SET

Each interrupt request status bit can be individually set (set '1') by writing '1' to the corresponding **RegInt0Sts**, **RegInt1Sts** and **RegInt2Sts** register bit. Write '1' has the highest priority on the status bit.

12.6 INTERRUPT REGISTERS

0x0061		RegInt0Sts			Interrupt level-0 Status
Bits	Name	Type	ResVal	ResSrc	Description
7	Int0StsPort(0)	RW-INT	0	ResSys	Interrupt level-0 Status - Port(0)
6	Int0StsTim1	RW-INT	0	ResSys	Interrupt level-0 Status - Timer-1
5	Int0StsPr1Ck0	RW-INT	0	ResSys	Interrupt level-0 Status - Prescaler1 Ck0 (1Hz)
4	Int0StsADC	RW-INT	0	ResSys	Interrupt level-0 Status - ADC
3	Int0StsDoCDM	RW-INT	0	ResSys	Interrupt level-0 Status - DoC DM
2	Int0StsDoCPM	RW-INT	0	ResSys	Interrupt level-0 Status - DoC PM
1	Int0StsGASP	RW-INT	0	ResSys	Interrupt level-0 Status - GASP
0	Int0StsPmMiss	RW-INT	0	ResSys	Interrupt level-0 Status - PM_Miss

0x0062		RegInt1Sts			Interrupt level-1 Status
Bits	Name	Type	ResVal	ResSrc	Description
7	Int1StsPort(2)	RW-INT	0	ResSys	Interrupt level-1 Status - Port(2)
6	Int1StsPort(1)	RW-INT	0	ResSys	Interrupt level-1 Status - Port(1)
5	Int1StsTim2	RW-INT	0	ResSys	Interrupt level-1 Status - Timer-2
4	Int1StsTim3	RW-INT	0	ResSys	Interrupt level-1 Status - Timer-3
3	Int1StsOpAmp	RW-INT	0	ResSys	Interrupt level-1 Status - OpAmp
2	Int1StsPr1Ck5/3	RW-INT	0	ResSys	Interrupt level-1 Status – Prescaler1 Ck5 or Ck3
1	Int1StsSPIStop	RW-INT	0	ResSys	Interrupt level-1 Status - SPI_Stop
0	Int1StsSPIStart	RW-INT	0	ResSys	Interrupt level-1 Status - SPI_Start

0x0063		RegInt2Sts			Interrupt level-2 Status
Bits	Name	Type	ResVal	ResSrc	Description
7	Int2StsVLD	RW-INT	0	ResSys	Interrupt level-2 Status - VLD
6	Int2StsSlpCnt	RW-INT	0	ResSys	Interrupt level-2 Status - Sleep Counter
5	Int2StsPort(7)	RW-INT	0	ResSys	Interrupt level-2 Status - Port(7)
4	Int2StsPort(6)	RW-INT	0	ResSys	Interrupt level-2 Status - Port(6)
3	Int2StsPort(5)	RW-INT	0	ResSys	Interrupt level-2 Status - Port(5)
2	Int2StsPort(4)	RW-INT	0	ResSys	Interrupt level-2 Status - Port(4)
1	Int2StsPort(3)	RW-INT	0	ResSys	Interrupt level-2 Status - Port(3)
0	Int2StsTim4	RW-INT	0	ResSys	Interrupt level-2 Status - Timer-4

0x0064		RegInt0Msk			Interrupt level-0 Mask
Bits	Name	Type	ResVal	ResSrc	Description
7	Int0MskPort(0)	RW	0	ResSys	Interrupt level-0 Mask - Port(0)
6	Int0MskTim1	RW	0	ResSys	Interrupt level-0 Mask - Timer-1
5	Int0MskPr1Ck0	RW	0	ResSys	Interrupt level-0 Mask - Prescaler1 1Hz
4	Int0MskADC	RW	0	ResSys	Interrupt level-0 Mask - ADC
3	Int0MskDoCDM	RW	0	ResSys	Interrupt level-0 Mask - DoC DM
2	Int0MskDoCPM	RW	0	ResSys	Interrupt level-0 Mask - DoC PM
1	Int0MskGASP	RW	0	ResSys	Interrupt level-0 Mask - GASP
0	Int0MskPmMiss	RW	0	ResSys	Interrupt level-0 Mask - PM_Miss

0x0065		RegInt1Msk			Interrupt level-1 Mask
Bits	Name	Type	ResVal	ResSrc	Description
7	Int1MskPort(2)	RW	0	ResSys	Interrupt level-1 Mask - Port(2)
6	Int1MskPort(1)	RW	0	ResSys	Interrupt level-1 Mask - Port(1)
5	Int1MskTim2	RW	0	ResSys	Interrupt level-1 Mask - Timer-2
4	Int1MskTim3	RW	0	ResSys	Interrupt level-1 Mask - Timer-3
3	Int1MskOpAmp	RW	0	ResSys	Interrupt level-1 Mask - OpAmp
2	Int1MskPr1Ck5/3	RW	0	ResSys	Interrupt level-1 Mask - Prescaler1 Ck5 or Ck3
1	Int1MskSPIStop	RW	0	ResSys	Interrupt level-1 Mask - SPI_Stop
0	Int1MskSPIStart	RW	0	ResSys	Interrupt level-1 Mask - SPI_Start

0x0066		RegInt2Msk			Interrupt level-2 Mask
Bits	Name	Type	ResVal	ResSrc	Description
7	Int2MskVLD	RW	0	ResSys	Interrupt level-2 Mask - VLD
6	Int2MskSlpCnt	RW	0	ResSys	Interrupt level-2 Mask - Sleep Counter
5	Int2MskPort(7)	RW	0	ResSys	Interrupt level-2 Mask - Port(7)
4	Int2MskPort(6)	RW	0	ResSys	Interrupt level-2 Mask - Port(6)
3	Int2MskPort(5)	RW	0	ResSys	Interrupt level-2 Mask - Port(5)
2	Int2MskPort(4)	RW	0	ResSys	Interrupt level-2 Mask - Port(4)
1	Int2MskPort(3)	RW	0	ResSys	Interrupt level-2 Mask - Port(3)
0	Int2MskTim4	RW	0	ResSys	Interrupt level-2 Mask - Timer-4

0x0067		RegInt0PostMsk			Interrupt level-0 Post_Mask
Bits	Name	Type	ResVal	ResSrc	Description
7	Int0PostMskPort(0)	RW	0	ResSys	Interrupt level-0 Post_Mask - Port(0)
6	Int0PostMskTim1	RW	0	ResSys	Interrupt level-0 Post_Mask - Timer-1
5	Int0PostMskPr1Ck0	RW	0	ResSys	Interrupt level-0 Post_Mask - Prescaler1 1Hz
4	Int0PostMskADC	RW	0	ResSys	Interrupt level-0 Post_Mask - ADC
3	Int0PostMskDoCDM	RW	0	ResSys	Interrupt level-0 Post_Mask - DoC DM
2	Int0PostMskDoCPM	RW	0	ResSys	Interrupt level-0 Post_Mask - DoC PM
1	Int0PostMskGASP	RW	0	ResSys	Interrupt level-0 Post_Mask - GASP
0	Int0PostMskPmMiss	RW	0	ResSys	Interrupt level-0 Post_Mask - PM_Miss

0x0068		RegInt1PostMsk			Interrupt level-1 Post_Mask
Bits	Name	Type	ResVal	ResSrc	Description
7	Int1PostMskPort(2)	RW	0	ResSys	Interrupt level-1 Post_Mask - Port(2)
6	Int1PostMskPort(1)	RW	0	ResSys	Interrupt level-1 Post_Mask - Port(1)
5	Int1PostMskTim2	RW	0	ResSys	Interrupt level-1 Post_Mask - Timer-2
4	Int1PostMskTim3	RW	0	ResSys	Interrupt level-1 Post_Mask - Timer-3
3	Int1PostMskOpAmp	RW	0	ResSys	Interrupt level-1 Post_Mask - OpAmp
2	Int1PostMskPr1Ck5/3	RW	0	ResSys	Interrupt level-1 Post_Mask - Prescaler1 Ck5 or Ck3
1	Int1PostMskSPIStop	RW	0	ResSys	Interrupt level-1 Post_Mask - SPI_Stop
0	Int1PostMskSPIStart	RW	0	ResSys	Interrupt level-1 Post_Mask - SPI_Start



0x0069		RegInt2PostMsk			Interrupt level-2 Post_Mask
Bits	Name	Type	ResVal	ResSrc	Description
7	Int2PostMskVLD	RW	0	ResSys	Interrupt level-2 Post_Mask - VLD
6	Int2PostMskSlpCnt	RW	0	ResSys	Interrupt level-2 Post_Mask - Sleep Counter
5	Int2PostMskPort(7)	RW	0	ResSys	Interrupt level-2 Post_Mask - Port(7)
4	Int2PostMskPort(6)	RW	0	ResSys	Interrupt level-2 Post_Mask - Port(6)
3	Int2PostMskPort(5)	RW	0	ResSys	Interrupt level-2 Post_Mask - Port(5)
2	Int2PostMskPort(4)	RW	0	ResSys	Interrupt level-2 Post_Mask - Port(4)
1	Int2PostMskPort(3)	RW	0	ResSys	Interrupt level-2 Post_Mask - Port(3)
0	Int2PostMskTim4	RW	0	ResSys	Interrupt level-2 Post_Mask - Timer-4

0x006A		RegIntPortSrc			Port Interrupt source selector: 0-PortA, 1-PortC
Bits	Name	Type	ResVal	ResSrc	Description
7:0	IntPortSrc	RW	0x00	ResSys	Port Interrupt source selector: 0-PortA, 1-PortC

12.7 EVENT GENERAL

12.7.1 BASIC FEATURES

Events are most commonly used to restart the processor from the StandBy mode without jumping to the interrupt vector. Events can also be combined with the JEV instruction (Jump on Event) or been used for wake-up from Sleep mode.

The circuit handles 4 independent event sources grouped into 2 event sources, both of same priority

- Bank 0 Source : EV0: GASP
- Bank 1 Source : EV1: ADC, SPI, Sleep Counter

Figure 9, Event top level diagram

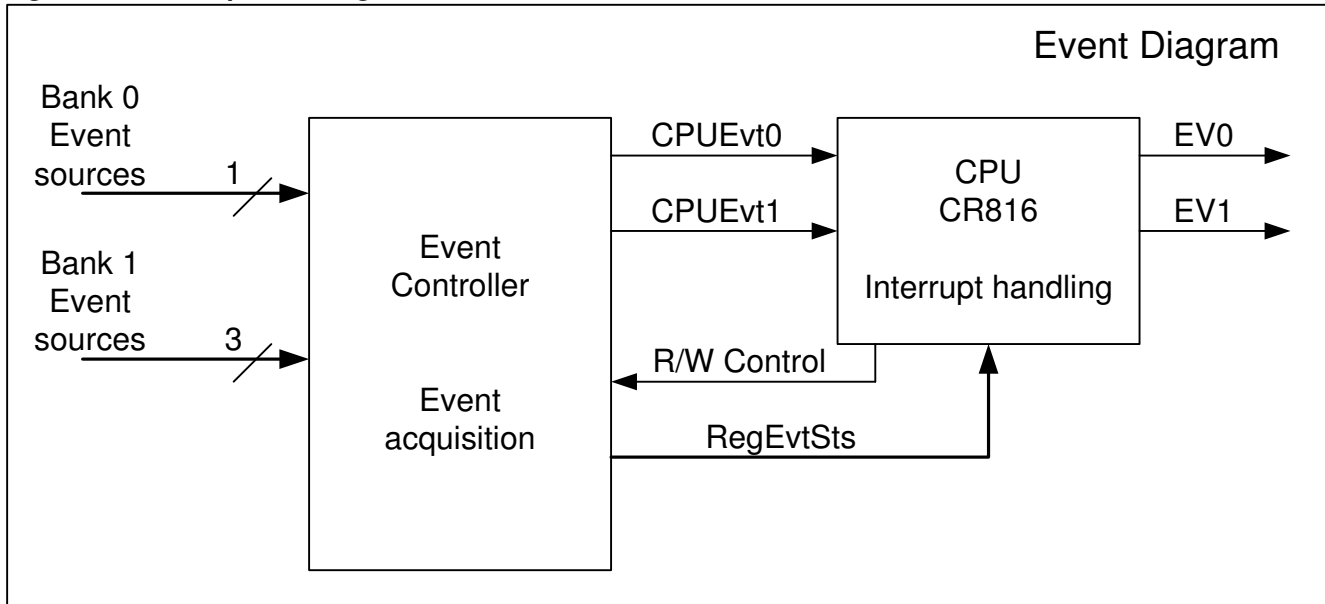

12.8 EVENT ACQUISITION

A positive edge on any of the unmasked event source signals will set the corresponding event status bit and activate the mapped CPU event input. (I.e. ADC event **EvtADC** will set bit **Evt1StsADC** in register **RegEvtSts** and activate the CPUEvt1 event input if mask bit **Evt1MskADC** is '1' [non-masked]).

The 2 branches for event acquisition are totally independent of each other, masking and selective clear of events on one event status input does not modify the others.

Table 3. Event signal sources and destination

Event sources	Event bank	Mapping	remark	Sleep wake-up
EvtGASP	0	Evt0StsGASP	GASP data reception	X
EvtSlpCnt	1	Evt1StsSlpCnt	Sleep counter wakeup timeout	X
EvtSPI		Evt1StsSPI	SPI, Start or Stop transmission	
EvtADC		Evt1StsADC	ADC conversion finished	

The following event sources shall wake-up the device from the Sleep mode if enabled by appropriate event masks:

Table 4. Wake-Up Events

Event Source	Event Status
Sleep counter	Evt1StsSlpCnt
GASP	Evt0StsGASP

12.9 EVENT MASKING

At start up or after any reset all event sources are masked (mask bits are '0'). To activate a specific event source input the corresponding mask bit must be set '1'. Masking does not clear an existing event but will prevent future events on the same input. Refer to Figure 10, Event acquisition architecture.

12.9.1.1 PRE AND POSTMASKING OF EVENTS

One pair of registers bits for each event **EvtXMsk** and **EvtXPostMsk** in register **RegEvtCfg** control the event generation for CPU and catch an incoming request into the status registers **RegEvtSts** as follows:

- If **EvtXMsk='1'** then the appropriate CPU event line **EVX** is asserted and the event is caught in the status bit **EvtXSts**.
- If **EvtXMsk='0'** then the appropriate CPU interrupt line **EVX** is NOT asserted. The event is caught in the status register **EvtXSts** only if **EvtXPostMsk='1'**.
- If **EvtXMsk='0'** then the appropriate CPU interrupt line **EVX** is NOT asserted. The event is NOT caught in the status register **EvtXSts** only if **EvtXPostMsk='0'**.

Figure 10, Event acquisition architecture

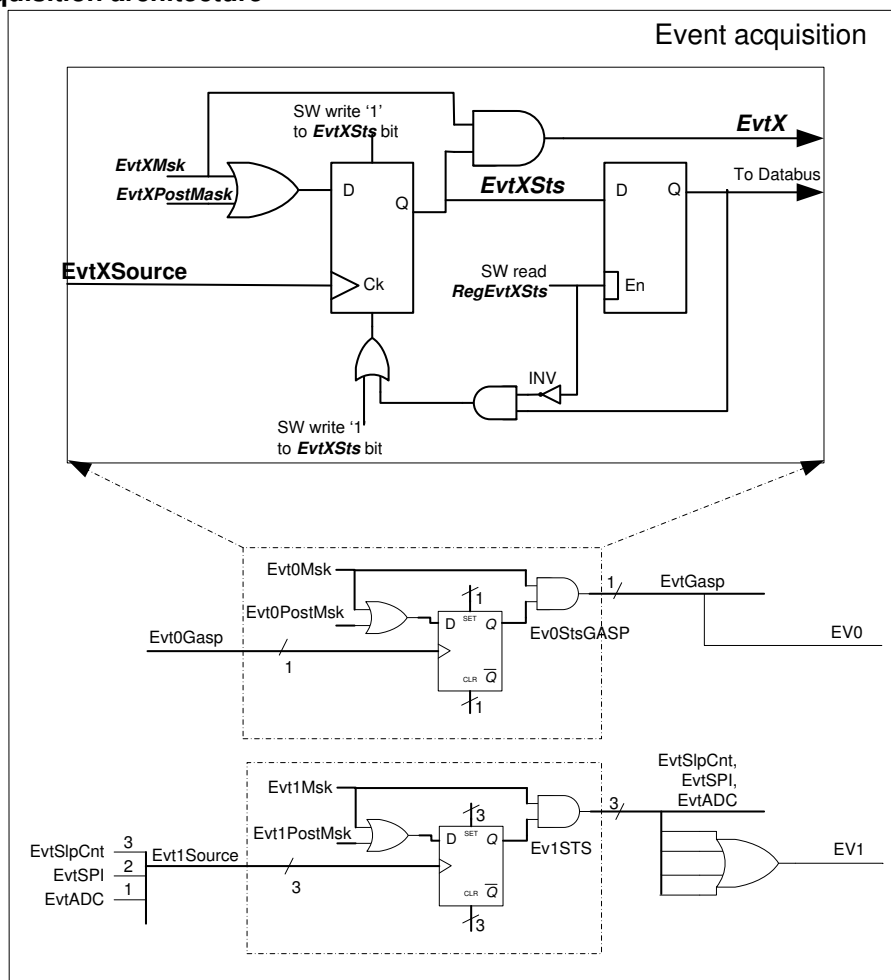

12.10 EVENT ACQUISITION CLEARING

A pending event can be cleared in 3 ways

1. Reading the event register **RegEvtSts** will automatically clear all stored events which were set prior to the read in the corresponding register.
2. Each event status bit can be individually cleared (set '0') by writing '0' to the corresponding **EvtXSts** bit. At power up or after any reset all event registers bits are reset.

12.11 SOFTWARE EVENT SETTING

Each event status bit can be individually set (set '1') by writing '1' to the corresponding **EvtXSts** bit in register **RegEvtCfg**.

12.12 EVENT REGISTERS

0x006B		RegEvtSts			Event Status
Bits	Name	Type	ResVal	ResSrc	Description
7:4	-	NI	-	-	Not implemented
3	Evt1StsSlpCnt	RW-INT	0	ResSys	Event level-1 Status - Sleep Counter
2	Evt1StsSPI	RW-INT	0	ResSys	Event level-1 Status - SPI
1	Evt1StsADC	RW-INT	0	ResSys	Event level-1 Status - ADC
0	Evt0StsGASP	RW-INT	0	ResSys	Event level-0 Status - GASP

0x006C		RegEvtCfg			Event Configuration
Bits	Name	Type	ResVal	ResSrc	Description
7	Evt1PostMskSC	RW	0	ResSys	Event level-1 Post-Mask - Sleep Counter
6	Evt1MskSC	RW	0	ResSys	Event level-1 Mask - Sleep Counter
5	Evt1PostMskSPI	RW	0	ResSys	Event level-1 Post-Mask - SPI
4	Evt1MskSPI	RW	0	ResSys	Event level-1 Mask - SPI
3	Evt1PostMskADC	RW	0	ResSys	Event level-1 Post-Mask - ADC
2	Evt1MskADC	RW	0	ResSys	Event level-1 Mask - ADC
1	Evt0PostMskGasp	RW	0	ResSys	Event level-0 Post-Mask - GASP
0	Evt0MskGasp	RW	0	ResSys	Event level-0 Mask - GASP

13. CPU INTERRUPT AND EVENT HANDLING

The CPU has three interrupt inputs of different priority. These inputs are directly connected to the peripheral interrupt acquisition block. Each of these inputs has its own interrupt vector. Individual interrupt enabling mechanism is provided for the 2 low priority inputs (IE1, IE2). The GIE acts as a master enable, if GIE is cleared no interrupt can reach the CPU, but may still be stored in the interrupt acquisition block. If the hardware stack of the CPU is full, all interrupt inputs are blocked. The number of implemented hardware stack levels is 5 but If CPU HW stack level is on level 4, only IntGASP, IntDoCPM and IntDoCDM shall generate a CPU interrupt.

Figure 11, CPU Interrupt architecture and Status register shows the architectural details concerning the interrupt and event latching and its enabling mechanism.

Figure 11, CPU Interrupt architecture and Status register block

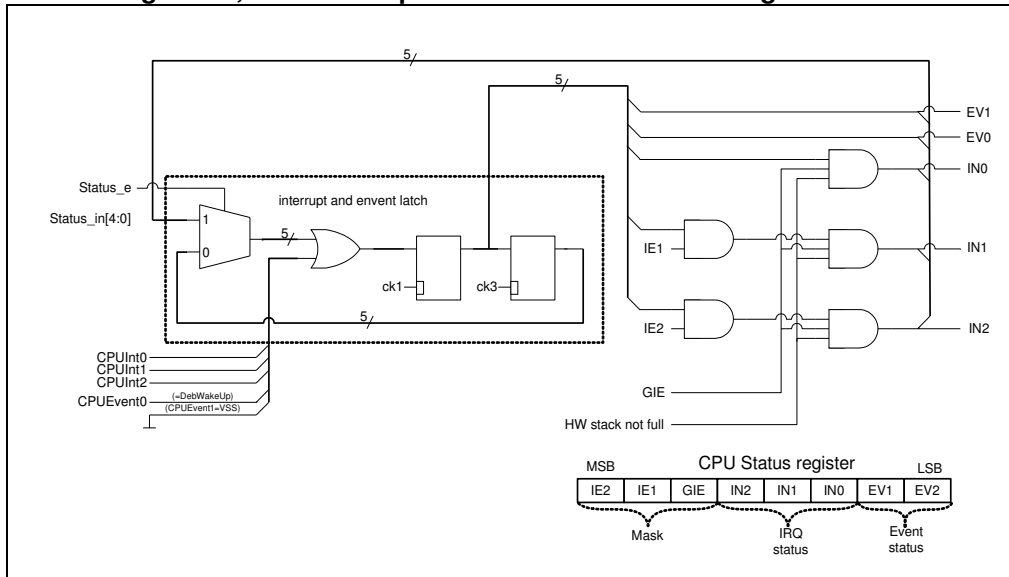

An interrupt from the peripheral acquisition block i.e. CPUInt2 is synchronized in the CPU interrupt latch and fed to the CPU interrupt handler signal IN2 if enable bits IE2 and GIE are set and the hardware stack is not full.

Same thing applies to CPUInt1. CPUInt0 is maskable only with GIE. As soon as the interrupt is latched, the GIE bit will be automatically cleared to avoid interleaved interrupts. Reading the interrupt acquisition register will clear the pending interrupt and at the end of the interrupt routine the RETI instruction will reinstall the GIE bit.

The CPU will loop in the interrupt routine as long as there is a CPU interrupt input active and the corresponding IE1, IE2 and GIE are set. Refer to 12.5 for Interrupt acquisition Clearing.

An interrupt or Event will also clear the CPU Halt mode. The HALT mode disabling remains active as long as one of the EV0, EV1, IN0, IN1, and IN2 signals is set.

Before leaving the interrupt service routine one needs to clear the active IRQ acquisition bit (inside RegIntxx) and the corresponding status bit (IN0, IN1, and IN2) in the CoolRISC status register. Failure to do so will re-invoke the interrupt service routine just after the preceding RETI instruction.

Software Interrupts and Events

The above shown CPU Interrupt handling implementation is an extension to the base structure and as such allows software interrupts and software events to be written directly in the interrupt and event latches (write '1' to CPU status register bit 0 to 4, signals status_e and status_in). Software written interrupts and events remain stored in the interrupt latch until they get cleared again (write '0' to status register bit 0 to bit 4).

13.1 INTERRUPT PRIORITY

Interrupt priority is used only to select which interrupt will be processed when multiple interrupt requests occur simultaneously. In such case the higher priority interrupt is handled first. At the end of the interrupt routine RETI the processor will immediately go back into the interrupt routine to handle the next interrupt of highest priority.

If a high priority interrupt occurs while the CPU is treating a low priority interrupt, the pending interrupt must wait until the GIE is enabled, usually by the RETI instruction.

13.2 CPU STATUS REGISTER

The status register, used to control the interrupts and events, is an internal register to the CoolRISC CPU. It therefore does not figure in the peripheral memory mapping. All CPU enable bits for the interrupts and the current status of the events and the interrupts are part of this register.

Table 5. CPU status register description

Bit	Name	Reset	Reset by	R/W	Description
7	IE2	0	ResSys	R/W	Level 2 Interrupt enable '1' = enabled, '0' = disabled
6	IE1	0	ResSys	R/W	Level 1 Interrupt enable '1' = enabled, '0' = disabled
5	GIE	0	ResSys	R/W*	General interrupt enable '1' = enabled, '0' = disabled
4	IN2	0	ResSys	R/W	Interrupt request level 2 flag, shows CPUInt2 '1' = IRQ pending, '0' = no IRQ The IRQ may only take place if IN2, IE2, and GIE are set
3	IN1	0	ResSys	R/W	Interrupt request level 1 flag, shows CPUInt1 '1' = IRQ pending, '0' = no IRQ The IRQ may only take place if IN1, IE1, and GIE are set
2	IN0	0	ResSys	R/W	Interrupt request level 0 flag, shows CPUInt1 '1' = IRQ pending, '0' = no IRQ The IRQ may only take place if IN0 and GIE are set
1	EV1	0	ResSys	R/W	Event request 1
0	EV0	0	ResSys	R/W	Event request 0

**Clear General Interrupt Enable bit GIE. Special care must be taken clearing the GIE bit. If an interrupt arrives during the clear operation the software may still branch into the interrupt routine and will set the GIE bit by the interrupt routine ending RETI instruction. This behavior may prevent from creating 'interrupt protected' areas within your code. A suitable workaround is to check if the GIE clearing took effect (Instruction) TSTB before executing the protected section.*

13.3 CPU STATUS REGISTER PIPELINE EXCEPTION

Another consequence of the above interrupt implementation is that several instruction sequences work in a different way than expected. These instructions are mostly related to interrupt and event signals. For 'normal' instructions the pipeline is completely transparent.

If an interrupt is set by software (i.e. write into the status register with a MOVE stat) the pipeline causes the next instruction to be executed before the processor jumps to the interrupt subroutine. This allows one to supply a parameter to a 'trap' as in Code shown below.

```
SETB  stat,  #4      ; trap
MOVE  a     #parameter ;
```

If an event bit is set by software (i.e. write into the CPU status register with a MOVE stat) and if a JEV (jump on event) instruction immediately follows the move, the jump on event will act as if the move has not been executed, since the write into the CPU status register will occur only once the JEV has been executed. The move takes 3 cycles to be executed and the JEV only one.

13.4 PROCESSOR VECTOR TABLE

Address 1, 2 and 3 of the program memory are reserved for interrupt subroutine calls. Generally the first four addresses of the program memory are reserved for the processor vector table. The address 0 of the program memory contains the jump to the start-up routine

Table 6. Processor vector table

Address	Accessed by	Description	Priority
0x0000	ResSys	Any reset, start-up address	Maximal, above interrupts
0x0001	IN1	Interrupt level 1	medium
0x0002	IN2	Interrupt level 2	low
0x0003	IN3	Interrupt level 0	high

13.5 CONTEXT SAVING

Since an interrupt may occur any time during normal program execution, there is no way to know which processor registers are used by the user program. For this reason, all resources modified in the interrupt service routine have to be saved upon entering and restored when leaving the service routine. The flags(C, V) and the accumulator (A) must always be saved, since most instructions will modify them. Other registers need only to be saved when they are modified in the interrupt service routine. There is a particular way to follow when saving resources. The accumulator should be saved first, followed by the flags and then the other registers

14. PORT A

The port A is general purpose 8-bit input output port. Each of the 8 Port A terminals can be configured to receive either Analog or digital Input or drive out analog or digital data.

14.1 PORT A TERMINAL MAPPING

Several digital and analog functions are mapped on the port A terminals. Please refer also to the concerned chapters.

Table 14.1-1 Port A terminal mapping

Name	IRQ	ADC	Reset	VREF	VLD	OPAMP	SPI	CLOCK	Timer clock	Timer start	PWM FrqOut
PA0	PAIRQ0	ADC0	Reset						t1ck0_in	start1_in	sig
PA1	PAIRQ1	ADC2	Reset		VLD	OPA_Out			t2ck0_in	start2_in	sig
PA2	PAIRQ2	ADC4	Reset	Vref_ADC	VLD	OPA_INM	SIN SOUT		t3ck0_in	start4_in	sig
PA3	PAIRQ3	ADC6	Reset			OPA_INP			t4ck0_in	start5_in	sig
PA4	PAIRQ4		Reset				SIN	XIN			sig
PA5	PAIRQ5		Reset								sig
PA6	PAIRQ6		Reset	Vref_out	VLD		SCLK				sig
PA7	PAIRQ7		Reset		VLD		SIN SOUT				sig

Note: on all bit of port A debouncers are enable by default after reset.

14.2 PORT A IO OPERATION

All IO modes are individually selectable for each port A terminal. Refer to table below.

Table 14.2-1 Port A IO selections

Modes	PAOE [n]	PA[n] Output data	PAOD[n]	PAPU[n]	PAPD[n]	PAInpE[n]	PA[n] Terminal	Notes
Analog signal connection (in out)	0	X	X	0	0	0	High-Z	Digital input is blocked, Analog functions can be connected CPU reads '0'
Analog signal connection (in out) with weak load to VDD or VSS	0	X	X	1	X	0	RLoad to VDD	
	0	X	X	0	1	0	RLoad to VSS	
Input mode	0	X	X	0	0	1	High-Z	Digital input, no-pull, needs external driver
Input mode with pull-up	0	X	X	1	X	1	Weak Hi	Digital input with pullup
Input mode with pull-down	0	X	X	0	1	1	Weak Lo	Digital input with pulldown
Output, CMOS high level drive	1	1	0	X	X	X	1	Pull resistors disabled
Output, CMOS low level drive	1	0	0	X	X	X	0	Pull resistors disabled
Output, open drain, high-Z	1	1	1	0	X	X	High-Z	Pull-down disabled, Usually ext Resistor pull-up
Output, open drain with pull-up	1	1	1	1	X	X	Weak Hi	Pull-up active
Output, open drain low level drive	1	0	1	X	X	X	0	Pull-up disabled

Figure 12; Port A IO configuration

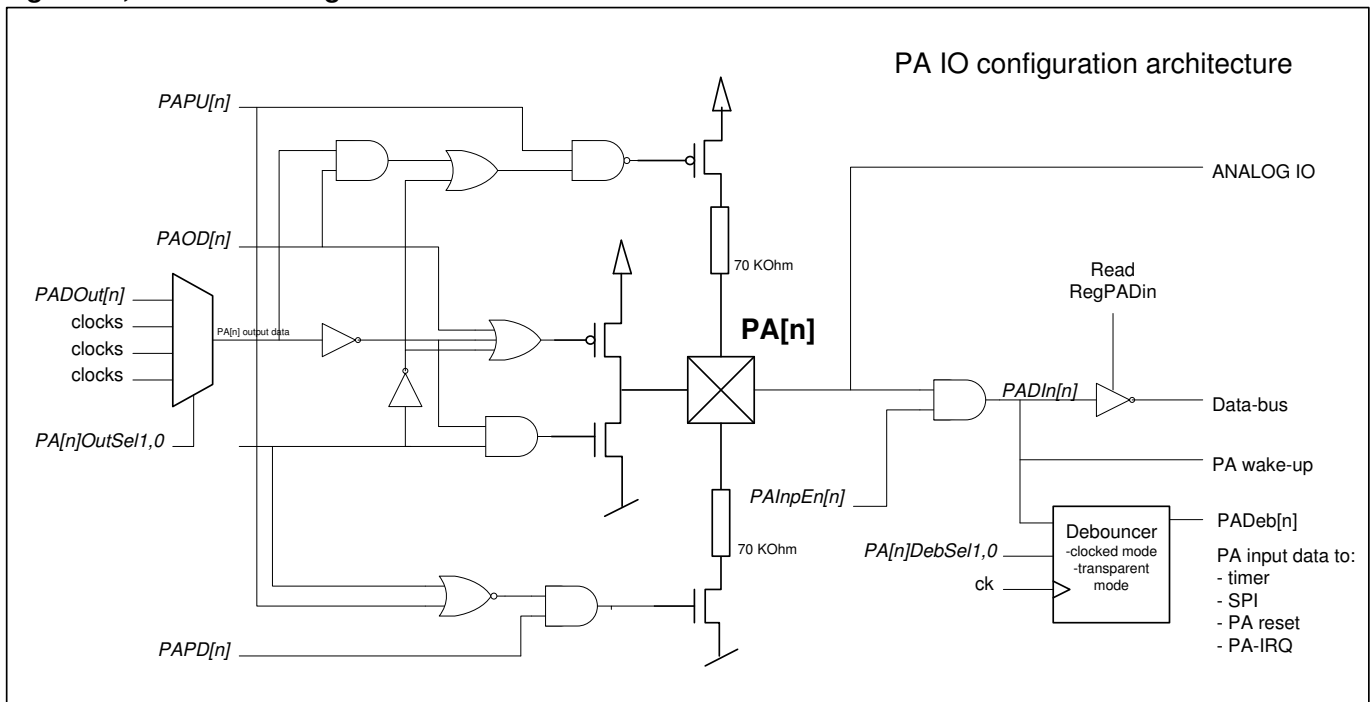

- For maximum flexibility all Port A configuration bits are fully user configurable.
- The pull resistors are only active if the pad driver is not driving the pad terminal, and pullup or pulldown resistors are enabled. Pullup has priority over pulldown.
- The CPU read of the port A terminal logic value ($PA[n]$) in register **RegPADIn** is depending of the **PAInpEn** blocking bit. As such one reads '0' if **PAInpEn='0'** (Input blocked) and the terminal logic value if **PAInpEn='1'**.
- At power-up, the $PA[n]$ terminals are tristate with pullup and pulldown resistors disconnected and the input is disabled. As such all PA terminal can float without the penalty of additional power consumption.
- All PA input signal sources for Timer, SPI, PA-Reset, PA-IRQ are coming from the debouncer output **PADeb[n]**.

Note:

Make sure to setup the terminal correctly before using it as either digital IO or as an analog connection.

14.3 OUTPUT SIGNALS ON PORT A

Different internal clock frequencies and PWM signals can be output on all port A terminals. (*PA[n] Output data*)

- The selection is done with the registers **PA[n]OutSel1,0** . All clock outputs (Pr1ckx, Pr2ckx) have a 50% duty cycle. The Clock outputs CK_x have a duty cycle corresponding to the duty cycle of their clock source.
- By default the register data **PADOut[n]** value is selected as data output.
- Data is only output if the corresponding **PAOutEn[n]** bit is high.

Table 14.3-1 Port A Output signal selection

PA0OutSel1	PA0OutSel0	PA0 Output Data	remarks
0	0	PADOut[0]	
0	1	PWM3_N	
1	0	PWM2_N	
1	1	PWM4_N	
PA1OutSel1	PA1OutSel0	PA1 Output Data	remarks
0	0	PADOut[1]	
0	1	Pr1Ck11	2kHz if CK_PR1=32kHz
1	0	PWM1	
1	1	PWM2_N	
PA2OutSel1	PA2OutSel0	PA2 Output Data	remarks
0	0	PADOut[2]	
0	1	SOUT	
1	0	PWM1	
1	1	Ck_Hi	
PA3OutSel1	PA3OutSel0	PA3 Output Data	remarks
0	0	PADOut[3]	
0	1	Ck_Lo	
1	0	Pr1Ck11	2kHz if CK_PR1=32kHz
1	1	Pr1Ck10	1kHz if CK_PR1=32kHz
PA4OutSel1	PA4OutSel0	PA4 Output Data	remarks
0	0	PA-DOut[4]	
0	1	Ck_Hi_N	
1	0	Pr2Ck6_N	125kHz if CK_PR2=2MHz
1	1	Pr2Ck4_N	31kHz if CK_PR2=2MHz
PA5OutSel1	PA5OutSel0	PA5 Output Data	remarks
0	0	PADOut[5]	
0	1	PWM3	
1	0	PWM2	
1	1	PWM4	
PA6OutSel1	PA6OutSel0	PA6 Output Data	remarks
0	0	PADOut[6]	
0	1	SCLK	
1	0	PWM1_N	
1	1	CK_8K	
PA7OutSel1	PA7OutSel0	PA7 Output Data	remarks
0	0	PADOut[7]	
0	1	SOUT	
1	0	Pr1Ck11_N	2kHz if CK_PR1=32kHz
1	1	Pr1Ck10_N	1kHz if CK_PR1=32kHz

Whereas:

- PWM3 = PWM output of timer 3 (refer to timer section)
- PWM3_N = inverse PWM output of timer 3
- Ck_Lo = Low frequency base clock (refer to clock selection)
- CK_Lo_N = inverse Low frequency base clock
- Pr1Ck11 = Prescaler 1, ck11 output (refer to prescaler)

14.4 PORT A DEBOUNCER

Each Port A input has its own debouncer with an independent clock selection. The debouncer is either transparent or clocked. The debouncer output signal is called **PADeb[n]**

- Transparent Mode: The input is immediately available on its output.
- Clocked mode: The debouncer copies its input state to its output only if during 2 consecutive debouncer clock events the debouncer input signal remains stable. The debouncer is reset on POR, by a watchdog reset and a bus error reset.

Table 14.4-1 Port A Debouncer Mode and Clock selection

PA[n]DebSel1	PA[n]DebSel0	Clock	Mode	remarks
0	0	Pr1Ck7	Clocked	Clocked; 128 Hz if ck_pr1=32kHz
0	1	Pr1Ck15	Clocked	Clocked; Pr1 input clock
1	0	Pr2Ck10	Clocked	Clocked; Pr2 input clock
1	1	no clock	Transparent	Output = Input

14.5 PORT A INTERRUPT GENERATION

Each port A input may be used as Interrupt source with individual masking possibilities.

14.5.1 PA IRQ IN ACTIVE AND STANDBY MODE

The clocked PortA interrupt is generated in the Active and Standby modes only.

- A positive or negative edge of the debouncer output signal **PADeb[n]** shall generate the **IntPA[n]**. The edge selection is done by the register bit **PAIntEdg[n]** ('1' means a positive edge and it's the default state).
- The IntPA signal is the input to the interrupt controller.(refer to the interrupt controller for Irq masking and handling).
- All interrupt settings are independent for each PA input.

14.5.2 PA IRQ IN SLEEP MODE

In Sleep mode, any edge (positive or negative) of the PA[n] input while PAInpEn[n]=1 will generate an IntPA request.

- The IntPA signal is the input to the interrupt controller.(refer to the interrupt controller for Irq masking and handling).
- All interrupt settings are independent for each PA input.

14.6 PORT A RESET FUNCTION

Each port A input can be used to generate a system reset (**ResSys** in Reset controller).

- The Port A reset signal **ResPA** is a logical OR function of all PA input reset sources after masking.
- The input signals for the port A reset function are coming from the Port A debouncer output **PADeb[n]** and can be masked individually with **RegEnResPA[n]='0'** . Default: all inputs are masked and no PA reset is generated.
- The **ResPA** is the output of the port A reset function and the input signal to the reset controller.

14.7 PORT A REGISTERS

0x000A		RegPADIn			Port-A Data Input
Bits	Name	Type	ResVal	ResSrc	Description
7:0	PADIn	RO	0x00	ResSys	Port-A Data Input

0x000B		RegPADOut			Port-A Data Output
Bits	Name	Type	ResVal	ResSrc	Description
7:0	PADOut	RW_Res	0x00	ResSys	Port-A Data Output

0x000C		RegPAInpE			Port-A Input Enable
Bits	Name	Type	ResVal	ResSrc	Description
7:0	PAInpE	RW_Res	0x00	ResAna	Port-A Input Enable

0x000D		RegPAOE			Port-A Output Enable
Bits	Name	Type	ResVal	ResSrc	Description
7:0	PAOE	RW_Res	0x00	ResAna	Port-A Output Enable

0x000E		RegPAPU			Port-A Pull Up
Bits	Name	Type	ResVal	ResSrc	Description
7:0	PAPU	RW	0x00	POR	Port-A Pull Up

0x000F		RegPAPD			Port-A Pull Down
Bits	Name	Type	ResVal	ResSrc	Description
7:0	PAPD	RW	0x00	POR	Port-A Pull Down

0x0010		RegPAOD			Port-A Open Drain
Bits	Name	Type	ResVal	ResSrc	Description
7:0	PAOD	RW	0x00	ResSys	Port-A Open Drain

0x0015		RegPAIntEdg			Port-A Interrupt Edge Selection: 1-Rising, 0-Falling
Bits	Name	Type	ResVal	ResSrc	Description
7:0	PAIntEdg	RW	0xFF	ResSys	Port-A Interrupt Edge Selection: 1-Rising, 0-Falling

0x0011		RegPAOutCfg0			Port-A Output Configuration/Selection - 0
Bits	Name	Type	ResVal	ResSrc	Description
7:6	PA3OutSel	RW	'00'	ResSys	Port-A3 Output Configuration/Selection
5:4	PA2OutSel	RW	'00'	ResSys	Port-A2 Output Configuration/Selection
3:2	PA1OutSel	RW	'00'	ResSys	Port-A1 Output Configuration/Selection
1:0	PA0OutSel	RW	'00'	ResSys	Port-A0 Output Configuration/Selection

0x0012		RegPAOutCfg1			Port-A Output Configuration/Selection - 1
Bits	Name	Type	ResVal	ResSrc	Description
7:6	PA7OutSel	RW	'00'	ResSys	Port-A7 Output Configuration/Selection
5:4	PA6OutSel	RW	'00'	ResSys	Port-A6 Output Configuration/Selection
3:2	PA5OutSel	RW	'00'	ResSys	Port-A5 Output Configuration/Selection
1:0	PA4OutSel	RW	'00'	ResSys	Port-A4 Output Configuration/Selection

0x0013		RegPADebCfg1			Port-A Deboucer Configuration - 1
Bits	Name	Type	ResVal	ResSrc	Description
7:6	PA3DebSel	RW	'00'	ResAna	PA(3) Deboucer clock Selection/Enable
5:4	PA2DebSel	RW	'00'	ResAna	PA(2) Deboucer clock Selection/Enable
3:2	PA1DebSel	RW	'00'	ResAna	PA(1) Deboucer clock Selection/Enable
1:0	PA0DebSel	RW	'00'	ResAna	PA(0) Deboucer clock Selection/Enable



0x0014		RegPADebCfg2			Port-A Deboucer Configuration - 2
Bits	Name	Type	ResVal	ResSrc	Description
7:6	PA7DebSel	RW	'00'	ResAna	PA(7) Deboucer clock Selection/Enable
5:4	PA6DebSel	RW	'00'	ResAna	PA(6) Deboucer clock Selection/Enable
3:2	PA5DebSel	RW	'00'	ResAna	PA(5) Deboucer clock Selection/Enable
1:0	PA4DebSel	RW	'00'	ResAna	PA(4) Deboucer clock Selection/Enable

0x0001		RegEnResPA			Enable Reset by PortA bits
Bits	Name	Type	ResVal	ResSrc	Description
7:0	EnResPA	RW	0x00	ResAna	Enable Reset by PortA bits

15. PORT B

The port B is general purpose 8-bit input output port. Each of the 8 Port B terminals can be configured to receive either Analog or digital Input or drive out analog or digital data.

The port B, PB7 and PB6 terminals are special inputs for device programming and debugging. These 2 ports will have special configurations as soon as TM terminal is high to allow Gasp (ISP, DoC) accesses.

15.1 PORT B TERMINAL MAPPING

Several digital and analog functions are mapped on the port B terminals. Please refer also to the concerned chapters.

Table 15.1-1 Port B terminal mapping

Name	IRQ	ADC	Reset	VREF	VLD	OPAMP	SPI	GASP	CLOCK	Timer clock	Timer start	PWM FrqOut
PB0							SIN					sig
PB1												sig
PB2							SCLK					sig
PB3												sig
PB4							SIN SOUT					sig
PB5							SIN					sig
PB6								GASP-SCK				sig
PB7								GASP-SIO				sig

15.2 PORT B IO OPERATION

All IO modes are individually selectable for each port B terminal. Refer to table below.

Table 15.2-1 Port B IO selections

Modes	PBOE [n]	PB[n] Output data	PBOD[n]	PBPU[n]	PBPD[n]	PBInpE[n]	PB[n] Terminal	Notes
Analog signal connection (in out)	0	X	X	0	0	0	High-Z	Digital input is blocked, Analog functions can be connected CPU reads '0'
Analog signal connection (in out) with weak load to VDD or VSS	0	X	X	1	X	0	RLoad to VDD	
	0	X	X	0	1	0	RLoad to VSS	
Input mode	0	X	X	0	0	1	High-Z	Digital input, no-pull, needs external driver
Input mode with pull-up	0	X	X	1	X	1	Weak Hi	Digital input with pullup
Input mode with pull-down	0	X	X	0	1	1	Weak Lo	Digital input with pulldown
Output, CMOS high level drive	1	1	0	X	X	X	1	Pull resistors disabled
Output, CMOS low level drive	1	0	0	X	X	X	0	Pull resistors disabled
Output, open drain, high-Z	1	1	1	0	X	X	High-Z	Pull-down disabled, Usually ext Resistor pull-up
Output, open drain with pull-up	1	1	1	1	X	X	Weak Hi	Pull-up active
Output, open drain drive low	1	0	1	X	X	X	0	Pull-up disabled

Figure 13; Port B IO configuration

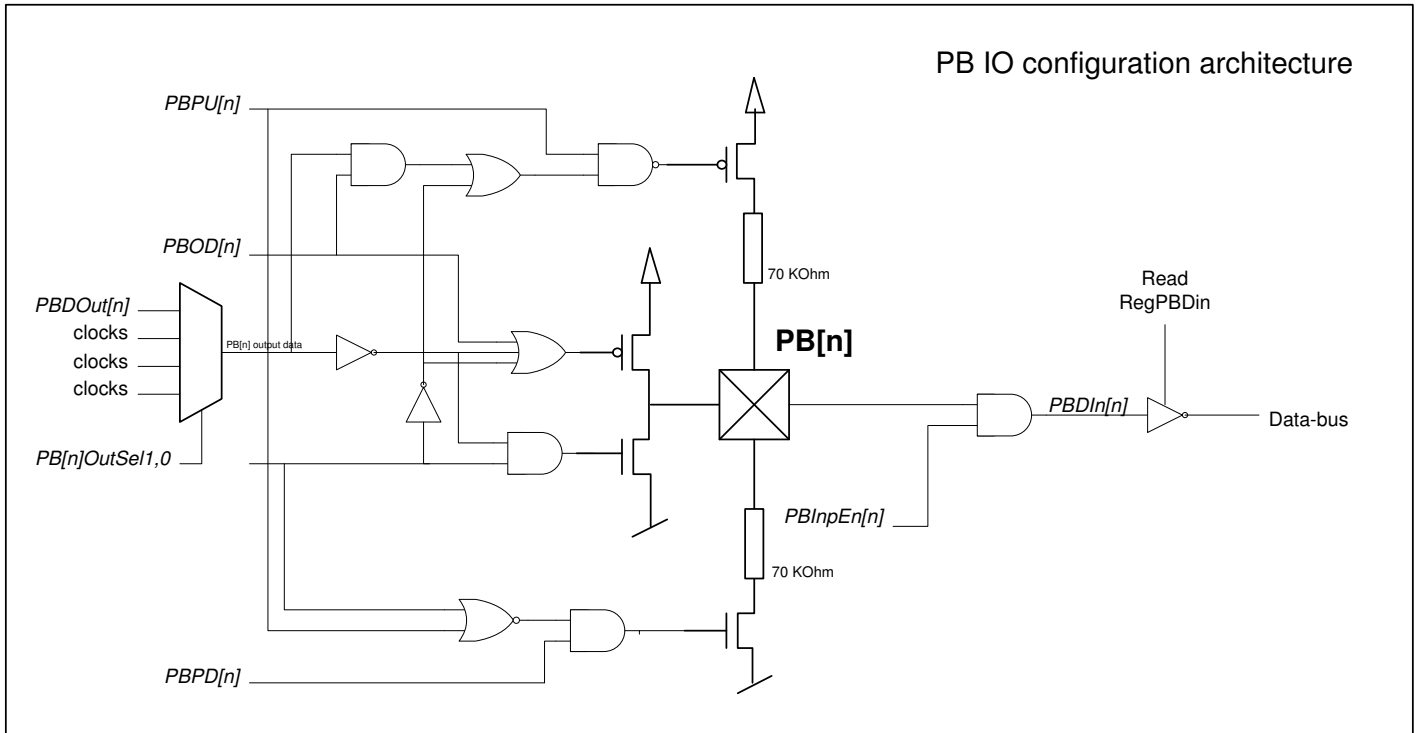

- For maximum flexibility all Port B configuration bits are fully user configurable.
- The pull resistors are only active if the pad driver is not driving the pad terminal, and pullup or pulldown resistors are enabled. Pullup has priority over pulldown.
- The CPU read of the port B terminal logic value ($PB[n]$) in register **RegPBDin** is depending of the **PBInpEn** blocking bit. As such one reads '0' if **PBInpEn='0'** (Input blocked) and the terminal logic value if **PBInpEn='1'**.
- At power-up, the $PB[n]$ terminals are tristate with pullup and pulldown resistors disconnected and the input is disabled. As such all PB terminal can float without the penalty of additional power consumption.

Note:

Make sure to setup the terminal correctly before using it..

15.2.1 GASP COMMUNICATION ON PB7, PB6

As soon as TM terminal becomes high the terminal PB7 and PB6 configurations are forced by the Gasp module without altering the port B register settings. Gasp mode has priority over normal IO mode on these 2 terminals.

15.3 OUTPUT SIGNALS ON PORT B

Different internal clock frequencies and PWM signals can be output on all port B terminals. (*PB[n] Output data*)

- The selection is done with the registers **PB[n]OutSel1,0** . All clock outputs (Pr1ckx, Pr2ckx) have a 50% duty cycle. The Clock outputs CK_x have a duty cycle corresponding to the duty cycle of their clock source.
- By default the register data **PBDOut[n]** value is selected as data output.
- Data is only output if the corresponding **PBOutEn[n]** bit is high.

Table 15.3-1 Port B Output signal selection

PB0OutSel1	PB0OutSel0	PB0 Output Data	remarks
0	0	PBDOUT[0]	
0	1	PWM3	
1	0	PWM2	
1	1	PWM4	
PB1OutSel1	PB1OutSel0	PB1 Output Data	remarks
0	0	PBDOUT[1]	
0	1	PWM3_N	
1	0	PWM2_N	
1	1	PWM4_N	
PB2OutSel1	PB2OutSel0	PB2 Output Data	remarks
0	0	PBDOUT[2]	
0	1	SCLK	
1	0	PWM1	
1	1	PWM3	
PB3OutSel1	PB3OutSel0	PB3 Output Data	remarks
0	0	PBDOUT[3]	
0	1	CK_Hi	
1	0	PWM1_N	
1	1	PWM3_N	
PB4OutSel1	PB4OutSel0	PB4 Output Data	remarks
0	0	PBDOUT[4]	
0	1	SOUT	
1	0	PWM1	
1	1	PWM3	
PB5OutSel1	PB5OutSel0	PB5 Output Data	remarks
0	0	PBDOUT[5]	
0	1	PWM3	
1	0	PWM2	
1	1	PWM4	
PB6OutSel1	PB6OutSel0	PB6 Output Data	remarks
0	0	PBDOUT[6]	
0	1	PWM1_N	
1	0	PWM3_N	
1	1	Pr1Ck11	2kHz if CK_PR1=32kHz
PB7-OutSel1	PB7-OutSel0	PB7 Output Data	remarks
0	0	PBDOUT[7]	
0	1	PWM1	
1	0	PWM3	
1	1	Pr1Ck10	1kHz if CK_PR1=32kHz

Whereas:

- PWM3 = PWM output of timer 3 (refer to timer section)
- PWM3_N = inverse PWM output of timer 3
- Ck_Hi = High frequency base clock (refer to clock selection)
- Pr1Ck10 = Prescaler 1, ck10 output (refer to prescaler)

15.4 PORT B REGISTERS

0x0016		RegPBDIn			Port-B Data Input
Bits	Name	Type	ResVal	ResSrc	Description
7:0	PBDIn	RO	0x00	ResSys	Port-B Data Input

0x0017		RegPBDOOut			Port-B Data Output
Bits	Name	Type	ResVal	ResSrc	Description
7:0	PBDOOut	RW_Res	0x00	ResSys	Port-B Data Output

0x0018		RegPBInpE			Port-B Input Enable
Bits	Name	Type	ResVal	ResSrc	Description
7:0	PBInpE	RW_Res	0x00	ResSys	Port-B Input Enable

0x0019		RegPBOE			Port-B Output Enable
Bits	Name	Type	ResVal	ResSrc	Description
7:0	PBOE	RW_Res	0x00	ResSys	Port-B Output Enable

0x001A		RegPBPU			Port-B Pull Up
Bits	Name	Type	ResVal	ResSrc	Description
7:0	PBPU	RW_Res	0x00	POR	Port-B Pull Up

0x001B		RegPBPD			Port-B Pull Down
Bits	Name	Type	ResVal	ResSrc	Description
7:0	PBPD	RW_Res	0x00	POR	Port-B Pull Down

0x001C		RegPBOD			Port-B Open Drain
Bits	Name	Type	ResVal	ResSrc	Description
7:0	PBOD	RW_Res	0x00	ResSys	Port-B Open Drain

0x001D		RegPBOutCfg0			Port-B Output Configuration/Selection - 0
Bits	Name	Type	ResVal	ResSrc	Description
7:6	PB3OutSel	RW	'00'	ResSys	Port-B3 Output Configuration/Selection
5:4	PB2OutSel	RW	'00'	ResSys	Port-B2 Output Configuration/Selection
3:2	PB1OutSel	RW	'00'	ResSys	Port-B1 Output Configuration/Selection
1:0	PB0OutSel	RW	'00'	ResSys	Port-B0 Output Configuration/Selection

0x001E		RegPBOutCfg1			Port-B Output Configuration/Selection - 1
Bits	Name	Type	ResVal	ResSrc	Description
7:6	PB7OutSel	RW	'00'	ResSys	Port-B7 Output Configuration/Selection
5:4	PB6OutSel	RW	'00'	ResSys	Port-B6 Output Configuration/Selection
3:2	PB5OutSel	RW	'00'	ResSys	Port-B5 Output Configuration/Selection
1:0	PB4OutSel	RW	'00'	ResSys	Port-B4 Output Configuration/Selection

16. PORT C

The port C is general purpose 8-bit input output port. Each of the 8 Port C terminals can be configured to receive either Analog or digital Input or drive out analog or digital data.

16.1 PORT C TERMINAL MAPPING

Several digital and analog functions are mapped on the port C terminals. Please refer also to the concerned chapters.

Table 16.1-1 Port C terminal mapping

Name	IRQ	ADC	Reset	VREF	VLD	OPAMP	SPI	CLOCK	Timer clock	Timer start	PWM FrqOut
PC0	PCIRQ0	ADC1									sig
PC1	PCIRQ1	ADC3			VLD	OPA_Out			t2ck1_in	start3_in	sig
PC2	PAIRQ2	ADC5				OPA_INM	SIN SOUT				sig
PC3	PCIRQ3	ADC7				OPA_INP			t4ck1_in	start6_in	sig
PC4	PCIRQ4							XOUT ExtCk			sig
PC5	PCIRQ5				VLD						sig
PC6	PCIRQ6				VLD		SCLK		t1ck1_in	start7_in	sig
PC7	PCIRQ7								t3ck1_in		sig

16.2 PORT C IO OPERATION

All IO modes are individually selectable for each port C terminal. Refer to table below.

Table 16.2-1 Port C IO selections

Modes	PCOE [n]	PC[n] Output data	PCOD[n]	PCPU[n]	PCPD[n]	PCInpE[n]	PC[n] Terminal	Notes
Analog signal connection (in out)	0	X	X	0	0	0	High-Z	Digital input is blocked, Analog functions can be connected CPU reads '0'
Analog signal connection (in out) with weak load to VDD or VSS	0	X	X	1	X	0	RLoad to VDD	
	0	X	X	0	1	0	RLoad to VSS	
Input mode	0	X	X	0	0	1	High-Z	Digital input, no-pull, needs external driver
Input mode with pull-up	0	X	X	1	X	1	Weak Hi	Digital input with pullup
Input mode with pull-down	0	X	X	0	1	1	Weak Lo	Digital input with pulldown
Output, CMOS high level drive	1	1	0	X	X	X	1	Pull resistors disabled
Output, CMOS low level drive	1	0	0	X	X	X	0	Pull resistors disabled
Output, open drain, high-Z	1	1	1	0	X	X	High-Z	Pull-down disabled, Usually ext Resistor pull-up
Output, open drain with pull-up	1	1	1	1	X	X	Weak Hi	Pull-up active
Output, open drain drive low	1	0	1	X	X	X	0	Pull-up disabled

Note: on all bit of port C debouncers are enable by default after reset,

Figure 14; Port C IO configuration

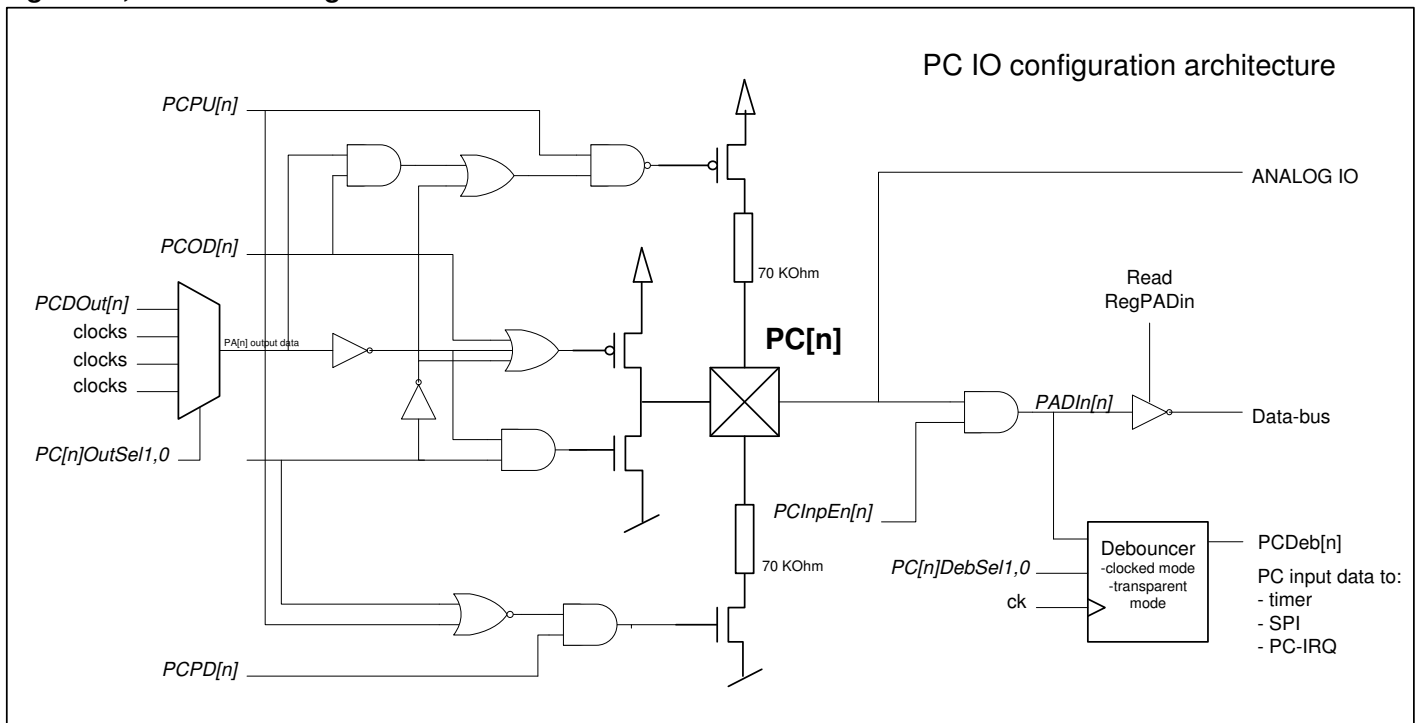

- For maximum flexibility all Port C configuration bits are fully user configurable.
- The pull resistors are only active if the pad driver is not driving the pad terminal, and pullup or pulldown resistors are enabled. Pullup has priority over pulldown.
- The CPU read of the port C terminal logic value ($PC[n]$) in register **RegPCDIn** is depending of the **PCInpEn** blocking bit. As such one reads '0' if **PCInpEn='0'** (Input blocked) and the terminal logic value if **PCInpEn='1'**.
- At power-up, the $PC[n]$ terminals are tristate with pullup and pulldown resistors disconnected and the input is disabled. As such all PC terminal can float without the penalty of additional power consumption.
- All PC input signal sources for Timer, SPI, PC-IRQ are coming from the debouncer output **PCDeb[n]**.

Note:

Make sure to setup the terminal correctly before using it as either digital IO or as an analog connection.

16.3 OUTPUT SIGNALS ON PORT C

Different internal clock frequencies and PWM signals can be output on all port C terminals. (*PA[n] Output data*)

- The selection is done with the registers **PC[n]OutSel1,0** . All clock outputs (Pr1ckx, Pr2ckx) have a 50% duty cycle. The Clock outputs CK_x have a duty cycle corresponding to the duty cycle of their clock source.
- By default the register data **PCDOut[n]** value is selected as data output.
- Data is only output if the corresponding **PCOutEn[n]** bit is high.

Table 16.3-1 Port C Output signal selection

PC0OutSel1	PC0OutSel0	PC0 Output Data	remarks
0	0	PCDOUT[0]	
0	1	Pr2Ck6	125kHz if CK_PR2=2MHz
1	0	Pr2Ck4	31kHz if CK_PR2=2MHz
1	1	Pr2Ck0	2kHz if CK_PR2=2MHz
PC1OutSel1	PC1OutSel0	PC1 Output Data	remarks
0	0	PCDOUT[1]	
0	1	PWM4_N	
1	0	PWM1_N	
1	1	PWM3_N	
PC2OutSel1	PC2OutSel0	PC2 Output Data	remarks
0	0	PCDOUT[2]	
0	1	SOUT	
1	0	PWM1_N	
1	1	Ck_Lo	
PC3OutSel1	PC3OutSel0	PC3 Output Data	remarks
0	0	PCDOUT[3]	
0	1	CK_LO_N	
1	0	Pr1Ck11_N	2kHz if CK_PR1=32kHz
1	1	Pr1Ck10_N	1kHz if CK_PR1=32kHz
PC4OutSel1	PC4OutSel0	PC4 Output Data	remarks
0	0	PCDOUT[4]	
0	1	Ck_Hi	
1	0	Pr2Ck6	125kHz if CK_PR2=2MHz
1	1	Pr2Ck4	31kHz if CK_PR2=2MHz
PC5OutSel1	PC5OutSel0	PC5 Output Data	remarks
0	0	PCDOUT[5]	
0	1	CK_8K	
1	0	Pr2Ck6	125kHz if CK_PR2=2MHz
1	1	Pr2Ck4	31kHz if CK_PR2=2MHz
PC6OutSel1	PC6OutSel0	PC6 Output Data	remarks
0	0	PCDOUT[6]	
0	1	SCLK	
1	0	PWM1_N	
1	1	ck_lo	
PC7OutSel1	PC7OutSel0	PC7 Output Data	remarks
0	0	PCDOUT[7]	
0	1	PWM1	
1	0	PWM3_N	
1	1	Pr1Ck12	4kHz if CK_PR1=32kHz

Whereas:

- PWM1 = PWM output of timer 1 (refer to timer section)
- PWM1_N = inverse PWM output of timer 1
- Ck_Hi = High frequency base clock (refer to clock selection)
- Pr1Ck12 = Prescaler 1, ck12 output (refer to prescaler)

16.4 PORT C DEBOUNCER

Each Port C input has its own debouncer with an independent clock selection. The debouncer is either transparent or clocked. The debouncer output signal is called **PCDeb[n]**.

- Transparent Mode: The input is immediately available on its output.
- Clocked mode: The debouncer copies its input state to its output only if during 2 consecutive debouncer clock events the debouncer input signal remains stable. The debouncer is reset on POR, by a watchdog reset and a bus error reset.

Table 16.4-1 Port C Debouncer Mode and Clock selection

PC[n]DebSel1	PC[n]DebSel0	Clock	Mode	remarks
0	0	Pr1Ck7	Clocked	Clocked; 128 Hz if ck_pr1=32kHz
0	1	Pr1Ck15	Clocked	Clocked; Pr1 input clock
1	0	Pr2Ck10	Clocked	Clocked; Pr2 input clock
1	1	no clock	Transparent	Output = Input

16.5 PORT C INTERRUPT GENERATION

Each port C input may be used as Interrupt source with individual masking possibilities.

16.5.1 PC IRQ IN ACTIVE AND STANDBY MODE

The clocked port C interrupt is generated in the Active and Standby modes only.

- A positive or negative edge of the debouncer output signal **PCDeb[n]** shall generate the **IntPC[n]** interrupt request. The edge selection is done by the register bit **PCIntEdg[n]** ('1' means a positive edge and it's the default state).
- The IntPC signal is the input to the interrupt controller. (Refer to the interrupt controller for Irq masking and handling).
- All interrupt settings are independent for each PC input.

16.5.2 PC IRQ IN SLEEP MODE

There is no port C interrupt possibility in Sleep mode. Port C interrupt input will automatically switch to the corresponding port A in Sleep mode. Refer also to the interrupt controller section 10

16.6 PORT C REGISTERS

0x001F		RegPCDin			Port-C Data Input
Bits	Name	Type	ResVal	ResSrc	Description
7:0	PCDIn	RO	0x00	ResSys	Port-C Data Input

0x0020		RegPCDOut			Port-C Data Output
Bits	Name	Type	ResVal	ResSrc	Description
7:0	PCDOut	RW_Res	0x00	ResSys	Port-C Data Output

0x0021		RegPCInpE			Port-C Input Enable
Bits	Name	Type	ResVal	ResSrc	Description
7:0	PCInpE	RW_Res	0x00	ResSys	Port-C Input Enable

0x0022		RegPCOE			Port-C Output Enable
Bits	Name	Type	ResVal	ResSrc	Description
7:0	PCOE	RW_Res	0x00	ResSys	Port-C Output Enable

0x0023		RegPCPU			Port-C Pull Up
Bits	Name	Type	ResVal	ResSrc	Description
7:0	PCPU	RW_Res	0x00	POR	Port-C Pull Up

0x0024		RegPCPD			Port-C Pull Down
Bits	Name	Type	ResVal	ResSrc	Description
7:0	PCPD	RW_Res	0x00	POR	Port-C Pull Down

0x0025		RegPCOD			Port-C Open Drain
Bits	Name	Type	ResVal	ResSrc	Description
7:0	PCOD	RW_Res	0x00	ResSys	Port-C Open Drain

0x002A		RegPCIntEdg			Port-C Interrupt Edge Selection: 1-Rising, 0-Falling
Bits	Name	Type	ResVal	ResSrc	Description
7:0	PCIntEdg	RW	0xFF	ResSys	Port-C Interrupt Edge Selection: 1-Rising, 0-Falling

0x0026		RegPCOutCfg0			Port-C Output Configuration/Selection - 0
Bits	Name	Type	ResVal	ResSrc	Description
7:6	PC3OutSel	RW	'00'	ResSys	Port-C3 Output Configuration/Selection
5:4	PC2OutSel	RW	'00'	ResSys	Port-C2 Output Configuration/Selection
3:2	PC1OutSel	RW	'00'	ResSys	Port-C1 Output Configuration/Selection
1:0	PC0OutSel	RW	'00'	ResSys	Port-C0 Output Configuration/Selection

0x0027		RegPCOutCfg1			Port-C Output Configuration/Selection - 1
Bits	Name	Type	ResVal	ResSrc	Description
7:6	PC7OutSel	RW	'00'	ResSys	Port-C7 Output Configuration/Selection
5:4	PC6OutSel	RW	'00'	ResSys	Port-C6 Output Configuration/Selection
3:2	PC5OutSel	RW	'00'	ResSys	Port-C5 Output Configuration/Selection
1:0	PC4OutSel	RW	'00'	ResSys	Port-C4 Output Configuration/Selection

0x0028		RegPCDebCfg1			Port-C Deboucer Configuration - 1
Bits	Name	Type	ResVal	ResSrc	Description
7:6	PC3DebSel	RW	'00'	ResSys	PC(3) Deboucer clock Selection/Enable
5:4	PC2DebSel	RW	'00'	ResSys	PC(2) Deboucer clock Selection/Enable
3:2	PC1DebSel	RW	'00'	ResSys	PC(1) Deboucer clock Selection/Enable
1:0	PC0DebSel	RW	'00'	ResSys	PC(0) Deboucer clock Selection/Enable



0x0029		RegPCDebCfg2			Port-C Deboucer Configuration - 2
Bits	Name	Type	ResVal	ResSrc	Description
7:6	PC7DebSel	RW	'00'	ResSys	PC(7) Deboucer clock Selection/Enable
5:4	PC6DebSel	RW	'00'	ResSys	PC(6) Deboucer clock Selection/Enable
3:2	PC5DebSel	RW	'00'	ResSys	PC(5) Deboucer clock Selection/Enable
1:0	PC4DebSel	RW	'00'	ResSys	PC(4) Deboucer clock Selection/Enable

17. TIMERS

The circuit contains 4 independent 8-bit timers configurable as 2 16-bit timers.

- Each of it can be individually configured with:
- 6 internal clock sources and 2 external clock sources from PA, PC terminals
- Individual Start/Stop selection by SW or from various IO terminals
- Timer interrupt selection
- Auto-reload(free-running) and Auto-Stop mode
- Input Capture on hardware events (terminal input) or SW driven
- Output Compare for signal generation
- PWM and Frequency output
- RTZ, RTO output clock capabilities
- Timer outputs mapping on various IO terminals
- Always also provides complementary level output to increase overall voltage swing.

The timers are implemented as up-counters, counting from 0x00 to **RegTimXFull** or as a free running counter cycling from 0x00 to **RegTimXFull**. If the full value changes while the timer is running, the previous full value will be used for the full event detection. The new full value will be used for the next counting cycle.

The timer status value (actual count value) is readable in registers **RegTimXStatus**.

17.1 TIMER CHAINING

Possible configurations are:

- Timer1, Timer2, Timer3, Timer4 used independently
- Timer1 and Timer2 chained together (Timer12); Timer3 and Timer 4 used independently
- Timer1 and Timer2 used independently; Timer3 and Timer4 chained (=Timer34)
- Timer1 and Timer2 chained together (Timer12); Timer3 and Timer4 chained (=Timer34)

Timer1 and Timer2 are chained and able to work as 16-bits timer when **Tim12Chain** in **RegTimersCfg** is high. In this case, the configuration is set by the Timer1 and Timer2 (slave) is the MSB.

Timer3 and Timer4 are chained and able to work as 16-bits timer when **Tim34Chain** in **RegTimersCfg** is high. In this case, the configuration is set by the Timer3 and Timer4 (slave) is the MSB.

Figure 15, Timer chaining

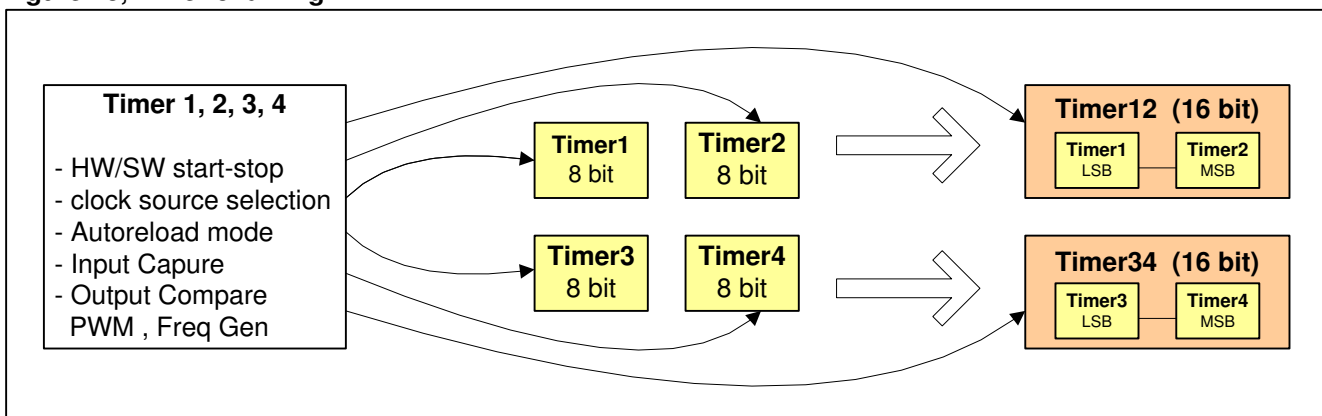

17.2 TIMER CLOCK SOURCES

The timer clock inputs connect directly to the prescaler1 and prescaler2 outputs. The prescalers themselves connect to **Ck_Hi** or **Ck_Lo** which are derived from the internal RC oscillators or the external clock sources from XTAL, Resonator or PC4 input. Please refer to the chapter Clock selection and Clock switching for more details about the basic clock setup.

Additionally to the prescaler clock sources the timers may also run on 2 external clocks sources, one from PA the other from PC.

The clock source selection is done in registers **RegTimXCfg** bits **TimXSelClk** as follows (X stands for 1,2,3,4)

Table 17.2-1 Timer clock configuration

Tim1SelClk [2:0]	Timer1, Timer12	Tim2SelClk [2:0]	Timer2	Tim3SelClk [2:0]	Timer3, Timer34	Tim4SelClk [2:0]	Timer4
000	PA0	000	PA1	000	PA2	000	PA3
001	PC6	001	PC1	001	PC7	001	PC3
010	Pr2Ck10	010	Pr2Ck10	010	Pr2Ck10	010	Pr2Ck10
011	Pr2Ck8	011	Pr1Ck15	011	Pr2Ck8	011	Pr1Ck15
100	Pr2Ck6	100	Pr1Ck14	100	Pr2Ck4	100	Pr1Ck13
101	Pr1Ck15	101	Pr1Ck12	101	Pr1Ck15	101	Pr1Ck11
110	Pr1Ck13	110	Pr1Ck10	110	Pr1Ck13	110	Pr1Ck9
111	Pr1Ck11	111	Pr1Ck8	111	Pr1Ck9	111	Pr1Ck7

Maximal external timer input clock frequency must be lower than to **Ck_Hi/2** or **Ck_Lo/2** if Ck_Hi is not used.

Table 17.2-2 Timer clock configuration overview (decimal values of TimXSelClk)

TimXSelClk [2:0]	Tim1-Ck, Tim12-Ck	Tim2-Ck	Tim3-Ck, Tim34-Ck	Tim4-Ck
Timer ck selection to Prescaler 1 freq				
Pr1Ck15	5	3	5	3
Pr1Ck14		4		
Pr1Ck13	6		6	4
Pr1Ck12		5		
Pr1Ck11	7			5
Pr1Ck10		6		
Pr1Ck9			7	6
Pr1Ck8		7		
Pr1Ck7				7
Timer ck selection to Prescaler 2 freq				
Pr2Ck10	2	2	2	2
Pr2Ck9				
Pr2Ck8	3		3	
Pr2Ck7				
Pr2Ck6	4			
Pr2Ck5				
Pr2Ck4			4	
Timer ck selection to PA input clocks				
PA[0]	0			
PA[1]		0		
PA[2]			0	
PA[3]				0
PC[1]		1		
PC[3]				1
PC[6]	1			
PC[7]			1	

17.3 TIMER START

The timers can be started and stopped by SW or hardware events. To be able to start the **RegTimXFull** value must not be equal to 0x00.

All timer settings must be performed before starting the timer.

The timer start and stop selection are done in registers **RegTimXCfg** bits **TimXSelStart** as follows:

Table 17.3-1 Timer start selection

TimXSelStart [2:0]	Timer1, Timer12	Timer2	Timer3, Timer34	Timer4
000	SW start	SW start	SW start	SW start
Hardware start - stop selections				
001	PA0	PA0	PA0	PA0
010	PA1	PA1	PA1	PA1
011	PC1	PC1	PC1	PC1
100	PA2	PA2	PA2	PA2
101	PA3	PA3	PA3	PA3
110	PC3	PC3	PC3	PC3
111	PC6	PC6	PC6	PC6

Notes:

External start/stop signal must be glitch free and debouncer should be used to ensure that no glitch might be propagated to the timer

- If the debouncer is used, then start/stop pulse width should be longer than 2 clock periods of the debouncer, otherwise incoming pulse is ignored.
- Minimal pulse width of external start/stop signal has to be longer than one timer clock period when debouncer is bypassed.

Figure 16, Timer SW and Hardware (Pulse, Period) Start-Stop

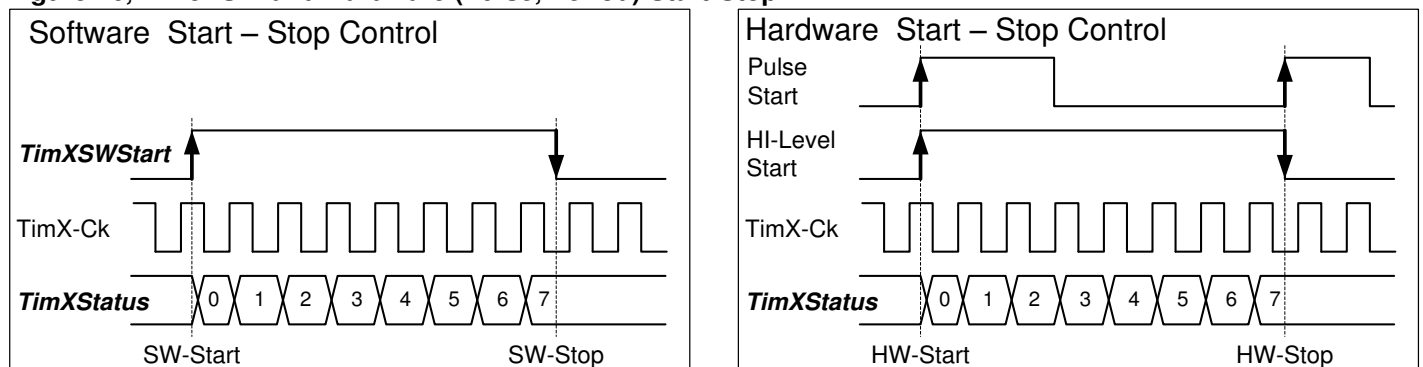

17.3.1 SOFTWARE START - STOP

In case of software start selection (**TimXSelStart**'=000') the timers will start counting from 0x00 as soon as **TimXSWStart** in **RegTimersStart** goes to high level.

When **TimXSWStart** goes to low level, the timerX will stop counting and **RegTimXStatus** keeps its status value.

17.3.2 HARDWARE START - STOP (PERIOD COUNTING)

In case of hardware start selection (**TimXSelStart** <> 000) and **TimXPulse** in **RegTimersStart** is high, the timer will start counting from 0x00 as soon as the selected external start input **ExtTimXStart** goes to high level. When another pulse occurs on **ExtTimXStart**, timerX shall stop to count and **RegTimXStatus** keeps its status.

Notes:

External start/stop period must be glitch free and debouncer should be used to ensure that no glitch might be propagated to the timer

- *If the debouncer is used then the pulses width (pulse at '1' and pulse at '0') should be longer than two clock periods of the debouncer, (otherwise incoming pulse is lost - ignored).*
- *When the debouncer is bypassed, the period of the measured signal has to be longer than one timer clock period: the timer is able to count the period of the incoming signal if its period is longer than one timer clock period (otherwise the timer is reloaded only).*
- *These two conditions need to be fulfilled when the debouncer is enabled and external period need to be measured*

17.3.3 HARDWARE START – STOP (PULS COUNTING)

In case of hardware start selection (**TimXSelStart** <> '000') and **TimXPulse** in **RegTimersStart** is low, the timer will start counting from 0x00 on the first positive pulse on the selected external start input **ExtTimXStart**. When **ExtTimXStart** goes back to low level, timerX will stop to count and **RegTimXStatus** keeps its status.

Notes:

External start/stop pulse must be glitch free and debouncer should be used to ensure that no glitch might be propagated to the timer

If the debouncer is used then the pulse width should be longer than two clock periods of debouncer (otherwise incoming pulse is lost - ignored)

When the debouncer is bypassed, the start/stop signal pulse width (pulse measurement) has to be longer than one timer clock period: the timer is able to count the pulse width of the incoming signal if its width is longer than one timer clock period (otherwise the timer is reloaded only).

These two conditions need to be fulfilled when the debouncer is enabled and external pulse width need to be measured

17.4 AUTO-RELOAD MODE

In autoreload mode the timerX always restart counting from 0x00 once its status reaches **TimXFull** value. It will act as a free running counter.

Going into Auto-reload mode:

- By setting the corresponding **TimXAR** bit in register **RegTimersCfg** at high level.

Canceling Auto-Reload mode

- By a system reset, stop immediately, **TimXStatus** cleared.
- By a removed start condition, stop immediately, **TimXStatus** maintained.
- By **TimXAR** written to '0', stop after reaching **TimXFull** value.

Figure 17, Sample waveforms in Auto-Reload mode

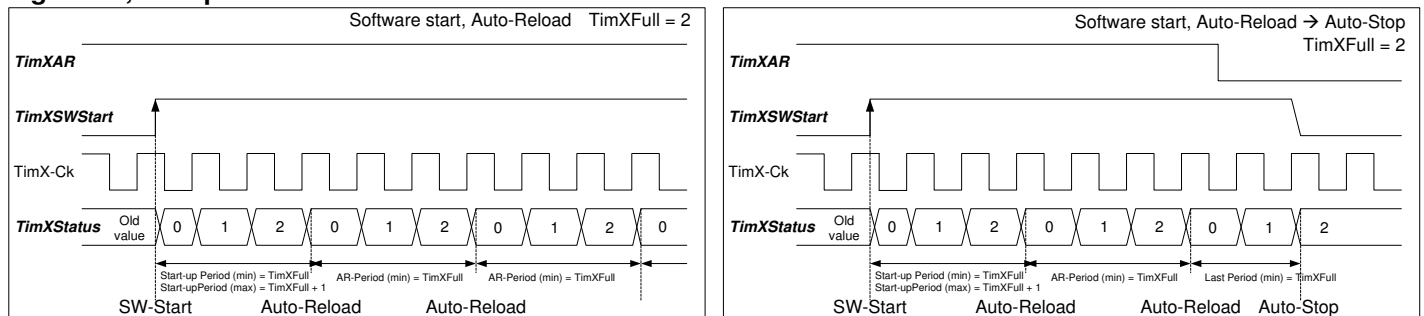

17.5 AUTO-STOP MODE

In auto-stop mode the timerX counts from 0x00 until it reaches **TimXFull** value.

Going into Auto-Stop mode:

- By setting the corresponding **TimXAR** bit in register **RegTimersCfg** at low level.

Stopping the timer

- By a system reset, stop immediately, **TimXStatus** cleared.
- Removed Start condition, stop immediately, **TimXStatus** maintained.
- The timerX automatically stops when reaching **TimXFull** value.

Figure 18, Sample waveforms in Auto-Stop mode

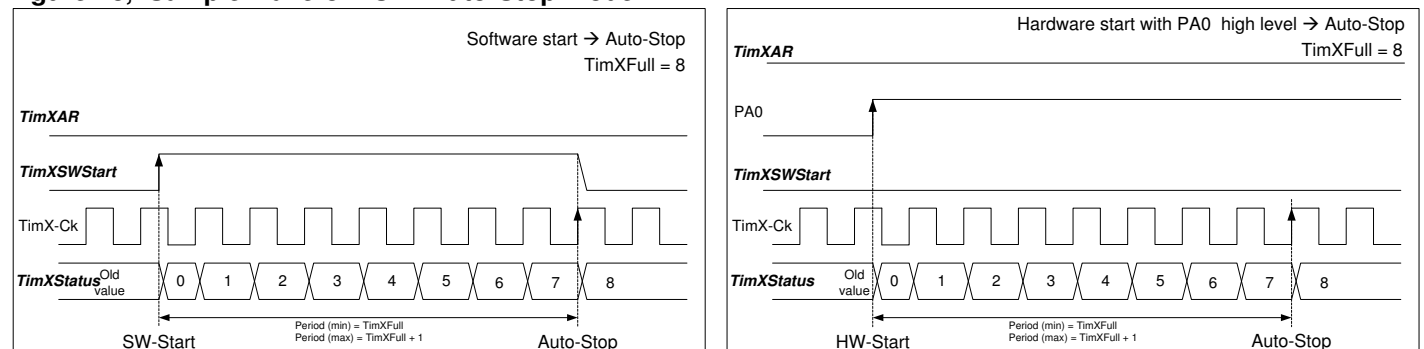

17.6 TIMER INPUT CAPTURE

The input capture system allows taking a timer snapshot based on an internal SW event or an external hardware event by writing the timer status value into the capture register at the occurrence of the capture event.

An Interrupt *IntTimX* is generated on all active hardware capture events. Capture events are ignored if the timer is not running.

Valid capture events are:

- Software SW capture (on Timer1, Timer12, Timer3 and Timer34 only)
- Hardware capture on all timers, Falling edge
- Hardware capture on all timers, Rising edge
- Hardware Capture on all timers, Both edges

In SW capture, the event is generated by writing '1' to the bit **Tim1SWCpt** in register **RegTimersCfg.Tim1SWCpt** Timer3 by writing '1' to the bit **Tim3SWCpt** in register **RegTimersCfg.Tim3SWCpt**.

In hardware capture the active capture inputs are selected in register **RegTimXCptCmpCfg** bits **TimXCptCptEvtSrc** as follows:

Tim1CptEvtSrc[1:0]	External event	Tim2CptEvtSrc[1:0]	External event
00	PA2	00	PA2
01	COMP	01	PA1
10	VLD	10	PA3
11	PA1	11	VLD

Tim3CptEvtSrc[1:0]	External event	Tim4CptEvtSrc[1:0]	External event
00	PA2	00	PC7
01	COMP	01	PC0
10	PC4	10	PA0
11	PA3	11	VLD

In hardware capture the active edge(s) of the selected event source is defined by register **RegTimXCptCmpCfg** bits **TimXCptEdg** as follows:

TimXCptEdg	Selected edge for event signal
00	no action
01	falling edge
10	rising egde
11	both edges

Figure 19, Input Capture Architecture

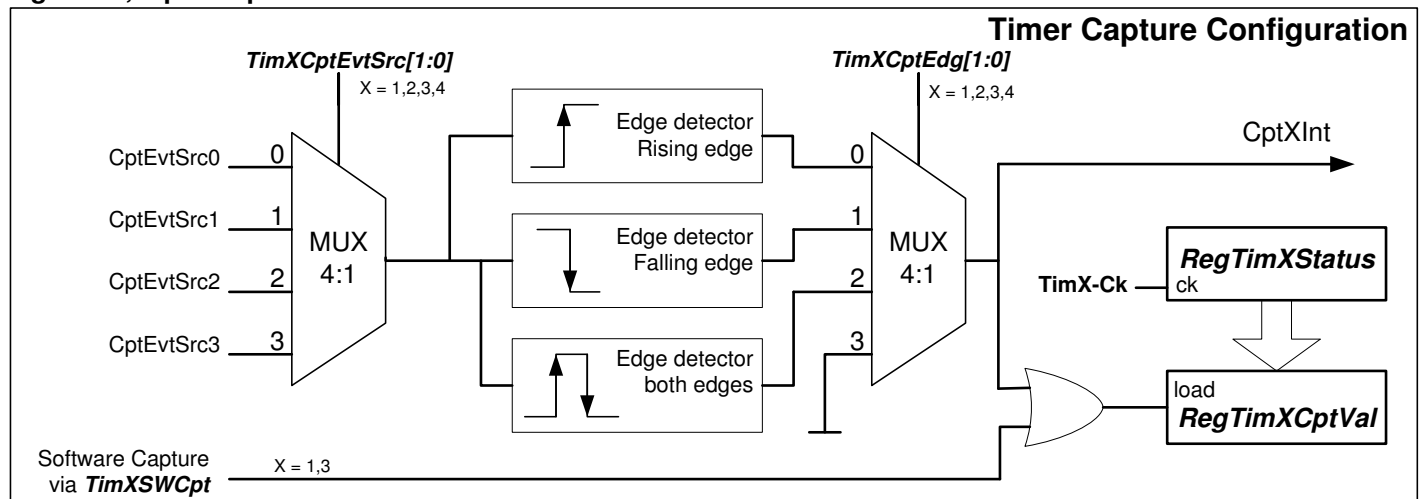

Notes:



External input capture event must be glitch free and debouncer should be used to ensure that no glitch might be propagated to the timer

- If the debouncer is used then the pulse width of external capture signal should be longer than two clock periods of the debouncer (otherwise incoming pulse is ignored)*
- When the debouncer is bypassed then the pulse width of external capture signal has to be longer than one timer clock period (otherwise an invalid value could be loaded to the capture register)*
- These two conditions need to be fulfilled when the debouncer is enabled and external input capture event need to be captured.*

OUTPUT COMPARE

The output compare function allows generating a multitude of different output signal waveforms. PWM, variable or fix frequencies, RTZ (Return To Zero clocks), RTO (Return To One clocks) to name just a few. It may also be used to encode serial protocols i.e Manchester encoding. The compare function is enabled by setting bit **TimXEnPWM** in register **RegTimXCfg** to '1'.

The compare function uses the **PWMX** signal of the timer.

At system reset **PWMX** is forced low.

PWMX will maintain its last status when the corresponding **TimXEnPWM = '0'**.

Whenever the timer reaches **RegTimXFull** or **RegTimXCmpVal** an action may be performed on **PWMX**. The action is defined by **TimXCmpFullAct** when it reaches **RegTimXFull** and by **TimXCmpValAct** when it reaches **RegTimXCmpVal** as defined in tables below: (**TimXCmpFullAct** action has a priority).

Successive comparisons may be made.

Output compare usually is used in Auto-Reload mode (free running counter).

Figure 20, Output Compare Description

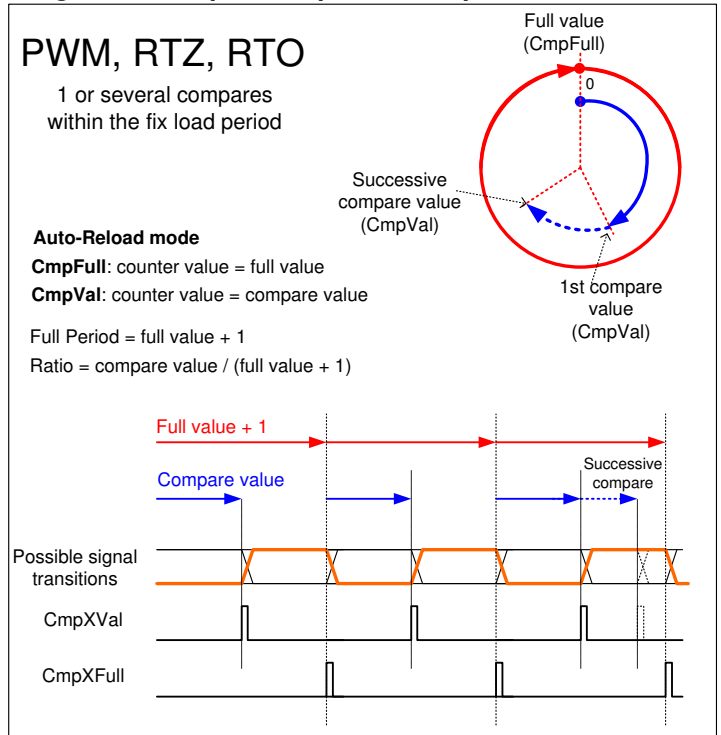

TimXCmpValAct	Action when timerX reaches RegTimXCmpVal
00	No action on PWMX
01	Force 0 on PWMX
10	Force 1 on PWMX
11	Toggle PWMX

TimXCmpFullAct	Action when timerX reaches RegTimXFull
00	No action on PWMX
01	Force 0 on PWMX
10	Force 1 on PWMX
11	Toggle PWMX

Figure 21, Output Compare Architecture

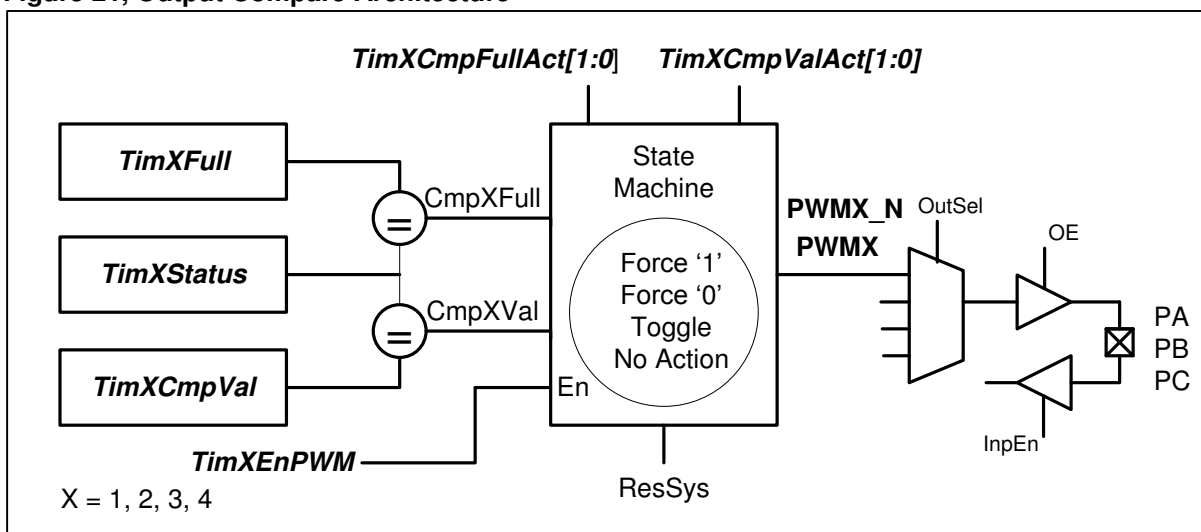

17.7 OUTPUT COMPARE - *PWMX* SIGNAL PORT MAPPING

Mapping of the timers PWM signal to the port A, B and C terminals.

The port mapping is made in such a way that usually one has the *PWMX* and its complementary output *PWMX_N* available. Using the differential output voltages between *PWMX* and *PWMX_N* the output drive energy increases by a factor 4.

Figure 22, *PWMX* complementary outputs

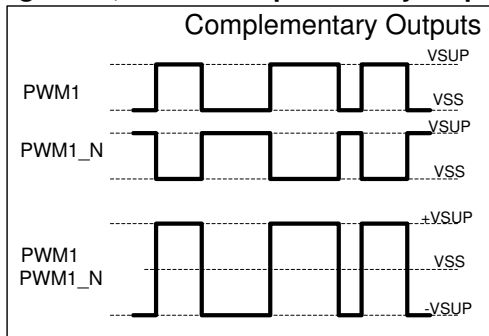

The corresponding port setup must be made to allow the *PWMX* and *PWMX_N* signal to output on the mapped port terminal.

PortA	PA0	PA1	PA2	PA3	PA4	PA5	PA6	PA7
PWM1		X	X					
PWM_1N							X	
PWM2						X		
PWM_2N	X	X						
PWM3						X		
PWM_3N	X							
PWM4						X		
PWM_4N	X							

PortC	PC0	PC1	PC2	PC3	PC4	PC5	PC6	PC7
PWM1								X
PWM_1N		X	X				X	
PWM2								
PWM_2N								
PWM3								
PWM_3N		X						X
PWM4								
PWM_4N		X						

PortB	PB0	PB1	PB2	PB3	PB4	PB5	PB6	PB7
PWM1			X		X			X
PWM_1N				X			X	
PWM2	X					X		
PWM_2N		X						
PWM3	X		X		X	X		X
PWM_3N		X		X			X	
PWM4	X					X		
PWM_4N		X						

17.8 TIMER INTERRUPTS

Timer interrupts may be generated on hardware capture events, when the timer reaches the compare value and when the timer reaches the full value.

The timer interrupt generation is totally independent of the different timer mode settings.

Interrupt generation when:

- The CmpFull interrupt is only generated when **TimXIntSel** in register **RegTimXCfg** is '0', and the counter reaches the **TimXFull** value
- The CmpVal interrupt is only generated when **TimXIntSel** in register **RegTimXCfg** is '1', and the counter reaches the **TimXCmpVal** value
- The capture interrupt is always generated if a valid hardware input capture event is applied to the selected input source.

Figure 23, Timer Interrupt structure

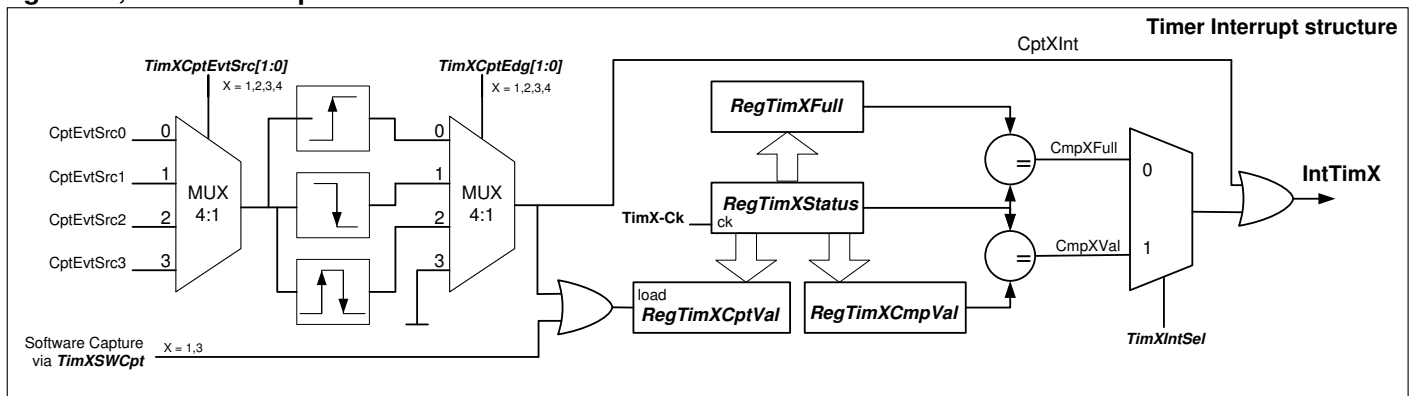

17.9 TIMER REGISTERS

0x003B		RegTimersCfg			Timers Configuration
Bits	Name	Type	ResVal	ResSrc	Description
7	Tim12Chain	RW	0	ResSys	Chain Timer1 & Timer2 into one 16bit Timer
6	Tim34Chain	RW	0	ResSys	Chain Timer3 & Timer4 into one 16bit Timer
5	Tim1AR	RW	0	ResSys	Autoreload mode of Timer1
4	Tim2AR	RW	0	ResSys	Autoreload mode of Timer2
3	Tim3AR	RW	0	ResSys	Autoreload mode of Timer3
2	Tim4AR	RW	0	ResSys	Autoreload mode of Timer4
1	Tim1SWCpt	OS	0	ResSys	Timer1/12 SW event for Capture
0	Tim3SWCpt	OS	0	ResSys	Timer3/34 SW event for Capture

0x003C		RegTimersStart			Timers Start Event Configuration
Bits	Name	Type	ResVal	ResSrc	Description
7	Tim1SWStart	STS	0	ResSys	Start/Run Timer1 by SW
6	Tim1Pulse	RW	0	ResSys	1-Start-Stop Timer1 by Event, 0-Enable/Run by active level
5	Tim2SWStart	STS	0	ResSys	Start/Run Timer2 by SW
4	Tim2Pulse	RW	0	ResSys	1-Start-Stop Timer2 by Event, 0-Enable/Run by active level
3	Tim3SWStart	STS	0	ResSys	Start/Run Timer3 by SW
2	Tim3Pulse	RW	0	ResSys	1-Start-Stop Timer3 by Event, 0-Enable/Run by active level
1	Tim4SWStart	STS	0	ResSys	Start/Run Timer4 by SW
0	Tim4Pulse	RW	0	ResSys	1-Start-Stop Timer4 by Event, 0-Enable/Run by active level

0x003D		RegTim1Cfg			Timer1 Configuration
Bits	Name	Type	ResVal	ResSrc	Description
7	Tim1EnPWM	RW	0	ResSys	Enable PWM function of Timer1
6	Tim1IntSel	RW	0	ResSys	0-Int. on Full value, 1-Int. on Compare value
5:3	Tim1SelStart	RW	'000'	ResSys	Start source selection
2:0	Tim1SelClk	RW	'000'	ResSys	Clock source selection

0x003E		RegTim1CptCmpCfg			Timer1 Compare & Capture functions configuration
Bits	Name	Type	ResVal	ResSrc	Description
7:6	Tim1CptEdg	RW	'00'	ResSys	Capture event Edge Selection
5:4	Tim1CptEvtSrc	RW	'00'	ResSys	Capture Event External Source Selection.
3:2	Tim1CmpFullAct	RW	'00'	ResSys	Action selection on PWM1 when status reaches Load value
1:0	Tim1CmpValAct	RW	'00'	ResSys	Action selection on PWM1 when status reaches Compare value

0x003F		RegTim1Status			Timer1 Status
Bits	Name	Type	ResVal	ResSrc	Description
7:0	Tim1Status	RO	0x00	ResSys	Timer1 Status

0x0040		RegTim1Full			Timer1 Full / End Of Count value
Bits	Name	Type	ResVal	ResSrc	Description
7:0	Tim1Full	RW	0xFF	ResSys	Timer1 Full / End Of Count value

0x0041		RegTim1CmpVal			Timer1 Compare Value
Bits	Name	Type	ResVal	ResSrc	Description
7:0	Tim1CmpVal	RW	0x00	ResSys	Timer1 Compare Value

0x0042		RegTim1CptVal			Timer1 Captured Value
Bits	Name	Type	ResVal	ResSrc	Description
7:0	Tim1CptVal	RO	0x00	ResSys	Timer1 Captured Value

0x0043		RegTim2Cfg			Timer2 Configuration
Bits	Name	Type	ResVal	ResSrc	Description
7	Tim2EnPWM	RW	0	ResSys	Enable PWM function of Timer2
6	Tim2IntSel	RW	0	ResSys	0-Int. on Full value, 1-Int. on Compare value
5:3	Tim2SelStart	RW	'000'	ResSys	Start source selection
2:0	Tim2SelClk	RW	'000'	ResSys	Clock source selection

0x0044		RegTim2CptCmpCfg			Timer2 Compare & Capture functions configuration
Bits	Name	Type	ResVal	ResSrc	Description
7:6	Tim2CptEdg	RW	'00'	ResSys	Capture event Edge Selection
5:4	Tim2CptEvtSrc	RW	'00'	ResSys	Capture Event External Source Selection.
3:2	Tim2CmpFullAct	RW	'00'	ResSys	Action selection on PWM2 when status reaches Load value
1:0	Tim2CmpValAct	RW	'00'	ResSys	Action selection on PWM2 when status reaches Compare value

0x0045		RegTim2Status			Timer2 Status
Bits	Name	Type	ResVal	ResSrc	Description
7:0	Tim2Status	RO	0x00	ResSys	Timer2 Status

0x0046		RegTim2Full			Timer2 Full / End Of Count value
Bits	Name	Type	ResVal	ResSrc	Description
7:0	Tim2Full	RW	0xFF	ResSys	Timer2 Full / End Of Count value



0x0047		RegTim2CmpVal			Timer2 Compare Value
Bits	Name	Type	ResVal	ResSrc	Description
7:0	Tim2CmpVal	RW	0x00	ResSys	Timer2 Compare Value

0x0048		RegTim2CptVal			Timer2 Captured Value
Bits	Name	Type	ResVal	ResSrc	Description
7:0	Tim2CptVal	RO	0x00	ResSys	Timer2 Captured Value

0x0049		RegTim3Cfg			Timer3 Configuration
Bits	Name	Type	ResVal	ResSrc	Description
7	Tim3EnPWM	RW	0	ResSys	Enable PWM function of Timer3
6	Tim3IntSel	RW	0	ResSys	0-Int. on Full value, 1-Int. on Compare value
5:3	Tim3SelStart	RW	'000'	ResSys	Start source selection
2:0	Tim3SelClk	RW	'000'	ResSys	Clock source selection

0x004A		RegTim3CptCmpCfg			Timer3 Compare & Capture functions configuration
Bits	Name	Type	ResVal	ResSrc	Description
7:6	Tim3CptEdg	RW	'00'	ResSys	Capture event Edge Selection
5:4	Tim3CptEvtSrc	RW	'00'	ResSys	Capture Event External Source Selection.
3:2	Tim3CmpFullAct	RW	'00'	ResSys	Action selection on PWM3 when status reaches Load value
1:0	Tim3CmpValAct	RW	'00'	ResSys	Action selection on PWM3 when status reaches Compare value

0x004B		RegTim3Status			Timer3 Status
Bits	Name	Type	ResVal	ResSrc	Description
7:0	Tim3Status	RO	0x00	ResSys	Timer3 Status

0x004C		RegTim3Full			Timer3 Full / End Of Count value
Bits	Name	Type	ResVal	ResSrc	Description
7:0	Tim3Full	RW	0xFF	ResSys	Timer3 Full / End Of Count value

0x004D		RegTim3CmpVal			Timer3 Compare Value
Bits	Name	Type	ResVal	ResSrc	Description
7:0	Tim3CmpVal	RW	0x00	ResSys	Timer3 Compare Value

0x004E		RegTim3CptVal			Timer3 Captured Value
Bits	Name	Type	ResVal	ResSrc	Description
7:0	Tim3CptVal	RO	0x00	ResSys	Timer3 Captured Value

0x004F		RegTim4Cfg			Timer4 Configuration
Bits	Name	Type	ResVal	ResSrc	Description
7	Tim4EnPWM	RW	0	ResSys	Enable PWM function of Timer4
6	Tim4IntSel	RW	0	ResSys	0-Int. on Full value, 1-Int. on Compare value
5:3	Tim4SelStart	RW	'000'	ResSys	Start source selection
2:0	Tim4SelClk	RW	'000'	ResSys	Clock source selection

0x0050		RegTim4CptCmpCfg			Timer4 Compare & Capture functions configuration
Bits	Name	Type	ResVal	ResSrc	Description
7:6	Tim4CptEdg	RW	'00'	ResSys	Capture event Edge Selection
5:4	Tim4CptEvtSrc	RW	'00'	ResSys	Capture Event External Source Selection.
3:2	Tim4CmpFullAct	RW	'00'	ResSys	Action selection on PWM4 when status reaches Load value
1:0	Tim4CmpValAct	RW	'00'	ResSys	Action selection on PWM4 when status reaches Compare value



0x0051		RegTim4Status			Timer4 Status
Bits	Name	Type	ResVal	ResSrc	Description
7:0	Tim4Status	RO	0x00	ResSys	Timer4 Status

0x0052		RegTim4Full			Timer4 Full / End Of Count value
Bits	Name	Type	ResVal	ResSrc	Description
7:0	Tim4Full	RW	0xFF	ResSys	Timer4 Full / End Of Count value

0x0053		RegTim4CmpVal			Timer4 Compare Value
Bits	Name	Type	ResVal	ResSrc	Description
7:0	Tim4CmpVal	RW	0x00	ResSys	Timer4 Compare Value

0x0054		RegTim4CptVal			Timer4 Captured Value
Bits	Name	Type	ResVal	ResSrc	Description
7:0	Tim4CptVal	RO	0x00	ResSys	Timer4 Captured Value

18. SPI – SERIAL INTERFACE

The circuit contains a synchronous 3-wire (SDI, SDOU and SCLK) master and slave serial interface. Its ports are mapped on different PA, PB and PC IO terminals.

- SCLK: Serial Clock Input/ Output: Input in Slave mode, Output in Master mode
- SDIN: Serial Interface Data Input. Input in Master and Slave mode
- SDOU: Serial Interface Data Output. Output in Master and Slave mode

The serial interface always transmits or receives 8-bit packages at a time, followed by an interrupt request allowing the CPU to treat the data.

An Interrupt **IntSPISStart** is generated at transmission start and an **IntSPISStop** at the end of the transmission. An Event **EvtSPI** is generated at transmission start and at the end of the transmission.

The interface may also be used to generate a fix datastream output by using the Auto-Start mode.

The internal shift register clock edge is user selectable; the interface may run on RTZ (Return To Zero) or RTO (Return to One) type of clocks. SIN can be sampled on different edge SOUT is driven setting register **SPICompMode** at 1.

The full SPI setup shall be configured before enabling the SPI (**SPIEn**='1'). Once enabled the configuration must not be changes anymore.

While **SPIEn** is '0', **SPISStart** is reset. **SPIEn** must be written '1' before **SPISStart** is set.

The transmission may start as soon as **SPISStart** is set '1'. Always make first full SPI setup and only at the end set the bit **SPISStart** to '1' to begin the data exchange.

The register **RegSPIDOut** and **RegSPIDIn** act as a buffer for outgoing and incoming data. The **RegSPIDOut** must be written before the transmission starts. The **RegSPIDIn** will be updated after the 8th active clock with the actual received input data.

The transmission direction is configurable with bit **SPIMSB1st**. Set to '1' the first transmission bit is the MSB bit , if set '0' then it is the LSB bit.

Figure 24, Serial Interface Architecture

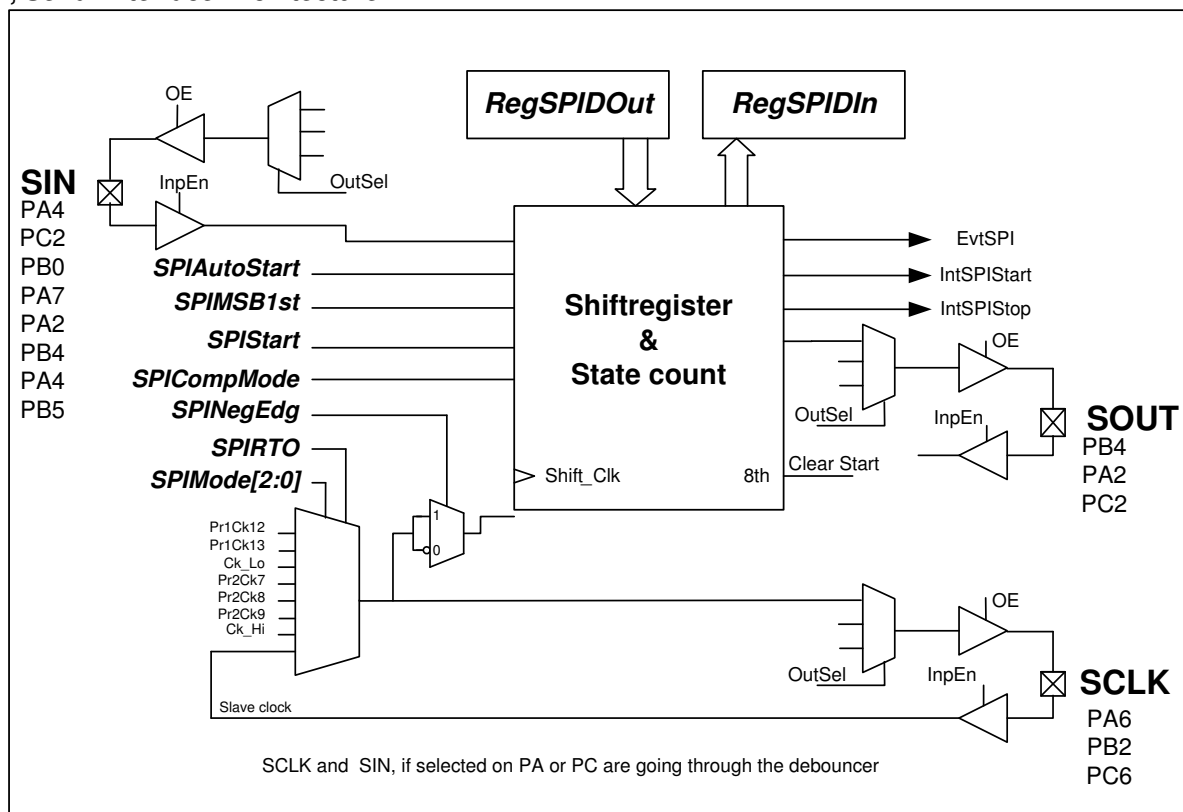

18.1 SCLK - SPI MASTER/ SLAVE MODE AND CLOCK SELECTION

Master and Slave mode as well as master mode clock selection are done in register **RegSPICfg1** bits **SPIMode**. In Slave mode the serial input clock is coming from PA6, PB2 or PC6 input. The selection depends on **SPISelSCLK** bits in register **RegSPICfg2** and the corresponding port input enable bit must be '1'.

SCLK Frequency selection

SPIMode	SCLK base clock
SLAVE Mode SCLK from port inputs	
000	from PA6, PB2 PC6
Master mode, Prescaler 2 clocks	
001	Ck_Hi
010	Pr2Ck9
011	Pr2Ck8
100	Pr2Ck7
Master mode, Prescaler 1 clocks	
101	Ck_Lo
110	Pr1Ck13
111	Pr1Ck12

SCLK Slave mode input selection





Input terminal	Input condition	SPIMode[2:0]
<i>Slave Mode</i>		
PA6	SPISelSCLK='00' PA6InpE='1'	000 (slave)
PB2	SPISelSCLK='01' PB2InpE='1'	000 (slave)
PC6	SPISelSCLK='10' PC6InpE='1'	000 (slave)
PA6	SPISelSCLK='11' PA6InpE='1'	000 (slave)

SCLK Master mode output selection

Output terminal	Output condition
<i>Master Mode</i>	
PA6	PA6OutSel[1:0]='01' PA6OE='1'
PB2	PB2OutSel[1:0]='01' PB2OE='1'
PC6	PC6OutSel[1:0]='01' PC6OE='1'

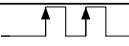
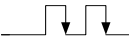
The used PA, PB and PC IO port terminals must be set up for SPI before **SPIStart** is set high.

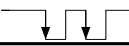
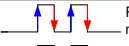
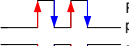
Following table shows the different SCLK clock possibilities RTZ and RTO with the internal shift clock dependencies.

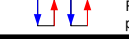
SPICompMode	SPIRTO	SPINegEdg	SCLK pulse	SCLK IDLE value	SIN sampling	SOUT shifting	Clock type	Example on SCLK
0	0	0	High Pulse	High	Pos edge	Pos edge	RTZ	 RTZ, pos edge
0	0	1	High Pulse	High	Neg edge	Neg edge	RTZ	 RTZ, neg edge
0	1	0	Low pulse	Low	Pos edge	Pos edge	RTO	 RTO, pos edge
0	1	1	Low pulse	Low	Neg edge	Neg edge	RTO	 RTO, neg edge
1	0	0	High Pulse	High	Neg edge	Pos edge	RTZ	 RTZ, pos edge SOUT neg edge SIN
1	0	1	High Pulse	High	Pos edge	Neg edge	RTZ	 RTZ, neg edge SOUT pos edge SIN
1	1	0	Low pulse	Low	Neg edge	Pos edge	RTO	 RTO, pos edge SOUT neg edge SIN
1	1	1	Low pulse	Low	Pos edge	Neg edge	RTO	 RTO, neg edge SOUT pos edge SIN

SPIRTO defines a RTZ clock type if set to '1' or RTO clock type if set to '0'

SPINegEdg defines the internal shift register shift clock edge, set to '1' shift takes place on the negative SCLK clock edge. Set to '0', the shift will take on the positive SCLK clock edge. Both bits are placed in register **RegSPICfg1**.

When **SPICompMode** = 1 SIN and SOUT are working on opposite phase. It makes the **u6819FX-B300** SPI compatible with MISO/MOSI standard protocols.

18.2 SIN PORT MAPPING

The serial data input may come from PA4, PC2, PB0, PA7, PA2, PB4, PA4, PB5. On PA4, PC2, PA7, PA2 and PA4 the debounced signal (i.e **PADeb2**) is used as serial data input, from PB0, PB4 and PB5 it is directly the pad input while the input enable is high.

The data shifted in through SIN terminal will be stored into the buffer register **RegSPIDIn** after the 8th shift clock.

MSB or LSB first on the SIN reception is selected with bit **SPIMSB1st**.

Input terminal	Input condition
PA4	SPISeSIN[1:0]='000' PA4InpE='1'
PC2	SPISeSIN[1:0]='001' PC2InpE='1'
PB0	SPISeSIN[1:0]='010' PB0InpE='1'
PA7	SPISeSIN[1:0]='011' PA7InpE='1'
PA2	SPISeSIN[1:0]='100' PA2InpE='1'
PB4	SPISeSIN[1:0]='101' PB4InpE='1'
PA4	SPISeSIN[1:0]='110' PA4InpE='1'
PB5	SPISeSIN[1:0]='111' PB5InpE='1'

18.3 SOUT PORT MAPPING

The serial data output is mapped on PB4, PA2 or PC2. The corresponding port output must be setup by the corresponding port output selection bits as SDOOUT output with its output enable high.

The data to be shift out must be written into the output buffer register **RegSPIDOut** before the transmission is started.

MSB or LSB first on the SOUT transmission is selected with bit **SPIMSB1st**.

Output terminal	Output condition
PB4	PB4OutSel[1:0]='01' PB4OE='1'
PA2	PA2OutSel[1:0]='01' PA2OE='1'
PA7	PA7OutSel[1:0]='01' PA7OE='1'
PC2	PC2OutSel[1:0]='01' PC2OE='1'

18.4 SPI START – STOP

In master mode writing *bit* **SPIStart**='1' will launch the transmission when it goes high and SPIEn='1'. After the 8th active SCLK clock edge the **SPIStart** will be forced low. SPIStart can be used as a status register to monitor ongoing transmission.

Writing '0' to **SPIStart** during the transmission will stop the SPI. In this case the content of **RegSPIDIn** is not guaranteed.

Note:

Chipselect handling for master mode shall be handled by the user software on any user defined PA, PB or PC output.

In slave mode, the transmission starts as soon as the 1st clock pulse occurs after **SPIStart** was written '1'.

Note:

In slave mode, for the synchronization, the user can generate a flag by software on a terminal to indicate to the master that the SPI is ready.

18.5 AUTO-START

With Auto-Start one can transmit several 8-bit packages without any delay between the packages. As such it allows generating a fix datastream output. The bit **SPIAutoStart** needs to be high to allow Auto-Start

For Auto-Start to take place one needs to write the next package data into the **RegSPIDOut** during the ongoing transmission. The SPIStart will in this case stay high after the 8th active clock edge and the new transmission will follow immediately after.

All interrupts **IntSPIStart**, **IntSPIStop** and the event **EvtSPI** are generated also in Auto-Start mode.

If the bit **SPIAutoStart** is at '0', the auto start mode is disabled, writing to **RegSPIDOut** during the transmission will have no effect.

18.6 RTZ POSITIVE EDGE TRANSMISSION SPICOMPMODE = 0

With RTZ (Return To Zero) positive edge transmission the SCLK clock is low between successive transmissions.

The SOUT data will change on the on the rising SCLK clock edge. The 1st bit of data SPIDout data will be shift out on the rising edge of the 1st SCLK clock and the last on the 8th SCLK clock rising edge.

The SIN data must be stable at the SCLK rising edge to be properly shifted in, the buffer **RegSPIDIn** will be updated with the received data at the rising edge of the 8th shift clock.

An interrupt request **IntSPIStart** and an event **EvtSPI** are generated by the rising edge of the 1st SCLK clock. An interrupt request **IntSPIStop** and an event **EvtSPI** are generated by the rising edge of the 8th SCLK clock.

Figure 25, RTZ Positive edge transmission

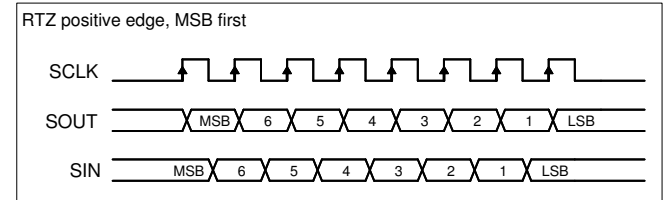

18.7 RTO POSITIVE EDGE TRANSMISSION SPICOMPMODE = 0

With RTO (Return To One) positive edge transmission the SCLK clock is high between successive transmissions.

The 1st bit contains in **RegSPIDOut** will be on SOUT before the first transmission if SPIEn = '1' or on the falling edge of the 7th SCLK pulse after the transmission. The 2nd bit contains in **RegSPIDOut** will be shifted out on the rising edge of the 1st SCLK pulse. The 8th bit contained in **RegSPIDOut** will be shifted out on the rising edge of the 7th SCLK pulse.

SIN data must be stable on the rising edge of SCLK to be properly aquired and shifted.

The buffer register **RegSPIDIn** will be updated with the received data on the rising edge of the 8th SCLK clock. An interrupt request **IntSPIStart** and an event **EvtSPI** are generated by the rising edge of the 1st SCLK clock. An interrupt request **IntSPIStop** and an event **EvtSPI** are generated by the rising edge of the 8th SCLK clock.

Figure 26, RTO Positive edge transmission

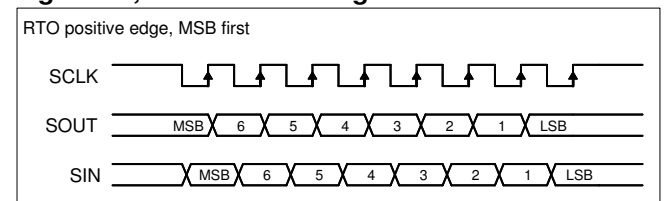

18.8 RTZ NEGATIVE EDGE TRANSMISSION SPICOMPMODE = 0

With RTZ (Return To Zero) negative edge transmission the SCLK clock is low between successive transmissions.

The 1st bit contains in **RegSPIDOut** will be on SOUT before the first transmission if SPIEn = '1' or on the falling edge of the 7th SCLK pulse after the transmission. The 2nd bit contains in **RegSPIDOut** will be shifted out on the falling edge of the 1st SCLK pulse. The 8th bit contains in **RegSPIDOut** will be shifted out on the falling edge of the 7th SCLK pulse.

SIN data must be stable on the falling of SCLK to be properly aquired and shifted.

The buffer register **RegSPIDIn** will be updated with the received data on the falling edge of the 8th SCLK clock. An interrupt request **IntSPIStart** and an event **EvtSPI** are generated by the falling edge of the 1st SCLK clock. An interrupt request **IntSPIStop** and an event **EvtSPI** are generated by the falling edge of the 8th SCLK clock.

Figure 27, RTZ Negative edge transmission

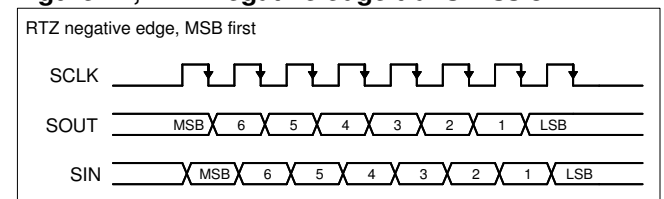

18.9 RTO NEGATIVE EDGE TRANSMISSION SPICOMPmode = WITH RTO (RETURN TO ONE) NEGATIVE EDGE TRANSMISSION THE SCLK CLOCK IS HIGH BETWEEN SUCCESSIVE TRANSMISSIONS.

The SOUT data will change on the on the falling SCLK clock edge. The 1st bit of data SPIDout data will be shift out on the falling edge of the 1st SCLK clock and the last on the 8th SCLK clock falling edge.

The SIN data must be stable at the SCLK falling edge to be properly shifted in, the buffer **RegSPIDIn** will be updated with the received data at the falling edge of the 8th shift clock.

An interrupt request **IntSPIStart** and an event **EvtSPI** are generated by the falling edge of the 1st SCLK clock. An interrupt request **IntSPIStop** and an event **EvtSPI** are generated by the falling edge of the 8th SCLK clock.

Figure 28, RTO Negative edge transmission

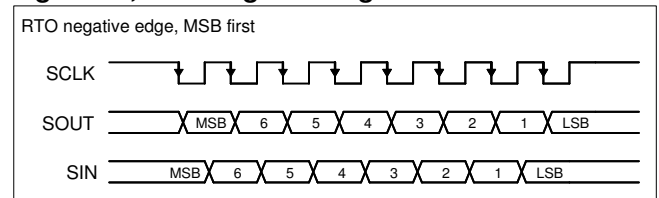

18.10 RTZ POSITIVE EDGE TRANSMISSION SPICOMPmode = 1 WITH RTZ (RETURN TO ZERO) POSITIVE EDGE TRANSMISSION THE SCLK CLOCK IS LOW BETWEEN SUCCESSIVE TRANSMISSIONS.

The SOUT data will change on the on the rising SCLK clock edge. The 1st bit of data SPIDout data will be shift out on the rising edge of the 1st SCLK clock and the last on the 8th SCLK clock rising edge.

The SIN data must be stable at the SCLK falling edge to be properly shifted in, the buffer **RegSPIDIn** will be updated with the received data at the falling edge of the 8th shift clock.

An interrupt request **IntSPIStart** and an event **EvtSPI** are generated by the rising edge of the 1st SCLK clock. An interrupt request **IntSPIStop** and an event **EvtSPI** are generated by the rising edge of the 8th SCLK clock.

Figure 29, RTZ Positive edge transmission

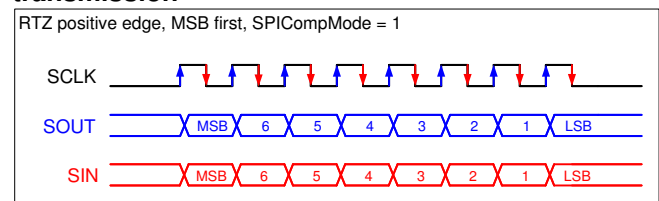

18.11 RTO POSITIVE EDGE TRANSMISSION SPICOMPmode = 1 WITH RTO (RETURN TO ONE) POSITIVE EDGE TRANSMISSION THE SCLK CLOCK IS HIGH BETWEEN SUCCESSIVE TRANSMISSIONS.

The 1st bit contains in **RegSPIDOut** will be on SOUT before the first transmission if SPIEn = '1' or on the falling edge of the 7th SCLK pulse after the transmission. The 2nd bit contains in **RegSPIDOut** will be shifted out on the rising edge of the 1st SCLK pulse. The 8th bit contained in **RegSPIDOut** will be shifted out on the rising edge of the 7th SCLK pulse.

SIN data must be stable on the falling edge of SCLK to be properly aquired and shifted.

The buffer register **RegSPIDIn** will be updated with the received data on the falling edge of the 8th SCLK clock.

An interrupt request **IntSPIStart** and an event **EvtSPI** are generated by the rising edge of the 1st SCLK clock. An interrupt request **IntSPIStop** and an event **EvtSPI** are generated by the rising edge of the 8th SCLK clock.

Figure 30, RTO Positive edge transmission

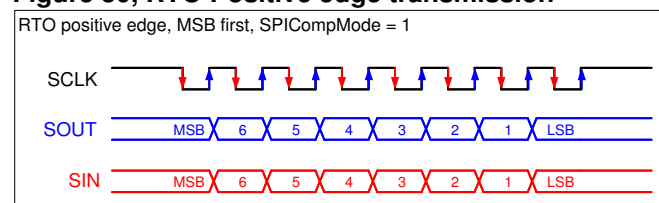

18.12 RTZ NEGATIVE EDGE TRANSMISSION SPICOMPMODE = 1 WITH RTZ (RETURN TO ZERO) NEGATIVE EDGE TRANSMISSION THE SCLK CLOCK IS LOW BETWEEN SUCCESSIVE TRANSMISSIONS. THE 1ST BIT CONTAINS IN REGSPIDOUT WILL BE ON SOUT BEFORE THE FIRST TRANSMISSION IF SPIEN = '1' OR ON THE FALLING EDGE OF THE 7TH SCLK PULSE AFTER THE TRANSMISSION. THE 2ND BIT CONTAINS IN REGSPIDOUT WILL BE SHIFTED OUT ON THE FALLING EDGE OF THE 1ST SCLK PULSE.

The 8th bit contains in **RegSPIDOut** will be shifted out on the falling edge of the 7th SCLK pulse.

SIN data must be stable on the rising of SCLK to be properly acquired and shifted.

The buffer register **RegSPIDIn** will be updated with the received data on the rising edge of the 8th SCLK clock. An interrupt request **IntSPISStart** and an event **EvtSPI** are generated by the falling edge of the 1st SCLK clock. An interrupt request **IntSPISStop** and an event **EvtSPI** are generated by the falling edge of the 8th SCLK clock.

Figure 31, RTZ Negative edge transmission

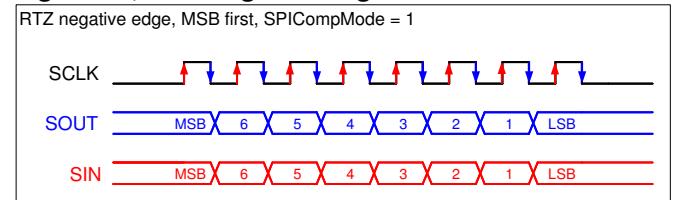

18.13 RTO NEGATIVE EDGE TRANSMISSION SPICOMPMODE = 1 WITH RTO (RETURN TO ONE) NEGATIVE EDGE TRANSMISSION THE SCLK CLOCK IS HIGH BETWEEN SUCCESSIVE TRANSMISSIONS. THE SOUT DATA WILL CHANGE ON THE ON THE FALLING SCLK CLOCK EDGE. THE 1ST BIT OF DATA SPIDOUT DATA WILL BE SHIFT OUT ON THE FALLING EDGE OF THE 1ST SCLK CLOCK AND THE LAST ON THE 8TH SCLK CLOCK FALLING EDGE.

The SIN data must be stable at the SCLK rising edge to be properly shifted in, the buffer **RegSPIDIn** will be updated with the received data at the rising edge of the 8th shift clock.

An interrupt request **IntSPISStart** and an event **EvtSPI** are generated by the falling edge of the 1st SCLK clock. An interrupt request **IntSPISStop** and an event **EvtSPI** are generated by the falling edge of the 8th SCLK clock.

Figure 32, RTO Negative edge transmission

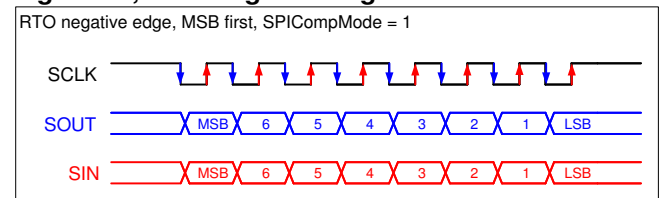

Note:

The SPI signals has the following setup and hold time parameters:

Conditions: VSUP = 2.0 V, Temp = -40 °C to 85 °C, external Cload on pad = 30 pF

SCLK frequency, port A and C	fSPIAC	max 8 MHz
SCLK frequency, port B	fSPIB	max 10 MHz
SIN setup time, slave mode	tsUSINS	min 6 ns
SIN setup time, master mode	tsUSINM	min 29 ns (port A, C), min 25ns (port B)
SIN hold time	thdSIN	min 5 ns
SOUT delay_time	TdelsOUT	max 32ns (port A, C), max 26ns (port B)

Above values are not verified on production testing.

18.14 SPI REGISTERS

0x007A		RegSPICfg1			SPI Configuration - 1
Bits	Name	Type	ResVal	ResSrc	Description
7	SPIEn	RW	0	ResSys	SPI Enable
6:4	SPIMode	RW	'000'	ResSys	SPI Mode and SClk selection
3	SPINegEdg	RW	0	ResSys	SPI active on Negative Edge
2	SPIRTO	RW	0	ResSys	SPI RTO (Return To One)
1	SPIMSB1st	RW	1	ResSys	SPI MSB First
0	SPIAutoStart	RW	1	ResSys	SPI Auto Start Enabled

0x007B		RegSPICfg2			SPI Configuration - 2
Bits	Name	Type	ResVal	ResSrc	Description
7:6	SPISelSClk	RW	'00'	ResSys	SPI SClk Selection
5:3	SPISelSIn	RW	'00'	ResSys	SPI SIn Selection
2:1	-	NI	-	-	Not implemented
0	SPICompMode	RW	'0'	ResSys	SPI change phase of SIN versus SOUT

0x007C		RegSPIStart			SPI Start
Bits	Name	Type	ResVal	ResSrc	Description
7	SPIStart	STS	0	ResSys	SPI Start
6:0	-	NI	-	-	Not implemented

0x007D		RegSPIDIn			SPI Received Data
Bits	Name	Type	ResVal	ResSrc	Description
7:0	SPIDIn	RO	0x00	ResSys	SPI Received Data

0x007E		RegSPIDOut			SPI Data to Transmit
Bits	Name	Type	ResVal	ResSrc	Description
7:0	SPIDOut	RW	0x00	ResSys	SPI Data to Transmit

19. WATCHDOG

The function of the watchdog is to generate a reset **ResSys** and **ResAna** by asserting the **ResWD** signal if during a given timeout period the CPU did not clear the WD counter (**WDClear**).

It therefore uses a 16-bits counter that counts down from start (**RegWDLdValM** (MSB) and **RegWDLdValL** (LSB)) value down to 0x0000. The counter uses directly the RC 8 KHz clock. This RC clock is always enabled together with the watchdog. Refer also to chapter Oscillator and Clock selection for the RC 8 KHz clock.

Figure 33, Watchdog architecture

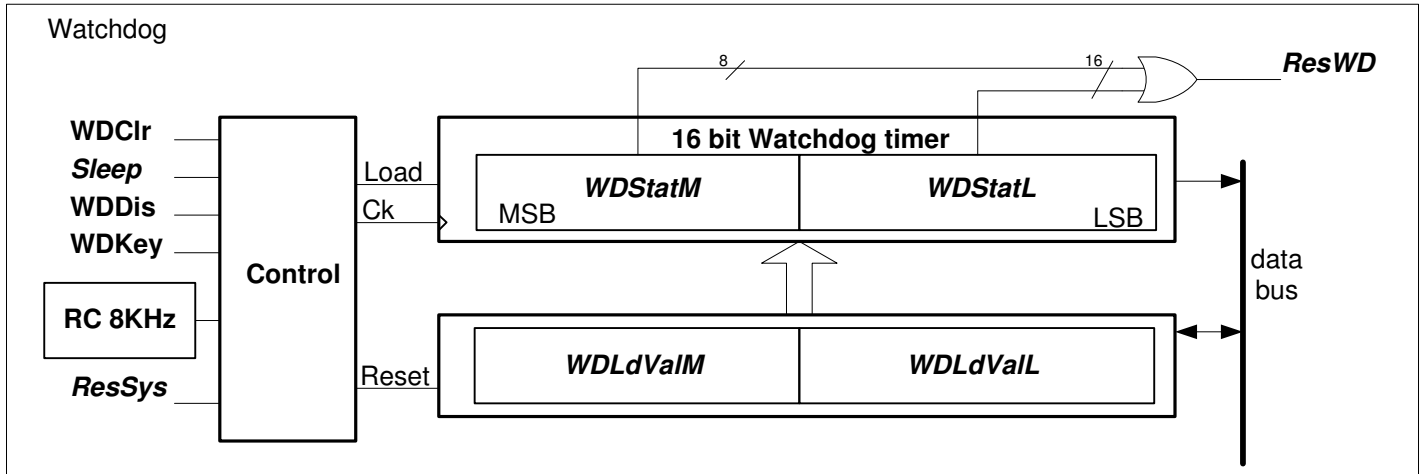

19.1 WATCHDOG CLEAR

The software writes '1' to the one shot register **RegWDCfg** bit **WDClear** to avoid watchdog reset, at the same time the counter will reload the initial start value given by registers **RegWDLdValM** and **RegWDLdValL**.

If the counter reaches 0x0000 and **WDDis** = '0' then signal WatchDog timeout **ResWD** will be asserted.

The watchdog counter status can be read in registers **RegWDStatM** (MSB) and **RegWDStatL** (LSB).

Note:

Due to asynchronous domain crossing the SW may read the status during its change i.e. a nonsense value. Only two consecutive reads of the same stable value can assure about its correctness if the WD is running.

The occurrence of a watchdog reset can be read in the rest flag register **RegResFlag** bit **ResFlagWD**.

The timeout, based on the 8 KHz RC oscillator can be set as high as 8.2s (load value of 0xFFFF) with a LSB value of typical 125us. The default load value of 0x8000 corresponds to 4.1 secondes.

In sleep mode watchdog is always disable.

19.2 WATCHDOG DISABLING

If the register **RegWDKey** contains the value (*watch_dog_key* = 0xCA) it becomes possible to disable the WD by writing '1' to register **RegWDCfg** bit **WDDis**.

If **RegWDKey** contains the watchdog a value <> 0xCA it will be impossible to disable the WD, register **RegWDCfg** bit **WDDis** will be forced low.

The WatchDog counter is disabled in Sleep mode and if **RegWDCfg.WDDis** = '1' while *watch_dog_key* is valid.

The counter will reload the start value when started and/or re-enabled.

Note:

The WatchDog Clear may take up to 3 WD clocks (~375 us).

The WatchDog Start-up may take up to 4 WD clocks (~500 us).

*Any change in **RegWdLdValM** or **RegWdLdValL** during this time will affect the WD Counter value.*

19.3 WATCHDOG REGISTERS

0x0006		RegResFlg			Reset Flags
Bits	Name	Type	ResVal	ResSrc	Description
7	ResFlgPA	ResFlg	0	POR	Flag Reset from Port-A
6	ResFlgWD	ResFlg	0	POR	Flag Reset from WatchDog
5	ResFlgBO	ResFlg	0	POR	Flag Reset from Brown-Out
4	ResFlgGasp	ResFlg	0	POR	Flag Reset from GASP
3	ResFlgBE	ResFlg	0	POR	Flag Reset from CoolRisc Bus-Error
0	-	NI	0		

0x006D		RegWDCfg			WatchDog Configuration
Bits	Name	Type	ResVal	ResSrc	Description
7	WDDis	RW	0	ResSys	WatchDog Disable
0	WDClear	OS	0		WatchDog Clear - Restart Counting

0x006E		RegWDKey			WatchDog Key (0xCA) for disabling
Bits	Name	Type	ResVal	ResSrc	Description
7:0	WDKey	RW	0x00	ResSys	WatchDog Key (0xCA) for disabling

0x006F		RegWDLdValL			WatchDog Start/Load value LSB
Bits	Name	Type	ResVal	ResSrc	Description
7:0	WDLdValL	RW	0x00	ResSys	WatchDog Start/Load value LSB

0x0070		RegWDLdValM			WatchDog Start/Load value MSB
Bits	Name	Type	ResVal	ResSrc	Description
7:0	WDLdValM	RW	0x80	ResSys	WatchDog Start/Load value MSB

0x0071		RegWDStatL			WatchDog Status LSB
Bits	Name	Type	ResVal	ResSrc	Description
7:0	WDStatL	RO	0x00	ResSys	WatchDog Status LSB

0x0072		RegWDStatM			WatchDog Status MSB
Bits	Name	Type	ResVal	ResSrc	Description
7:0	WDStatM	RO	0x80	ResSys	WatchDog Status MSB

20. SLEEP COUNTER WAKE-UP

The SC wake-up function generates a timeout which may be used as a sleep wake-up or as an asynchronous interrupt or event generation timer in active or standby mode. The max delay is 35min, programmable in 125us steps. When the timeout is reached an interrupt **IntSlpCnt** or event **EvtSlpCnt** will be asserted. If the circuit was in sleep mode the interrupt or event will wake it up and software execution will start, if the circuit was in active or standby mode it will interpret the interrupts or events execute the instruction code.

In order to wake-up from sleep or to see the interrupt or event the corresponding interrupt and event must not be masked.

The SCWU uses a 24-bit counter down counter running on the internal RC 8 KHz oscillator.

Figure 34, Sleep wake-up counter architecture

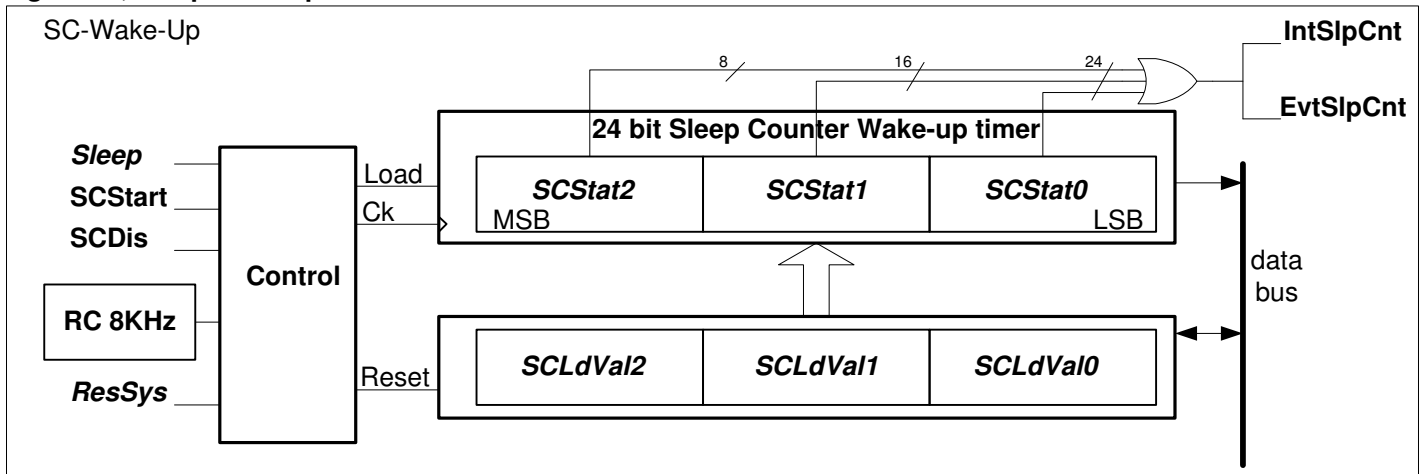

The counter state shall be readable by registers **RegSCStat2** (MSB), **RegSCStat1** and **RegSCStat0**.

Note:

Due to asynchronous domain crossing the SW may read the status during its change i.e. a nonsense value. Only two consecutive reads of the same stable value can assure about its correctness if the SC is running.

Note:

As sleep counter is a state machine running at low frequency, two consecutive actions from CPU on sleep-counter as stop or start shall be separated by at least 2.5 ms delay.

Once the counter reaches 0x000000 value then **IntSlpCnt** and **EvtSlpCnt** will be asserted regardless of the mode. The counting is stopped.

20.1 SC WAKE-UP ENABLING

The counter can only start when **SCDis**=‘0’ (enabled).

If **SCDis** = ‘0’ the counter starts automatically when system enters in sleep mode. When the counter starts it will first load the **RegSCLdVal2,1,0** and then downcount from the loaded value. The current counter value can be read in the status registers **RegSCStat2,1,0**. The default load value is 0x008000 which corresponds to a timeout of 4.1s. An active SC wake-up will automatically switch on the internal RC 8 kHz oscillator.

SCStart can be used to trim the SC in active mode. Charge sharing effects influence the SCWKUP timing slightly when going into Sleep mode. Resulting timings are therefore up to 2.2ms longer than expected.

Note:

SCStart shall not be set to ‘1’ before going in sleep mode it shall be used only in active mode to trim the sleep counter wake-up delay.

20.2 SC WAKE-UP DISABLING

If **SCDis** = ‘1’ the counter will be disabled regardless of the mode.

The counter will stop when **SCStart** is set to '0' or after Sleep mode wake-up. Once stopped, the counter will keep its current value.

The SC wake-up function is reset by **ResSys**.

Note:

Due to asynchronous domain crossing the reload and following start takes 2-3 SC clocks (~250-375 us).

Note:

*If in sleep mode system is woke-up by another source as SC wake-up (by PortA) before SC reaches 0x000000 then the SC needs 2-3 clocks cycle before stopping. If system enter again in sleep mode before proper SC stop, SC do not reload **RegSCLdVal2,1,0** then SC delay is shorter than expected.*

20.3 SC WAKE-UP REGISTERS

0x0073		RegSCCfg			SleepCounter Configuration
Bits	Name	Type	ResVal	ResSrc	Description
7	SCDis	RW	0	ResSys	SleepCounter Disable
6	SCStart	RW	0	ResSys	SleepCounter Start/Run
5:0	-	NI	-	-	Not implemented

0x0074		RegSCLdVal0			SleepCounter Start/Load value B0-LSB
Bits	Name	Type	ResVal	ResSrc	Description
7:0	SCLdVal0	RW	0x00	ResSys	SleepCounter Start/Load value B0-LSB

0x0075		RegSCLdVal1			SleepCounter Start/Load value B1
Bits	Name	Type	ResVal	ResSrc	Description
7:0	SCLdVal1	RW	0x80	ResSys	SleepCounter Start/Load value B1

0x0076		RegSCLdVal2			SleepCounter Start/Load value B2-MSB
Bits	Name	Type	ResVal	ResSrc	Description
7:0	SCLdVal2	RW	0x00	ResSys	SleepCounter Start/Load value B2-MSB

0x0077		RegSCStat0			SleepCounter Status B0-LSB
Bits	Name	Type	ResVal	ResSrc	Description
7:0	SCStat0	RO	0x00	ResSys	SleepCounter Status Byte0-LSB

0x0078		RegSCStat1			SleepCounter Status B1
Bits	Name	Type	ResVal	ResSrc	Description
7:0	SCStat1	RO	0x80	ResSys	SleepCounter Status Byte1

0x0079		RegSCStat2			SleepCounter Status B2-MSB
Bits	Name	Type	ResVal	ResSrc	Description
7:0	SCStat2	RO	0x00	ResSys	SleepCounter Status Byte2-MSB

21. 10-BITS ADC

Two blocks compose the ADC:

- The conditioner
- The ADC converter

The conditioner allows sampling different range of analog inputs even signal having a dynamic higher than VSUP. It consists to decrease the reference and the analog input in a range adapted for the ADC converter.

21.1 CONDITIONER

21.1.1 RANGE SELECTION

It consists to attenuate the external analog input range and external reference. It is used to adapt external range to internal range limited to maximum 1.7V as illustrated in the following diagram.

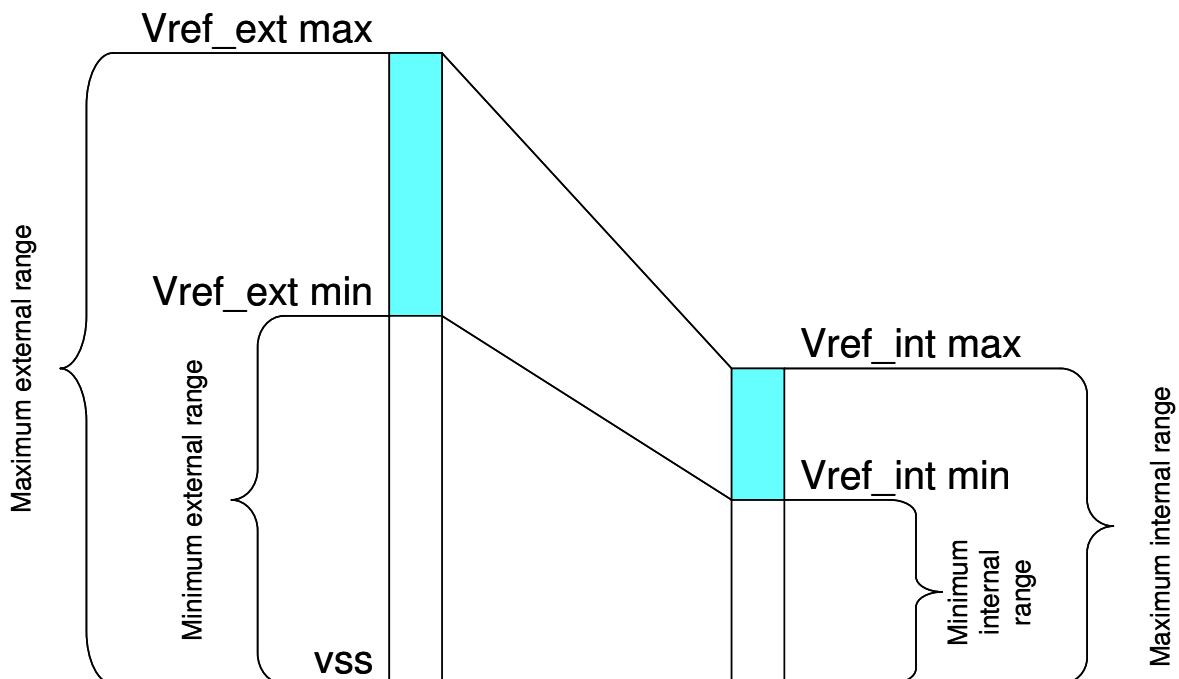

Vref_ext max: Maximum external range
Vref_ext min: Minimum external range
Vref_int max: Maximum internal range = 1.7V
Vref_int min: Minimum internal range = 1.1V

External reference and attenuation factor called range shall be calculated to get an internal reference in a window of 1.1V to 1.7V. There is another condition to fulfill; the maximum external reference shall not be above VSUP if VSUP > VREG. If VSUP < VREG the maximum external reference is 1.7V.

There are 4 possible ranges. The factor shall be chosen to get an internal reference in the window of 1.1V to 1.7V according to the following table:

Range	Vref_ext min	Vref_ext max
13/13	1.10 V	1.70 V
9/13	1.59 V	2.46 V
6/13	2.38 V	3.68 V
4/13	3.57 V	5 V ⁽¹⁾

(1) The maximum external range is limited by maximum power supply 5V

External – internal references relation with 13/13 range

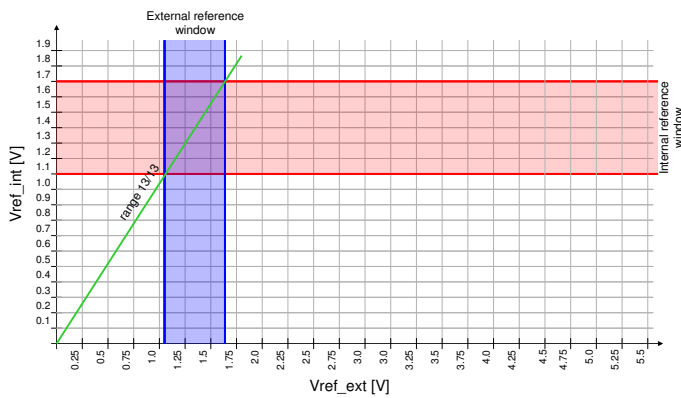

External – internal references relation with 9/13 range

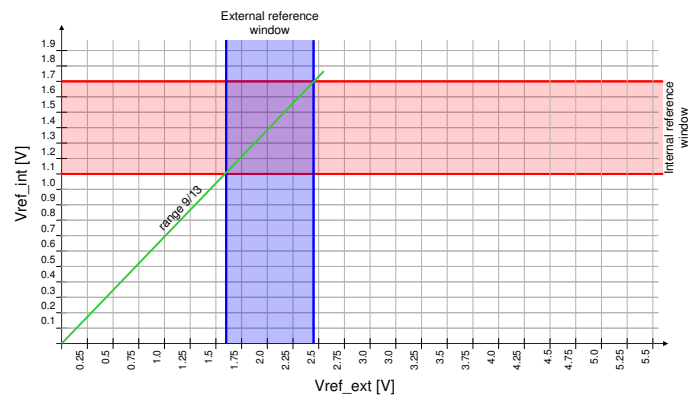

External – internal references relation with 6/13 range

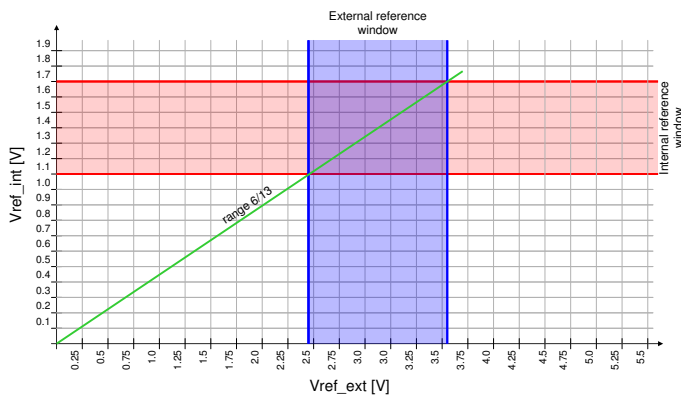

External – internal references relation with 4/13 range

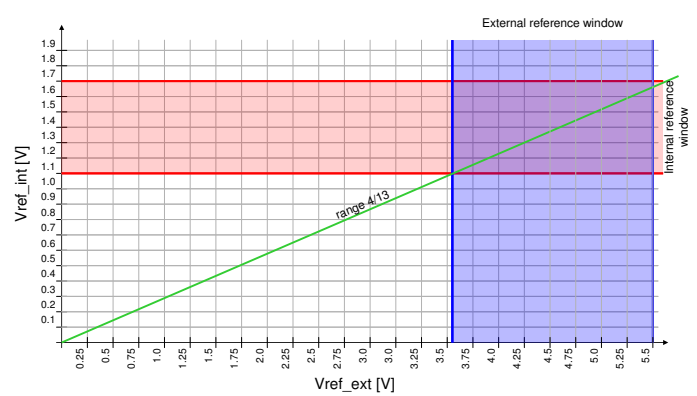

The selection of the attenuation factor is done with **ADCSelRange[1:0]** in the register **RegADCCfg2[5:4]**.

ADCSelRange[1:0]	Attenuation factor
00	13/13
01	9/13
10	6/13
11	4/13

21.1.2 REFERENCE SELECTION

There are three different possible references selectable with **ADCSelRef[1:0]** in the register **RegADCCfg2[7:6]**.

ADCSelRef[1:0]	reference	origin
00	VBGR	Internal reference
01	VREF_EXT	PA2
10	VSUP	Main supply VSUP
11	unused	-

When external reference **VREF_EXT** is used, **PA[2]** shall be configured in analog mode: **RegPAOE[2] = '0'**, **RegPAInpE[2] = '0'**, **RegPAPU[2] = '0'** and **RegPAPD[2] = '0'**.

Note:

Always allow the reference voltage to stabilize before starting an ADC measure. When running on the internal reference this stabilization time is 130us from **ADCEn** until stable reference voltage. It is possible to start the reference prior to enabling of the ADC, refer to 23.

21.1.3 ANALOG INPUT SELECTION

There are 9 possible analog inputs selectable with **ADCSelSrc[2:0]** in register **ADCOut1[6:4]**. When the temperature sensor is active (**EnTempSens** in register **RegADCCfg1[4] = '1'**) the temperature sensor is automatically set as ADC

analog input. **StsTempSens** in register **RegADCOut1[3]** is a copy of **EnTempSens** and is not writable. It allows checking if the temperature sensor is enable at each read of ADC data output.

EnTempSens	ADCSeISrc[2:0]	ADC source
0	000	PA0
0	001	PC0
0	010	PA1
0	011	PC1
0	100	PA2
0	101	PC2
0	110	PA3
0	111	PC3
1	xxx	temperature sensor

21.2 ADC OFFSET TRIM SELECTION

Depending on the ADC configuration or if the ADC is used with the temperature sensor, the ADC offset shall be set differently. When the internal voltage is used, the ADC range selection has effect only on the analog input signal. Then the offset has to be adapted to the selected range. There is also a dedicated offset trim word used when the analog input is the temperature sensor in order to remove the offset error introduced by the sensor itself.

All these trimming words are contained in the row 62 sector 5 of the NVM (refer to the chapter 5.5). The offset trim to use according to the configuration is as follows:

ADC configuration	ADC offset trim	DM address
ADC ref = internal Vref Range 4/13	ADCOffsetRng4_13[10:0]	MSB 0x6FD1[10:8] LSB 0x6FD0[7:0]
ADC ref = internal Vref Range 6/13	ADCOffsetRng6_13[10:0]	MSB 0x6FCF[10:8] LSB 0x6FCE[7:0]
ADC ref = internal Vref Range 9/13	ADCOffsetRng9_13[10:0]	MSB 0x6FCD[10:8] LSB 0x6FCC[7:0]
Temperature sensor	ADCOffsetTemp[10:0]	MSB 0x6FC9[10:8] LSB 0x6FC8[7:0]
All other configurations	ADCOffsetRng13_13[10:0]	MSB 0x6FCB[10:8] LSB 0x6FCA[7:0]

The trimming word has to be copied from the NVM to the related registers: MSB in **RegADCOffsetM** DM address 0x005A and LSB in **RegADCOffsetL** DM address 0x0059.

Note: ADC offset is coded and memorized in NVM on 11 bits. Their value can be above 0x3FF.

21.3 ADC CONFIGURATIONS

21.3.1 RUNNING MODE

The 6819 ADC has two possible running modes:

- Continuous mode: the ADC runs continuously until the software stops it.
- One shot mode: the ADC makes just one single acquisition.

To start the ADC in continuous mode, **RunContMeas** in register **RegADCCfg1[6]** shall be set at '1'. To start a single sample, **RunSinglMeas** in register **RegADCCfg1[5]** shall be set at '1'. Continuous mode has the priority over single measurement.

Always fully define the ADC setup before starting any ADC measurement.

21.3.2 ADC ENABLING

Before to start an acquisition, **EnADC** in register **RegADCCfg1[7]** shall be set at '1'. When the ADC is stopped in continuous mode, **EnADC** shall be set at '0' before to launch any other acquisition otherwise all next measurement will be corrupted.

Note:

EnADC will also enable the bandgap reference voltage. If the BGR is used as ADC reference the user must wait for the BGR to stabilize before starting any measurement. Refer to 23.

If an external reference is used or the BGR was already enabled before - and is stabilized - still allow 5us setup time from **EnADC** to start of measuring.

21.3.3 ADC SAMPLING RATE

The ADC can select 8 different sampling rates. ADC is running on **Ck_Hi** whatever the clock configuration. When the CPU and the Prescalers are not running on **Ck_Hi**, the clock for ADC shall be forced. Meaning that **FrcEnRC15M** or **FrcEnRC2M** or **FrcEnExt** shall be forced at '1' and **Ck_Hi** shall be connected to the clock source forced.

The maximum sampling rate of the ADC is 100kS/s, the ADC needs 22 clocks for each sample, than the maximum selectable ADC frequency is 2.2MHz. The clock selection is done with **ADCSmplRate[2:0]** in register **RegADCCfg1[3:1]**. Following table shows the relation between the clock source selection and the sampling rate.

ADCSmplRate[2:0]	Clock division factor	Sampling rate kS/s		
		Ck_Hi = 15MHz	Ck_Hi = 2MHz	Ck_Hi = 4MHz Xtal
000	1 (default)	denied	91.81	denied
001	2	denied	45.45	91.81
010	4	denied	22.73	45.45
011	8	83.78	11.36	22.73
100	16	41.89	5.68	11.36
101	32	21.85	2.84	5.68
110	64	10.47	1.42	2.84
111	1	denied	91.81	denied

The first conversion shall be ignored. Then in single mode the conversion need 44 clocks. This is automatically managed by the 6819, the event is generated only after the second conversion. Following table shows the relation between the conversion duration and the clock source selection.

ADCSmplRate[2:0]	Clock division factor	Conversion duration us		
		Ck_Hi = 15MHz	Ck_Hi = 2MHz	Ck_Hi = 4MHz Xtal
000	1 (default)	denied	22.00	denied
001	2	denied	44.00	22.00
010	4	denied	88.00	44.00
011	8	23.87	176.00	88.00
100	16	47.74	352.00	176.00
101	32	95.49	704.00	352.00
110	64	191.87	1408.00	704.00
111	1	denied	22.00	denied

21.3.4 LOW NOISE MODE

ADC low noise mode consists to start the ADC conversion only when the CPU is in stand by mode by setting **ADCLowNoise** in register **RegADCCfg2[3]** at '1'. The CPU is waked up by ADC event or ADC interrupt when the conversion is done and ADC result available if they are unmasked.

21.3.5 8BIT ADC SELECTION

It is possible to set the size of the ADC result between 10 or 8-bits. If high precision is not required, it allows simplifying the software as the data are in 8bit. In this case two LSB bits are lost. The other bits are shifted in register **RegADCOut0[7:0]**. In 10-bits mode the result is split in registers **RegADCOut1[1:0]** (2 MSB bits) and **RegADCOut0[7:0]** (8 LSB bits).

21.4 ADC ACQUISITION SEQUENCE

The ADC generates an interrupt or an event when the acquisition is done and the result available for CPU. Thank to the event it is possible to force the CPU in std-by mode, the event wake-up the CPU automatically when the ADC result is available. It allows in continuous saving time because the CPU does not need to go through the handler. It is also possible to react by polling the event with conditional jump JEV.

Int0StsADC in register **RegInt0Sts[4]** is the interrupt generated at the end of each acquisition.
Evt1StsADC in register **RegEvtSts[1]** is the event generated at the end of each acquisition.

The ADC result is available in registers **RegADCOut1[1:0]** (2 MSB bits) and **RegADCOut0[7:0]** (8 LSB bits). To ensure that a new acquisition between reading **RegADCOut1[1:0]** and **RegADCOut0[7:0]** does not corrupt the ADC result, **RegADCOut0[7:0]** is stored in a shadow register when **RegADCOut1[1:0]** is read. Both registers are read in fact exactly in the same time. **RegADCOut1[1:0]** shall always be read first.

RegADCOut1.ADCOutLSB is the 11th bits result LSB and it is not guaranteed.

The bit **ADCBusy** in read-only register **RegADCOut1[7]** is at '1' when the ADC is working. It allows detecting the end of acquisition in one shot mode by polling.

21.5 ADC REGISTERS

0x0055		RegADCCfg1			ADC Configuration - 1
Bits	Name	Type	ResVal	ResSrc	Description
7	EnADC	RW	0	ResSys	Enable ADC Block
6	RunContMeas	RW	0	ResSys	Run Continues measurement
5	RunSinglMeas	STS	0	ResSys	Run/Start Single measurement
4	EnTempSens	RW	0	ResSys	Enable Temperature Sensor
3:1	ADCSmplRate	RW	'000'	ResSys	ADC Sample Rate setup - continues mode.
0	ADC8bit	RW	0	ResSys	ADC 8bit Result mode

0x0056		RegADCCfg2			ADC Configuration - 2
Bits	Name	Type	ResVal	ResSrc	Description
7:6	ADCSelRef	RW	'00'	ResSys	ADC Reference selection
5:4	ADCSelRange	RW	'00'	ResSys	ADC Range selection
3	ADCLowNoise	RW	0	ResSys	ADC Low noise measurement mode
2:0	-	NI	-	-	Not implemented

0x0057		RegADCOut0			ADC Output-0 (LSB)
Bits	Name	Type	ResVal	ResSrc	Description
7:0	ADCOut0	RO	0x00	ResSys	ADC Output-0: 10bit=LSB(8:1), 8bit-(10:3)

0x0058		RegADCOut1			ADC Output-1 (MSB)
Bits	Name	Type	ResVal	ResSrc	Description
7	ADCBusy	RO	0	ResSys	ADC in progress
6:4	ADCSelSrc	RW	'000'	ResSys	ADC Input Source selection
3	StsTempSens	RO	0	ResSys	Enable Temperature Sensor Status
2	ADCOutLSB	RO	0	ResSys	ADC Output HW-LSB(0)
1:0	ADCOut1	RO	'00'	ResSys	ADC Output-1: 10bit-MSB(10:9), 8bit-N/A

0x0059		RegADCOffsetL			ADC Offset LSB (7:0)
Bits	Name	Type	ResVal	ResSrc	Description
7:0	ADCOffsetL	RW	0x00	ResSys	ADC Offset LSB (7:0)

0x005A		RegADCOffsetM			ADC Offset MSB (10:8)
Bits	Name	Type	ResVal	ResSrc	Description
7:3	-	NI	-	-	Not implemented
2:0	ADCOffsetM	RW	'100'	ResSys	ADC Offset MSB (10:8)

22. TEMPERATURE SENSOR

22.1 TEMPERATURE SENSOR ENABLING

The temperature sensor is enabled when **EnTempSens** in register **RegADCCfg1** is written at '1'. When the temperature sensor is enabled it is automatically selected by the ADC as input source. Read-only bit **StsTempSens** in register **RegADCOut1** is a copy of **EnTempSens**. Thank to it the status of temperature sensor is given on each ADC result read access.

22.2 TEMPERATURE SENSOR REGISTERS

0x0055		RegADCCfg1			ADC Configuration - 1
Bits	Name	Type	ResVal	ResSrc	Description
7	EnADC	RW	0	ResSys	Enable ADC Block
6	RunContMeas	RW	0	ResSys	Run Continues measurement
5	RunSinglMeas	STS	0	ResSys	Run/Start Single measurement
4	EnTempSens	RW	0	ResSys	Enable Temperature Sensor
3:1	ADCSmplRate	RW	'000'	ResSys	ADC Sample Rate setup - continues mode.
0	ADC8bit	RW	0	ResSys	ADC 8bit Result mode

0x0058		RegADCOut1			ADC Output-1 (MSB)
Bits	Name	Type	ResVal	ResSrc	Description
7	ADCBusy	RO	0	ResSys	ADC in progress
6:4	ADCSelSrc	RW	'000'	ResSys	ADC Input Source selection
3	StsTempSens	RO	0	ResSys	Enable Temperature Sensor Status
2	ADCOutLSB	RO	0	ResSys	ADC Output HW-LSB(0)
1:0	ADCOut1	RO	'00'	ResSys	ADC Output-1: 10bit-MSB(10:9), 8bit-N/A

Note:

Temperature sensor calibration values are stored in row 62 sector 5 as described in chapter 4.6. Temperature tolerances of production test are described in chapter 4.6.1.

When **EnTempSens** is written at '1' it is necessary to wait 10ms before to launch an ADC acquisition.

23. BAND GAP

The band gap voltage reference, written also BGR in this document, generates the reference voltage used for the following peripherals:

- VLD (while VLD enabled)
- ADC, (while ADC enabled CPU in active or standby mode)
- OPAMP (while OPAMP enabled and the BGR or the VLD reference is selected as one of the OPAMP inputs)
- BGR output on PA[6], (while the reference voltage is output)
- NVM memory modification (fully controlled by ROM-API)

First time enabled allow for 130us reference voltage stabilization time before using one of the above mention functions needing the BGR voltage.

The reference voltage is automatically enabled as soon as one of the above mentioned functions is enabled.

The reference voltage can be forced on by writing the bit **NVMEWrite** in register **RegBgrCfg[6]** to '1' prior to use it for destination function. This allows using the VLD and ADC immediately after enabling (no need to wait first for BGR stabilization).

The BGR can be used as an external reference as well. Writing '1' in **BgrEnOut** in register **RegBgrCfg[7]** connects the voltage reference to **PA[6]** that shall be configured as analog pad before (digital output and input mode off and no pull's).

23.1 BAND GAP REGISTER

0x0060		RegBgrCfg			BandGap reference configuration
Bits	Name	Type	ResVal	ResSrc	Description
7	BgrEnOut	RW	0	ResSys	Enable BandGap reference output to Port
6	NVMEWrite	RW	0	ResSys	Enables BandGap in active mode
5:0	-	NI	-	-	Not implemented

Note:

When connecting the reference voltage to the PA[6] output , the reference voltage may drop during the switching transition due to charge sharing from the internal reference voltage node to the external PA[6] pad and its attached capacitance. In this case the settling time can be longer than 130us.

Always use the reference voltage only once it is completely stabilized.

24. VLD

The Voltage Level Detector (VLD) compares a voltage on a terminal pad to a fix reference and returns the result '1' or generates an interrupt if the voltage is below the reference. The measurement is static meaning that there is no need to start any sequence and the selected voltage source terminal is continuously supervised. The reference voltage VVLD is factory pretrimmed.

24.1 VLD SOURCE AND LEVEL SELECTION

There are 8 terminals selectable with **VLDSeISrc[2:0]** in register **RegVLDCfg1[5:3]** as follows:

VLDSeISrc[2:0]	Source
000	<i>VSUP (default)</i>
001	<i>PA1</i>
010	<i>PA2</i>
011	<i>PC1</i>
100	<i>PC5</i>
101	<i>PA6</i>
110	<i>PC6</i>
111	<i>PA7</i>

There are 32 target level selectable with **VLDSeILev[4:0]** in register **RegVLDCfg2[4:0]** as follows:
Refer to the electrical specification for the voltage levels.

VLDSeILev[4:0]	Level	VLDSeILev[4:0]	Level
00000	VLD0	10000	VLD16
00001	VLD1	10001	VLD17
00010	VLD2	10010	VLD18
00011	VLD3	10011	VLD19
00100	VLD4	10100	VLD20
00101	VLD5	10101	VLD21
00110	VLD6	10110	VLD22
00111	VLD7	10111	VLD23
01000	VLD8	11000	VLD24
01001	VLD9	11001	VLD25
01010	VLD10	11010	VLD26
01011	VLD11	11011	VLD27
01100	VLD12	11100	VLD28
01101	VLD13	11101	VLD29
01110	VLD14	11110	VLD30
01111	VLD15	11111	VLD31

24.2 VLD ENABLE

VLD is enable writing '1' in **EnVLD** in register **RegVLDCfg1[7]**. After enabling it is recommended to wait 150us before enabling the related interrupt or read the VLD result to allow the reference voltage to stabilize. This stabilization wait is only needed if the internal BGR voltage was not enabled for 150us prior to enabling the VLD. If the BGR was already enabled before still allow 20us for the VLD reference to stabilize after VLD enabling. Refer also to 23.

24.3 VLD RESULT

When the voltage measured is below the VLD level the read-only bit **VLDRes** in register **RegVLDCfg1[6]** is at '1'.

24.4 VLD INTERRUPT

An interrupt is generated when the voltage measured is below the VLD level. The VLD interrupt **IntSts2Vld** is in register **RegInt2Sts[7]**.

24.5 VLD TRIMMING

The VLD reference voltage **VVLD** is trimmed in production independently of the BGR. The trimming value is stored in the NVM at the address **0x6FF9**. During the boot ROM sequence this value is copied in **TrimVLD[3:0]** in register **RegTrimVLD**. The user can modify this register to move slightly all VLD levels.

24.6 VLD REGISTERS

0x005E		RegVLDCfg1			VLD Configuration - 1
Bits	Name	Type	ResVal	ResSrc	Description
7	EnVLD	RW	0	ResSys	Enable VLD
6	VLDRes	RO	0	ResSys	VLD Result/Output
5:3	VLDSelSrc	RW	'000'	ResSys	Select VLD Input/Source
2:0	-	NI	-	-	Not implemented

0x005F		RegVLDCfg2			VLD Configuration - 2
Bits	Name	Type	ResVal	ResSrc	Description
7:5	-	NI	-	-	Not implemented
4:0	VLDSelLev	RW	0x00	ResSys	Select VLD Level

0x02A4		RegTrimVLD			Trimming value for VLD
Bits	Name	Type	ResVal	ResSrc	Description
7:4	-	NI	-	-	Not implemented
3:0	TrimVLD	RW	0x8	ResAna	Trimming value for VLD

25. RC OSCILLATOR

There are 2 main internal RC oscillators:

- 15MHz oscillator (runs at 14.7456 MHz but called 15MHz oscillator)
- 2MHz oscillator

These 2 oscillators are factory pretrimmed, the trim value is stored in the NVM at the following addresses:

- 15MHz oscillator: 0x6FFD
- 2MHz oscillator: 0x6FFC

The boot ROM sequence copies the 15MHz trimming value from the NVM into **TrimOsc15M** in register **RegTrimOsc15M** and the 2MHz trimming value from the NVM into **TrimOsc2M** in register **RegTrimOsc2M**. The user can modify these two trimming in their destination register **RegTrimOsc15M**, **RegTrimOsc2M**.

Note:

Before any CALL of sub-routine erasing or writing the NVM, the default RC timing values from NVM shall be restored.

25.1 RC OSCILLATORS REGISTERS

0x02A2		RegTrimOsc15M			Trimming value for the 15 MHz Oscillator
Bits	Name	Type	ResVal	ResSrc	Description
7:0	TrimOsc15M	RW	0x80	ResAna	Trimming value for the 15 MHz Oscillator

0x02A3		RegTrimOsc2M			Trimming value for the 2 MHz Oscillator
Bits	Name	Type	ResVal	ResSrc	Description
7:0	TrimOsc2M	RW	0x80	ResAna	Trimming value for the 2 MHz Oscillator

26. XTAL OSCILLATOR 32KHZ

XTAL oscillator is connected to the terminal pads **PA4 (XIN)** and **PC4 (XOUT)**. These two pads shall be configured in analog mode (output and input mode disable and no pull's) before to launch the XTAL oscillator.

Note:

The XTAL oscillator shall be located as close as possible to the 6819. Both wires XIN and XOUT shall be routed as short as possible on the board.

The temperature range is limited to [-40°C ; 60 °C]

For all information concerning the different configuration related to the 32 KHz XTAL oscillator, refer to the chapter "Oscillator and Clocking structure".

27. RESONATOR 4MHZ

RC resonator is connected to the terminal pads **PA4 (XIN)** and **PC4 (XOUT)**. These two pads shall be configured in analog mode (output and input mode disable and no pull's) before to launch the resonator.

Note:

The Resonator shall be located as close as possible to the 6819. Both wires **XIN** and **XOUT** shall be routed as short as possible on the board.

Two capacitors of 39pF shall be implemented on the board. The first between **XIN** and **VSS**, the second between **XOUT** and **VSS** as describe in the following schematic:

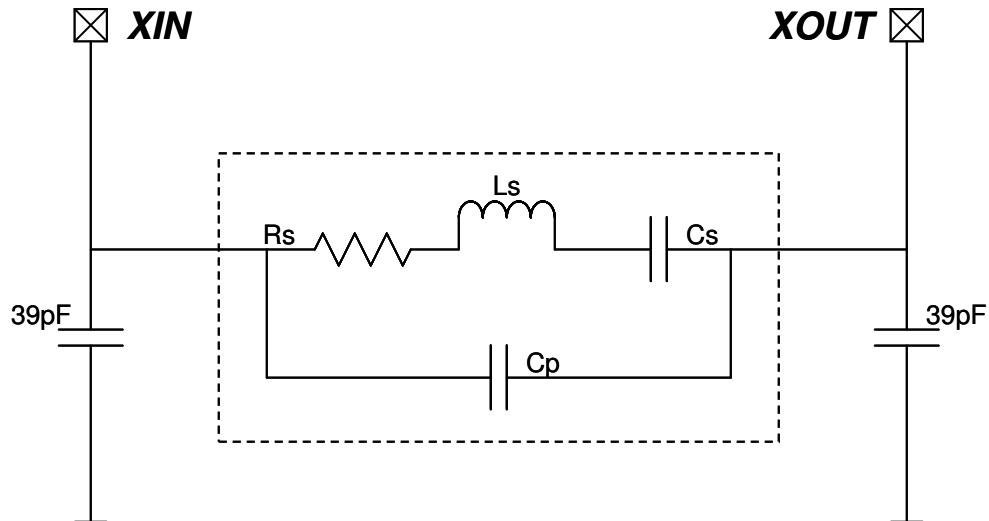

For all information concerning the different configuration related to the 4MHz resonator, refer to the chapter "Oscillator and Clocking structure".

28. 8KHZ OSCILLATOR

The 8kHz oscillator is used mainly for the watch-dog and the sleep counter wake-up system. Its frequency is not trimmable. However timings generated by the 8kHz oscillator can be calibrated with the trimmed 2Mhz or 15Mhz oscillator.

For very low power applications it is also possible possible to use the 8kHz oscillator for the CPU and the prescalers

For all information concerning the different configuration related to the 8kHz oscillator, refer to the chapter “Oscillator and Clocking structure”.

29. ANALOG OPAMP

Each pin of the OPAMP in 6819 can be connected to different terminal or other peripherals. The positive input selection is done with **OpAmpSelInpPos[1:0]** in register **RegOpAmpCfg2[7:0]** as following:

OpAmpSelInpPos[1:0]	positive input
00	PA3
01	PC3
10	VBGR
11	VVLD

The negative input selection is done with **OpAmpSelInpNeg[1:0]** in register **RegOpAmpCfg[7:0]** as following:

OpAmpSelInpNeg[1:0]	negative input
00	PA2
01	PC2
10	VBGR
11	VVLD

When the OPAMP is enable and comparator disable, the output can be mapped on to different terminal with **OpAmpSelOut** in register **RegOpAmpCfg[3]** as follows:

OpAmpSelOut	output
0	PA1
1	PC1

29.1 SELECT OPAMP/COMPARATOR

To enable the OPAMP, **EnOpAmp** in register **RegOpAmpCfg1[7]** shall be set at '1'. In this case the selected terminals are connected to the OPAMP. The terminal shall be configure in analog mode before to enable the OPAMP, it is not done automatically (output and input mode disable and no pull's).

To enable the comparator **EnOpAmp** in register **RegOpAmpCfg1[7]** and **EnComp** in register **RegOpAmpCfg1[6]** shall set at '1'. In this mode the output is not mapped on any of the two terminals **PA1** or **PC1**.

29.2 OPAMP SUPPLY

The supply of the OPAMP is connected to VSUP.

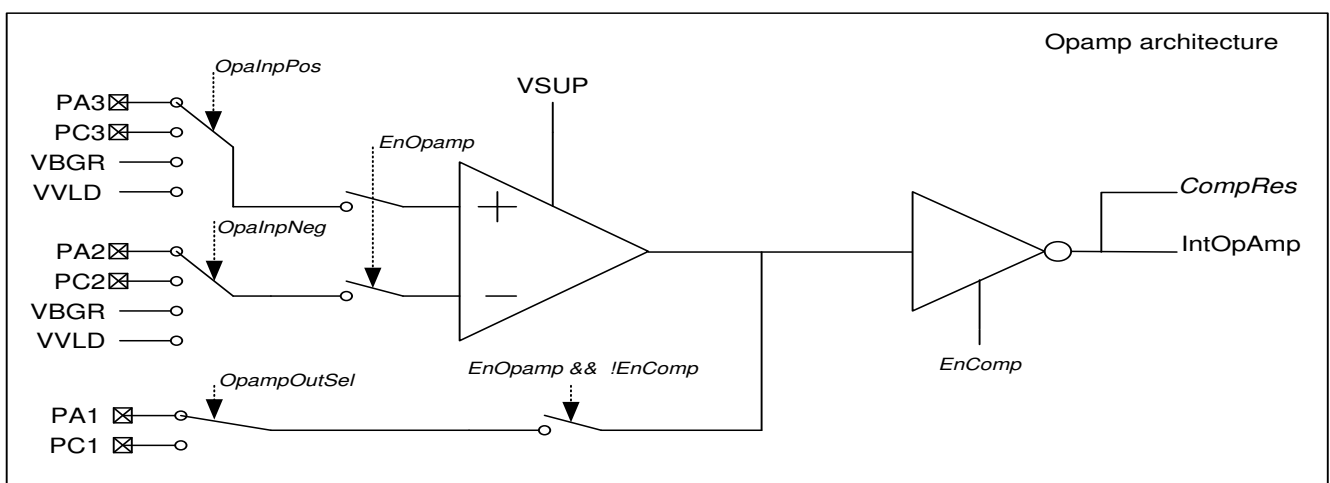

Note:

The input range of the input is limited to [0V ; Vsup - 1V]
 The output range is rail to rail [0V ; Vsup]

29.3 COMPARATOR RESULT

The comparator result is mapped on the read-only bit **CompRes** in register **RegOpAmpCfg1[4]**. The comparator can generate an interrupt mapped on **Int1StsOpAmp** in register **RegInt1Sts[3]**. It is possible to set on which edge the interrupt is generated with **SelComplnt[1:0]** in register **RegOpAmpCfg1[3:2]** as follows:

SelComplnt[1:0]	interrupt generation
00	no interrupt
01	interrupt on rising edge
10	interrupt on falling edge
11	interrupt on both edges

29.4 OPAMP REGISTERS

0x005B		RegOpAmpCfg1			OpAmp Configuration - 1
Bits	Name	Type	ResVal	ResSrc	Description
7	EnOpAmp	RW	0	ResSys	Enable OP Amplifier
6	EnComp	RW	0	ResSys	Enable/Select OpAmp as Comparator
5	-	NI	0		
4	CompRes	RO	0	ResSys	Comparator Result
3:2	SelComplnt	RW	'00'	ResSys	Selector/Enable of Comparator Interrupt
1:0	-	NI	-	-	Not implemented

0x005C		RegOpAmpCfg2			OpAmp Configuration - 2
Bits	Name	Type	Bits	Name	Type
7:6	OpAmpSelInpPos[1:0]	RW	0	ResAna	Select opamp positive input source
5:4	OpAmpSelInpNeg[1:0]	RW	0	ResAna	Select opamp negative input source
3	OpAmpSelOut	RW	0	ResAna	Select opamp output pad
2:0	-	NI	-	-	Not implemented

30. BLOCKS CONSUMPTION

Following table shows the consumption of different blocks of EM6819FX-B300 in typical conditions. Consumption of system, CPU, NVM access etc... have been excluded for each block to get only the consumption of the block itself.

Temperature: 25°C
VSUP: 3V

Block	Consumption	Special conditions
Brown-out	600 nA	
Watch-dog	40 nA	
Sleep counter wake-up	90 nA	
RC 15 MHz	23 uA	
RC 2 MHz	6 uA	
RC 8 kHz	90 nA	
Xtal	400 nA	
BGR	11 uA	
VLD	7.2 uA	VLD source: VSUP VLD level: 0
ADC	50 uA	Sampling rate: 12.5 kS/s Range: 8/8 Reference: BGR (Not included in consumption) ADC Input: PC1 = 0.618 V (Vref / 2)
OpAmp	52 uA	Comparator mode: Off OpAmp supply: VSUP Input neg: PA2 = 0V Input pos: PA3 = VSUP (3V) Output: PC1 = VSUP (3V)
	18 uA	Comparator mode: Off OpAmp supply: VSUP Input neg: PA2 = VSUP (3V) Input pos: PA3 = 0V Output: PC1 = 0V
Timers	26 uA	Timer1 consumption considered CPU clock: 8kHz Prescaler1 clock: 2 MHz Prescaler2 clock: 8 kHz Timer1 clock: Prescaler1 Ck15 (2 MHz)
SPI	16 uA	SPI mode: Master, Auto start SCLK clock: 2 MHz (not mapped on any pad) SIN: PA4 = 0V SOUT: Not mapped on any pad Sequence: Write 0xAA ; 0x55 continuously in RegSPIDOut

31. TYPICAL T AND V DEPENDENCIES

31.1 IDD CURRENTS

31.1.1 GENERAL CONDITIONS

Mode	Description
Active	CPU: running at selected clock Software: makes a loop and writes/reads continuously the RAM Prescaler1: Running on ck_hi when available otherwise ck_lo Prescaler2: Always running on ck_lo Brown-out: Enable Watch-dog: Running on 8kHz Regulator: Vreg = 1.8V enable
Stand-by	CPU: Halt state Software: No software executed Prescaler1: Running on ck_hi when available otherwise ck_lo Prescaler2: Always running on ck_lo Brown-out: Enable Watch-dog: Running on 8kHz Regulator: Vreg = 1.8V enable
Sleep	CPU: Halt state Software: No software executed Prescaler1: Disable Prescaler2: Disable Brown-out: Disable Watch-dog: Disable Regulator: Vreg = 1.8V enable

Figure 35, Temperature and supply dependency for consumption @ 15 MHz

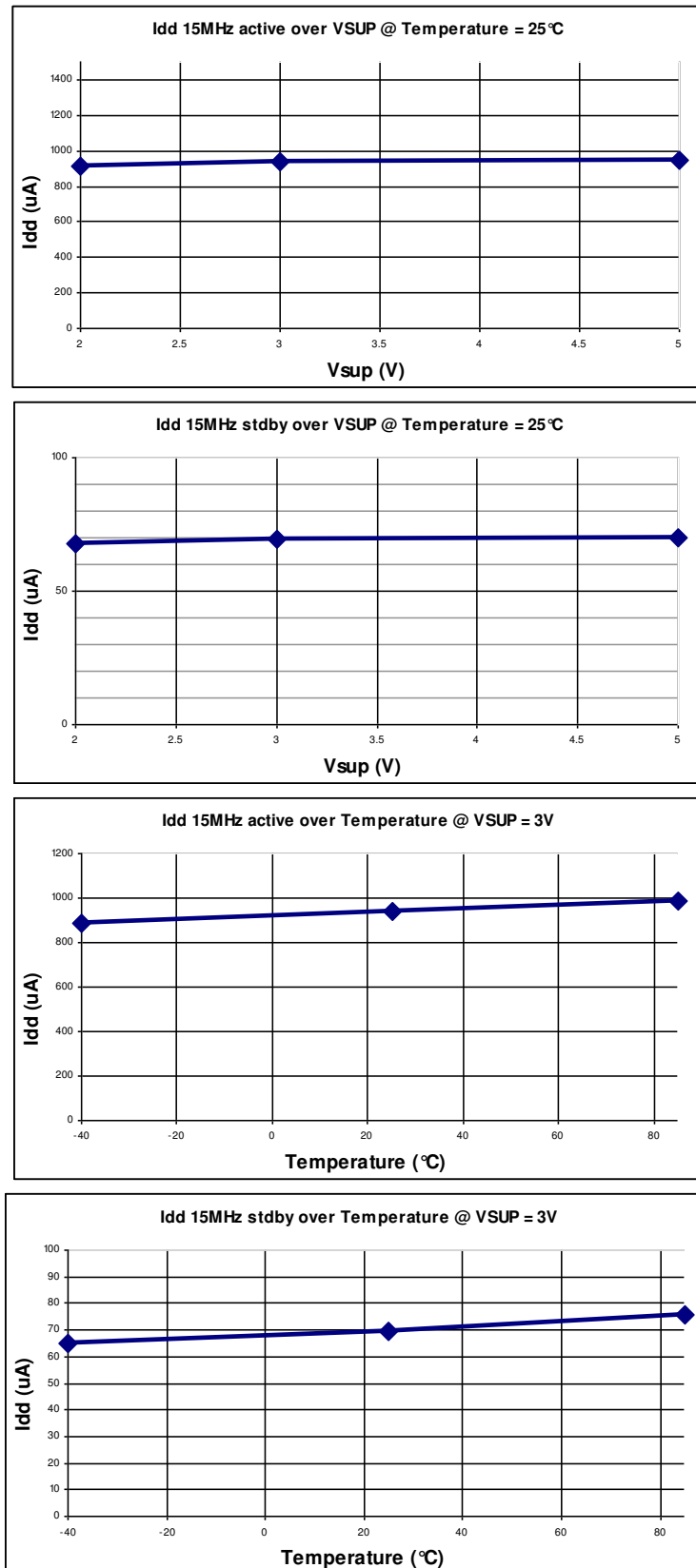

Figure 36, Temperature and supply dependency for consumption @ 2 MHz

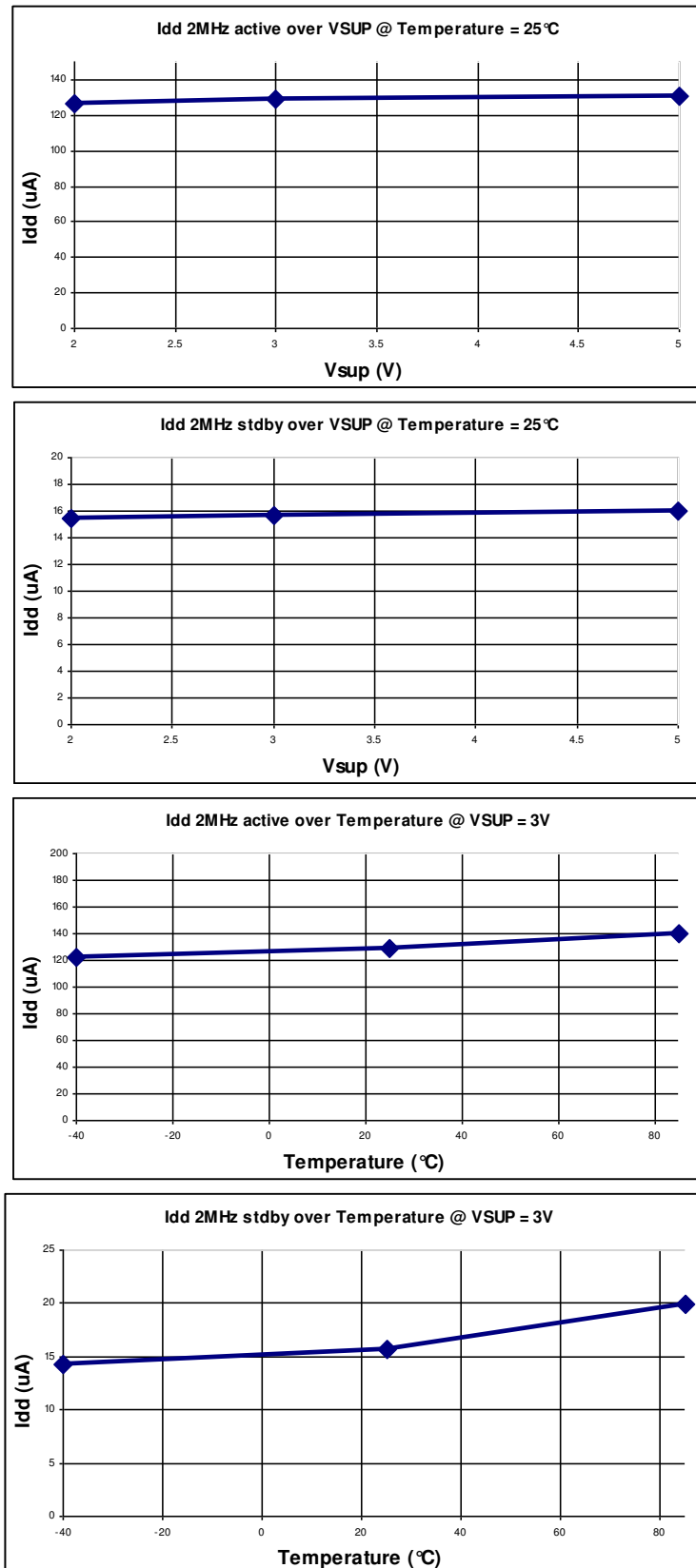

Figure 37, Temperature and supply dependency for consumption @ 4 MHz resonator

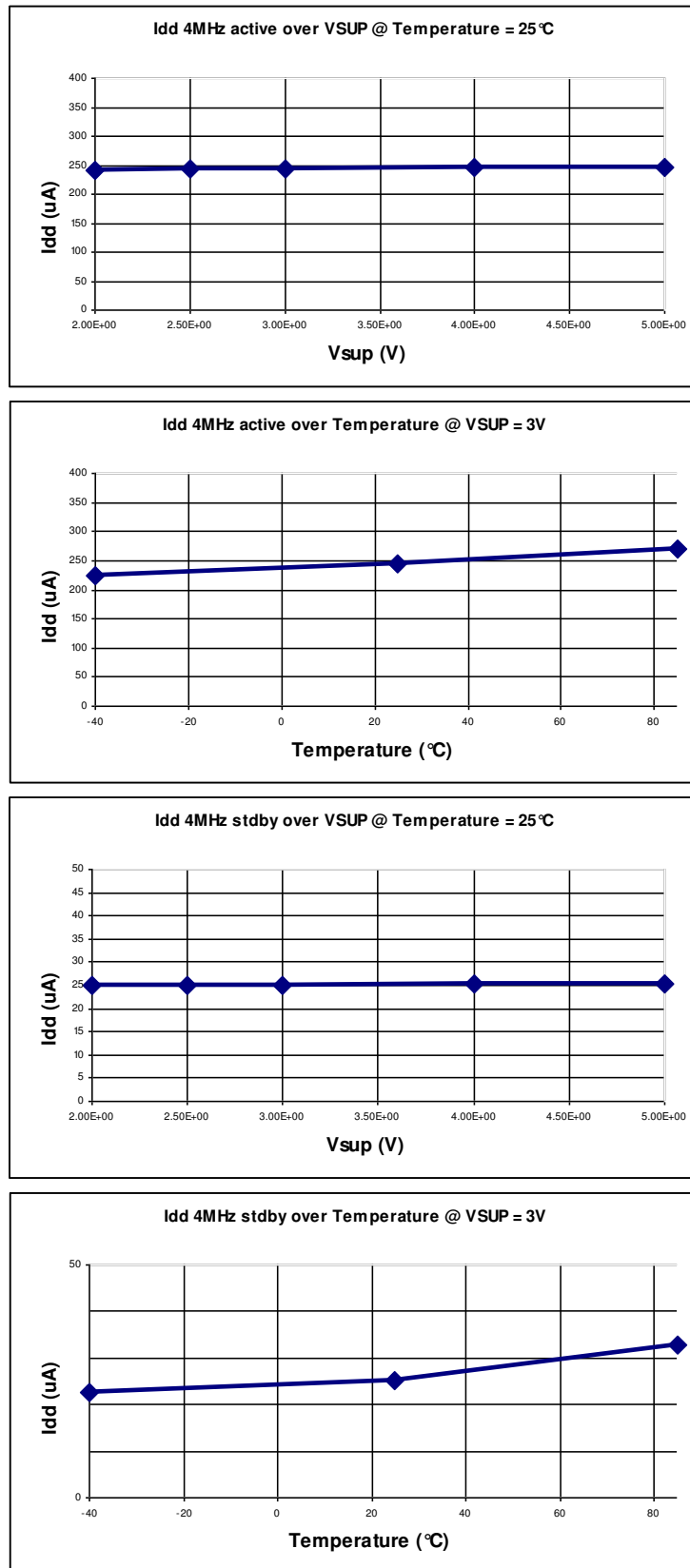

Figure 38, Temperature and supply dependency for consumption @ 32 kHz XTAL

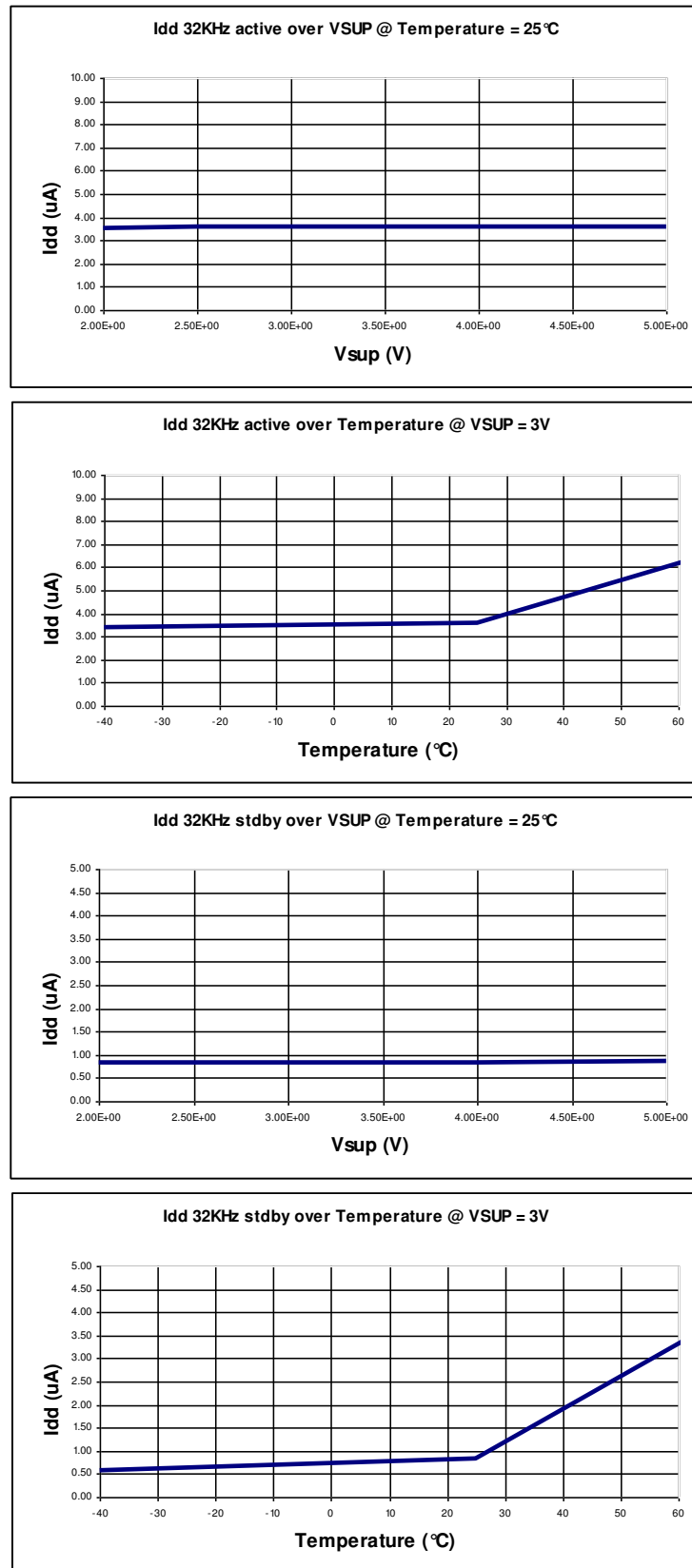

Figure 39, Temperature and supply dependency for consumption @ 8 kHz

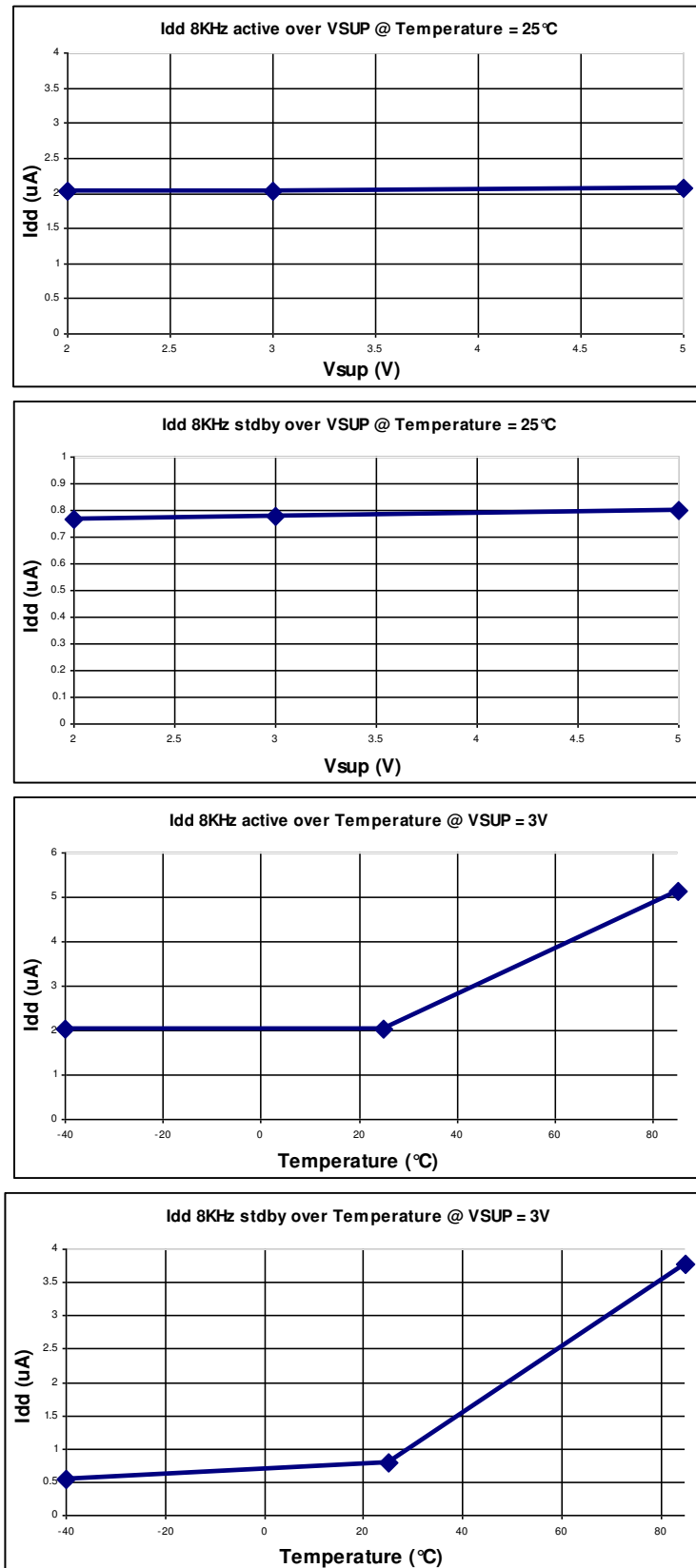
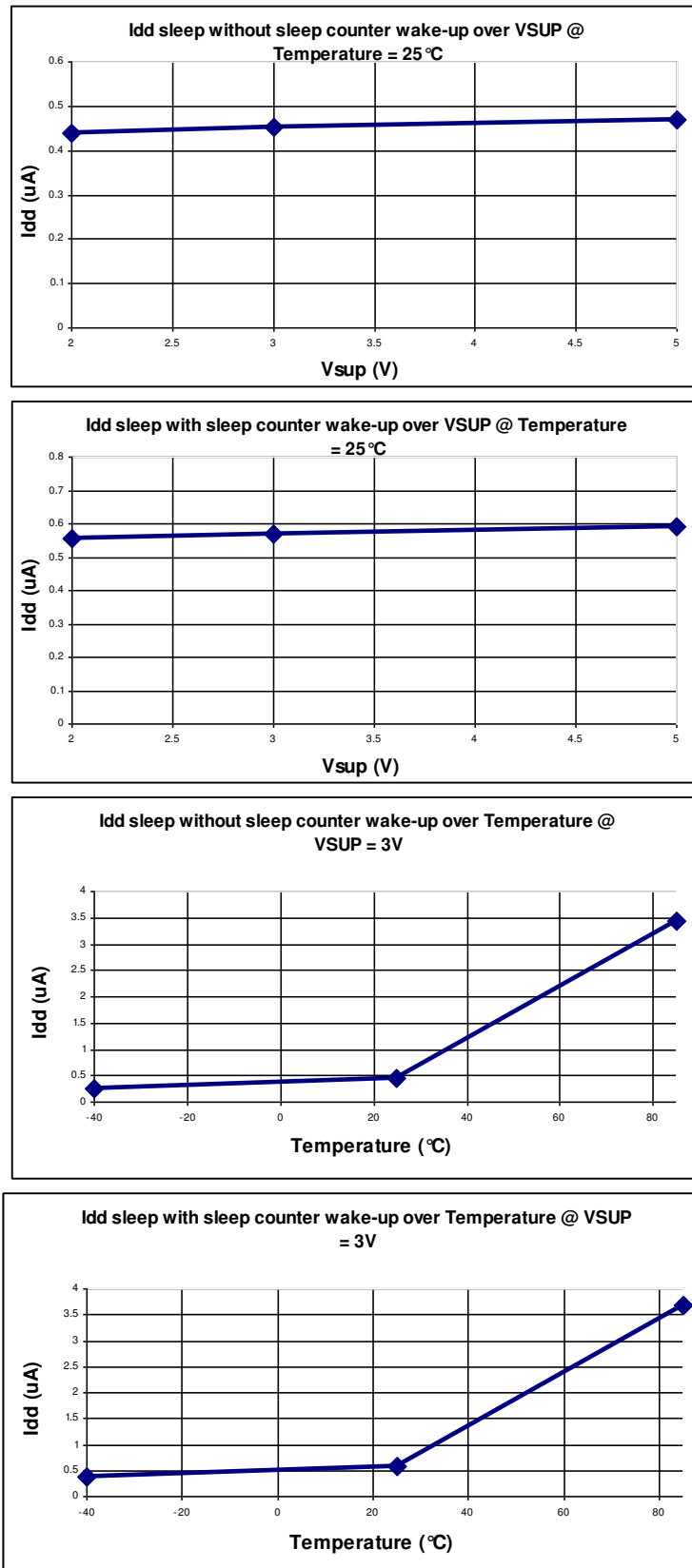
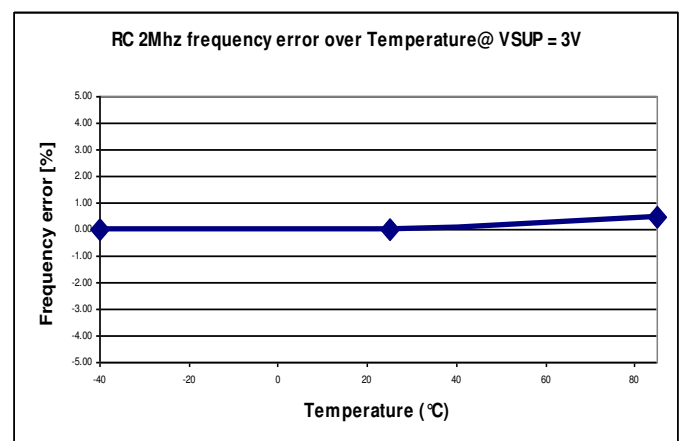
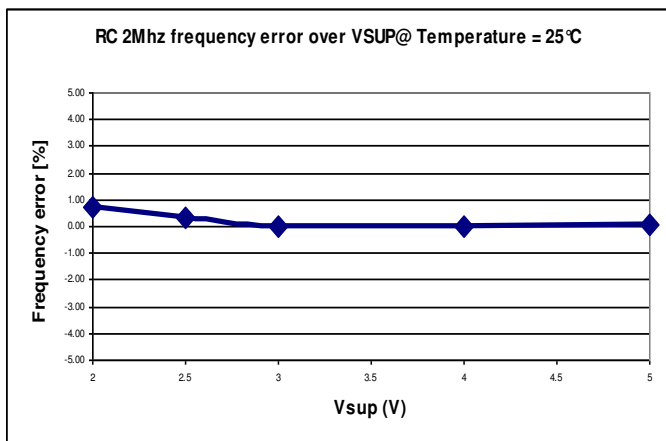
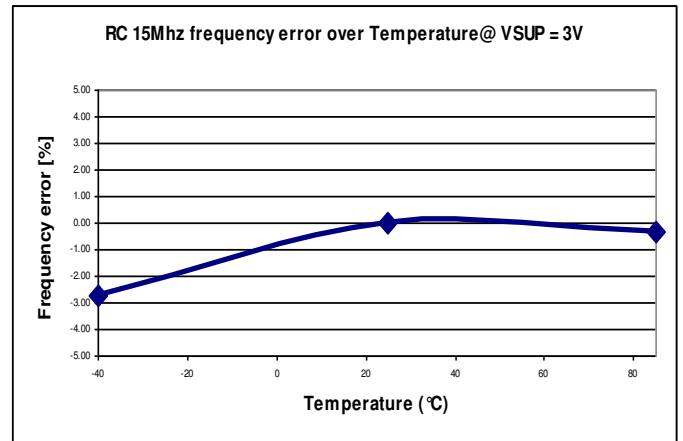
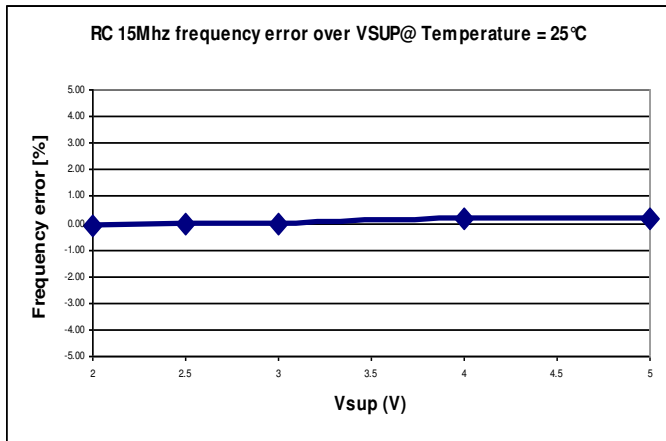

Figure 40, Temperature and supply dependency for consumption in sleep mode



31.2 RC OSCILLATOR 15MHZ AND 2MHZ

Figure 41, Temperature and supply dependency for internal RC oscillators (without software compensation)



31.3 XTAL 32 KHZ AND RESONATOR 4MHZ

Figure 42, Temperature dependency for xtal 32 KHz and resonator 4MHz

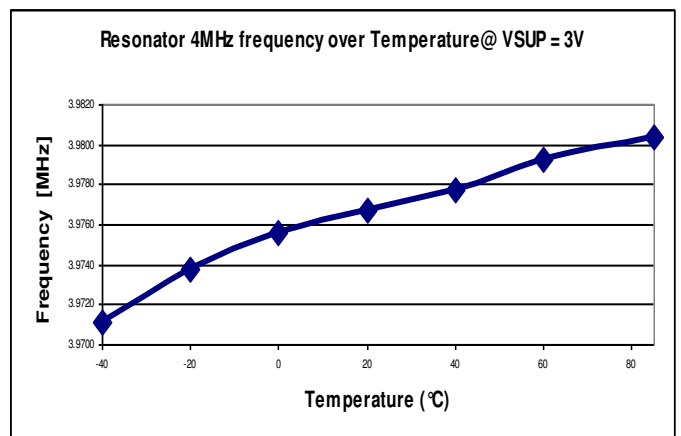
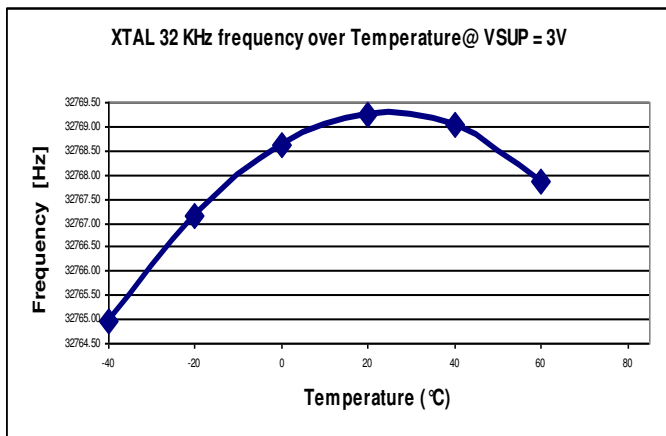

Note : Figure done with Crystal Microcrystal DS15, and resonator CERALOCK Murata CSTLS4M00G53-B0

32. ELECTRICAL SPECIFICATION

32.1 ABSOLUTE MAXIMUM RATINGS

	Min.	Max.	Units
Power supply $V_{SUP}-V_{SS}$	- 0.2	+5.2	V
Input voltage	$V_{SS} - 0.2$	$V_{SUP}+0.2$	V
Storage temperature	- 40	+ 125	°C
Electrostatic discharge to JESD22 A114 with ref. to V_{SS}	-2000	+2000	V
Maximum soldering conditions Packages are Green-Mold and Lead-free	As per Jedec J-STD-020C		

Stresses above these listed maximum ratings may cause permanent damage to the device.

Exposure beyond specified electrical characteristics may affect device reliability or cause malfunction

32.2 HANDLING PROCEDURES

This device has built-in protection against high static voltages or electric fields; however, anti-static precautions should be taken as for any other CMOS integrated circuit.

Unless otherwise specified, proper operation can only occur when all terminal voltages are kept within the supply voltage range.

32.3 STANDARD OPERATING CONDITIONS

Parameter	MIN	TYP	MAX	Unit	Description
Temperature	-40	25	85	°C	
V_{SUP} range	2	3	5	V	Voltage at power-up
I_{VSS} max			80	mA	Maximum current out of V_{SS} Pin
I_{VSUP} max			80	mA	Maximum current into V_{SUP} Pin
V_{SS}		0		V	Reference terminal
C_{VREG} (1)	400			nF	regulated voltage capacitor
Flash data retention	20			yrs	Read and Erase state retention
Flash cycling			10k	cycle	1 cycle is one erase followed by 1 write

Note 1: This capacitor filters switching noise from V_{SUP} to keep it away from the internal logic and memory cells. In noisy systems the capacitor should be chosen higher than minimum value.

32.4 TYPICAL 32KHZ CRYSTAL SPECIFICATION

F _q		32768		Hz	nominal frequency
R _{qs}		35		KOhm	typical quartz serial resistance
C _L		8.2		pF	typical quartz load capacitance
df/f		± 30		ppm	quartz frequency tolerance

Watch type crystal oscillator (i.e Microcrystal DS15), connected between QIN and Qout terminal.

32.5 TYPICAL 4MHZ RESONATOR SPECIFICATION

F _R		4		MHz	nominal frequency
R _S		9		Ohm	Typical equivalent resistor
C _S		0.007		pF	Typical equivalent serial capacitor
C _P		2.39		pF	Typical equivalent parallel capacitor
L _S		210		mH	Typical equivalent inductor
df/f		± 0.5		%	Resonator frequency tolerance

Watch type resonator oscillator CERALOCK Murata CSTLS4M00G53-B0, connected between QIN and Qout terminal.

32.6 DC CHARACTERISTICS - POWER SUPPLY CURRENTS

Conditions:

In active mode, the software makes a loop and writes/reads continuously the RAM, the following blocks are active:

- NVM instructions read access
- RAM read/write access
- Prescalers 1 & 2
- Selected oscillator
- RC 8kHz
- Regulator
- Brown-out
- Power on reset
- Internal bias current generation

In stand-by mode, the software execution is stopped; the following blocks are active:

- Prescalers 1 & 2
- Selected oscillator
- RC 8kHz
- Regulator
- Brown-out
- Power on reset
- Internal bias current generation

In sleep mode, the software execution is stopped; the following blocks are active:

- RC 8kHz
- Regulator
- Brown-out
- Power on reset
- Internal bias current generation
- All ports pulled low

Following table includes product: EM6819FX-B300

Parameter	Conditions	Symbol	Min.	Typ.	Max. ⁽¹⁾	Unit
ACTIVE Supply Current CPU on RC=15MHz, no div	V _{SUP} =3V, -40 to 85°C, 7.5 MIPS	I _{VSUPA15MD1}		0.91	1.3	mA
ACTIVE Supply Current CPU on RC=2MHz, no div	V _{SUP} =3V, -40 to 85°C, 1 MIPS	I _{VSUPA2MD1}		126	250	uA
ACTIVE Supply Current CPU on XTal=32KHz, no div	V _{SUP} =3V, -40 to 40°C, 16 kIPS	I _{VSUPA32K}		3.3	8	uA
ACTIVE Supply Current CPU on RC=8KHz, no div	V _{SUP} =3V, -40 to 85°C, 4 kIPS	I _{VSUPA8K}		2		uA
Std-by Supply Current Peri on RC=15MHz, no div	V _{SUP} =3V, -40 to 85°C, HF Div=1	I _{VSUPH15MD1}		67		uA
Std-by Supply Current Peri on RC=2MHz, no div	V _{SUP} =3V, -40 to 85°C, HF Div=1 StdByFastWkUp=0	I _{VSUPH2MD1}		14		uA
Std-by Supply Current Peri on XTal=32KHz, no div	V _{SUP} =3V, -40 to 40°C, HF RC off StdByFastWkUp=0	I _{VSUPH32K}		0.8	6	uA
Std-by Supply Current Peri on RC=8KHz, no div	V _{SUP} =3V, -40 to 85°C, HF RC off StdByFastWkUp=0	I _{VSUPH8K}		0.77	16	uA
	V _{SUP} =3V, -40 to 40°C, HF RC off StdByFastWkUp=0	I _{VSUPH8K}		0.77	7	uA
Sleep Supply Current Wake-up counter on	V _{SUP} =3V, -40 to 85°C, RC 8kHz on StdByFastWkUp=0,	I _{VSUPSWK}		0.51	15	uA
	V _{SUP} =3V, -40 to 40°C, RC 8kHz on StdByFastWkUp=0	I _{VSUPSWK}		0.51	3	uA
Sleep Supply Current Wake-up counter off	V _{SUP} =3V, -40 to 85°C, RC8kHz off StdByFastWkUp=0	I _{VSUPSLEEP}		0.4		uA

32.7 DC CHARACTERISTICS – VOLTAGE DETECTION LEVELS

Parameter	Conditions	Symbol	Min.	Typ.	Max.	Unit
POR V_{SUP} static level on rising edge	-40 to 85 °C	V_{PORRIS}		0.7	0.86	V
POR V_{SUP} static level on falling edge	-40 to 85 °C	V_{PORFAL}		0.58	0.74	V
Temperature coefficient	-40 to 25 °C	$T_{VLD_COEF_LO}$		-0.003		%/°C
	25 to 85 °C	$T_{VLD_COEF_HI}$		0.003		%/°C
VLD0, VBAT decreasing	25 °C	V_{VLD0}		0.800		V
VLD1, VBAT decreasing	25 °C	V_{VLD1}		0.850		V
VLD2, VBAT decreasing	25 °C	V_{VLD2}		1.140		V
VLD3, VBAT decreasing	25 °C	V_{VLD3}		1.150		V
VLD4, VBAT decreasing	25 °C	V_{VLD4}		1.160		V
VLD5, VBAT decreasing	25 °C	V_{VLD5}		1.165		V
VLD6, VBAT decreasing	25 °C	V_{VLD6}		1.170		V
VLD7, VBAT decreasing	25 °C	V_{VLD7}		1.175		V
VLD8, VBAT decreasing	25 °C	V_{VLD8}		1.180		V
VLD9, VBAT decreasing	25 °C	V_{VLD9}		1.185		V
VLD10, VBAT decreasing	25 °C	V_{VLD10}		1.190		V
VLD11, VBAT decreasing	25 °C	V_{VLD11}		1.700		V
VLD12, VBAT decreasing	25 °C	V_{VLD12}		1.800		V
VLD13, VBAT decreasing	25 °C	V_{VLD13}		2.000		V
VLD14, VBAT decreasing	25 °C	V_{VLD14}		2.600		V
VLD15, VBAT decreasing	25 °C	V_{VLD15}		2.800		V
VLD16, VBAT decreasing	25 °C	V_{VLD16}		3.000		V
VLD17, VBAT decreasing	25 °C	V_{VLD17}		3.160		V
VLD18, VBAT decreasing	25 °C	V_{VLD18}		3.600		V
VLD19, VBAT decreasing	25 °C	V_{VLD19}		3.980		V
VLD20, VBAT decreasing	25 °C	V_{VLD20}		4.000		V
VLD21, VBAT decreasing	25 °C	V_{VLD21}		4.020		V
VLD22, VBAT decreasing	25 °C	V_{VLD22}		4.040		V
VLD23, VBAT decreasing	25 °C	V_{VLD23}		4.060		V
VLD24, VBAT decreasing	25 °C	V_{VLD24}		4.080		V
VLD25, VBAT decreasing	25 °C	V_{VLD25}		4.100		V
VLD26, VBAT decreasing	25 °C	V_{VLD26}		4.120		V
VLD27, VBAT decreasing	25 °C	V_{VLD27}		4.140		V
VLD28, VBAT decreasing	25 °C	V_{VLD28}		4.160		V
VLD29, VBAT decreasing	25 °C	V_{VLD29}		4.180		V
VLD30, VBAT decreasing	25 °C	V_{VLD30}		4.200		V
VLD31, VBAT decreasing	25 °C	V_{VLD31}	4.193	4.220	4.247	V
VLD trim bit step / LSB				1.7		mV/V

32.8 DC CHARACTERISTICS – REFERENCE VOLTAGE

Parameter	Conditions	Symbol	Min.	Typ.	Max.	Unit
Temperature coefficient	-40 to 85 °C	T_{BGR_COEF}	-38.5		38.5	uV/°C
Reference voltage after trimming	$V_{SUP} = 3V, 40^{\circ}C$	V_{BGP}	1.228	1.236	1.244	V

32.9 DC CHARACTERISTICS – OSCILLATORS

Parameter	Conditions	Symbol	Min. ⁽¹⁾	Typ.	Max. ⁽¹⁾	Unit
32KHz XTAL Integrated Input capacitor	Reference on V _{SS} T=25°C	C _{IN}		7		pF
32KHz Xtal Integrated Output capacitor	Reference on V _{SS} T=25°C	C _{OUT}		14		pF
32KHz Xtal Oscillator start time	V _{SUP} > V _{SUP} Min T = -40 to 60°C	t _{dosc}		0.5	4	s
4MHz resonator start time	V _{SUP} > V _{SUP} Min T = -40 to 85°C	t _{dosc}		1	10	ms
RC oscillator 15MHz Temperature coefficient	-40 to 25°C	T _{RC15_COEF_LO}	-0.018	0.04	0.106	%/°C
RC oscillator 15MHz Temperature coefficient	25 to 85°C	T _{RC15_COEF_HI}	-0.055	0.004	0.069	%/°C
RC Oscillator 15MHz	After trimming, 25°C	F _{RC15M}	14.6129	14.7456	14.8783	MHz
RC Oscillator 15MHz Trimm range 15MHz				+50/-30		%
RC Oscillator 15MHz Trimm step / LSB				47.8		kHz
RC oscillator 2MHz Temperature coefficient	-40 to 25°C	T _{RC2_COEF_LO}	-0.031	0.08	0.177	%/°C
RC oscillator 2MHz Temperature coefficient	25 to 85°C	T _{RC2_COEF_HI}	-0.058	0.05	0.164	%/°C
RC Oscillator 2MHz	After trimming, 25°C	F _{RC1MHz}	1.976	2	2.024	MHz
RC oscillator 2MHz Trimm range 2MHz				+50/-30		%
RC oscillator 2MHz Trimm step / LSB				8.3		kHz
RC Oscillator 8kHz				6.7		

32.10 DC CHARACTERISTICS – OPAMP

Parameter	Conditions	Symbol	Min.	Typ.	Max.	Unit
Open loop gain	$V_{SUP} = 3V, -40 \text{ to } 85^\circ\text{C}$	A_0		70		dB
Gain band width	$V_{SUP} = 3V, -40 \text{ to } 85^\circ\text{C}$	GBW		0.7		MHz
Phase margin	$V_{SUP} = 3V, -40 \text{ to } 85^\circ\text{C}$	PM		60		°
PSRR @ 100kHz	$V_{SUP} = 3V, -40 \text{ to } 85^\circ\text{C}$	PSRR		-24		dB
CMRR @ 100kHz	$V_{SUP} = 3V, -40 \text{ to } 85^\circ\text{C}$	CMRR		-47		dB
Noise	$V_{SUP} = 3V, -40 \text{ to } 85^\circ\text{C} - \text{BW} : 0.1 \text{ to } 100 \text{ Hz}$	NOISE		10		μVrms
Input offset	$V_{SUP} = 3V, -40 \text{ to } 85^\circ\text{C}$	$V_{IN\text{OFFSET}}$	-50	0	50	mV
Reaction time to enable signal	$V_{SUP} = 3V, -40 \text{ to } 85^\circ\text{C}$	T_{ON}		20		us
Output voltage swing	$V_{SUP} = 3.0V, -40 \text{ to } 85^\circ\text{C}$ $V_{INCM} = 350\text{mV}$	V_{OS}		3		V
Current load IOH	$V_{SUP} = 3V, -40 \text{ to } 85^\circ\text{C}$	I_{LOAD}			-180	μA
Current load IOL	$V_{SUP} = 3V, -40 \text{ to } 85^\circ\text{C}$	I_{LOAD}	150			μA
Slew rate	$V_{SUP} = 3.0V, -40 \text{ to } 85^\circ\text{C}$ $V_{INCM} = 350\text{mV}$	SR		0.6		V/us

32.11 DC CHARACTERISTICS – ADC

10 bits ADC considered (RegADCOut1.ADCOutLSB is ignored), meas on 10% to 90%.

Parameter	Conditions	Symbol	Min.	Typ.	Max.	Unit
ADC offset Temperature coefficient	$-40 \text{ to } 25^\circ\text{C} (V_{SUP} = 2.2V - 5V)$	$T_{ADC_COEF_L}$	-0.108	0.01	0.135	%/°C
ADC offset Temperature coefficient	$25 \text{ to } 85^\circ\text{C} (V_{SUP} = 2.2V - 5V)$	$T_{ADC_COEF_HI}$	-0.114	0.02	0.15	%/°C
ADC offset	$V_{SUP} = 3V, 25^\circ\text{C}$ ADCref = V_{BGP} ; Rate 91kS/s Range 13/13	ADC_{Offset}	-4	0	4	LSB
ADC DNL	$V_{SUP} = 3V, -40 \text{ to } 85^\circ\text{C}$ ADCref = V_{BGP} ; Rate 91kS/s; Range 13/13	ADC_{DNL}	-2	0	2	LSB
ADC INL + gain error	$V_{SUP} = 3V, -40 \text{ to } 85^\circ\text{C}$ ADCref = V_{BGP} ; Rate 91kS/s; Range 13/13	ADC_{INLT}	-13	0	13	LSB
ADC INL best fit range 13/13	$V_{SUP} = 3V, -40 \text{ to } 85^\circ\text{C}$ ADCref = V_{BGP} ; Rate 91kS/s; Range 13/13	$ADC_{INLbestfit}$	-6	0	6	LSB
ADC INL best fit range 9/13	$V_{SUP} = 3V, -40 \text{ to } 85^\circ\text{C}$ ADCref = V_{BGP} ; Rate 45kS/s; Range 9/13	$ADC_{INLT6/8}$		+/- 4		LSB
ADC INL best fit range 6/13	$V_{SUP} = 3V, -40 \text{ to } 85^\circ\text{C}$ ADCref = V_{BGP} ; Rate 45kS/s; Range 6/13	$ADC_{INLT4/8}$		+/- 4		LSB
ADC INL best fit range 4/13	$V_{SUP} = 3V, -40 \text{ to } 85^\circ\text{C}$ ADCref = V_{BGP} ; Rate 45kS/s; Range 4/13	$ADC_{INLT4/8}$		+/- 4		LSB
ADC DNL range 13/13	$V_{SUP} = 3V, -40 \text{ to } 85^\circ\text{C}$ ADCref = V_{BGP} ; Rate 45kS/s; Range 13/13	$ADC_{DNL6/8}$		+/- 0.5		LSB
ADC DNL range 9/13	$V_{SUP} = 3V, -40 \text{ to } 85^\circ\text{C}$ ADCref = V_{BGP} ; Rate 45kS/s; Range 9/13	$ADC_{DNL6/8}$		+/- 0.5		LSB
ADC DNL range 6/13	$V_{SUP} = 3V, -40 \text{ to } 85^\circ\text{C}$ ADCref = V_{BGP} ; Rate 45kS/s; Range 6/13	$ADC_{DNL4/8}$		+/- 0.5		LSB
ADC DNL range 4/13	$V_{SUP} = 3V, -40 \text{ to } 85^\circ\text{C}$ ADCref = V_{BGP} ; Rate 45kS/s; Range 4/13	$ADC_{DNL4/8}$		+/- 0.5		LSB

32.12 DC CHARACTERISTICS – TEMPERATURE SENSOR

10 bits ADC considered (RegADCOut1.ADCOutLSB is ignored)

Parameter	Conditions	Symbol	Min.	Typ.	Max.	Unit
Temp sensor result at 25°	$V_{SUP} = 3V$	Tempsens ₂₅	-48.4	-40	-31.6	°C
Temp sensor result at -40°	$V_{SUP} = 3V$	Tempsens ₋₄₀	21.8	25	28.2	°C
Temp sensor result at 40°	$V_{SUP} = 3V$	Tempsens ₄₀	38	40	42	°C
Temp sensor result at 90°	$V_{SUP} = 3V$	Tempsens ₉₀	88	90	92	°C
Temp sensor slope	$V_{SUP} = 3V$; Temp range 0° - 60°	Tempsens _{slope}		4.6		LSB/°

32.13 DC CHARACTERISTICS - I/O PINS

Conditions: T= -40 to 85°C, $V_{SUP}=3.8V$ (unless otherwise specified)

Parameter	Conditions	Symbol	Min.	Typ.	Max.	Unit
Input-Low voltage						
Ports A,B, C		V_{IL}	V_{SS}		0.2* V_{SUP}	V
Input-High voltage						
Ports A,B, C		V_{IH}	0.8* V_{SUP}		V_{SUP}	V
Input Hysteresis PA[7:0], PB[7:0], PC[7:0]	Temp=25°C	V_{Hyst}		0.42		V
IOL PA[7:0], PB[7:0], PC[7:0]	$V_{SUP} = 3.8V$, $V_{OL}=0.3V$	I_{OL}	3	7		mA
	$V_{SUP} = 3.8V$, $V_{OL}=0.5V$	I_{OL}		12		mA
IOH PA[7:0], PB[7:0], PC[7:0]	$V_{SUP} = 3.8V$, $V_{OH}= V_{SUP} - 0.3V$	I_{OH}		-4.1	2	mA
	$V_{SUP} = 3.8V$, $V_{OH}= V_{SUP} - 0.5V$	I_{OH}		-7		mA
Input Pull-down Port A,B,C	$V_{SUP} = 3.8V$, Pin at 2V	R_{PD}	40k	70k	100k	Ohm
Input Pull-up Port A,B,C	$V_{SUP} = 3.8V$, Pin at 0.0V	R_{PU}	40k	70k	100k	Ohm
Input Pull-down TM	$V_{SUP} = 3.8V$, Pin at 2V	R_{PDTM}		20k		Ohm

33. PACKAGE DRAWINGS

33.1 DIMENSIONS OF TSSOP28 PACKAGE

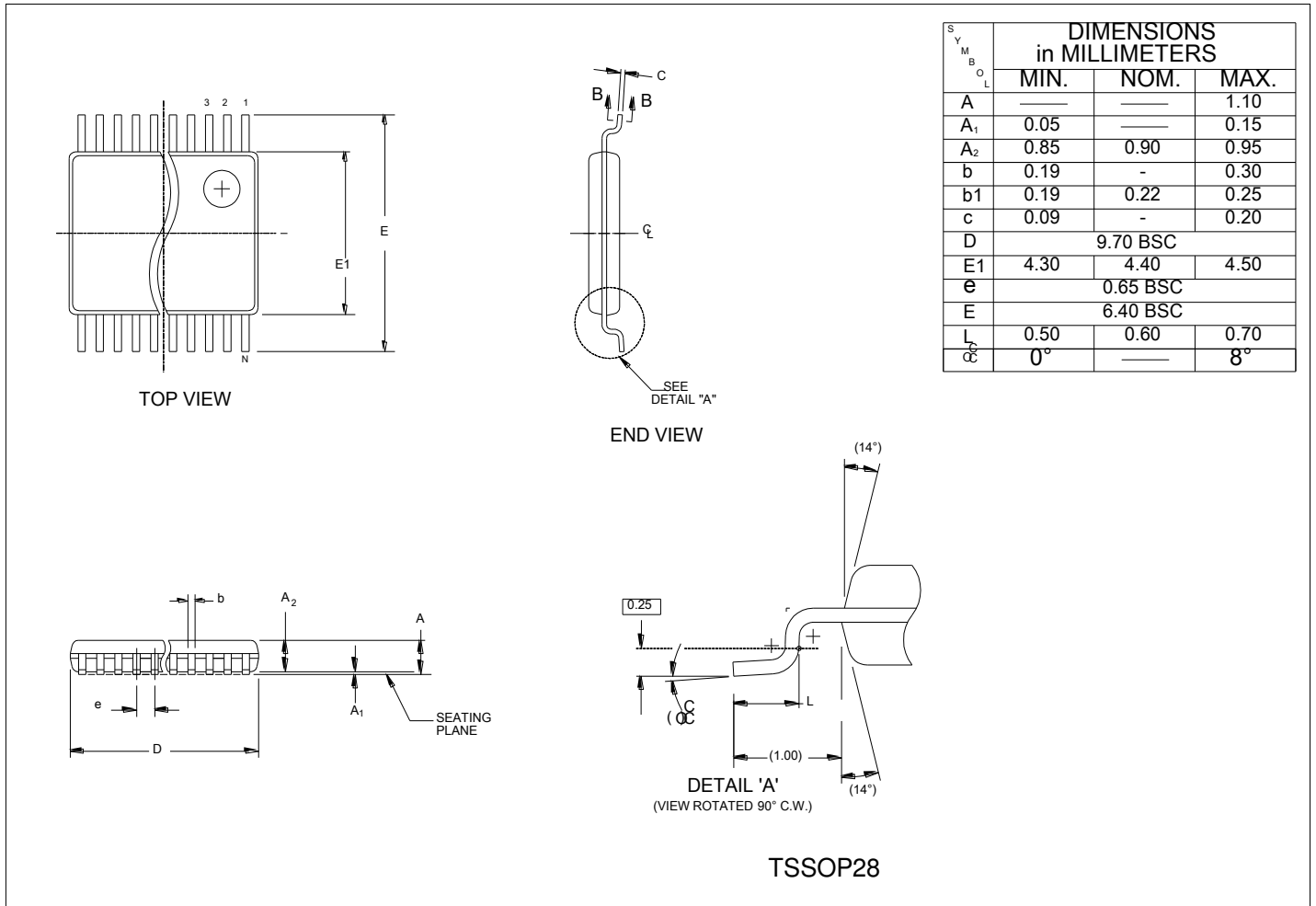

33.2 DIMENSIONS OF TSSOP20 PACKAGE

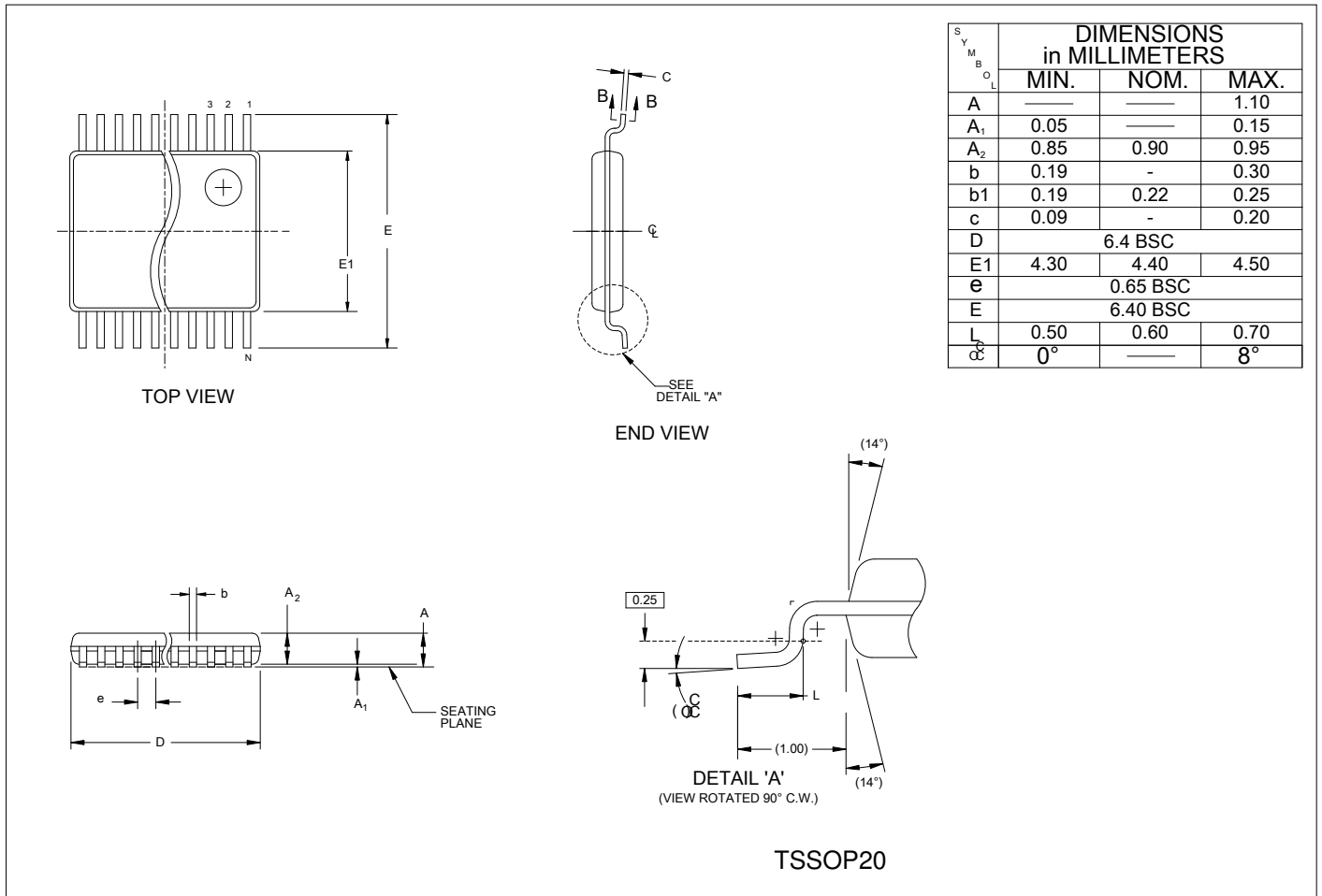

33.3 DIMENSIONS OF TSSOP16 PACKAGE

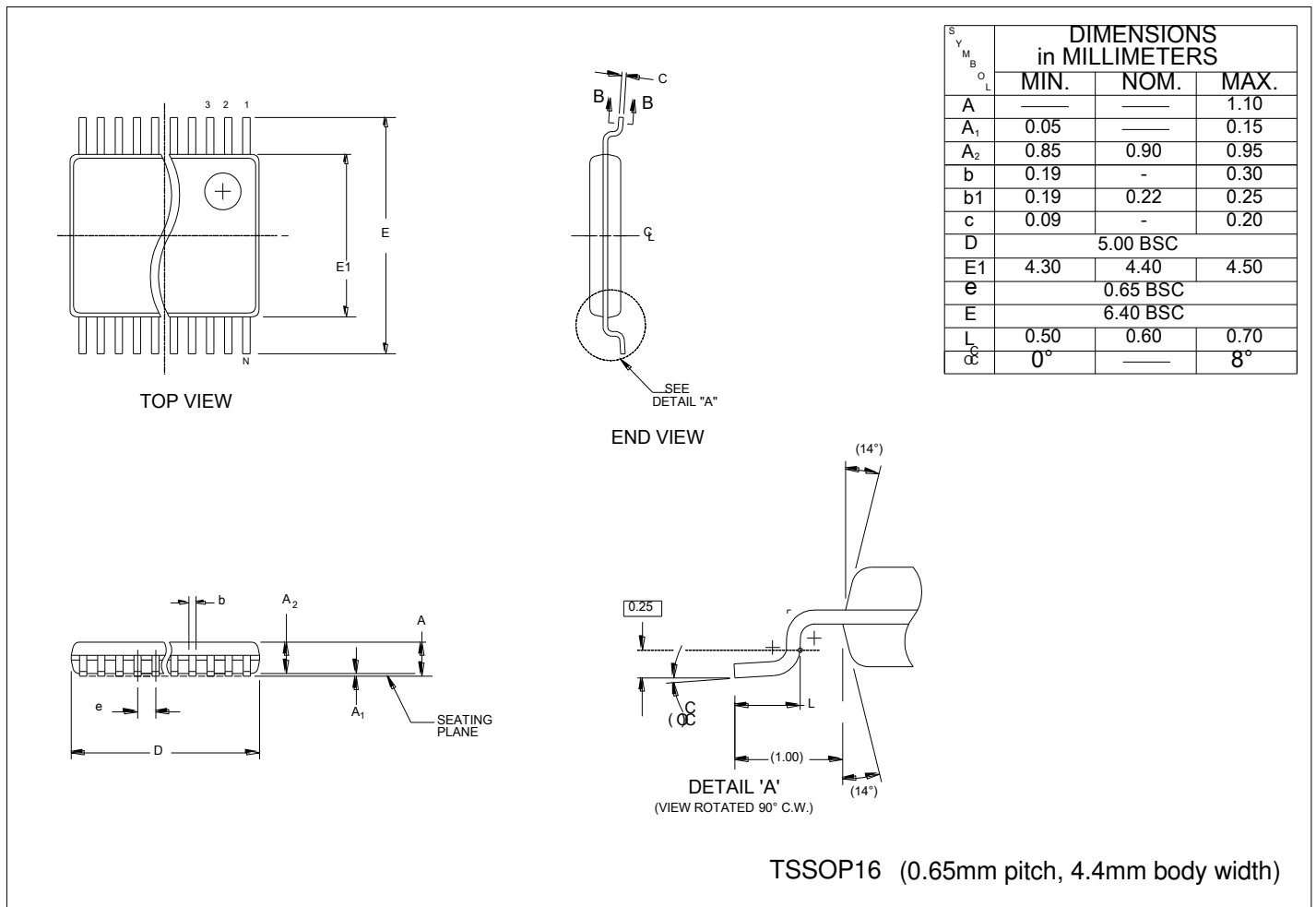

33.4 DIMENSIONS OF QFN20 PACKAGE

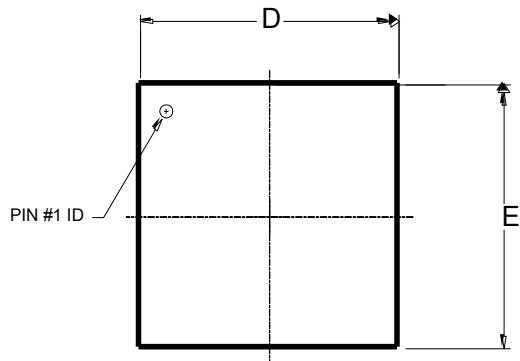

TOP VIEW

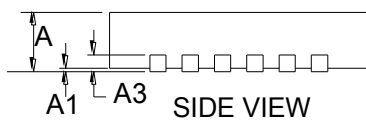

SIDE VIEW

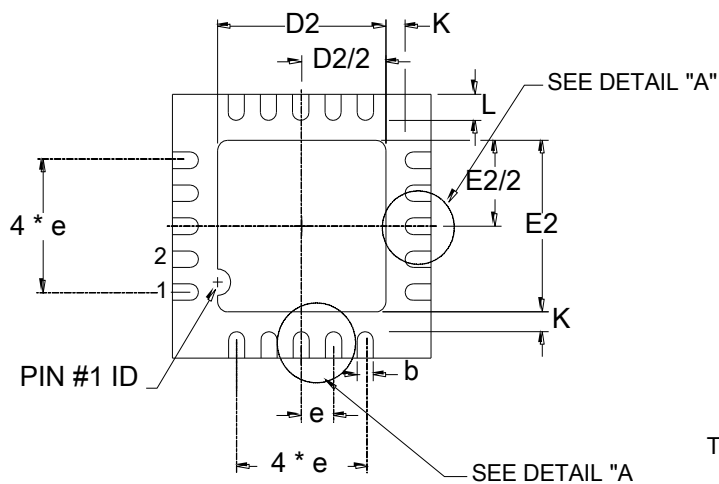

BOTTOM VIEW

	MIN.	NOM.	MAX.
e		0.50	
L	0.45	0.50	0.55
b	0.18	0.25	0.30
D2	2.50	2.60	2.70
E2	2.50	2.60	2.70
A	0.80	0.85	0.90
A1	0.00	0.02	0.05
A3		0.20	
K		0.20min	
D		4.0	
E		4.0	
L1		0.15max	

ALL DIMENSIONS ARE IN MILLIMETERS

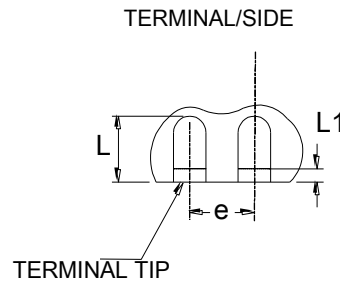

DETAIL "A"



34. PACKAGE MARKING

The first line of the package marking contains the Revision ID and the bonding option
The remaining lines contain Lot identification information

First Line: EM6819FX-B300 XY wheras XY= Circuit hardware information and package pinout

Package markings

- EM6819FX-B300 xG (hardware x = A, B, C release)



35. ORDERING INFORMATION

The full ordering information is composed out of the

- Part number
- The package type and pin count for given part number (to be found in table on page 10)
- The delivery form (Tape, Tray) depending on the selected package

Examples:

- EM6819F6-B300-TP028BD
- EM6819F4-B300-LF020D

Part Number

Refer to table on page 10 for the different part numbers
I.e EM6819F6-B300

Package Type and package pin count

Refer to table on page 10 for available packages for a given part number.

Packages: QFN, TSSOP

Pincounts: 16, 20, 28

Package and pincount codes:

QFN: LF020

TSSOP: TP028
TP020
TP016

Delivery Form

The delivery form depends on the selected package type

For TSSOP packages

- BD Tape and Real

For QFN packages

- D Tray

Die/wafer form delivery

Delivery in die or wafer form is also possible. Please contact EM Microelectronic directly if such delivery is requested.

EM Microelectronic-Marlin SA ("EM") makes no warranties for the use of EM products, other than those expressly contained in EM's applicable General Terms of Sale, located at <http://www.emmicroelectronic.com>. EM assumes no responsibility for any errors which may have crept into this document, reserves the right to change devices or specifications detailed herein at any time without notice, and does not make any commitment to update the information contained herein.

No licenses to patents or other intellectual property rights of EM are granted in connection with the sale of EM products, neither expressly nor implicitly.

In respect of the intended use of EM products by customer, customer is solely responsible for observing existing patents and other intellectual property rights of third parties and for obtaining, as the case may be, the necessary licenses.

Important note: The use of EM products as components in medical devices and/or medical applications, including but not limited to, safety and life supporting systems, where malfunction of such EM products might result in damage to and/or injury or death of persons is expressly prohibited, as EM products are neither destined nor qualified for use as components in such medical devices and/or medical applications. The prohibited use of EM products in such medical devices and/or medical applications is exclusively at the risk of the customer.