

# GPD

GAP 500    GAP 1000  
GAP 2000    GAP 3000  
                  GAP 5000

*OPTOELECTRONICS CORP.*

---

## Large Area InGaAs Photodiodes

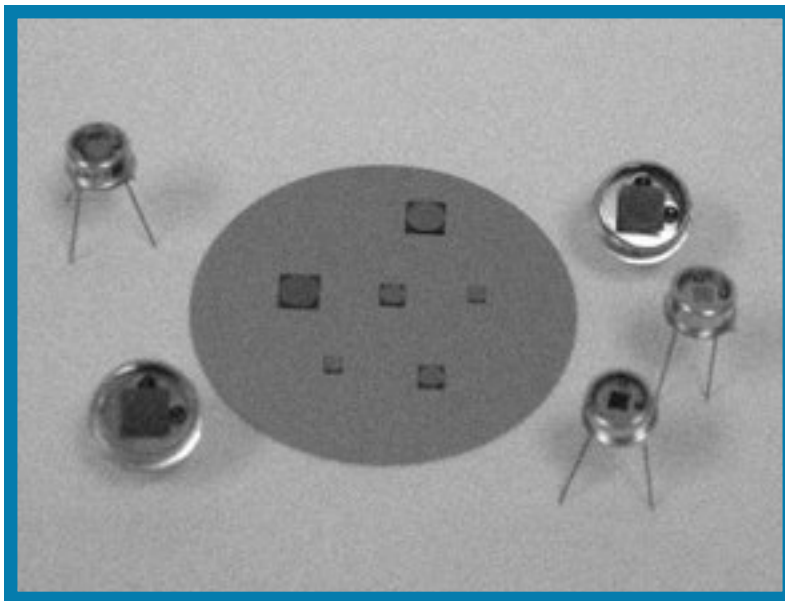

- **High Responsivity**
- **High Shunt Resistance**
- **Low Capacitance: High Speed**
- **Planar Design for High Reliability**

---

GPD Optoelectronics Corp.



### Electrical Characteristics @ 25 °C

	GAP500	GAP1000	GAP2000	GAP3000	GAP5000
Active Diameter (mm.)	0.5	1.0	2.0	3.0	5.0
Responsivity @ 850nm	0.10 (0.20)	0.10 (0.20)	0.10 (0.20)	0.10 (0.20)	0.10 (0.20)
A/W min. (typ.)1300nm	0.80 (0.90)	0.80 (0.90)	0.80 (0.90)	0.80 (0.90)	0.80 (0.90)
1550nm	0.95	0.95	0.95	0.95	0.95
Dark Current nA max. (typ.)	30 (6)@5V	100 (25)@5V	200 (50)@1V	500 (200)@1V	10μA(5μA)@0.3V
C <sub>i</sub> @ 0V pF max (typ.)	40 (20)	120 (80)	500 (300)	1000 (600)	1500 (1000)
C <sub>i</sub> @ -5V pF max (typ.)	10 (8)	50(30)	150(100)@-3V	300(250)@-2V	n/a
Bandwidth 50 Ω -3dB	200 (5V)	40(5V)	5.3 (0V)	4.0(0V)	1.0(0V)
T <sub>r</sub> R <sub>L</sub> =50Ω ns (typ.)	2.5 (5V)	5.0 (5V)	50 (0V)	100 (0V)	300(0V)
R <sub>s</sub> MΩ min (typ.)	50 (125)	10 (50)	6 (30)	2.0 (8)	25KΩ (50KΩ)
NEP (1550 nm)pW/√Hz min.	.008	.01	.03	.05	0.28
Linear range (±0.2dB) dBm	+10	+10	+8	+8	+8
Case Style (standard)	TO-46 (mod.)	TO-46 (mod.)	TO-5	TO-5	TO-8

### Maximum Ratings

	GAP500	GAP1000	GAP2000	GAP3000	GAP5000
Storage Temperature °C	-40 to 125	-40 to 125	-40 to 125	-40 to 125	-40 to 125
Operating Temperature °C	-40 to 85	-40 to 85	-40 to 85	-40 to 85	-40 to 85
Reverse Voltage V	20	20	3	2	2
Reverse Current mA	10	10	10	10	10
Forward Current mA	10	10	10	10	10
Power Dissipation mW	100	100	50	50	50



GAP 500    GAP 1000  
GAP 2000    GAP 3000  
GAP 5000

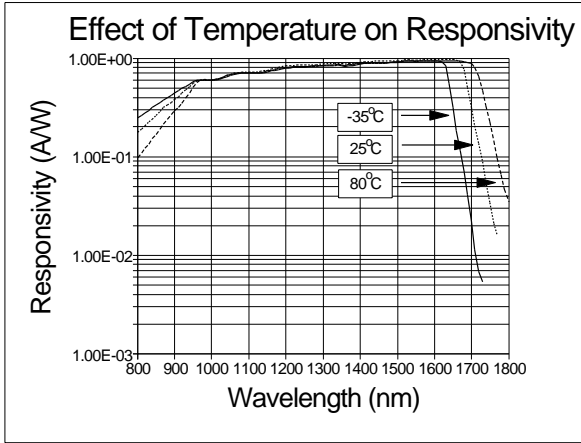

### Plot of Surface Response for GAP 2000 at 1300 nm

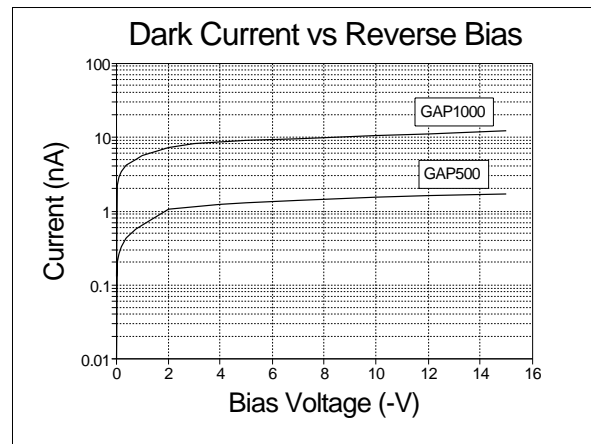
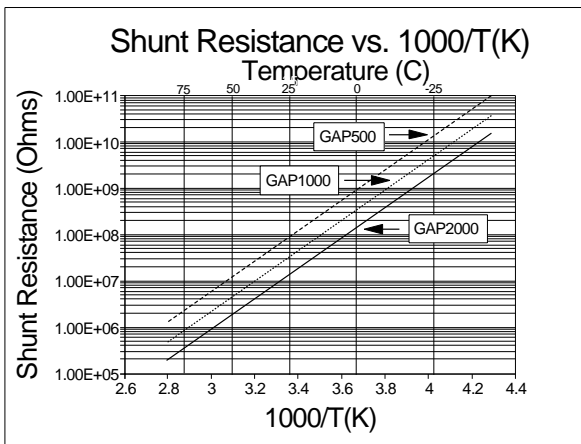
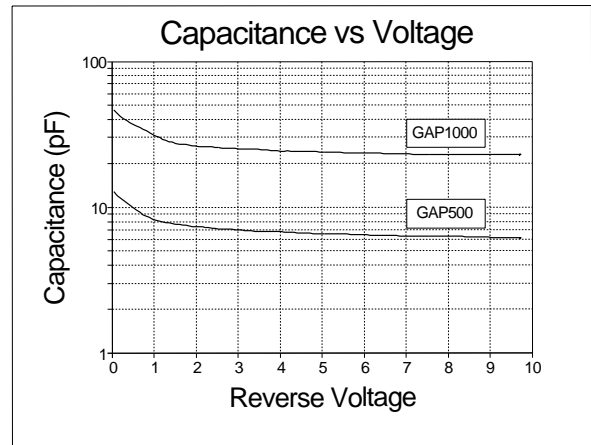
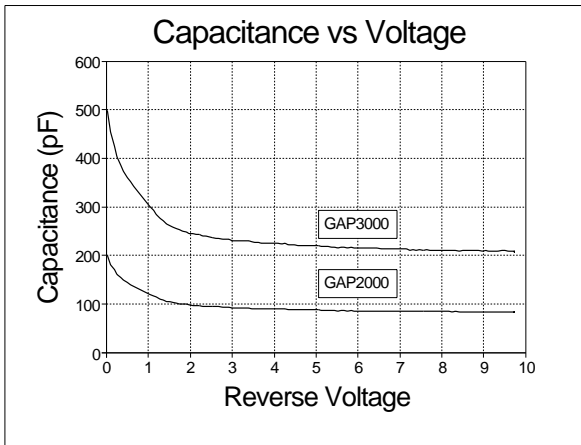
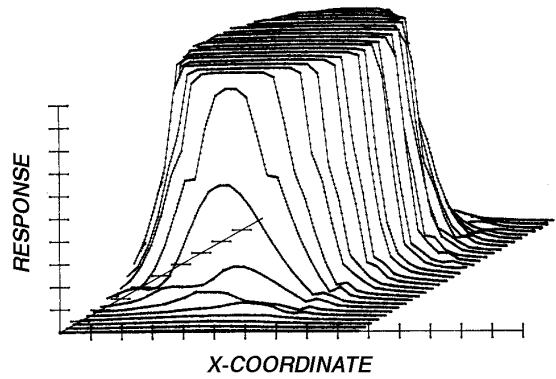

Extended short-wavelength response also available.

**GPD Optoelectronics Corp.**



GAP 500    GAP 1000  
GAP 2000    GAP 3000  
GAP 5000

## Package Outlines

Dimensions in mm (in.) Many other packages (including lensed packages) available.

### TO-46 (modified)

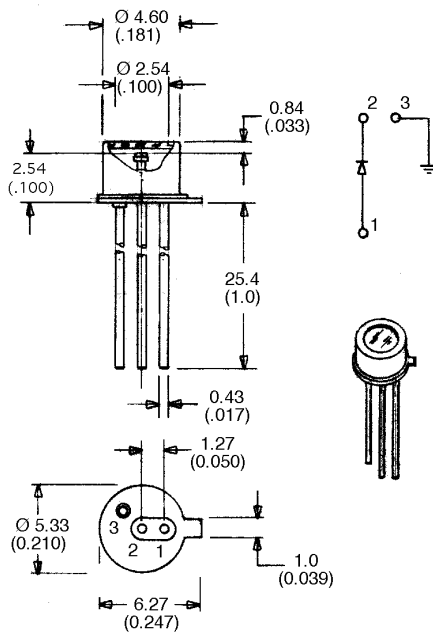

### TO-5

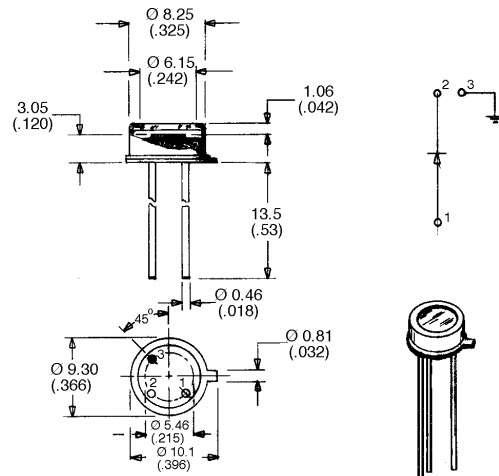

GPD Optoelectronics Corp. (formerly Germanium Power Devices) has been a manufacturer of power transistors and diodes since 1973 and a manufacturer of infrared photodetectors for more than ten years. GPD offers Germanium p-n, p-i-n, APD and InGaAs p-i-n high-speed and large area photodetectors for infrared radiation detection and telecommunications applications. GPD can offer you a photodetector that meets your technical and cost requirements.

GPD maintains an inspection system in accordance with MIL-I-45208. Photodiodes are subjected to Bellcore testing requirements (TA-NWT-00093), MIL-STD-883 test methods and/or customer specifications.

**GPD Optoelectronics Corp.**  
7 Manor Parkway  
Salem, NH 03079-2842  
Tel: (603) 894-6865 Fax: (603) 894-6866  
E-mail address: sales@gpd-ir.com  
Web Site: <http://www.gpd-ir.com>