

# KOI-6102BS

## Features

### ► Infrared Data Features

- Small footprint surface mount package
- No shield case : 1.60 H x 2.70 W x 7.00 L
- Operating Voltage(Vcc) from 2.4 V to 3.6 V
- Low Shutdown current below 4nA (typ.)
- Built-in " stuck at one" LED Protection
- Typical link distance up to 1m
- Lead-free & High reliability package

### ► Remote Control Features

- Wide beam angle and high radiant intensity for remote control
- Typical link distance up to 8m

## Applications

- Cellular Phones(both CDMA & GSM based)
- PDAs, PDA Phones, Smart Phones
- POS Terminals(ex. IrFM dongles)
- Tablet, Notebook, Desktop PCs
- Portable Printers(for photos of Camera Phones), Inkjet & Laser Printers
- Digital Cameras
- KIOSKs, Vending Machines, ATMs
- Handheld devices for remote control function

### ■ Block Diagram

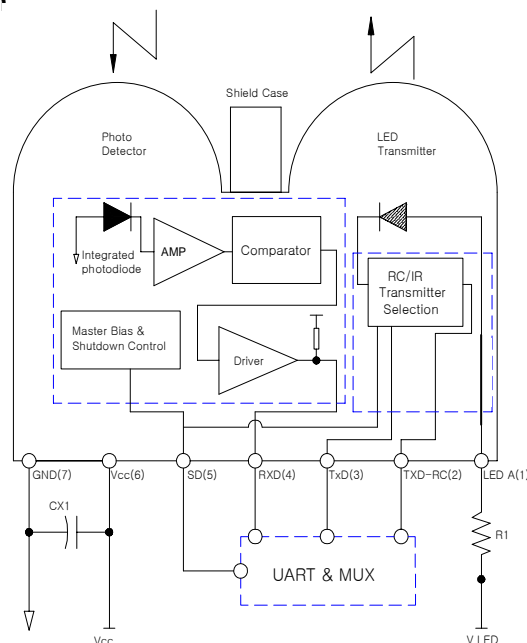

## Dimensions

(Unit : mm)

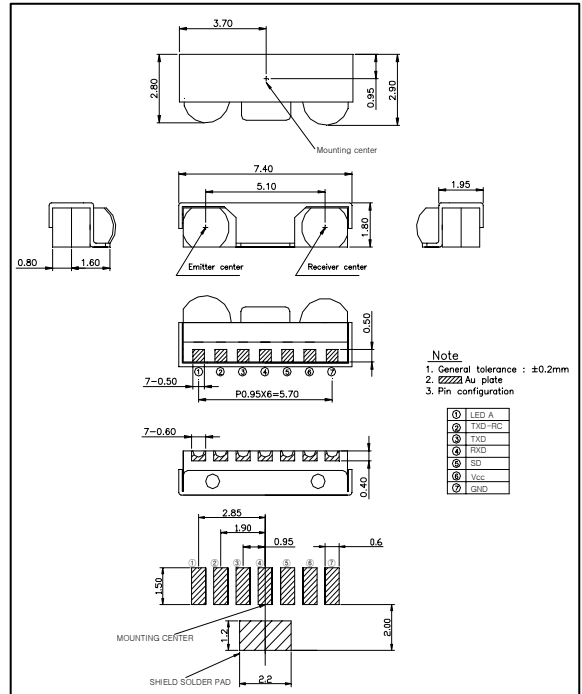

## KOI-6102BS

### Absolute Maximum Ratings

[Ta = 25°C]

Parameter	Symbol	Conditions	Min.	Max.	Unit
Supply Voltage	V <sub>CC</sub>	-	0	7.0	V
LED Supply Voltage	V <sub>LED</sub>	-	0	7.0	V
Operating Temperature	T <sub>opr.</sub>	-	-25	85	°C
Storage Temperature	T <sub>stg.</sub>	-	-40	100	°C
DC LED Transmit Current	I <sub>LED</sub> (DC)	V <sub>LED</sub> =V <sub>CC</sub> = 3.0V	-	50	mA
Peak LED Transmit Current	I <sub>LED</sub> (PK)	<90µs pulse width, <20% duty cycle	-	250	mA
DC LED Transmit Current ( IrRC)	I <sub>LED</sub> (DC)	V <sub>LED</sub> =V <sub>CC</sub> = 3.0V	-	75	mA
Peak LED Transmit Current	I <sub>LED</sub> (PK)	Remote Control Mode	-	400	mA
Receiver Data Output Voltage	V <sub>RXD</sub>	-	-0.5	V <sub>CC</sub> +0.5	V
Transmitter Data Input Voltage	V <sub>TXD</sub>	-	-0.5	V <sub>CC</sub> +0.5	V

### Electro-Optical Characteristics

[Ta=25 °C , V<sub>CC</sub>=3.3V]

Parameter	Symbol	Conditions	Min.	Typ.	Max.	Unit	
Supply Current	I <sub>CC1</sub>	Shutdown	-	0.001	0.5	µA	
	I <sub>CC2</sub>	Idle	-	140	200	µA	
	I <sub>CC3</sub>	Active Receiver	-	170	800	µA	
Transmitter	TXD Hold Time	T <sub>h</sub>	-	25.0	-	ns	
	TXD Setup Time	T <sub>s</sub>	-	25.0	-	ns	
	TXD Pulse Width	T <sub>w</sub>	-	25.0	-	ns	
	Shutdown Pulse Width	T <sub>sd</sub>	-	25.0	-	ns	
	TXD Wakeup Time	T <sub>tw</sub>	-	-	15.0	20	µs
	Viewing Angle	2θ <sub>1/2</sub>	-	30	-	60	deg.
	Data Output Pulse Width	T <sub>stp</sub> w	tpw(TXD)=1.63µs at 115.2kbit/s	1.5	1.9	2.0	µs
	Rise Time	tr	tpw(TXD)=1.63µs at 115.2kbit/s	-	50	100	ns
	Fall Time	tf		-	100	150	ns
	Radiant Intensity (IrDA Mode)	IE1	R1 = 4.7Ω	5	8	-	mW/sr
	Radiant Intensity (RC Mode)	IE2	R1 = 4.7Ω	-	12	-	mW/sr
	Peak Emission Wavelength	λ <sub>P</sub>	-	-	875	-	nm
	Spectral Bandwidth	Δλ	-	-	45	-	nm
Receiver	Viewing Angle	2θ <sub>1/2</sub>	-	30	-	60	deg.
	Peak Sensitivity Wavelength	λ <sub>P</sub>	-	-	880	-	nm
	High Level Output Voltage	V <sub>OH</sub>	I <sub>OH</sub> =-200 µA	2/3 V <sub>IO</sub>	-	V <sub>CC</sub>	V
	Low Level Output Voltage	V <sub>OL</sub>	I <sub>OL</sub> =200 µA	-	-	1/3 V <sub>IO</sub>	V
	Rx SIR Pulse Width	T <sub>sr</sub> pw	tpw(TxD)=1.63µs at 115.2kbit/s	1.4	2.2	4.0	µs
	Rise Time	tr	tpw(TXD)=1.63µs at 115.2kbit/s	-	50	100	ns
	Fall Time	tf		-	50	100	ns
	Communication Distance (SIR)	D		0.3	0.6	-	m
	Receiver Latency Time	TL	-	-	60	200	µs
Receiver Wakeup Time	T <sub>rw</sub>	-	-	50	100	µs	