

KOI-6210A

Features

- Compliant to IrDA 1.4 Low Power Standard
- Wide Voltage Operation : 2.4 ~ 3.6V
- Compact Package Integrated Transmitter and Receiver (8.0L x 2.75W x 2.5T)
- Complete Power Down Mode for the Current Consumption.
- LED Stuck-high Protection
- Lead-free & High reliability package

Applications

- Cellular Phone
- Personal Computer(Desk-top PC, Lap-top PC)
- Printers, Vending Machine, ATM
- Personal Digital Assistants.(PDA)

Dimensions

(Unit : mm)

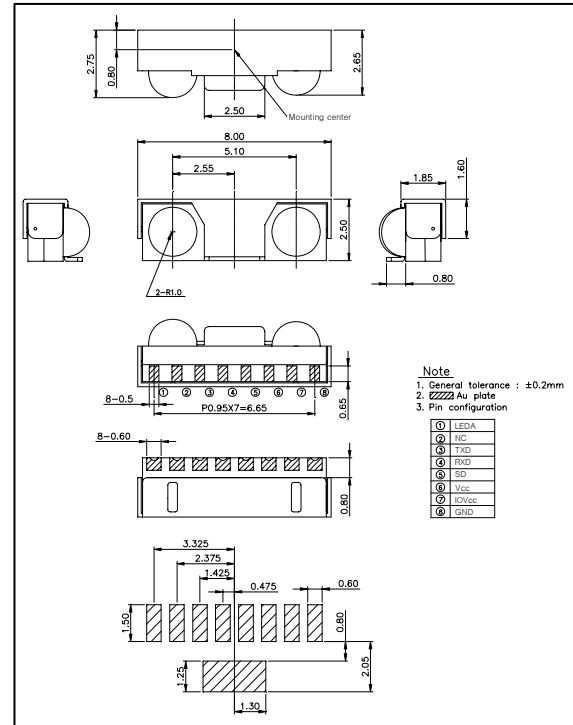

Block Diagram

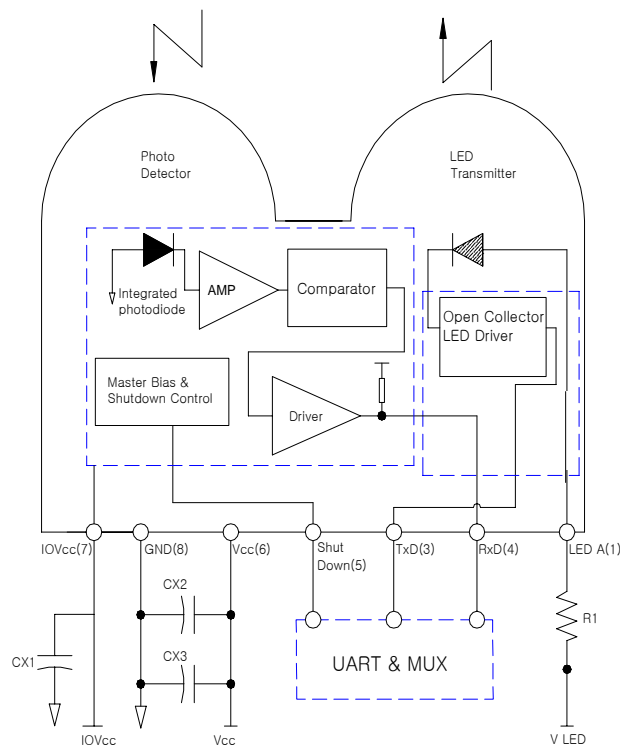

KOI-6210A

Absolute Maximum Ratings

[Ta = 25 °C]

Parameter	Symbol	Conditions	Min.	Max.	Unit
Supply Voltage	V _{CC}	-	0	6.5	V
LED Supply Voltage	V _{LED}	-	0	6.5	V
Operating Temperature	T _{opr.}	-	-25	85	°C
Storage Temperature	T _{stg.}	-	-40	100	°C
DC LED Transmit Current	I _{LED (DC)}	-	-	50	mA
Peak LED Transmit Current	I _{LED (PK)}	<90µs pulse width, <20% duty cycle	-	300	mA
Receiver Data Output Voltage	V _{RxD}	-	-0.5	V _{CC} +0.5	V
Transmitter Data Input Voltage	V _{TxD}	-	-0.5	V _{CC} +0.5	V

4. Electro-Optical Characteristics

[Ta=25 °C, V_{CC}=3.3V]

Parameter	Symbol	Conditions	Min.	Typ.	Max.	Unit	
Supply Current	I _{cc1}	Shutdown	-	0.5	1	µA	
	I _{cc2}	Idle	-	2.3	3.0	mA	
Transmitter	Transmitter Wakeup Time	T _{tw}	-	30	200	µs	
	Viewing Angle	2θ _{1/2}	-	30	-	60	deg.
	Data Output Pulse Width	T _{stpw}	tpw(TxD)=1.63µs at 115.2kbit/s	1.6	1.7	1.9	µs
			tpw(TxD)=125ns at 4Mbit/s	105	125	145	ns
	Rise Time	t _r	BR=115.2kbit/s	-	100	600	ns
	Fall Time	t _f	BR=115.2kbit/s	-	100	600	ns
	Peak Emission Wavelength	λ _p	-	-	875	-	nm
Spectral Bandwidth	Δλ	-	-	45	-	nm	
Receiver	Viewing Angle	2θ _{1/2}	-	30	-	-	deg.
	Peak Sensitivity Wavelength	λ _p	-	-	880	-	nm
	High Level Output Voltage	V _{OH}	I _{OH} =-200µA	2/3V _{CC}	-	V _{CC}	V
	Low Level Output Voltage	V _{OL}	I _{OL} =200µA	-	-	1/3V _{CC}	V
	Rx SIR Pulse Width	T _{srpw}	tpw(TxD)=1.63µs at 115.2kbit/s	1.0	2.2	4	µs
	Rx SIR Pulse Width	T _{srpw}	tpw(TxD)=125ns at 4Mbit/s	80	130	175	ns
	Rise Time	t _r	BR=115.2kbit/s	-	100	600	ns
	Fall Time	t _f	BR=115.2kbit/s	-	100	600	ns
	Communication Distance	D	tpw(TxD)=1.63µs at 115.2kbit/s	40	60	-	cm
	Receiver Latency Time	TL		-	50	100	µs
	Receiver Wakeup Time	T _{rw}		-	70	200	µs