

# KOI-6713B

## Features

- Compliant to IrDA 1.4 Low Power Standard
- Operating Voltage : 2.4 ~ 3.6V
- Compact Package Integrated Transmitter and Receiver (7.0L x 2.70W x 1.3T)
- Complete Power Down Mode for the Current Consumption.
- LED Stuck-high Protection
- Lead-free & High reliability package

## Remote Control Features

- Wide Beam angle and high radiant intensity for remote control
- Typical link distance up to 8m

## Applications

- Cellular Phone
- Personal Computer(Desk-top PC, Lap-top PC)
- Printers, Vending Machine, ATM
- Personal Digital Assistants.(PDA)

## Dimensions

(Unit : mm)

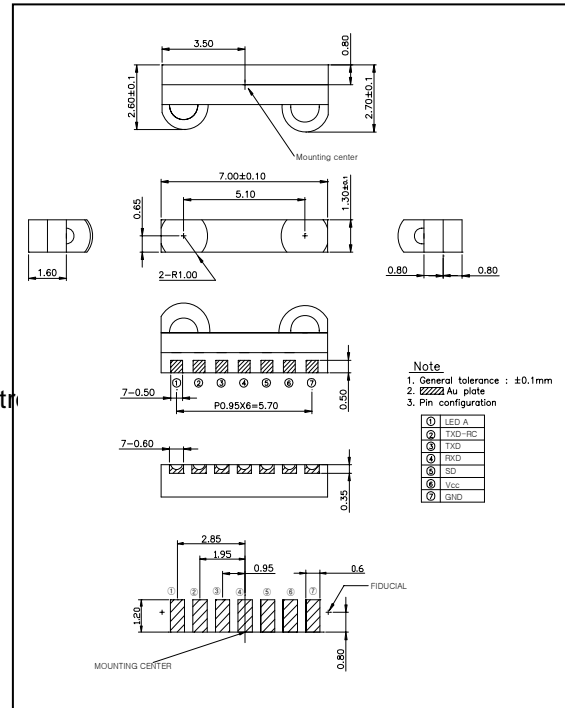

## Block Diagram

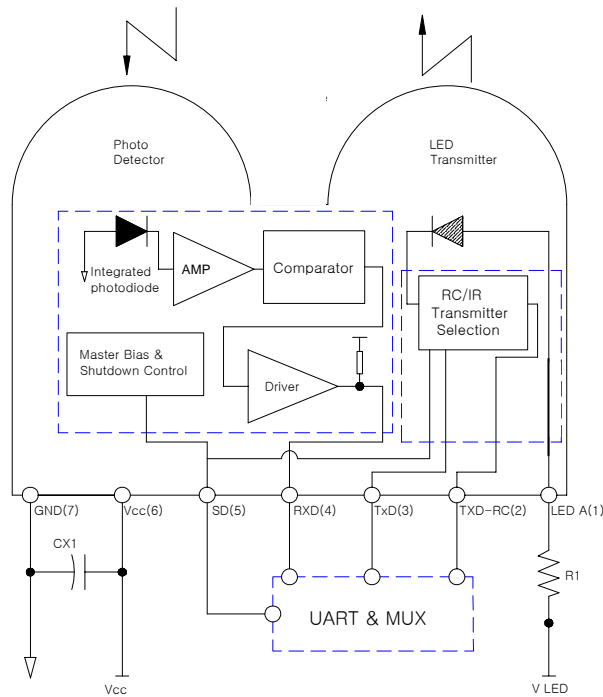

# KOI-6713B

## Absolute Maximum Ratings

[Ta = 25 °C ]

Parameter	Symbol	Conditions	Min.	Max.	Unit
Supply Voltage	V <sub>CC</sub>	-	0	7.0	V
LED Supply Voltage	V <sub>LED</sub>	-	0	7.0	V
Operating Temperature	T <sub>opr.</sub>	-	-25	85	°C
Storage Temperature	T <sub>stg.</sub>	-	-40	100	°C
DC LED Transmit Current	I <sub>LED (DC)</sub>	-	-	50	mA
Peak LED Transmit Current	I <sub>LED (PK)</sub>	<90µs pulse width, <20% duty cycle	-	200	mA
Peak LED Transmit Current	I <sub>LED (PK)</sub>	Remote control Mode	-	300	mA
Receiver Data Output Voltage	V <sub>RxD</sub>	-	-0.5	V <sub>CC</sub> +0.5	V
Transmitter Data Input Voltage	V <sub>TxD</sub>	-	-0.5	V <sub>CC</sub> +0.5	V

## 4. Electro-Optical Characteristics

[Ta=25 °C, V<sub>CC</sub>=3.3V]

Parameter	Symbol	Conditions	Min.	Typ.	Max.	Unit	
Supply Current	I <sub>CC1</sub>	Shutdown	-	0.001	0.5	µA	
	I <sub>CC2</sub>	Idle	-	140	200	µA	
Transmitter	T <sub>XD</sub> Hold Time		25	-	-	µs	
	T <sub>XD</sub> Setup Time		25	-	-	µs	
	T <sub>XD</sub> Pulse Width		25	-	-	µs	
	Shutdown Pulse Width		25	-	-	µs	
	T <sub>XD</sub> Wakeup Time	T <sub>tw</sub>		-	15	20	µs
	Viewing Angle	2θ <sub>1/2</sub>	-	30	-	60	deg.
	Data Output Pulse Width	T <sub>stpw</sub>	tpw(RxD)=1.63µs at 115.2kbit/s	1.5	1.9	2.0	µs
	Rise Time	t <sub>r</sub>	BR=115.2kbit/s	-	50	100	ns
	Fall Time	t <sub>f</sub>		-	100	150	ns
	Peak Emission Wavelength	λ <sub>p</sub>	-	-	875	-	nm
	Spectral Bandwidth	Δλ	-	-	45	-	nm
Receiver	Viewing Angle	2θ <sub>1/2</sub>	-	30	-	60	deg.
	Peak Sensitivity Wavelength	λ <sub>p</sub>	-	-	880	-	nm
	High Level Output Voltage	V <sub>OH</sub>	I <sub>OH</sub> =-200 µA	2/3 V <sub>CC</sub>	-	V <sub>CC</sub>	V
	Low Level Output Voltage	V <sub>OL</sub>	I <sub>OL</sub> =200 µA	-	-	1/3 V <sub>CC</sub>	V
	Rx SIR Pulse Width	T <sub>srpw</sub>	tpw(RxD)=1.63µs at 115.2kbit/s	1.4	2.2	4	µs
	Rise Time	t <sub>r</sub>	BR=115.2kbit/s	-	50	100	ns
	Fall Time	t <sub>f</sub>		-	50	100	ns
	Communication Distance	D		30	60	-	cm
	Receiver Latency Time	T <sub>L</sub>		-	60	200	µs
Receiver Wakeup Time	T <sub>rw</sub>		-	50	100	µs	