

DAEP Decoder

■ General Description

The NJU26209 is a digital signal processor that provides the function of DAEP (Dolby Automotive Entertainment Program).

A location of sound image forward is possible without a center speaker by all seats in the car.

The applications of NJU26209 are suitable for Car Audio, Car Navigation system and other audio products.

■ Package



NJU26209V

■ Features

-Software

- DAEP (Dolby Automotive Entertainment Program)
 - Pro Logic II
 - Automotive (Advanced Surround Fader, Center Image Control)
 - Bass Management
 - Time Alignment
- Master Volume
- Input Trim
- Channel Trim

-Hardware

- 24bit Fixed-point Digital Signal Processing
- Maximum Clock Frequency : 12.288MHz(Standard), built-in PLL Circuit
- Digital Audio Interface : 4 Input ports / 4 Output ports
- Digital Audio Format : I²S 24bit, left-justified, right-justified, BCK : 32fs/64fs
- Master / Slave Mode
- Microcomputer Interface
 - I²C Bus (Standard-mode/100kbps, Fast-mode/400kbps)
 - 4-Wire Serial Bus (4-Wire: Clock, Enable, Input data, Output data)
- Operating Voltage : V_{DD} = V_{DDPLL} = 1.8V
: V_{DDIO} = 3.3V
- Input Terminal : +5.0V Input tolerant
- Package : SSOP44 (Pb-Free)

* The detail hardware specification of the NJU26209 is described in the "NJU26200 Series Hardware Data Sheet".

■ Hardware Block Diagram

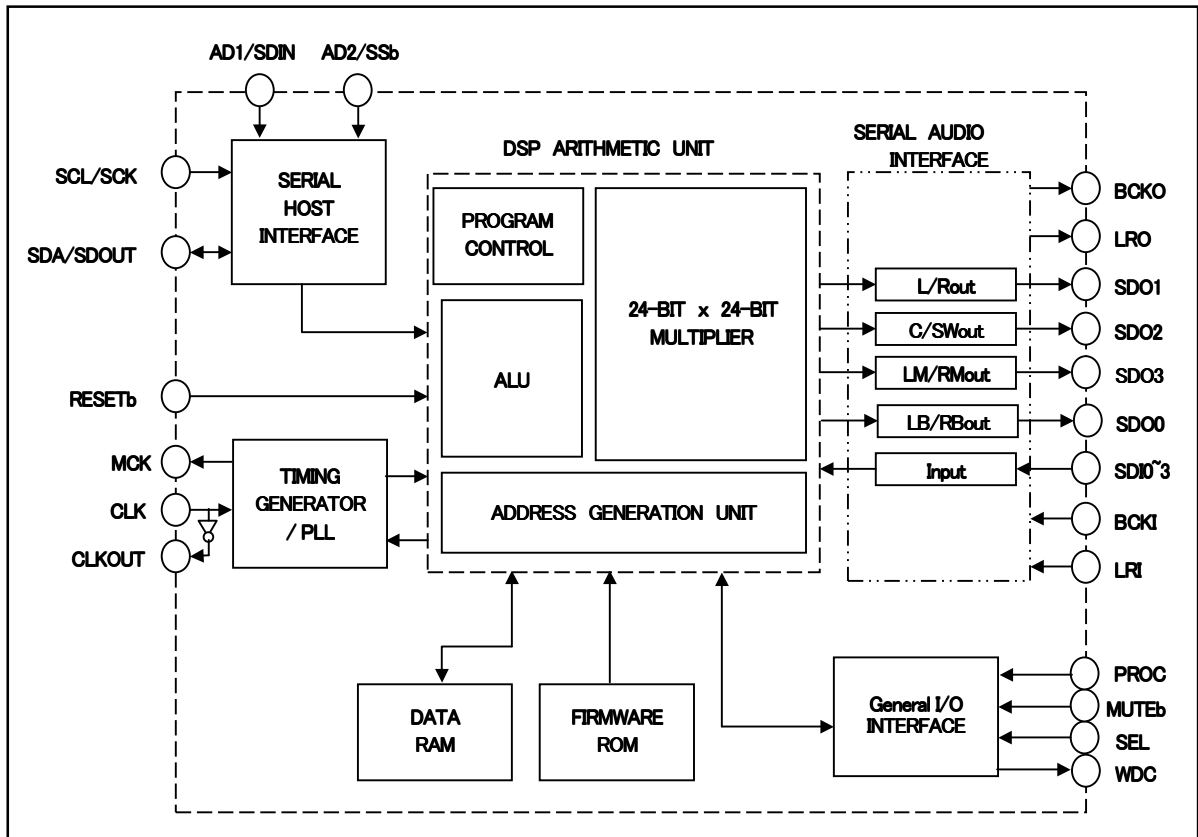

Fig. 1 NJU26209 Hardware Block Diagram

■ Function Block Diagram

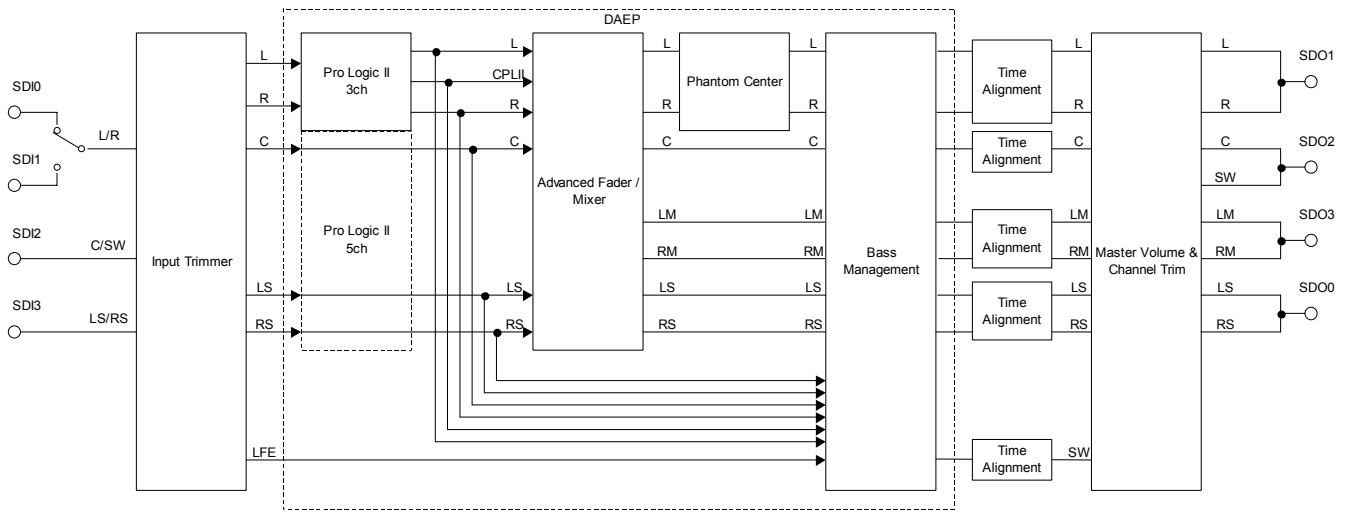

Fig. 2 Function Block Diagram (Firmware)

■ Pin Configuration

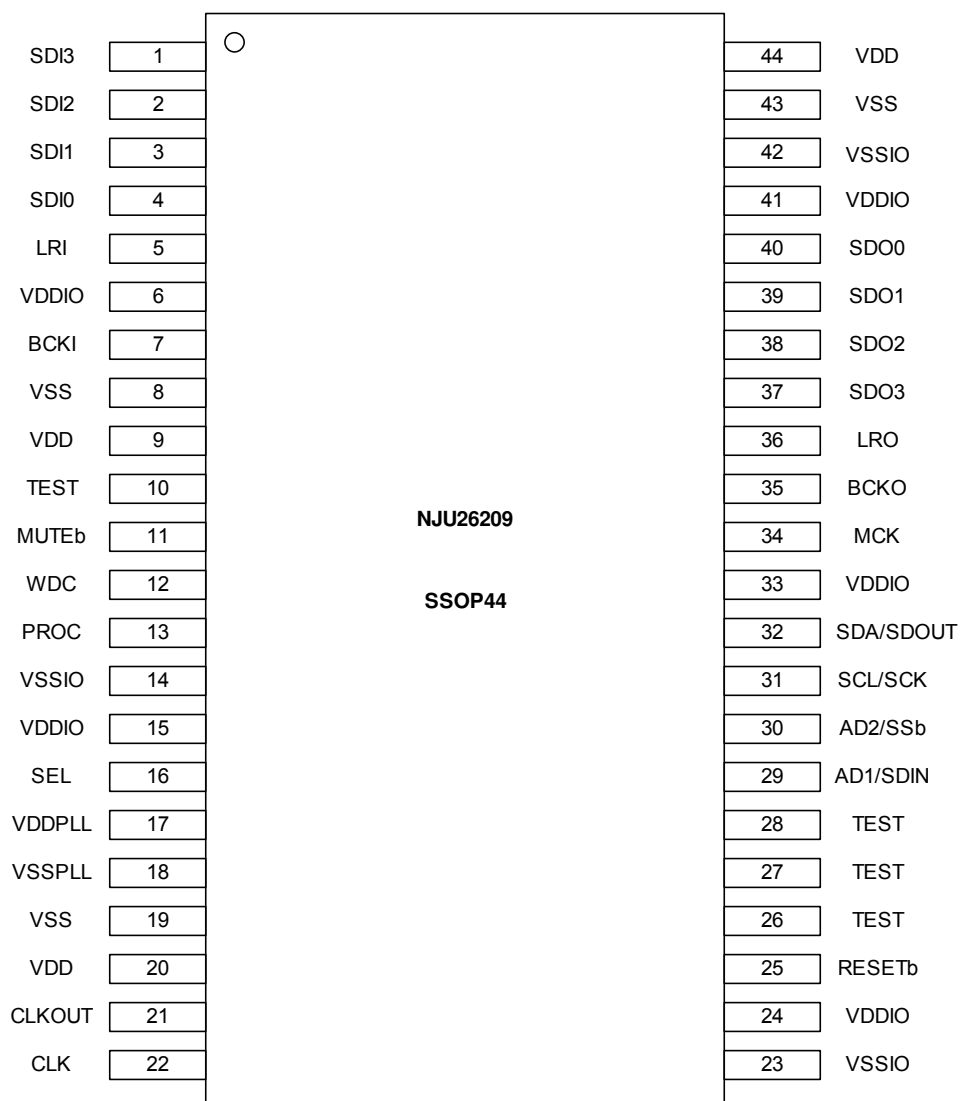

Fig. 3 NJU26209 Pin Configuration

■ Pin Description

Table 1 Pin Description

Pin No.	Symbol	I/O	Function
1	SDI3	I	Audio Data Input ch.3 (LS/RS)
2	SDI2	I	Audio Data Input ch.2 (C/SW)
3	SDI1	I	Audio Data Input ch.1 (L/R)
4	SDI0	I	Audio Data Input ch.0 (L/R)
5	LRI	I	LR Clock Input
6	VDDIO	-	I/O Power Supply +3.3V
7	BCKI	I	Bit Clock Input
8	VSS	-	DSP Core Power Supply GND
9	VDD	-	DSP Core Power Supply +1.8V
10	TEST *	I	for test connect with VSSIO through 3.3-ohm resistance.
11	MUTEb *	I	Master Volume Status after reset '1': 0dB, '0': Mute
12	WDC *	OD	Watchdog Clock output pin (Open drain output)
13	PROC *	I	Signal Processing after reset '1': Normal Processing, '0': Waiting for a Command without Processing
14	VSSIO	-	I/O Power Supply GND
15	VDDIO	-	I/O Power Supply +3.3V
16	SEL	I	Host Interface Selection '1': Serial Interface, '0': I ² C bus
17	VDDPLL	-	PLL Power Supply +1.8V
18	VSSPLL	-	PLL Power Supply GND
19	VSS	-	DSP Core Power Supply GND
20	VDD	-	DSP Core Power Supply +1.8V
21	CLKOUT	O	OSC Clock Output
22	CLK	I	OSC Clock Input (12.288MHz)
23	VSSIO	-	I/O Power Supply GND
24	VDDIO	-	I/O Power Supply +3.3V
25	RESE Tb	I	Reset (RESE Tb='0': DSP Reset)
26	TEST	I	for test (connect to VDDIO)
27	TEST	I	for test (connect to VSSIO)
28	TEST	I	for test (connect to VSSIO)
29	AD1/SDIN	I	I ² C Address (I ² C mode) / Serial In (4-wire serial mode)
30	AD2/SSb	I	I ² C Address (I ² C mode) / Serial enable (4-wire serial mode)
31	SCL/SCK	I	I ² C SCL (I ² C mode) / Serial clock (4-wire serial mode)
32	SDA/SDOUT	I/O	I ² C SDA (I ² C mode) / Serial Out (4-wire serial mode)
33	VDDIO	-	I/O Power Supply +3.3V
34	MCK	O	A/D, D/A clock output (buffer output of a CLK pin)
35	BCKO	O	Bit Clock Output
36	LRO	O	LR Clock Output
37	SDO3	O	Audio Data Output ch.3 (LM/RM)
38	SDO2	O	Audio Data Output ch.2 (C/SW)
39	SDO1	O	Audio Data Output ch.1 (L/R)
40	SDO0	O	Audio Data Output ch.0 (LS/RS)
41	VDDIO	-	I/O Power Supply +3.3V
42	VSSIO	-	I/O Power Supply GND
43	VSS	-	DSP Core Power Supply GND
44	VDD	-	DSP Core Power Supply +1.8V

Note : I : Input

O : Output

OD : Open Drain Output

I/O : Bi-directional

Pins symbol with * : Connect with VDDIO or VSSIO through 3.3kΩ resistance

■ Audio Interface

The NJU26209 audio interface provides industry serial data formats of I²S, MSB-first Left-justified or MSB-first Right-justified. The NJU26209 audio interface provides four data inputs, SDI0, SDI1, SDI2 and SDI3, and four data outputs, SDO0, SDO1, SDO2 and SDO3 as shown in table 2 and 3. The input serial data is selected by the firmware command.

Table 2 Serial Audio Input Pin

Pin No.	Symbol	Description	
		Stereo input	Multi channel input
4	SDI0	Audio Data Input (L/R)	Audio Data Input (L/R)
3	SDI1	(SDI0/SDI1 pin select)	(SDI0/SDI1 pin select)
2	SDI2	None	Audio Data Input 2 (C/SW)
1	SDI3	None	Audio Data Input 3 (LS/RS)

Table 3 Serial Audio Output Pin

Pin No.	Symbol	Description
40	SDO0	Audio Data Output 0 (LS/RS)
39	SDO1	Audio Data Output 1 (L/R)
38	SDO2	Audio Data Output 2 (C/SW)
37	SDO3	Audio Data Output 3 (LM/RM)

■ Host Interface

The NJU26209 can be controlled via Serial Host Interface (SHI) using either of two serial bus formats : I²C bus or 4-Wire serial bus. Data transfers are in 8 bits packets (1 byte) when using either format. The SHI operates only in a SLAVE fashion. A host controller connected to the interface always drives the clock (SCL / SCK) line and initiates data transfers, regardless of the chosen communication protocol.

The detail I²C bus and 4-Wire Serial bus information are described in the 'NJU26200 Series Hardware Data Sheet'.

Table 4 Serial Host Interface Pin Descriptions

Pin No.	Symbol	Setting	Host Interface
16	SEL	Low	I ² C Bus Interface
		High	4-Wire Serial Interface

Table 5 Serial Host Interface Pin Description

Pin No.	Symbol (I ² C /Serial)	I ² C bus Interface	4-Wire Serial Interface
29	AD1/SDIN	I ² C Address Select Bit1	Serial data input
30	AD2/SSb	I ² C Address Select Bit2	Slave select
31	SCL/SCK	Serial Clock	Serial Clock
32	SDA/SDOUT	Serial Data Input/Output (Open Drain output)	Serial data output (CMOS Output)

Note: When I²C Bus is selected, this pin is a bi-directional Open Drain output. This pin, which is assigned for I²C Bus, requires a pull-up resistance.

When 4-Wire Serial bus is selected, the SDA/SDOUT pin is CMOS output.

The SDA/SDOUT pin isn't 5.0V Input tolerant.

■ I²C Bus

When the NJU26209 is configured for I²C bus communication in SEL="Low", the serial host interface transfers data on the SDA pin and clocks data on the SCL pin. The SDA is an open drain pin requiring a pull-up resistance. Pins AD1 and AD2 are used to configure the seven-bit SLAVE address of the serial host interface. (Table 6)

Table 6 I²C Bus Interface Slave address

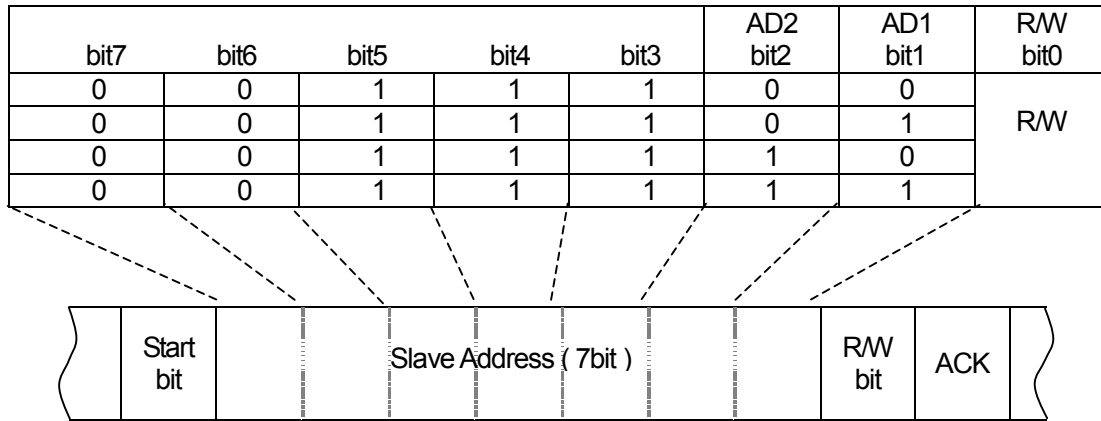

* SLAVE address is 0 when AD1/2 is "Low". SLAVE address is 1 when AD1/2 is "High".

* SLAVE address is 0 when RW is "W". SLAVE address is 1 when RW is "R".

Note:

Both "Standard-Mode (100kbps)" and "Fast-Mode (400kbps)" data transfer rate are supported.

■ 4-Wire Serial Interface

The serial host interface can be configured for 4-Wire Serial bus communication by setting SEL1="High" during the Reset Sequence initialization. SHI bus communication is full-duplex; a write byte is shifted into the SDIN pin at the same time that a read byte is shifted out of the SDOUT pin.

Data transfers are MSB first and are enabled by setting SSb = "Low". Data is clocked into SDIN on rising transitions of SCK. Data is latched at SDOUT on falling transitions of SCK except for the first byte(MSB) which is latched on the falling transitions of SSb. SDOUT is always CMOS output. SDOUT does not require a pull-up resistance.

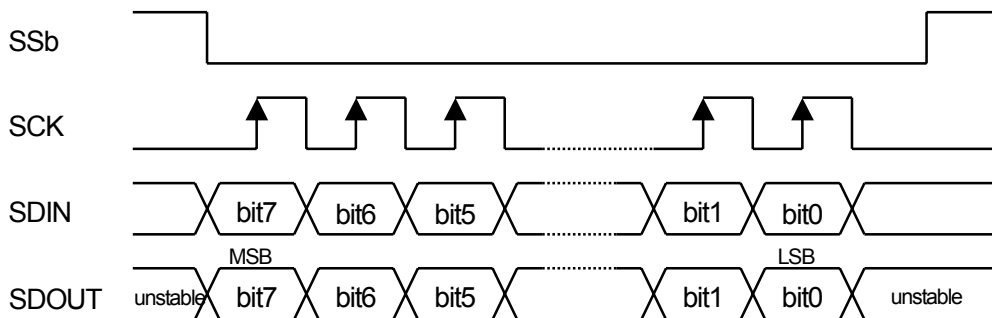

Fig. 4 4-Wire Serial Interface Timing

Note : When the data-clock is less than 8 clocks, the input data is shifted to LSB side and is sent to the DSP core at the transition of SSb="High".

When the data-clock is more than 8 clocks, the last 8 bit data becomes valid.

After sending LSB data, SDOUT transmits the MSB data which is received via SDIN until SSb becomes "High".

■ Pin setting

The NJU26209 operates default command setting after resetting the NJU26209. In addition, the NJU26209 restricts operation at power on by setting PROC pin and MUTEb pin. These pins are input pin. However, these pins operate as bi-directional pins. Connect with V_{DDIO} or V_{SSIO} through 3.3k Ω resistance.

Table 7 Pin setting

Pin No.	Symbol	Setting	Function
13	PROC	“High”	The NJU26209 operates default setting after reset.
		“Low”	The NJU26209 does not operate after reset. Sending start command is required for starting operation.
11	MUTEb	“High”	Master volume is set 0dB after reset.
		“Low”	Master volume is set mute after reset.

■ WatchDog Clock

The NJU26209 outputs clock pulse through WDC (Pin No.12) during normal operation. The WDC clock is useful to check the status of the NJU26209 operation. For example, a microcomputer monitors the WDC clock and checks the status of the NJU26209. When the WDC clock pulse is lost or not normal clock cycle, the NJU26209 does not operate correctly. Then reset the NJU26209 and set up the NJU26209 again. The WDC clock is able to be variable for 0msec to 100msec by command. Default setting of WDC clock is 100msec.

The WDC pin is open drain output. The WDC pin setting (Table 8)

Table 8 WDC pin setting

Pin No.	Symbol	Setting	
12	WDC	WDC pin is used.	Connect with V_{DDIO} through 3.3k Ω resistance.
		WDC pin is not used.	Connect with V_{SSIO} through 3.3k Ω resistance. Do not open WDC pin.

Note: The cycle of WDC output is rough. Because WDC output inserts in the process of sound processing. In slave mode, when there is no input of BCKI/LRI, WDC can't output. It is required to set up a sampling rate correctly.

■ Firmware Command Table

Host processor can control the NJU26209 via I²C bus or 4-Wire serial bus interface. The following table summarizes the available user commands.

Table 9 Command Table

No.	Command Description
1	Set Task Command
2	System State Command
3	Sample rate Select Command
4	Smooth Control Config Command
5	Master Volume Control Command
6	Channel Trim Control Command
7	Input Trim Control Command
8	DAEP Balance Control Command
9	DAEP Phantom Center Config Command
10	Pro Logic II Shelf Filter Config Command
11	Bass Management Config Command
12	Bass Management LFE Trim Command
13	Bass Management Center Trim Command
14	Bass Management L/R Trim Command
15	Bass Management LS/RS Trim Command
16	Front Delay Control Command
17	Middle Delay Control Command
18	Surround Delay Control Command
19	Center Delay Control Command
20	Subwoofer Delay Control Command
21	PNG Mode Command
22	Firmware Version Number Request Command
23	DSP Reset Command
24	Start Command
25	Nop Command

Notes : In respect to detail command information, request New Japan Radio Co., Ltd. and permission of a licenser (Dolby) is required.

■ Response of status

NJU26209 returns the response of 4 types to the host controller.

Table 10 Response of status

Response	Command	Remark
Status : Command Accepted	0x80	Reception OK
Status : Command Error	0x81	Reception ERROR
Status : Command Process	0x82	Command processing
Status : Not Ready	0x83	Initialization

■ License Information

The Word "DOLBY", "Pro Logic II", DAEP and the double D mark are trademarks of Dolby Laboratories.
The NJU26209 can only be delivered to licensees of Dolby Laboratories.
Please refer to the licensing application manual issued by Dolby Laboratories.

[CAUTION]
The specifications on this databook are only given for information, without any guarantee as regards either mistakes or omissions. The application circuits in this databook are described only to show representative usages of the product and not intended for the guarantee or permission of any right including the industrial rights.