

MONAURAL AUDIO POWER AMPLIFIER IC

■ GENERAL DESCRIPTION

The **NJM2166** are monaural power amplifier suitable for mobile communication equipment. It is possible to operate on low operating voltage such as 2.7V and incorporates mute function, suspend function and AUX input.

■ PACKAGE OUTLINE



NJM2166R



NJM2166V

■ FEATURES

- Operating Voltage (2.7V to 8.5V)
- AUX input
- Suspend Mode Function
- Mute Function
- EVR function
- Bipolar Technology
- Package outline SSOP14, VSP10

■ PIN CONFIGURATION

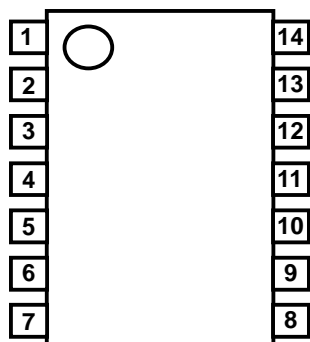

NJM2166V

No.	NAME	No.	NAME
1	V ⁺	8	NC
2	NC	9	EVR
3	SP-IN	10	BIAS
4	AUX	11	SPOUT-1
5	AM	12	SPOUT-2
6	SUSPEND	13	NC
7	NC	14	GND

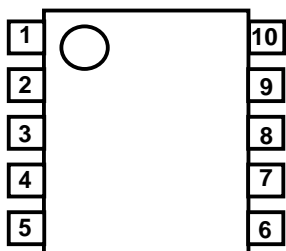

NJM2166R

No.	NAME	No.	NAME
1	V ⁺	6	EVR
2	SP-IN	7	BIAS
3	AUX	8	SPOUT-1
4	AM	9	SPOUT-2
5	SUSPEND	10	GND

■ BLOCK DIAGRAM

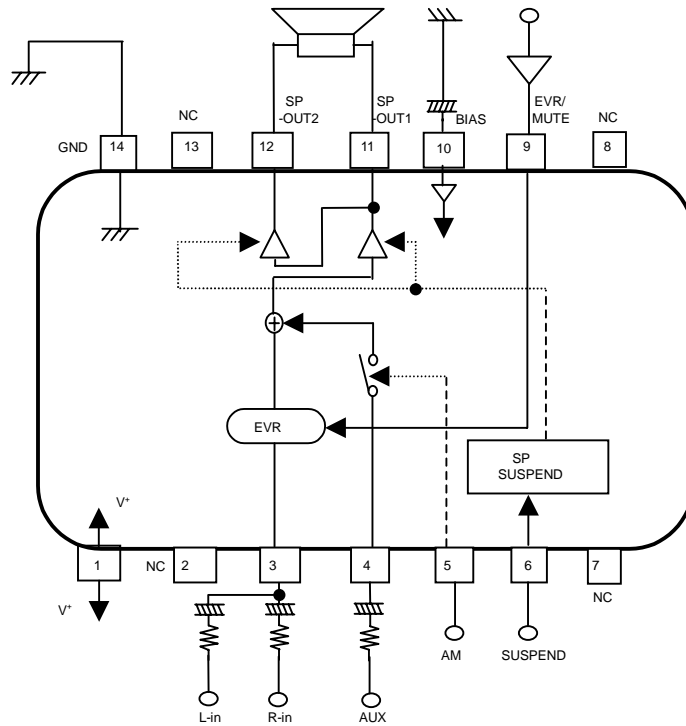

NJM2166V Block Diagram

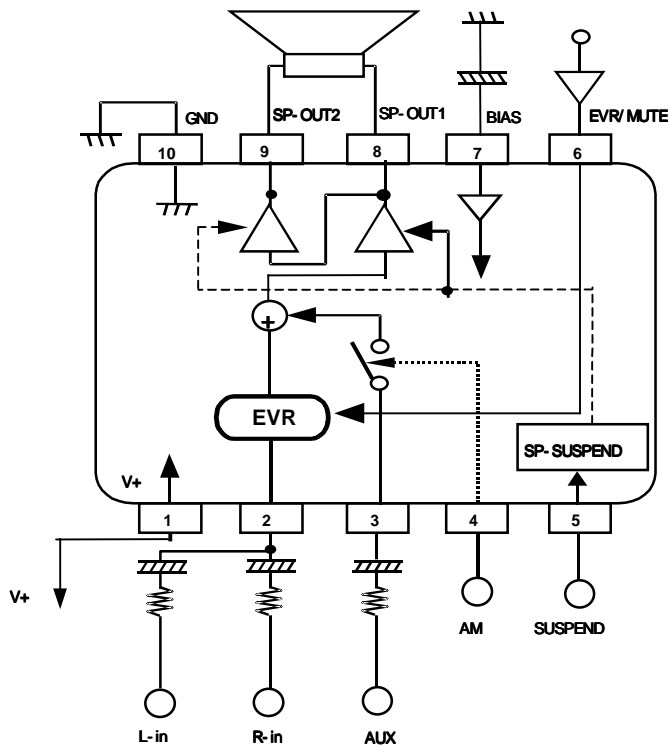

NJM2166R Block Diagram

■ ABSOLUTE MAXIMAM RATINGS (Ta=25°C)

PARAMETER	SYMBOL	RATINGS	UNIT
Supply Voltage	V ⁺	+9.0	V
Power Dissipation	P _D	(SSOP14) 300 (VSP10) 320	mW
Operating Temperature Range	Topr	-40 to +85	°C
Storage Temperature Range	Tstg	-50 to +150	°C

■ RECOMMENDATION OPERATING LIMITS (Ta=25°C)

	PARAMETER	SYMBOL	RATINGS	UNIT
Operating Voltage	Operating Voltage	V ⁺	+2.7 to +8.5	V

■ ELECTRICAL CHARACTERISTICS (V⁺=3.0V, Ta=25°C)
● OPERATING CURRENT

PARAMETER	TEST CONDITION	SYMBOL	MIN.	TYP.	MAX.	UNIT
Operating Current	No signal, V _{evr} =0.3V	I _q	2.0	2.5	3.5	mA
Operating Current SUSPEND	No signal, V _{SUS} =H	I _{qs}	100	150	200	μA

● SPEAKER AMP1

 (Input : SP IN, R_{INSP}=15kΩ)

PARAMETER	TEST CONDITION	SYMBOL	MIN.	TYP.	MAX.	UNIT
Output Voltage Level	V _{in} =-16.0dBV, R _L =8Ω	V _o	-6.5	-4.0	-1.5	dBV
Total Harmonic Distortion	V _{in} =-16.0dBV, R _L =8Ω	THD	-	0.9	1.8	%
Maximum Output Level1	R _L =8Ω, THD=3%, A-Weighted	V _{OM1}	-2.5	0.0	-	dBV
Maximum Output Level2	V ⁺ =5V, R _L =16Ω, THD=3%, A-Weighted	V _{OM2}	-4.5	7.0	-	dBV
Output Remain Noise	R _g =1kΩ, A-Weighted	V _{on}	-	-82	-75	dBV
Mute Level	V _{in} =-16dBV, V _{evr} =0.3V, A-Weighted	V _{OoffSP}	-	-78	-70	dBV

● SPEAKER AMP2

 (Input : AUX IN, R_{INAUX}=30kΩ)

PARAMETER	TEST CONDITION	SYMBOL	MIN.	TYP.	MAX.	UNIT
Output Level	V _{inAUX} =-16.0dBV, R _L =8Ω	V _{O AUX}	-12.5	-10.0	-7.5	dBV
AUX Mix Off Level	V _{inAUX} =-16.0dBV, V _{AM} =L, A-Weighted	V _{O OffAUX}	-	-78	-70	dBV

●CONTROL BLOCK
MUTE JUDGMENT LEVEL (EVR TERMINAL)

PARAMETER	TEST CONDITION	SYMBOL	MIN.	TYP.	MAX.	UNIT
MUTE ON		V _{MON}	-	GND-0.4	-	V
MUTE OFF		V _{MOFF}	-	0.4-V ⁺	-	V

SUSPEND CONTROL BLOCK (SUSPEND TERMINAL)

PARAMETER	TEST CONDITION	SYMBOL	MIN.	TYP.	MAX.	UNIT
SUSPEND ON		V _{SH}	1.5	-	V ⁺	V
SUSPEND OFF		V _{SL}	GND	-	0.4	V

AUX.MIX CONTROL BLOCK (AMTERMINAL)

PARAMETER	TEST CONDITION	SYMBOL	MIN.	TYP.	MAX.	UNIT
AUX MIX ON		V _{AMH}	1.5	-	V ⁺	V
AUX MIX OFF		V _{AML}	GND	-	0.4	V

(Note) Unless specified, tested with next mode below.

TERMINAL NAME	SYMBOL	TERMINAL NUMBER	CONDITION	STATUS
		NJM2166E/V (NJM2166R)		
EVR CONTROL	EVR	9 pin (6 pin)	V _{evr} = V ⁺	EVR=MAX.
SUSPEND CONTROL	SUSPEND	6 pin (5 pin)	V _{sus} =L	SUSPEND OFF
AUX.MIX CONTROL	AM	5 pin (4 pin)	V _{am} =H	AUX.MIX ON

■ TEST CIRCUIT

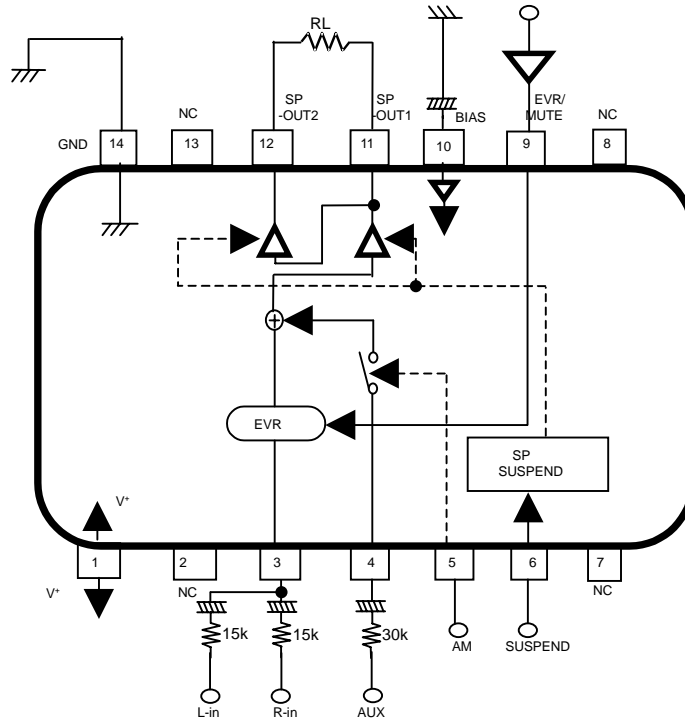

NJM2166V TEST CIRCUIT

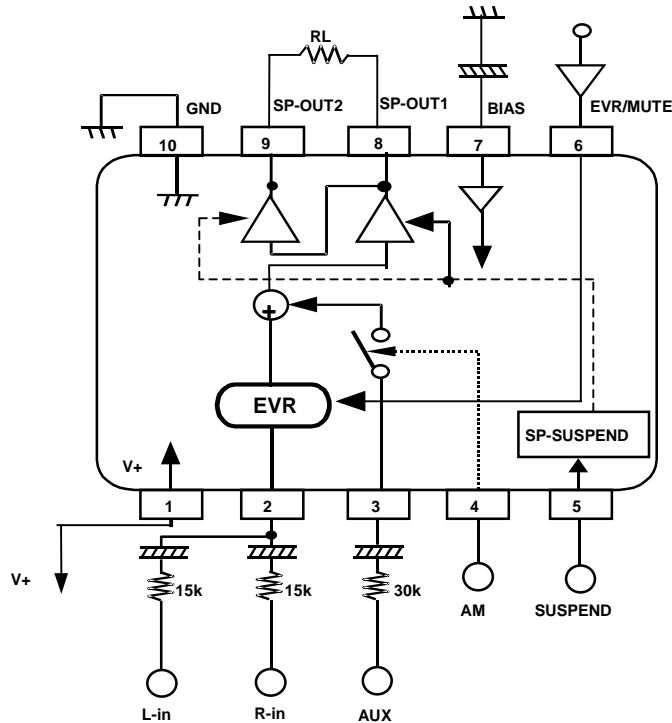

NJM2166R TEST CIRCUIT

■ TERMINAL EXPLANATION (CONDITION : $V^+ = 3.0V$)

TERMINAL NUMBER		TERMINAL NAME	FUNKTION	TERMINAL VOLTAGE(V)	OTHERS
NJM2166V	NJM2166R				
1	1	V^+	Supply Terminal	3.0	-
3	2	SP-IN	Speaker Input	1.1	Base(PNP)
4	3	AUX	AUX Input	1.1	Base(PNP)
5	4	AM	Speaker AUX.MIX ON/OFF Control	0.0	100k Ω PULL DOWN
6	5	SUSPEND	Suspend Control	-	Base(PNP)
9	6	EVR/MUTE	EVR & Mute Control	1.0	Base(PNP)-R
10	7	BIAS	Bias	1.1	Base(PNP)
11	8	SP OUT1	BTL Negative Output	1.1	EMI-F(NPN)
12	9	SP OUT2	BTL Positive Output	1.1	EMI-F(NPN)
14	10	GND	GND	0.0	-
2,7,8,13	-	NC	-	-	-

■ CONTROL TERMINAL EXPLANATION
1: MUTE CTRL (EVR)

PARAMETER	STATUS	NOTE
MUTE ON	GND-0.4V	The amplifier is not given off signal
MUTE OFF	0.4V- V^+	The amplifier is given off signal.

2: SUSPEND CTRL (SUSPEND)

PARAMETER	STATUS	NOTE
SUSPEND ON	H	Amplifier is non-active
SUSPEND OFF	L	Amplifier is active

3: AUX.MIX CTRL (AM)

PARAMETER	STATUS	NOTE
AUX MIX ON	H	AUX signal get in amplifier.
AUX MIX OFF	L	AUX signal don't get in amplifier.

■ EVR DESCRIPTION

The EVR terminal possesses that interior power amplifier gain control function. It is in proportion to input DC voltage.

And this terminal can reduction pop noise. In that case establish the voltage “mute bias level”.

This function's is shown in Figure 1.

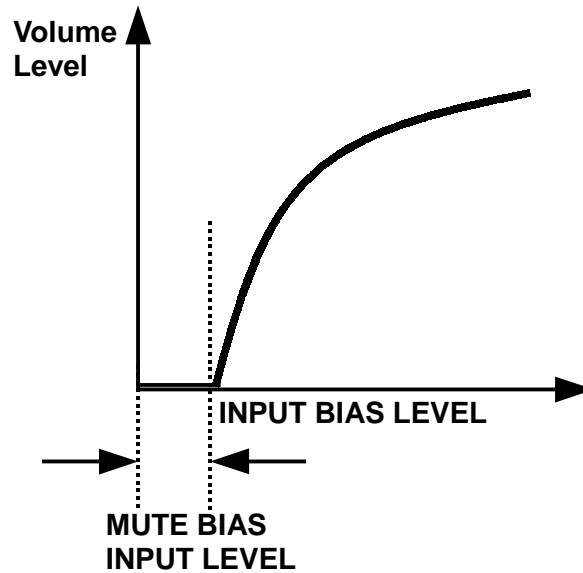

Figure 1

MEMO

[CAUTION]

The specifications on this databook are only given for information, without any guarantee as regards either mistakes or omissions. The application circuits in this databook are described only to show representative usages of the product and not intended for the guarantee or permission of any right including the industrial rights.