

MONAURAL POWER AMP. & HEADPHONE POWER AMP. IC

■ GENERAL DESCRIPTION

The **NJM2151A** is a monaural audio power amplifier and stereo headphone amplifier for wide voltage operation.

The **NJM2151A** was stereo headphone power amplifier for low distortion single-end output, and monaural power amplifier for high power bridge(BTL).

The **NJM2151A** operate low voltage supply, low operating current and low power-down current.

The **NJM2151A** includes MUTE, SUSPEND mode, and suitable for NOTE PC, PDA, CAMCODER, and other battery equipment.

The **NJM2151AVF1** is packaged in the power package.

■ PACKAGE OUTLINE

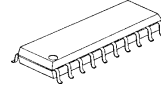

NJM2151AM

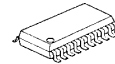

NJM2151AV

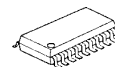

NJM2151AVF1

■ FEATURES

- Operating Voltage (2.7V to 9.0V)
- Electric Volume Function (Headphone Amplifier)
- LINE Input Mode
- System BEEP Input (Headphone)
- BEEP Level Control Function
- BEEP Input (Monaural Amplifier)
- Suspend Mode (Monaural Amplifier, Headphone Amplifier)
- Mute Mode (Headphone Amplifier)
- Bipolar Technology
- Package Outline DMP20,SSOP20,SSOP20-F1

■ PIN CONFIGURATION

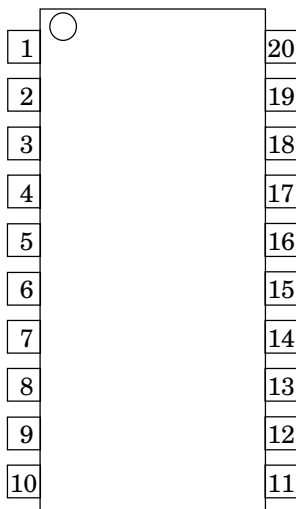

PIN CONFIGURATION

- | | |
|----------------|----------------------|
| 1. EVR | 11.SP.GND |
| 2. LINE IN L | 12.LM |
| 3. MUTE | 13.SP.OUT 2 |
| 4. LINE IN R | 14.SP.OUT 1 |
| 5. BEEP BIAS | 15.BEEP LEVEL |
| 6. SYS.BEEP IN | 16.SP.V ⁺ |
| 7. SP.IN | 17.HP.GND |
| 8. BEEP IN | 18.HP.OUT R |
| 9. HP.SUSPEND | 19.HP.OUT L |
| 10. SP.SUSPEND | 20.HP.V ⁺ |

■ ABSOLUTE MAXIMUM RATINGS (Ta=25°C)

PARAMETER	SYMBOL	RATINGS	UNIT
Supply Voltage	V ⁺	9	V
Power Dissipation	P _D	(DMP) 375 (SSOP) 375 (SSOP-F1) 750	mW
Operating Temperature Range	T _{opr}	-40 to +85	°C
Storage Temperature Range	T _{stg}	-50 to +150	°C

■ RECOMMENDED OPERATING CONDITIONS (Ta=25°C)

PARAMETER	SYMBOL	TEST CONDITION	UNIT
Operating Voltage	V _{opr}	+2.7 to +9.0	V

■ ELECTRICAL CHARACTERISTICS (HP V⁺=SP, V⁺=5V, Ta=25°C)

● Operating Current

PARAMETER	SYMBOL	TEST CONDITION	MIN.	TYP.	MAX.	UNIT
Operating Current	I _q	No Signal :I _{qHP} +I _{qSP}	-	3.0	5.0	mA
Operating Current (Suspend Mode)	I _{qs}	No Signal :I _{qHP} +I _{qSP} , V _{HS} =L, V _{SS} =L	-	252	422	μA

● HEADPHONE 1 (INPUT:LINE IN L/R, OUTPUT:HP OUT L/R)

PARAMETER	SYMBOL	TEST CONDITION	MIN.	TYP.	MAX.	UNIT
Output Voltage Level	V _{ohp1}	V _{in} =-10.0dBV	-7.4	-4.0	-1.5	dBV
Total Harmonic Distortion	THD _{hp}	V _{in} =-10.0dBV (note1)	-	0.1	1.0	%
EVR Adjustable Range	G _{evr}	V _{in} =-10.0dBV (note2), V _{evr} =HP V ⁺ →GND	70	90	-	dB
Maximum Output Level	V _{omhp}	THD=1% (note1)	-1.6	+0.6	-	dBV
Output Remain	V _{onhp}	R _g =1kΩ (note2)	-	-80	-73	dBV
Crosstalk	C _{Thp}	V _{in} =-10dBV (note2)	-	-79	-70	dBV
Muting Level	M _{Thp}	V _{in} =-10dBV:V _M =H (note2)	-	-94	-83	dBV

● HEADPHONE 2 (INPUT:SYSTEM BEEP IN, OUTPUT:HP OUT L/R)

PARAMETER	SYMBOL	TEST CONDITION	MIN.	TYP.	MAX.	UNIT
Output Voltage Level	V _{ohp2}	V _{in} =3.0Vp-p	0.22	0.32	0.42	Vp-p
Input Threshold Level	V _{THHP}		4.50	-	5.00	Vp-p

● SPEAKER AMP1 (INPUT:SP IN,OUTPUT:SP OUT1/2)

PARAMETER	SYMBOL	TEST CONDITION	MIN.	TYP.	MAX.	UNIT
Output Voltage Level	Vosp	Vin=-10.0dBV	-1.4	+2.0	+4.5	dBV
Total Harmonic Distortion	THDsp	Vin=-10.0dBV (note1)	-	0.7	2.0	%
Maximum Output Level	V _{OMsp}	THD=3% (note1)	+3.5	+5.7	-	dBV
Output Remain Noise	Vonsp	Rg=1kΩ (note2)	-	-82	-78	dBV
Line Mix Off Level	Vooffsp	Vin=-12dBV, V _L =H (note2)	-	-78	-70	dBV

● SPEAKER AMP2 (INPUT:PM BEEP IN,OUTPUT:SP OUT 1/2)

PARAMETER	SYMBOL	TEST CONDITION	MIN.	TYP.	MAX.	UNIT
Output Level	Vosp2	Vin=-10.0dBV	-7.4	-4.0	-1.5	dBV

(note1):B.W.=0.4 to 30kHz ,(note2):CCIR

● CONTROL BLOCK
MUTE CONTROL (3pin:MUTE-CTRL)

PARAMETER	SYMBOL	TEST CONDITION	MIN.	TYP.	MAX.	UNIT
HP Mute Off	V _{ML}		GND	-	0.4	V
HP Mute On	V _{MH}		1.5	-	V ⁺	V

HEADPHONE SUSPEND CONTROL (9pin:HPSUS-CTRL)

PARAMETER	SYMBOL	TEST CONDITION	MIN.	TYP.	MAX.	UNIT
HP Suspend On	V _{HPSL}		GND	-	0.4	V
HP Suspend Off	V _{HPSH}		1.5	-	V ⁺	V

SPEAKER SUSPEND Control (10pin:SPSUS-CTRL)

PARAMETER	SYMBOL	TEST CONDITION	MIN.	TYP.	MAX.	UNIT
SP Suspend On	V _{SPSL}		GND	-	0.4	V
SP Suspend Off	V _{SPSH}		1.5	-	V ⁺	V

LINE MIX ON/OFF Control (12pin:LINE MIX ON/OFF CTRL)

PARAMETER	SYMBOL	TEST CONDITION	MIN.	TYP.	MAX.	UNIT
Line Mix On	V _{LL}		GND	-	0.4	V
Line Mix Off	V _{LH}		1.5	-	V ⁺	V

(Note) Unless specified, tested with next mode below.

FUNCTION	SYMBOL	PIN.No	CONDITION	STATUS
EVR Control	V _{evr}	1pin	V _{evr} =V ⁺	EVR=Max
Mute Control	V _M	3pin	V _M =L	Mute Off
Headphone Suspend Control	V _{HPS}	9pin	V _{HPS} =H	Suspend Off
Speaker Suspend Control	V _{SPS}	10pin	V _{SPS} =H	Suspend Off
Line Mix Control	V _L	12pin	V _L =L	Line Mix On

■ BLOCK DIAGRAM

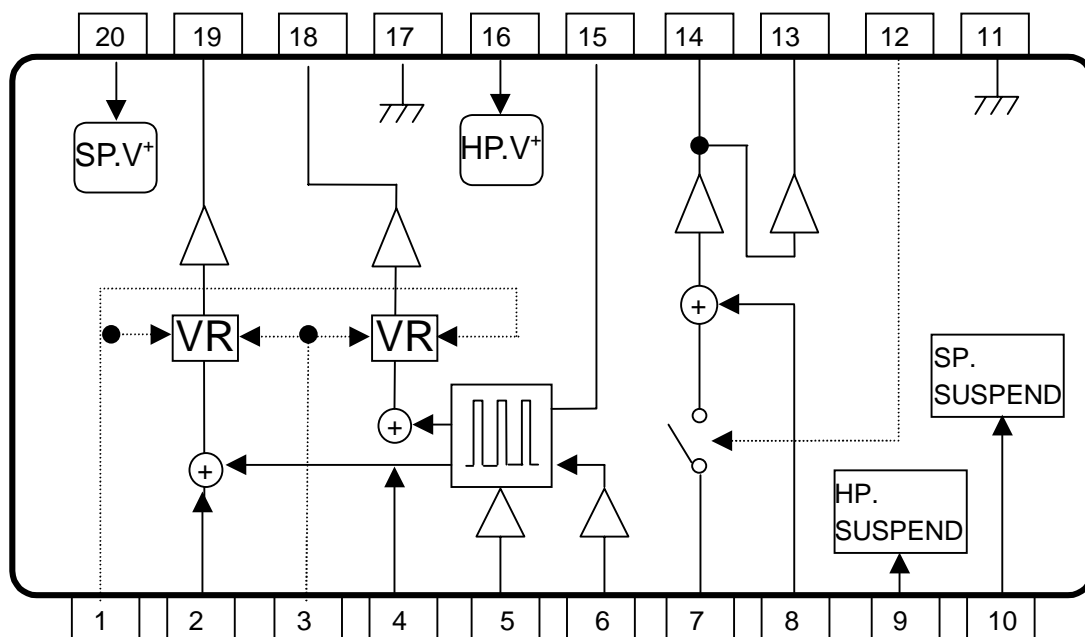

■ PIN FUNCTION (SP V⁺=3.0V,HP V⁺=3.0V)

PIN No.	SYMBOL	FUNCTION	PIN VOLTAGE(V)	EQUIVALENT CIRCUIT
1	EVR	EVR Control	-	Base(PNP)
2	LINE-IN-L	Line Lch Input	1.5	Base(PNP)
3	MUTE	Headphone Mute Control	3.0	100kΩ Pull Down Base(PNP)
4	LINE-IN-R	Line Rch Input	2.5	Base(PNP)
5	BEEP BIAS	Bias	1.5	64kΩ
6	SYS.BEEP-IN	System BEEP Input	1.5	Base(PNP)
7	SP.IN	Speaker Amp. Input	1.5	Base(PNP)
8	BEEP IN	Speaker BEEP Input	1.5	Base(PNP)
9	HP.SUSPEND	Headphone Suspend	-	Base(PNP)
10	SP.SUSPEND	Speaker Suspend Control	-	Base(PNP)
11	SP.GND	GND for Speaker	0.0	-
12	LM	Speaker Line Mix On/Off Control	3.0	100k Ω Pull Up Base(PNP)
13	SP.OUT2	BTL Invert Output	1.5	Emitter Follower (NPN)
14	SP.OUT1	BTL Non-Invert Output	1.5	Emitter Follower (NPN)
15	BEEP LEVEL	System BEEP Output Level Control	2.3	C(PNP)-3kΩ
16	SP.V ⁺	Supply for Speaker	3.0	-
17	HP.GND	GND for Headphone	0.0	-
18	HP.OUT R	Headphone Rch Output	1.5	Emitter Follower (NPN)
19	HP.OUT L	Headphone Lch Output	1.5	Emitter Follower (NPN)
20	HP.V ⁺	Supply for Headphone	3.0	-

■ TEST CIRCUIT

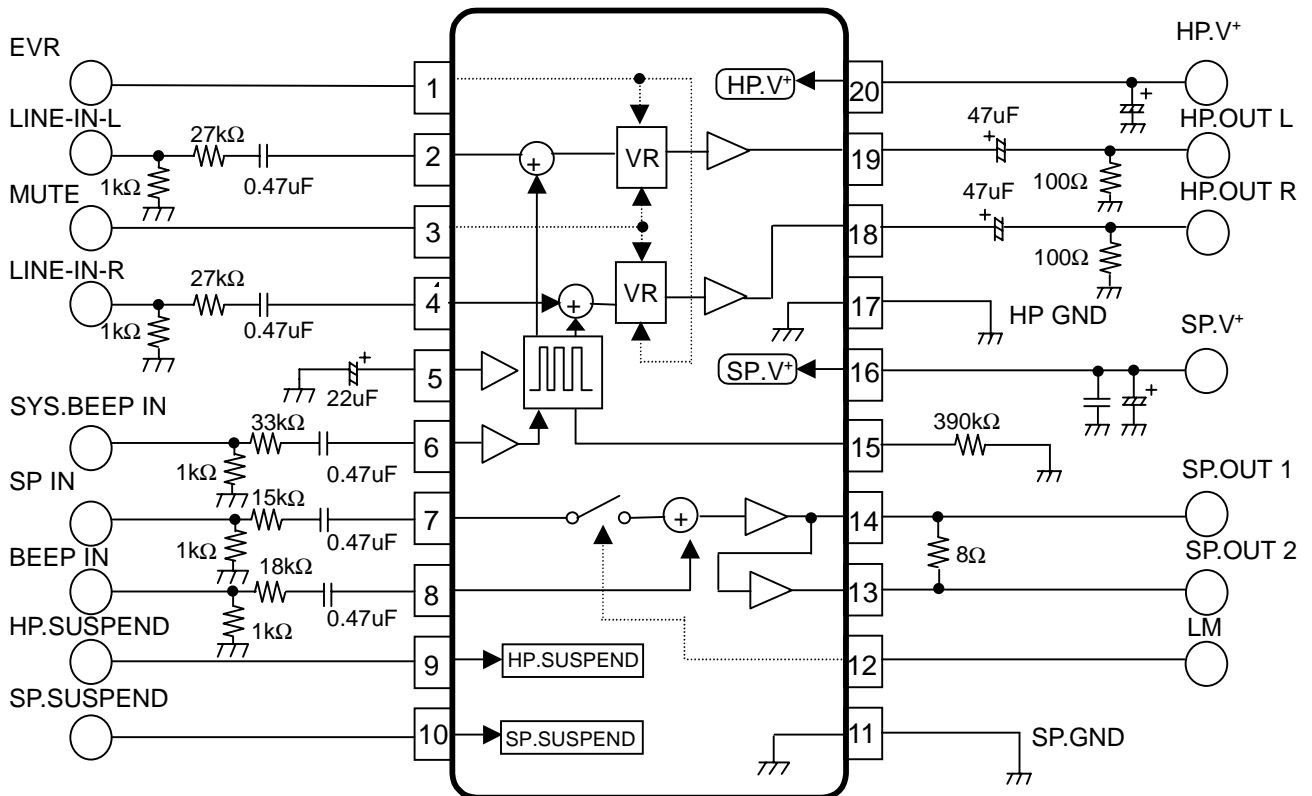

■ CONTROL TERMINAL EXPLANATION

1:MUTE CTRL (3pin)

PARAMETER	STATUS	NOTE
HP. Mute On	H	HP.AMP. is not given off signal.
HP. Mute Off	L	HP.AMP. is given off signal.

2:HP.SUSPEND CTRL (9pin)

PARAMETER	STATUS	NOTE
HP. Suspend Off	H	HP.AMP. is active.
HP. Suspend On	L	HP.AMP. is non-active.

3:SP.SUSPEND CTRL (10pin)

PARAMETER	STATUS	NOTE
SP. Suspend Off	H	SP.AMP. is active.
SP. Suspend On	L	SP.AMP. is non-active.

4:LINE MIX ON/OFF CTRL (12pin)

PARAMETER	STATUS	NOTE
Line Mix Off	H	Signal don't get in SP.AMP.
Line Mix On	L	Signal get in SP.AMP.

APPLICATION CIRCUIT

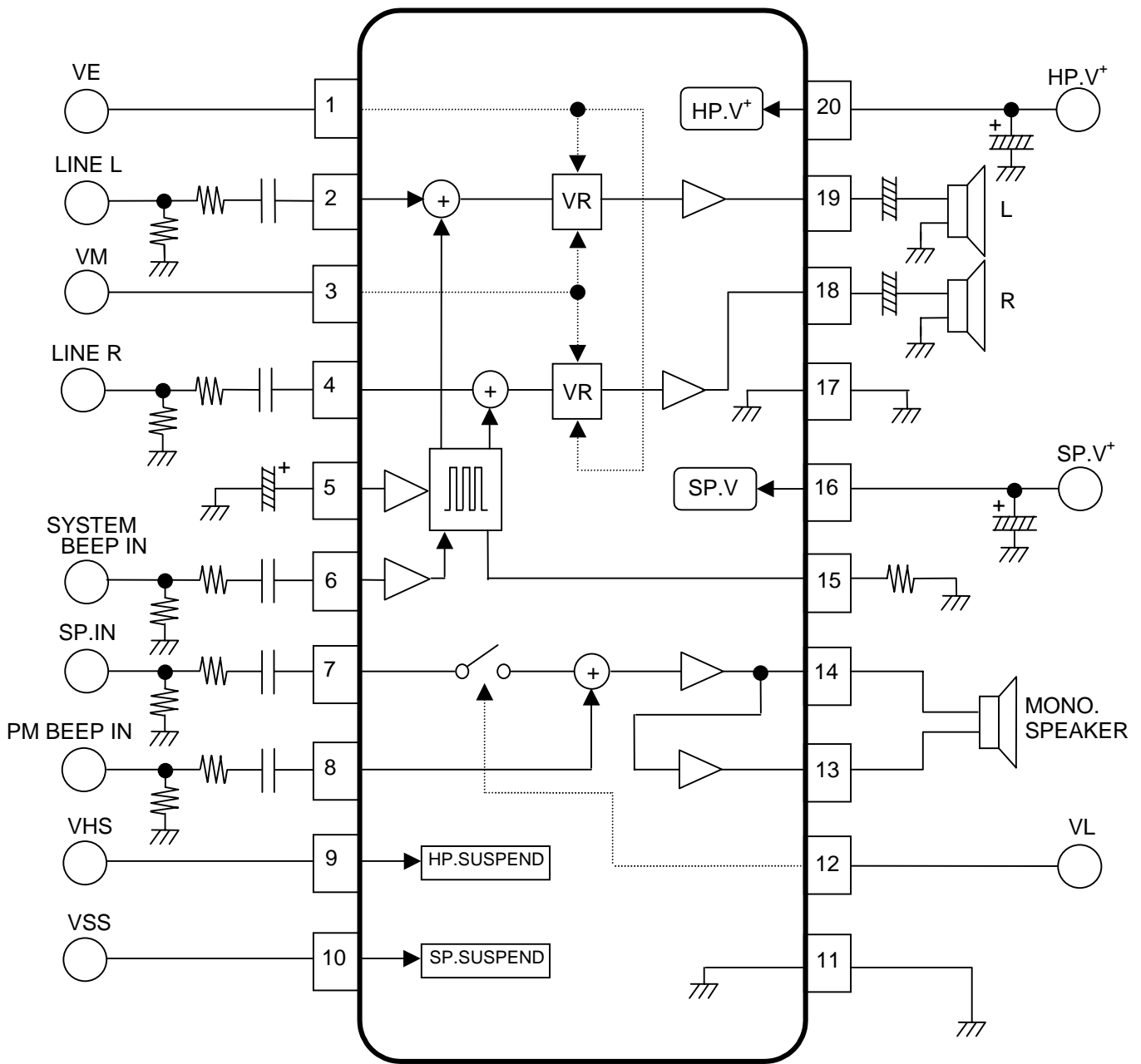

■ EQUIVARENT CIRCUIT

PIN No.	FUNCTION	EQUIVARENT CIRCUIT	PIN No.	FUNCTION	EQUIVARENT CIRCUIT
1	EVR		6	SYS.BEEP IN	
2	LINE-IN-L		7	SP.IN	
3	MUTE		8	BEEP-IN	
4	LINE-IN-R		9	HP.SUSPE ND	
5	BEEP BIAS		10	SP.SUSPE ND	

■ EQUIVARENT CIRCUIT

PIN No.	FUNCTION	EQUIVARENT CIRCUIT	PIN No.	FUNCTION	EQUIVARENT CIRCUIT
11	SP.GND	—————	16	SP.V ⁺	—————
12	LM		17	HP.GND	—————
13	SP.OUT 2		18	HP.OUT R	
14	SP.OUT 1		19	HP.OUT L	
15	BEEP LEVEL		20	HP.V ⁺	—————

MEMO

[CAUTION]

The specifications on this databook are only given for information, without any guarantee as regards either mistakes or omissions. The application circuits in this databook are described only to show representative usages of the product and not intended for the guarantee or permission of any right including the industrial rights.