

## Full Color LED Controller Driver with PWM Control

### ■ GENERAL DESCRIPTION

The **NJU6062** is a full color LED controller driver. It can control and drive a 3 in 1 packaged (Red, Green and Blue) LED.

The **NJU6062** contains PWM luminance (Pulse Width Modulation) control circuit, LED driving circuit, MPU interface.

The PWM signal control the duty cycle of each RGB LED delicately, therefore can recognize a lot of colors.

Enable terminal (ON/OFF) is possible to synchronize with a sound source..

It requires only four external components such as three resistors for LED current adjustment, which enables the **NJU6062** to save PCB space.

Multi Device control is enabled and it is possible to control the multiple **NJU6062** by a I<sup>2</sup>C address.

The **NJU6062** is suitable for cellular phone, car audio and so on.

### ■ PACKAGE OUTLINE

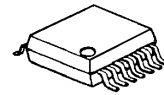

**NJU6062V  
(SSOP14)**

### ■ FEATURES

- Controlling a 3-in-1 packaged RGB LED
- 4-channel output  $I_{LED}=30mA \times 4$
- Built-in PWM luminance control (256steps x 4)
- Built-in I<sup>2</sup>C interface circuit
- Multi Device control
- Built-in CR oscillation circuit
- Operating voltage 1.8V to 5.5V
- Package SSOP14
- CMOS Technology

## ■ PIN CONNECTIONS (TOP VIEW)

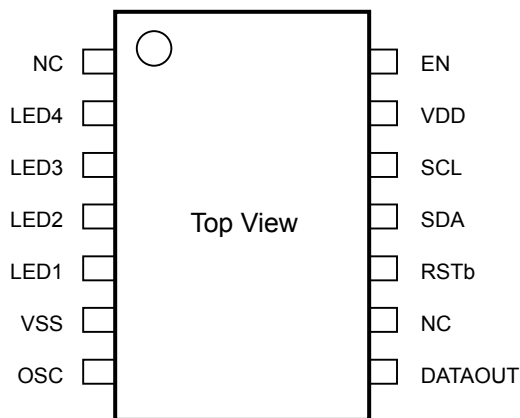

SSOP14

## ■ PIN DESCRIPTIONS

PIN No.	PIN NAME	TYPE	DESCRIPTIONS
12	SCL	Input	Serial Clock terminal
11	SDA	Input / Output	Serial Data terminal
10	RSTb	Input	Reset terminal - Active "L". "L" status: Reset state "H" status: Operating state
8	DATAOUT	Output	Multi Device control terminal (connect RSTb of next NJU6062 for Multi Device use.)
7	OSC	Input	External clock input terminal It is used by external clock. Normally open.
6	V <sub>SS</sub>	Power	Ground terminal
5	LED1	Output	LED Connect terminals (Open drain output) Output level can be divided into 256 steps by PWM signal. Connecting with the cathode of LED.
4	LED2	Output	
3	LED3	Output	
2	LED4	Output	
14	EN	Input	Enable terminal built-in Pull-up resistor "H" : LED ON "L" : LED OFF
13	V <sub>DD</sub>	Power	V <sub>DD</sub> Power Supply terminal
1,9	NC		Non Connect These terminals are electrically open.

## BLOCK DIAGRAM

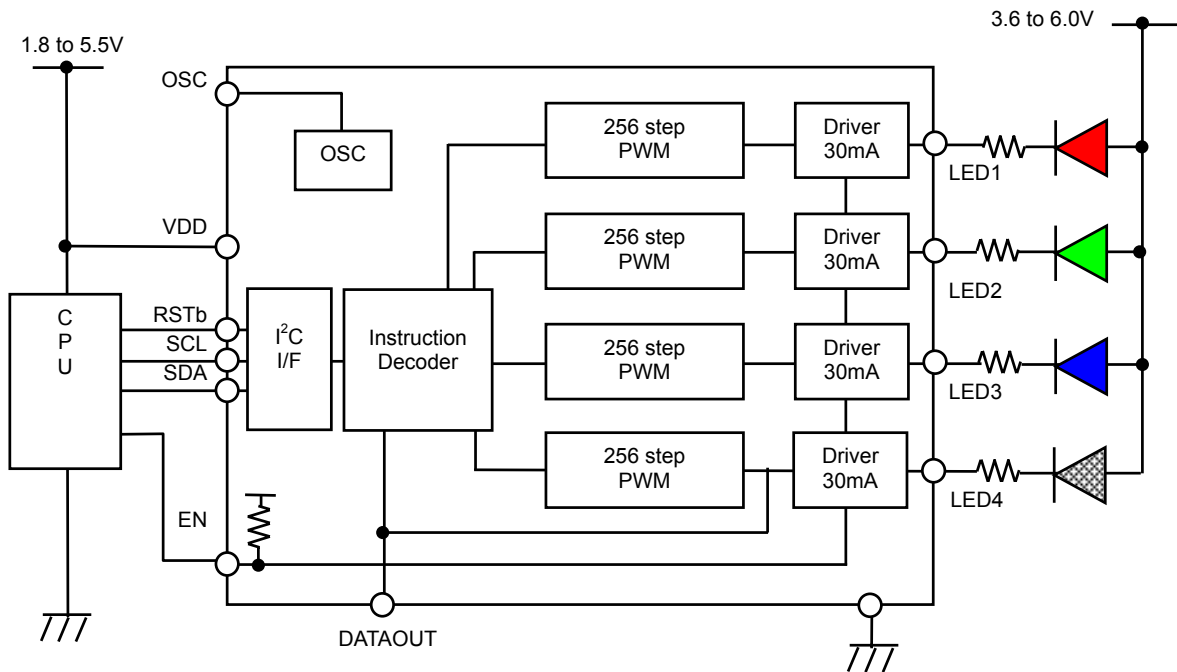

## FUNCTIONAL DESCRIPTIONS

### (1) Description for Each Blocks

#### (1-1) PWM Luminance Control

The **NJU6062** incorporates four 256 steps PWM Luminance Control circuits. At the user's option, PWM data can be set. PWM data set by selecting start point(S) and end point(E) of each terminal.

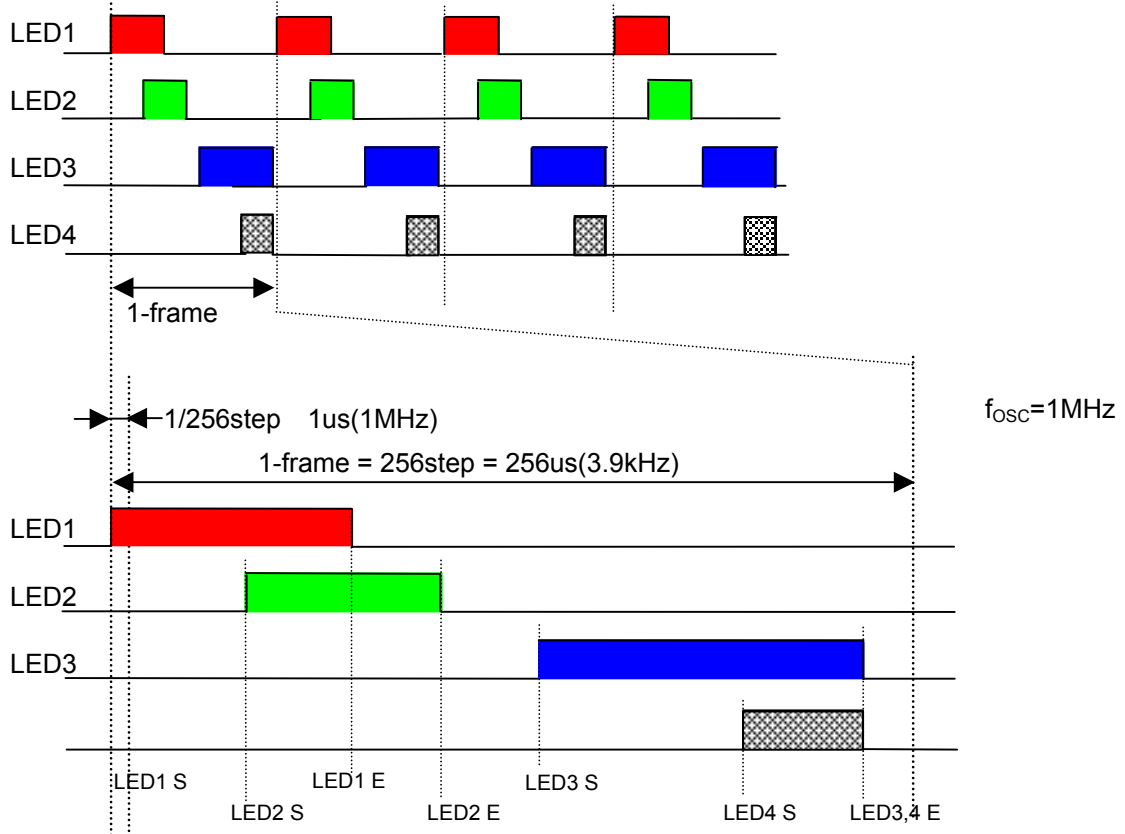

## (1-2) Oscillator

The oscillation circuit with the internal register and capacitor generates the clock signal for PWM.

The oscillation circuit can be turned on/off by the instruction to minimize the current consumption.

The oscillation frequency (fosc) can be selected in 16 conditions by the instruction.

Additionally, it can operate the external clock without using the internal oscillation circuit.

If not zero PWM signal is still output after the oscillation circuit OFF, write "00h" into the start point(S) and end point(E) register or let EN = "L".

## (1-3) Enable function

The enable terminal (EN terminal) is used to turn on/off the device from the external. The register value does not change by this signal. When EN terminal is not used open.

(2) Instructions

The data transfer between CPU and the **NJU6062** is via a I<sup>2</sup>C interface.

Table.1 shows the instruction codes of the **NJU6062**.

Table 1. Instruction Code

\* : Don't Care

Instruction		Lower address	Code								Description
			D <sub>7</sub>	D <sub>6</sub>	D <sub>5</sub>	D <sub>4</sub>	D <sub>3</sub>	D <sub>2</sub>	D <sub>1</sub>	D <sub>0</sub>	
(a)	Function Set	00h	AI	PWM	FC <sub>1</sub>	FC <sub>0</sub>	FD <sub>1</sub>	FD <sub>0</sub>	EXT	FS	AL : Address increment PWM : PWM output FC <sub>1</sub> , FC <sub>0</sub> : OSC freq. Select FD <sub>1</sub> , FD <sub>0</sub> : Divide ratio Select EXT : External OSC use FS : Internal OSC ON/OFF
(b)	LED1 Start	01h	PWM data/ Start Point								PWM data/ Start Point / End Point Set
	LED2 Start	02h									
	LED3 Start	03h									
	LED4 Start	04h									
	LED1End	05h	PWM data/ End Point								
	LED 2End	06h									
	LED3 End	07h									
	LED4 End	08h									
(c)	Update/ Static on	09h	UD <sub>4</sub>	UD <sub>3</sub>	UD <sub>2</sub>	UD <sub>1</sub>	GP <sub>4</sub>	GP <sub>3</sub>	GP <sub>2</sub>	GP <sub>1</sub>	UD <sub>1</sub> to UD <sub>4</sub> : Data update GP <sub>1</sub> ~GP <sub>4</sub> : Statifc ON/OFF
	NOP	0Ah~0Fh	*	*	*	*	*	*	*	*	Non Operation code (Not Applicable)
(d)	Multi Device Address set	10h	MA <sub>7</sub>	MA <sub>6</sub>	MA <sub>5</sub>	MA <sub>4</sub>	MA <sub>3</sub>	MA <sub>2</sub>	MA <sub>1</sub>	MA <sub>0</sub>	Multi Device mode address set
	NOP	11h~1Eh	*	*	*	*	*	*	*	*	Non Operation code (Not Applicable)
(e)	Maker Testing	1Fh	T <sub>7</sub>	T <sub>6</sub>	T <sub>5</sub>	T <sub>4</sub>	T <sub>3</sub>	T <sub>2</sub>	T <sub>1</sub>	T <sub>0</sub>	Inhibited command
	Inhibited command	20h~FFh	*	*	*	*	*	*	*	*	Inhibited command

## (2-1) Explanation of Instruction Code

Lower address: 00h ~ 09h. It is incremented within the loop 05h ~ 09h.

Therefore, until the stop condition is reached, it is possible to write instructions that from the LED1 endpoint to the update continuously

INSTRUCTION	DATA	REMARKS
START CONDITION		I <sup>2</sup> C Start Condition
SLAVE ADDRESS	40h	The Device Slave Address
UPPER ADDRESS	00h	Multi Device Address
LOWER ADDRESS	00h	The Internal Register Address
INITIAL SETTING	01h	Initial Setting of Oscillation Frequency and so on
LED1 START	00h	The Start Point Setting
LED2 START	00h	
LED3 START	00h	
LED4 START	00h	
LED1 END	10h	
LED2 END	10h	
LED3 END	10h	
LED4 END	10h	
UPDATE	F0h	Update of Start/End Point
LED1 END	20h	The End Point Re-setting
LED2 END	20h	
LED3 END	20h	
LED4 END	20h	
UPDATE	F0h	
STOP CONDITION		I <sup>2</sup> C Stop Condition
START CONDITION		I <sup>2</sup> C Start Condition
SLAVE ADDRESS	40h	The Device Slave Address
UPPER ADDRESS	00h	Multi Device Address
LOWER ADDRESS	05h	The Internal Register Address
LED1 END	30h	The End Point Re-setting
LED2 END	30h	
LED3 END	30h	
LED4 END	30h	
UPDATE	F0h	
STOP CONDITION		I <sup>2</sup> C Stop Condition

(2-2) Instruction Code

(a) Function Set

This instruction set the Address increment, Oscillation set PWM output select Function.

Lower address	D <sub>7</sub>	D <sub>6</sub>	D <sub>5</sub>	D <sub>4</sub>	D <sub>3</sub>	D <sub>2</sub>	D <sub>1</sub>	D <sub>0</sub>
00h	AI	PWM	FC <sub>1</sub>	FC <sub>0</sub>	FD <sub>1</sub>	FD <sub>0</sub>	EXT	FS

Lower address increment set

Set the increment of the address of the write data.

It is possible to write the PWM data without address setting.

- D<sub>7</sub> 0 : End point loop (return from 09h to 05h) (Default)
- 1 : All loop (return from 09h to 00h)

Lower address : When AI at "L", it returns from 09h to 05h. Then it enters the loop.

Ex.) 00h→01h→02h . . . 09h→05h . . . 09h→05h . . .

Lower address : When AI at "H", it returns from 09h to 00h. Then it enters the loop.

Ex.) 00h→01h→02h . . . 09h→00h . . . 09h→00h . . .

LED4 PWM Output ON/OFF set

DATAOUT terminal outputs the PWM waveform(LED4).

It is possible to control the external circuit requiring PWM control.

It is the ban on use under the Multi Device control.

- D<sub>6</sub> 0 : LED4 terminal output(Default)
- 1 : DATAOUT terminal Output (LED4 terminal output"L")

OSC frequency select

It is possible to switch the OSC frequency of the internal oscillation circuit between the 4-type OSC frequency.

FC <sub>1</sub>	FC <sub>0</sub>	OSC frequency(f <sub>osc</sub> )
0	0	1MHz
0	1	1.2MHz
1	0	2.2MHz
1	1	800kHz

Divide ratio select

Set the Frame Frequency. Select 16-type frame frequency by combining Divide ratio with OSC frequency.

External clock input mode select for 4-type frame frequency.

FD <sub>1</sub>	FD <sub>0</sub>	frame frequency	Ex.) frame frequency			
			f <sub>osc</sub> =1MHz	f <sub>osc</sub> =1.2MHz	f <sub>osc</sub> =2.2MHz	f <sub>osc</sub> =800kHz
0	0	f <sub>osc</sub> / 256	3.9KHz	4.69KHz	8.59KHz	3.1KHz
0	1	f <sub>osc</sub> / 512	1.95KHz	2.34KHz	4.30KHz	1.56KHz
1	0	f <sub>osc</sub> / 1024	975Hz	1.17KHz	2.15KHz	781Hz
1	1	f <sub>osc</sub> / 2048	488Hz	586Hz	1.07KHz	391Hz

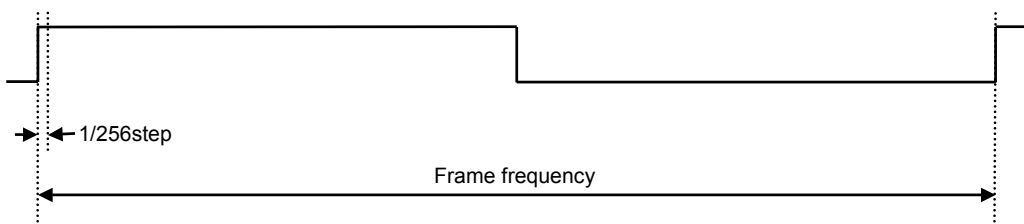

EXT : External clock input mode set

The NJU6062 can be operated with external clock input without using internal oscillation circuit. In the case of using external clock, set D<sub>1</sub> = "H", and enter it from the OSC terminal.

- D<sub>1</sub> 0 : Internal Oscillator use(Default)
- 1 : External clock input from OSC terminal

FS : OSC ON/OFF set

Set the internal oscillation or external clock ON/OFF

- D<sub>0</sub> 0 : Oscillator OFF(Default)
- 1 : Oscillator ON

### (b) PWM data Set

This instruction set start point(S) and end point(E) of each terminal.

Set the start point(S) and end point(E) of the PWM data corresponding to the each LED terminal. Accordingly, PWM data is changed by the internal counter.

It is possible to set the PWM output to the steps 0~255.

256/256 can be set by static on.

### PWM data set example

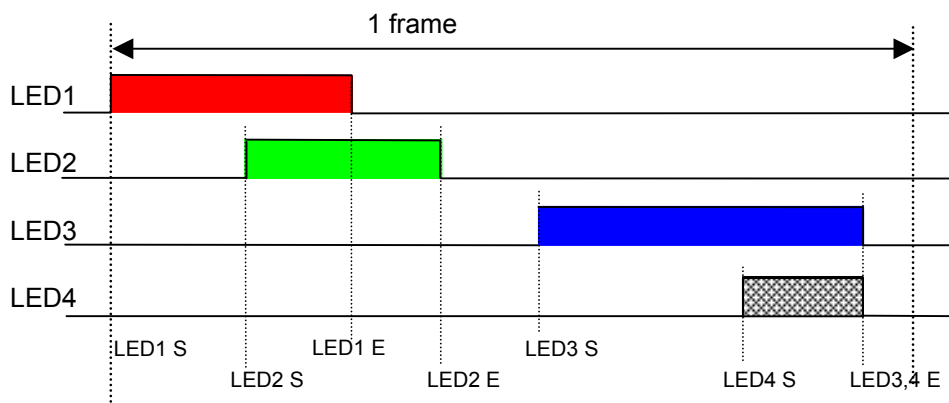

The relationship between PWM duty cycle and the register value is shown as below:

PWM <sub>7</sub>	PWM <sub>6</sub>	PWM <sub>5</sub>	PWM <sub>4</sub>	PWM <sub>3</sub>	PWM <sub>2</sub>	PWM <sub>1</sub>	PWM <sub>0</sub>	Start Point End Point
0	0	0	0	0	0	0	0	0/256
0	0	0	0	0	0	0	1	1/256
0	0	0	0	0	0	1	0	2/256
0	0	0	0	0	0	1	1	3/256
0	0	0	0	0	1	0	0	4/256
0	0	0	0	0	1	0	1	5/256
⋮								
1	1	1	1	1	1	0	1	253/256
1	1	1	1	1	1	1	0	254/256
1	1	1	1	1	1	1	1	255/256

Calculating formula is as follows.

$$DUTY = E - S \quad \dots (1)$$

If the result of (1) is negative, the calculating formula is as below.

$$DUTY = E - S + 256 \quad \dots (2)$$

**(c) Update / Static on**

This instruction is active PWM data to LED terminal output / LED terminal is made "H" regardless of PWM data.

Lower address	D <sub>7</sub>	D <sub>6</sub>	D <sub>5</sub>	D <sub>4</sub>	D <sub>3</sub>	D <sub>2</sub>	D <sub>1</sub>	D <sub>0</sub>
09h	UD <sub>4</sub>	UD <sub>3</sub>	UD <sub>2</sub>	UD <sub>1</sub>	GP <sub>4</sub>	GP <sub>3</sub>	GP <sub>2</sub>	GP <sub>1</sub>

**UD<sub>4</sub> ~ UD<sub>1</sub> : Update**

Set the update of PWM data of each LED terminal.

Setting UD<sub>4</sub>~UD<sub>1</sub> bit corresponding to each LED terminal to "H", PWM output is updated to PWM data that is set at section (b).

In the case of setting it to "L", it is not updated.

UD<sub>4</sub>=LED4, UD<sub>3</sub>=LED3, UD<sub>2</sub>=LED2, UD<sub>1</sub>=LED1

The update of PWM data is synchronized with the frame, and it is valid in the next frame.

**GP<sub>4</sub> ~ GP<sub>1</sub> : Static on**

When GP<sub>4</sub>~GP<sub>1</sub> bit corresponding to each LED terminal is set to "H", the PWM data is disabled and the output is enabled.

Process of turn off of each LED terminal : Set GP<sub>4</sub>~GP<sub>1</sub> bit to "L" to enable the PWM data, and set startpoint (S) and endpoint (E) of the PWM dataset to 00h.

Additionally, all terminal is set to "L" by setting EN terminal to "L"

GP<sub>4</sub>=LED4, GP<sub>3</sub>=LED3, GP<sub>2</sub>=LED2, GP<sub>1</sub>=LED1

Static on: It is not synchronized with the frame and is also valid in the case of the update "L"

And it is ban on use under the Multi Device control.

**(d) Multi Device address set**

Set the Multi Device address when the Multi Device is connected.

Multi Device address (MA) : 01h~Feh

It has 254 patterns of address.

Lower address	D <sub>7</sub>	D <sub>6</sub>	D <sub>5</sub>	D <sub>4</sub>	D <sub>3</sub>	D <sub>2</sub>	D <sub>1</sub>	D <sub>0</sub>
10h	MA <sub>7</sub>	MA <sub>6</sub>	MA <sub>5</sub>	MA <sub>4</sub>	MA <sub>3</sub>	MA <sub>2</sub>	MA <sub>1</sub>	MA <sub>0</sub>

MA <sub>7</sub>	MA <sub>6</sub>	MA <sub>5</sub>	MA <sub>4</sub>	MA <sub>3</sub>	MA <sub>2</sub>	MA <sub>1</sub>	MA <sub>0</sub>	Upper address
0	0	0	0	0	0	0	1	01h
0	0	0	0	0	0	1	0	02h
0	0	0	0	0	0	1	1	03h
0	0	0	0	0	1	0	0	04h
0	0	0	0	0	1	0	1	05h



1	1	1	1	1	1	0	1	FDh
1	1	1	1	1	1	1	0	FEh
1	1	1	1	1	1	1	1	FFh

## (3) Data Input Timing

Data format is shown below.

There are upper address and lower address with slave address. When multi Device control is used, upper address is used for the device select. Lower address identifies each instruction.

Please set 00h when you do not use the multi Device control(For 1 piece use).

The data of SDA is taken by rising edge about SCL.

Lower address does the increment based on Lower address increment set(AI) instruction.

It is possible to write it continuously until the stop condition is approved.

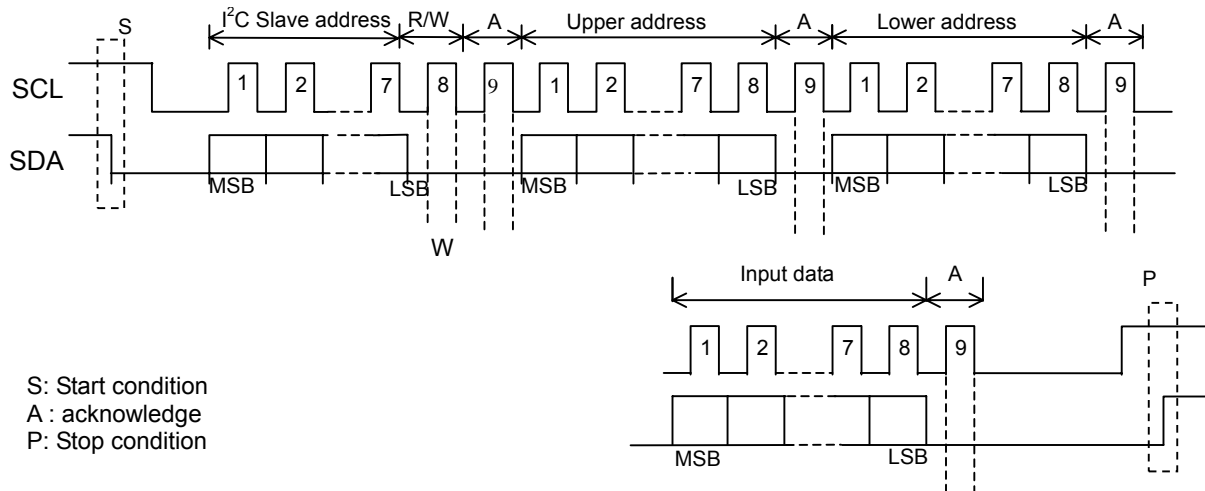

### 1. Start condition

A fall edge of the SDA terminal while the SCL terminals "H", which situation defines the Start conditions.

### 2. Slave address

First bite defines the slave address of NJU6062. Slave address is (40)h. When NJU6062 acknowledges coincidence its own address with the address in the first byte, it outputs the acknowledge just after the first byte(at ninth bit timing) through the SDA terminal.

### 3. R/W condition

NJU6062 is only for slave LSI, and the data D0 in the first byte(at eighth bit timing) should be "0".

### 4. Upper address

Second bite defines the Upper address, it outputs the acknowledge just after the ninth bit timing through the SDA terminal.

### 5. Lower address

Third bite defines the Lower address, it outputs the acknowledge just after the ninth bit timing through the SDA terminal.

### 6. Data

After fourth bite, transfer the display data bite.

### 7. Stop condition

A rise edge of the SDA terminal while the SCL terminal is "H", which situation defines the STOP condition.

### 8. Repeat start condition

After start condition set, a fall edge of the SDA terminal while the SCL terminals "H", which situation next data read start.

## (4) Reset Circuit

The device is initialized by inputting a more than 400ns long signal into the RES terminal. Instruction can be input after 1us away from the rising edge of the reset signal,

Reset status using the RES terminal

- 1, Address increment 0: End point loop (return from 09h to 05h)
- 2, PWM Output ON/OFF 0: LED4 terminal output
- 3, OSC frequency select 0,0: 1MHz
- 4, Divide ratio select 0,0: fosc/256
- 5, Internal Oscillator use
- 6, Oscillator OFF
- 7, PWM data (Start / End point) 00h
- 8, Update / Static on 00h
- 9, Multi Device address 00h
- 10, I<sup>2</sup>C interface reset

## (5) Multi Device control

It is possible to control multiple NJU6062 by a I<sup>2</sup>C address.

Connect the DATAOUT and RSTb terminal, and Multi Device control is enabled by assigning a unique address to each device in default configuration.

Upper address (MA) is a unique address under the Multi Device control.

It has 254 sets of address (01h~Feh).

After reset, upper address is set to "00h".

Output "L" from DATAOUT terminal when the upper address is "00h".

Output "H" from DATAOUT terminal when the upper address is "01h~FFh".

Writing of data : Write the data to the device of the upper address assigned in default configuration

Selecting FFh to the upper address, all connected devices are dynamically updated.

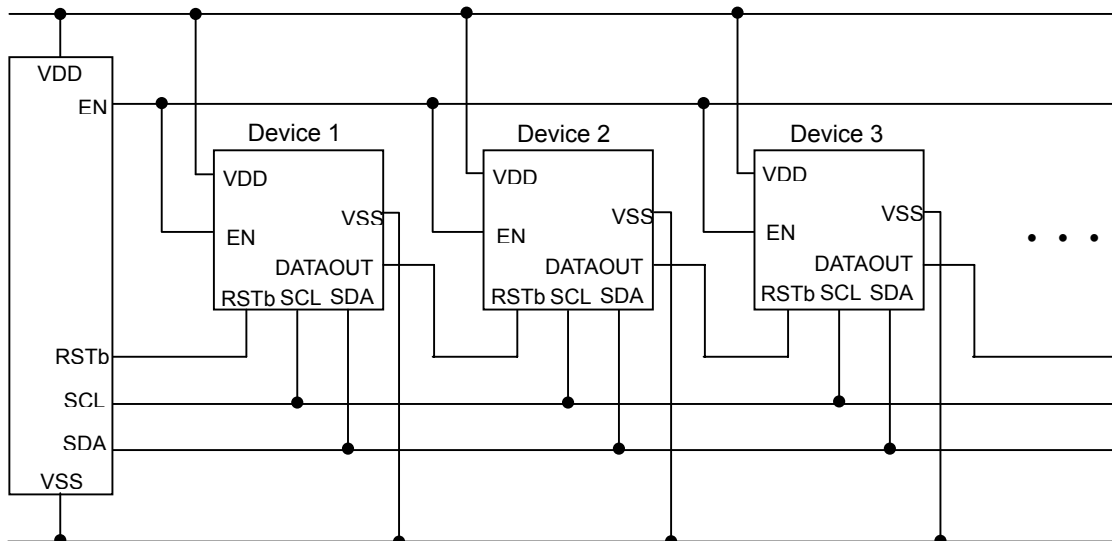

(5-1) Multi Device control Initialization from (Multi Device address set)

Ex.) NJU6062 x 3 devices

SLAVE ADDRESS +R/W	REGISTER UPPER ADDRESS	REGISTER LOWER ADDRESS	INPUT DATA			
40h	00h	10h	01h	-	-	Set the upper address of device1 to 01h. RSTb="L" Therefore, device2 and 3 are not responding.
40h	00h	10h	02h	-	-	Set the upper address of device2 to 02h. Device 1 has been set to "01h". RSTb="L" Therefore, device3 is not responding
40h	00h	10h	03h	-	-	Set the upper address of device3 to 03h. Device1 has been set to "01h". Device2 has been set to "02h".
40h	FFh	00h	01h	-	-	Send commands (default) to all devices.
40h	01h	01h	00h	09h	••••	Set the start point and end point to device1. Then update it.
40h	02h	01h	00h	09h	••••	Set the start point and end point to device2. Then update it.
40h	03h	01h	00h	09h	••••	Set the start point and end point to device3. Then update it.

- After reset upper address Initial value : 00h

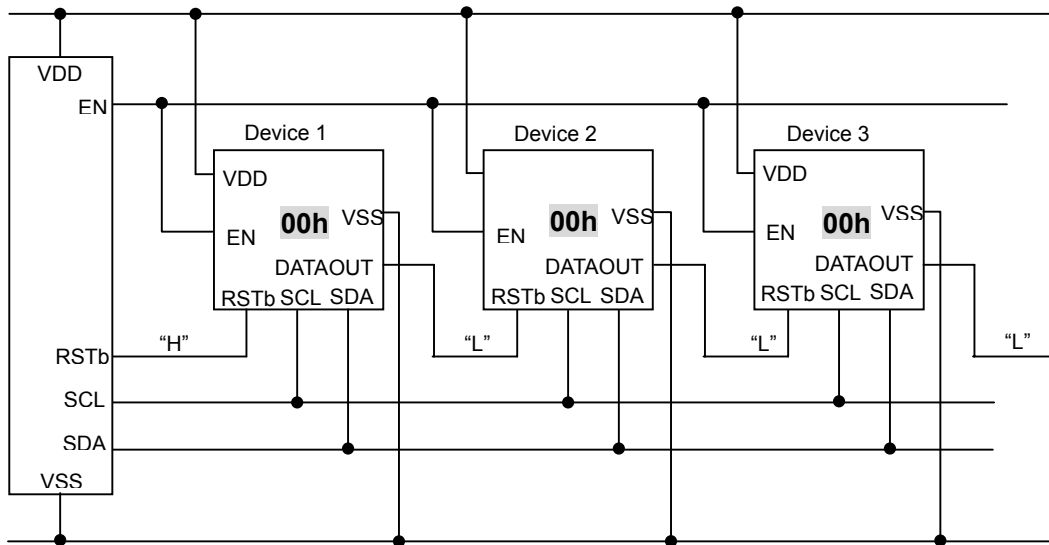

- After address set Initialization

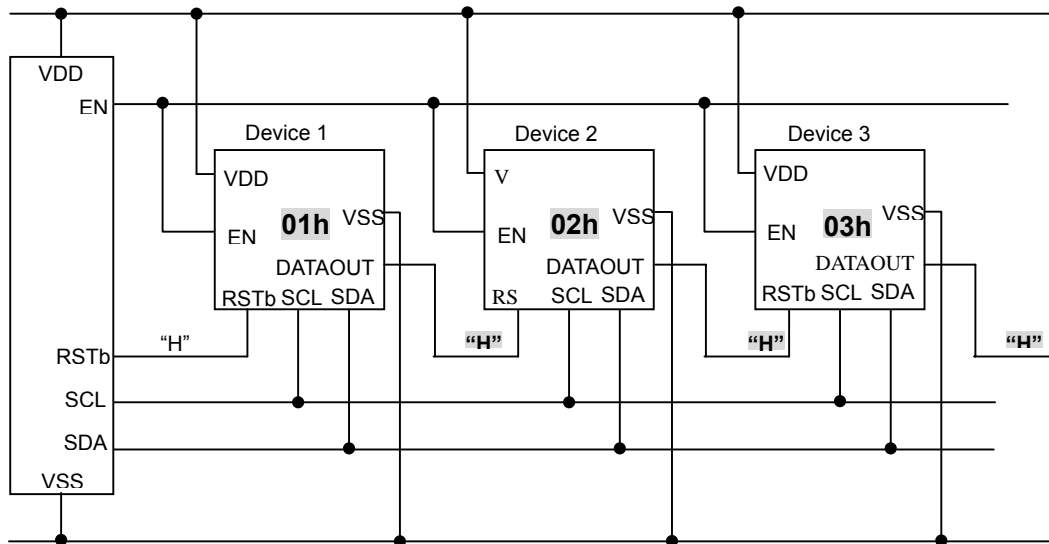

## ■ ABSOLUTE MAXIMUM RATINGS

Ta=25°C

PARAMETERS	SYMBOL	CONDITIONS	RATINGS	UNIT
VDD Power Supply	V <sub>DD</sub>	VDD terminal	-0.3 to +7.0	V
Driver Off Break Down Voltage	V <sub>offmax</sub>	LED1, LED2, LED3,LED4 terminals	7.0	V
Driver On Break Down Voltage	V <sub>onmax</sub>	LED1, LED2, LED3,LED4 terminals	5.5	V
Input Voltage	V <sub>IN1</sub>	RSTb, SCL, SDA, OSC, EN Terminals	-0.3 to V <sub>DD</sub> +0.3	V
Power Dissipation	P <sub>dmax</sub>	SSOP14	250	mW
Operating Temperature	T <sub>opr</sub>		-40 to +85	°C
Storage Temperature	T <sub>stg</sub>		-55 to +125	°C

Note1) V<sub>SS</sub> = 0V to all conditions

Note2) If the LSI was used out of the absolute maximum ratings, LSI is damaged completely and the reliability becomes poor. The LSI is used on the electrical characteristics is recommended strongly for normal operation.

## ■ RECOMMENDED OPERATING CONDITION (Ta= 25°C)

PARAMETERS	SYMBOL	CONDITIONS	MIN	TYP	MAX	Unit
Power voltage	V <sub>DD</sub>		1.8	-	5.5	V

## ■ DC ELECTRICAL CHARACTERISTICS(V<sub>DD</sub>=1.8V / 3.0V / 5.5V, Ta= 25°C)

PARAMETERS	SYMBOL	CONDITIONS	MIN	TYP	MAX	Unit
------------	--------	------------	-----	-----	-----	------

### Input

Input"H"Level Voltage1	V <sub>IH1</sub>	SCL, SDA1	0.7V <sub>DD</sub>	-	V <sub>DD</sub>	V	
Input"H"Level Voltage2	V <sub>IH2</sub>	RSTb, EN	0.8V <sub>DD</sub>	-	V <sub>DD</sub>	V	
Input"L"Level Voltage1	V <sub>IL1</sub>	SCL, SDA	0	-	0.3V <sub>DD</sub>	V	
Input"L"Level Voltage2	V <sub>IL2</sub>	RSTb, EN	0	-	0.2V <sub>DD</sub>	V	
Input"H"Level Current	I <sub>IH</sub>	RSTb, SCL V <sub>IN</sub> = V <sub>DD</sub>	-	-	5.0	μA	
Input"L"Level Current	I <sub>IL</sub>	RSTb, SCL, SDA V <sub>IN</sub> =0V	-5.0	-	-	μA	
Pull-up Resistance Current	I <sub>P</sub>	EN	V <sub>DD</sub> =1.8V	-	1.8	3.5	μA
			V <sub>DD</sub> =3.0V	-	8.0	12	
			V <sub>DD</sub> =5.5V	-	27	40	

### Output

Output Off Leak Current	I <sub>OFFH</sub>	LED1~4: V <sub>O</sub> =5.5V, EN=0V	-	-	6.0	μA	
Output"H"Level Voltage(1)	V <sub>OH(1)</sub>	DATAOUT, I <sub>O</sub> =-0.1mA	0.8V <sub>DD</sub>	-	-	V	
Output"L"Level Voltage(1)	V <sub>OL(1)</sub>	DATAOUT, I <sub>O</sub> =0.1mA	-	-	0.2V <sub>DD</sub>	V	
Output"L"Level Voltage(2)	V <sub>OL(2)</sub>	SDA	V <sub>DD</sub> =3.0V, I <sub>O</sub> =3.0mA	-	-	0.4	V
			V <sub>DD</sub> =5.5V, I <sub>O</sub> =3.0mA	-	-	0.4	
Output"L"Level Voltage(3)	V <sub>OL(3)</sub>	LED1~4	V <sub>DD</sub> =1.8V, I <sub>O</sub> =10mA	-	-	0.5	V
			V <sub>DD</sub> =3.0V, I <sub>O</sub> =30mA	-	-	0.5	
			V <sub>DD</sub> =5.5V, I <sub>O</sub> =30mA	-	-	0.5	

### Frequency

Oscillation Frequency	f <sub>OSC(1)</sub>	FC <sub>1</sub> =0, FC <sub>0</sub> =0	0.7	1.0	1.3	MHz
	f <sub>OSC(2)</sub>	FC <sub>1</sub> =0, FC <sub>0</sub> =1	0.84	1.2	1.56	MHz
	f <sub>OSC(3)</sub>	FC <sub>1</sub> =1, FC <sub>0</sub> =0	1.54	2.2	2.86	MHz
	f <sub>OSC(4)</sub>	FC <sub>1</sub> =1, FC <sub>0</sub> =1	0.56	0.8	1.04	MHz

### General Characteristics

Operating Current	I <sub>DD</sub>	PWM DUTY: 64/256 Output Open, FC <sub>1</sub> =0, FC <sub>0</sub> =0	V <sub>DD</sub> =1.8V	-	100	130	μA
			V <sub>DD</sub> =3.0V	-	120	160	
			V <sub>DD</sub> =5.5V	-	170	230	
Operating Current at OFF state	I <sub>NOP</sub>	Output Open	V <sub>DD</sub> =1.8V	-	-	1	μA
			V <sub>DD</sub> =3.0V	-	-	1	
			V <sub>DD</sub> =5.5V	-	-	1	

## ■ AC ELECTRICAL CHARACTERISTICS(V<sub>DD</sub>=1.8V / 3.0V / 5.5V, Ta= 25°C)

PARAMETERS	SYMBOL	CONDITIONS	MIN	TYP	MAX	Unit
<b>I<sup>2</sup>C Bus Timing (V<sub>DD</sub>=3.0V / 5.5V)</b>						
SCL Clock Frequency f <sub>SCL</sub>		SCL	-	-	400	kHz
Hold Time(Repeat) "START" Condition	t <sub>HD;STA</sub>	SCL, SDA	0.6	-	-	us
SCL clock "L" Pulse width	t <sub>LOW</sub>	SCL	1.3	-	-	us
SCL clock "H" Pulse width	t <sub>HIGH</sub>	SCL	0.6	-	-	us
Repeat "START" Condition Setup Time	t <sub>SU;STA</sub>	SCL, SDA	0.6	-	-	us
Data Hold Time	t <sub>HD;DAT</sub>	SCL, SDA	0	-	0.9	us
Data Setup Time	t <sub>SU;DAT</sub>	SCL, SDA	100	-	-	ns
Rise Time 1	t <sub>r1</sub>	SCL, SDA	-	-	300	ns
Fall Time 1	t <sub>f1</sub>	SCL, SDA	-	-	300	ns
"STOP" Condition Setup Time	t <sub>SU;STO</sub>	SCL, SDA	0.6	-	-	us
Between "STOP" – "START" Bus Free Time	t <sub>BUF</sub>	SDA	1.3	-	-	us

The bus timing at 3.0V/5.5V is based on I<sup>2</sup>C fast mode.

## I<sup>2</sup>C Bus Timing(V<sub>DD</sub>=1.8V )

SCL Clock Frequency f <sub>SCL</sub>		SCL	-	-	100	kHz
HoldTime (Repeat) "START" Condition	t <sub>HD;STA</sub>	SCL, SDA	4.0	-	-	us
SCL clock "L" Pulse width	t <sub>LOW</sub>	SCL	4.7	-	-	us
SCL clock "H" Pulse width	t <sub>HIGH</sub>	SCL	4.0	-	-	us
Repeat "START" Condition Setup Time	t <sub>SU;STA</sub>	SCL, SDA	4.7	-	-	us
Data Hold Time	t <sub>HD;DAT</sub>	SCL, SDA	0	-	3.45	us
Data Setup Time	t <sub>SU;DAT</sub>	SCL, SDA	250	-	-	ns
Rise Time 1	t <sub>r1</sub>	SCL, SDA	-	-	1000	ns
Fall Time 1	t <sub>f1</sub>	SCL, SDA	-	-	300	ns
"STOP" Condition Setup Time	t <sub>SU;STO</sub>	SCL, SDA	4.0	-	-	us
Between "STOP" – "START" Bus Free Time	t <sub>BUF</sub>	SDA	4.7	-	-	us

The bus timing at 1.8V is based on I<sup>2</sup>C standard mode.

## LED Terminal Enable timing

LED Terminal Enable Time	$t_{LZL}$	LED1~4, EN, CL=10pF, RL=1K $\Omega$ *1	$V_{DD}=1.8V$	-	-	200	ns
			$V_{DD}=3.0V$	-	-	150	
			$V_{DD}=5.5V$	-	-	150	
LED Terminal Disable Time	$t_{LLZ}$		$V_{DD}=1.8V$	-	-	200	ns
			$V_{DD}=3.0V$	-	-	150	
			$V_{DD}=5.5V$	-	-	150	
Output Delay Time	$t_{DC}$	DATAOUT, CL=10pF *2	$V_{DD}=1.8V$	-	-	600	ns
			$V_{DD}=3.0V$	-	-	300	
			$V_{DD}=5.5V$	-	-	300	

## Reset Timing

Reset "L" Pulse width	$t_{RW}$	RSTb	400	-	-	ns
Reset Time	$t_R$	RSTb	1	-	-	us

## Multi Device access timing

Access Time under Multi Device Control	$t_{MA}$	SDA, DATAOUT	$V_{DD}=1.8V$	15	-	-	us
			$V_{DD}=3.0V$	4.5	-	-	
			$V_{DD}=5.5V$	4.5	-	-	

## External Clock

External clock maximum frequency	$t_{EX}$	OSC	-	-	10	MHz
External clock "L" pulse width	$t_{EXL}$	OSC	50	-	-	ns
External clock "H" pulse width	$t_{EXH}$	OSC	50	-	-	ns

## Input Timing

Rise Time 2	$t_{r2}$	EN, RSTb, OSC	-	-	1	us
Fall Time 2	$t_{f2}$	EN, RSTb, OSC	-	-	1	us

\*1 LED Enable Time, LED Disable Time

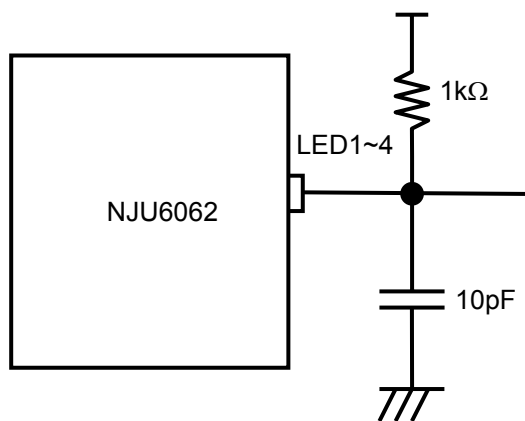

$t_{LZL}, t_{LLZ}$

\*2 Output Delay Time

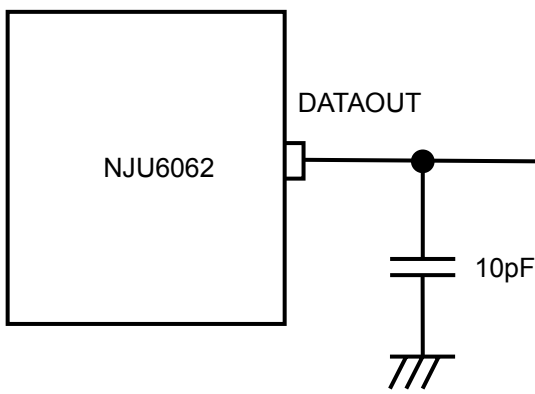

$t_{DC}$

## (1) I<sup>2</sup>C Bus timing

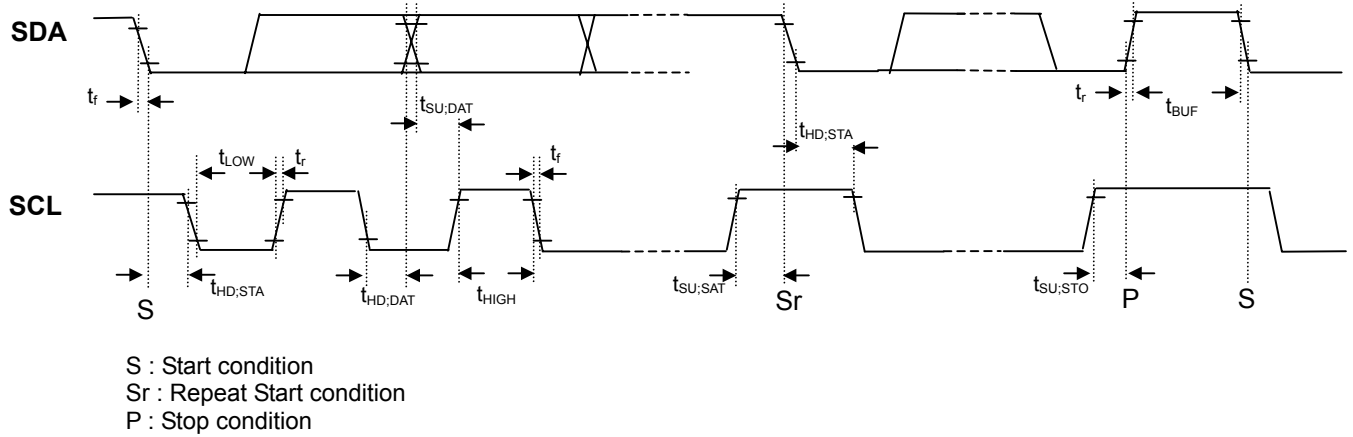

## (2) LED terminal enable timing

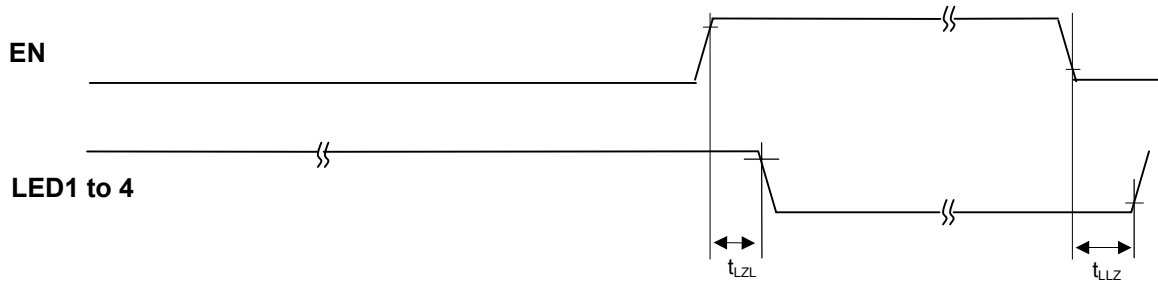

## (3) Reset timing

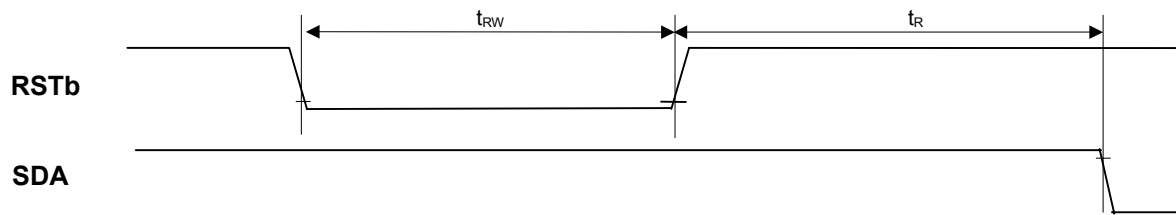

## (4) Multi Device access timing

- Set to Upper address

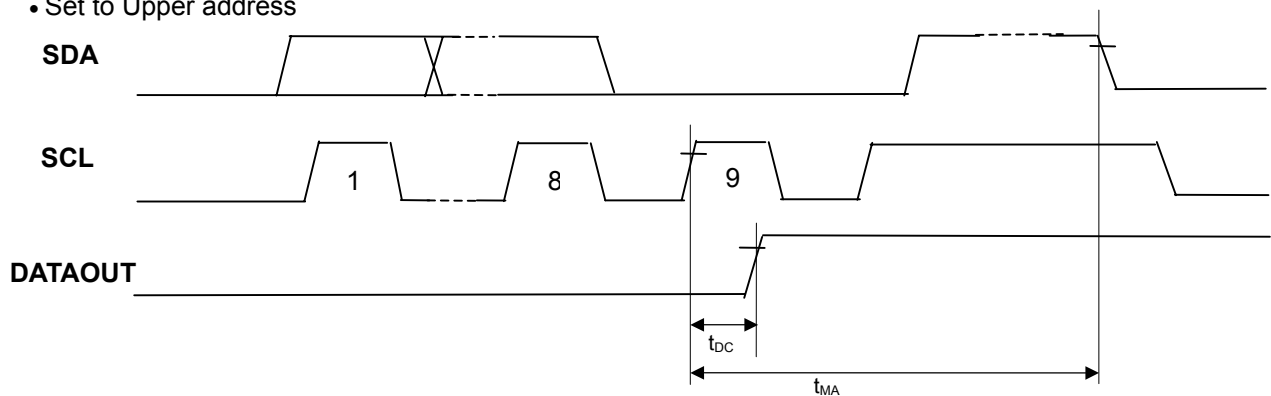

## (5) External clock

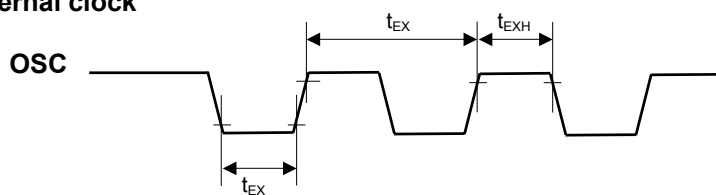

Note) All timing  $V_{IH}$ ,  $V_{IL}$  voltage level.

## APPLICATION CIRCUIT

Example 1

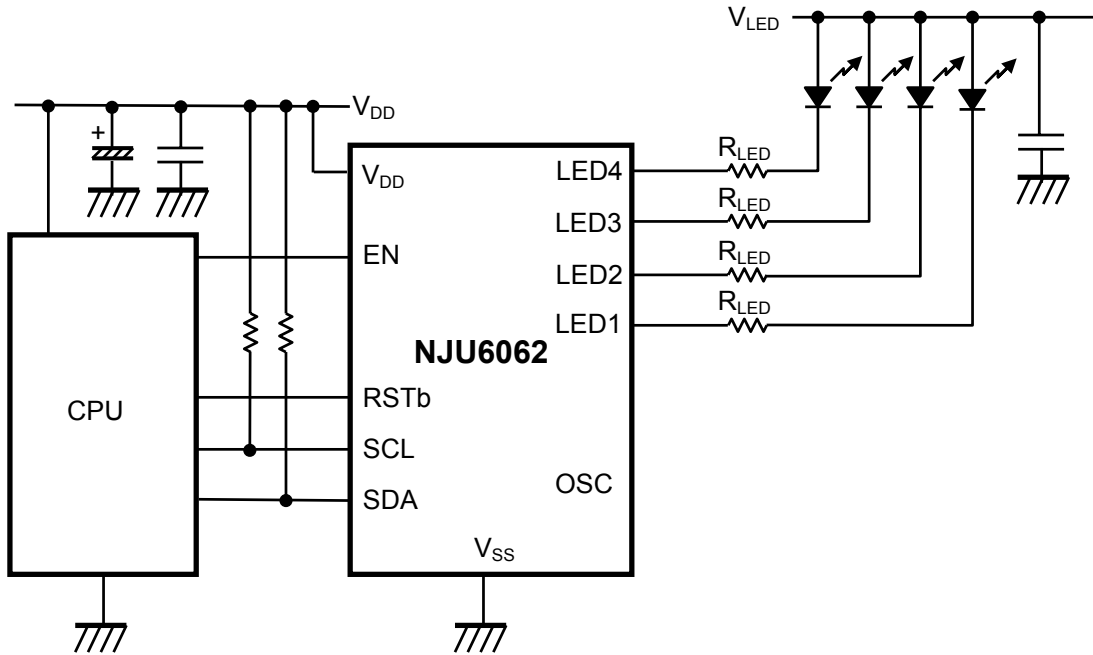

Resistor Selection

$$R_{LED} = \frac{V_{LED} - V_F - V_{OL}}{I_{LED}}$$

$R_{LED}$ : LED Current Control Resistor  
 $V_{LED}$ : LED Voltage  
 $V_F$ : LED Forward Voltage (@ $I_{LED}$ )  
 $V_{OL}$ : Output "L" Level Voltage (@ $I_{LED}$ )  
 $I_{LED}$ : LED Forward Current

Example)  $I_{LED} = 30\text{mA}$ ,  $V_{LED} = 5.0\text{V}$ ,  $V_F = 2.0\text{V}(@I_{LED} = 30\text{mA})$ ,  $V_{OL} = 0.5\text{V}$

$$R_{LED} = \frac{5.0\text{V} - 2.0\text{V} - 0.5\text{V}}{30\text{mA}} = 83.3\Omega$$

Note)  $V_F$  and  $V_{OL}$  are depended on the situation. And decide the optimum values by the actual test when  $R_{LED}$  is selected.

# NJU6062

Example 2 (Cascade connect)

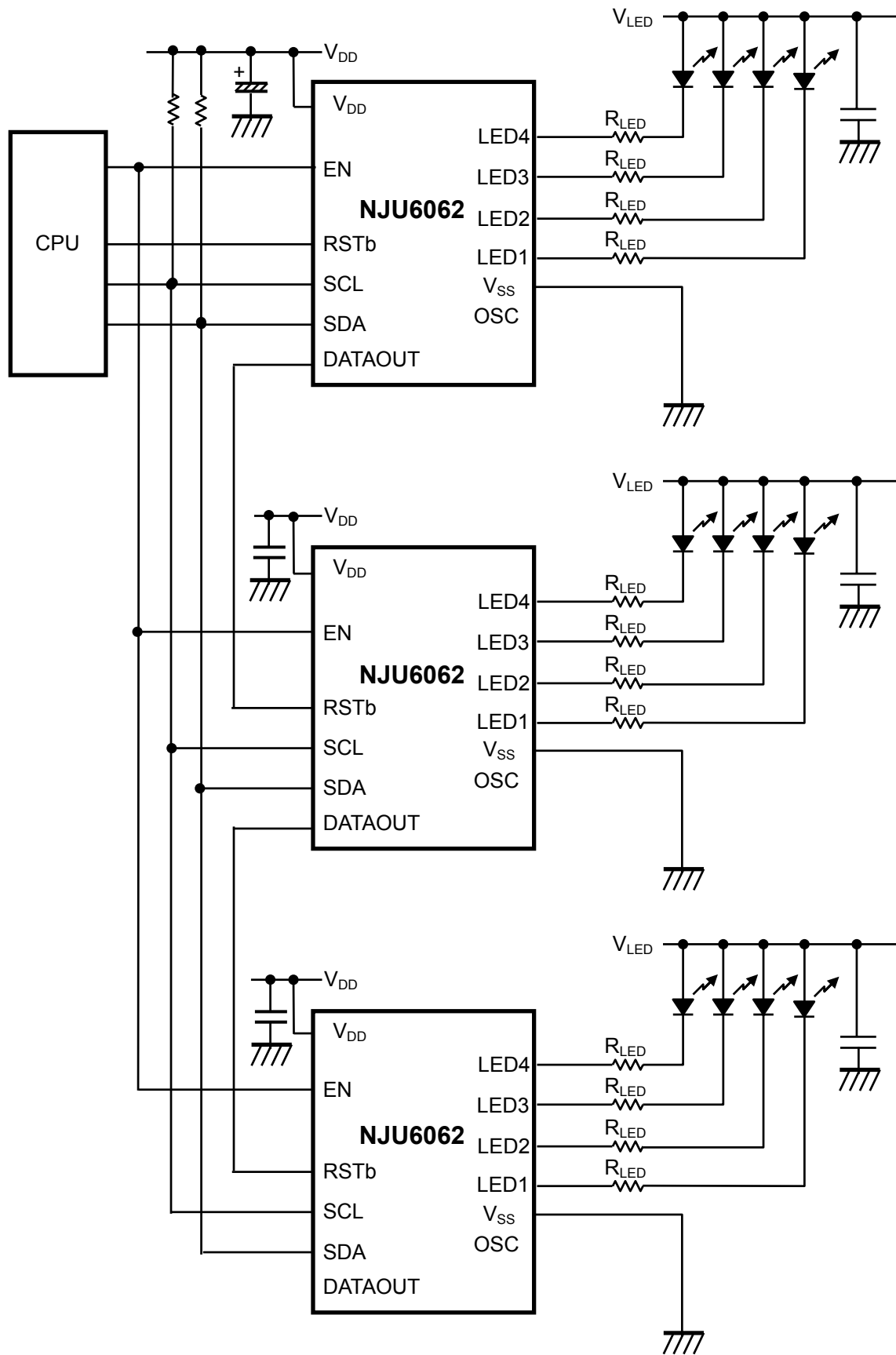

[Note] For use in the Multi Device control connection, use the same power supply for  $V_{DD}$ .

Example 3 (PWM output select )

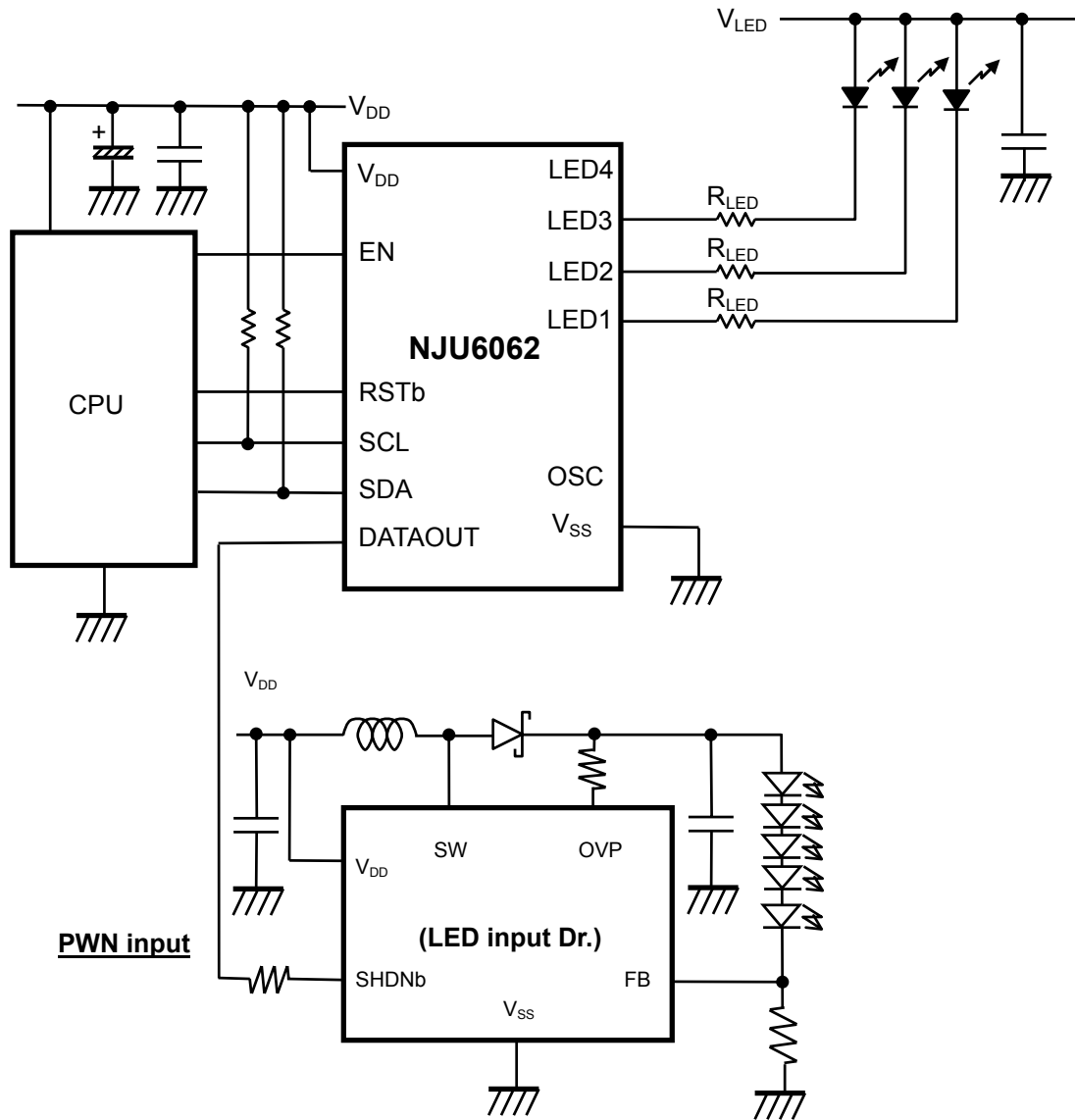

**[CAUTION]**  
 The specifications on this databook are only given for information, without any guarantee as regards either mistakes or omissions. The application circuits in this databook are described only to show representative usages of the product and not intended for the guarantee or permission of any right including the industrial rights.