

3rd. Over Tone Quartz Crystal Oscillator for 125MHz

■GENERAL DESCRIPTION

The NJU6397D is a C-MOS IC for quartz crystal oscillator consists of an oscillation amplifier and 3-state output buffer.

The frequency range is from 100 to 125MHz.

The oscillation amplifier realizes very low oscillation stop current with NAND circuit.

The 3-state output buffer is C-MOS compatible.

■PACKAGE OUTLINE



NJU6397DC-X

■FEATURES

- Operating Voltage 2.25 to 2.75V
- Maximum Oscillation Frequency 125MHz
- High Fan-out $I_{OH}/I_{OL} = 6mA @ V_{DD} = 2.5V$
- Oscillation Stop and Output Stand-by Function
- 3-State Output Buffer
- Oscillation Capacitors C_g and C_d on-chip
- Package Outline Thin-Die/Wafer
- C-MOS Technology

■PAD LOCATION

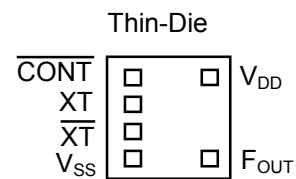

■LINE-UP TABLE

Type No.	Recommended Oscillation Frequency	Output Frequency	C_g/C_d
NJU6397 D	100 to 125MHz	f_0	8/9pF

■COORDINATES

No	Pad Name	X	Y
1	CONT	-178	231
2	XT	-178	77
3	XT	-178	-77
4	V_{SS}	-178	-231
5	F_{OUT}	206	-231
8	V_{DD}	206	231

Starting Point: Chip Center Unit[μm]

Chip Size: 0.7x0.75mm

Thin-Die Thickness(C-D): $200 \pm 20 \mu m$

Thin-Die Thickness(C-L): $140 \pm 10 \mu m$

Wafer Thickness(W-H): $200 \pm 20 \mu m$

Wafer Thickness(W-L): $140 \pm 10 \mu m$

Pad Size: 90x90 μm

Die Substrate: V_{DD} Level

■BLOCK DIAGRAM

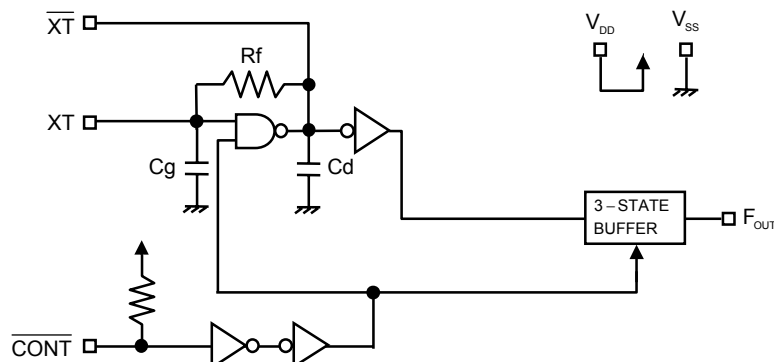

■TERMINAL DESCRIPTION

SYMBOL	FUNCTION	
$\overline{\text{CONT}}$	Oscillation and 3-state Output Buffer Control	
	$\overline{\text{CONT}}$	F_{OUT}
	H or OPEN	Output frequency f_0
	L	Oscillation Stop and High impedance Output
$\overline{\text{XT}}$	Quartz Crystal Connecting Terminals	
$\overline{\text{XT}}$		
V_{SS}	$V_{\text{SS}}=0\text{V}$	
F_{OUT}	Frequency Output	
V_{DD}	$V_{\text{DD}}=2.5\text{V}$	

■ABSOLUTE MAXIMUM RATINGS

(Ta=25°C)

PARAMETER	SYMBOL	RATING	UNIT
Supply Voltage	V_{DD}	-0.5 to +7.0	V
Input Voltage	V_{IN}	$V_{\text{SS}}-0.5$ to $V_{\text{DD}}+0.5$	V
Output Voltage	V_{O}	-0.5 to $V_{\text{DD}}+0.5$	V
Input Current	I_{IN}	± 10	mA
Output Current	I_{O}	± 25	mA
Operating Temperature Range	T_{opr}	-40 to +85	°C
Storage Temperature Range	T_{stg}	-55 to +125	°C

 Note1) If the supply voltage(V_{DD}) is less than 7.0V, the input voltage do not over the V_{DD} level.

 Note2) Decoupling capacitor should be connected between V_{DD} and V_{SS} due to the stabilized operation for the circuit.

■ELECTRICAL CHARACTERISTICS

(Ta=25°C)

PARAMETER	SYMBOL	CONDITIONS	MIN	TYP	MAX	UNIT
Operating Voltage	V _{DD}		2.25		2.75	V

 (V_{DD}=2.5V, Ta=25°C)

PARAMETER	SYMBOL	CONDITIONS	MIN	TYP	MAX	UNIT
Operating Current	I _{DD1}	D type, fosc=90MHz, C _L =15pF		13	25	mA
Oscillation Stopping Current	I _{DD2}	CONT=V _{SS} , No load		2	5	uA
Stand-by Current	I _{st}	CONT=XT=V _{SS} , No load Note3)			1	uA
Input Voltage	V _{IH}		1.75		2.5	V
	V _{IL}		0		0.75	V
Output Current	I _{OH}	V _{OH} =2.2V	6			mA
	I _{OL}	V _{OL} =0.3V	6			mA
Input Current	I _{IN}	CONT=0.8V _{DD}		7.5	12.0	uA
		CONT=0.2V _{DD}		1.2	2.0	uA
3-state Off Leakage Current	I _{oz}	CONT=V _{SS} , F _{OUT} = V _{DD} or V _{SS}			±0.1	uA
Feedback Resistance	R _f	D type		2.9		kΩ
Internal Capacitor	C _g /C _d	D type, fosc=90MHz		8/9		pF
Maximum Oscillation Frequency	F _{MAX}	D type	125			MHz
Output Signal Symmetry	SYM	C _L =15pF, @V _{DD} /2	45	50	55	%
Output Signal Rise Time	t _r	C _L =15pF, 10% to 90%		3	4	ns
Output Signal Fall Time	t _f	C _L =15pF, 90% to 10%		3	4	ns
Output Disable time	T _{PLZ}	C _L =15pF, R _{UP} =10kΩ			200	ns
Output Enable Time	T _{PZL}	C _L =15pF, R _{UP} =10kΩ			200	ns

Note3) Excluding input current on CONT Terminal.

MEASUREMENT CIRCUITS

(1) Output Signal Symmetry ($C_L=15\text{pF}$)

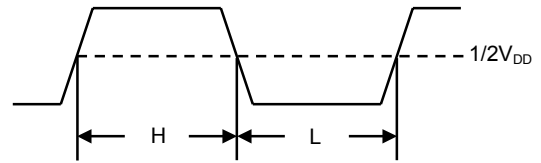
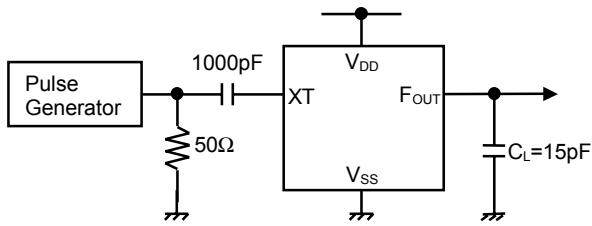

(2) Output Signal Rise/Fall Time ($C_L=15\text{pF}$)

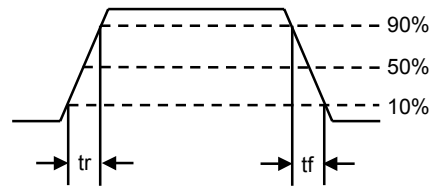
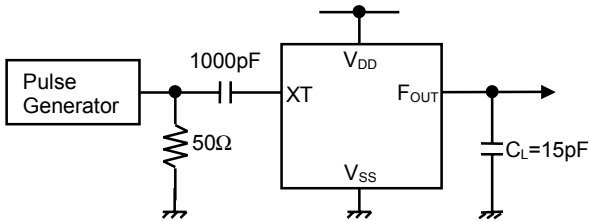

(3) Output Disable/Enable Time ($C_L=15\text{pF}, R_{UP}=10\text{k}\Omega$)

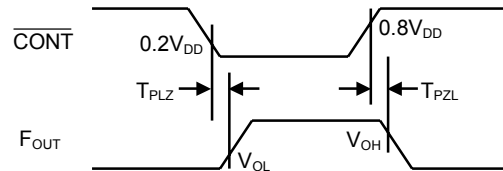
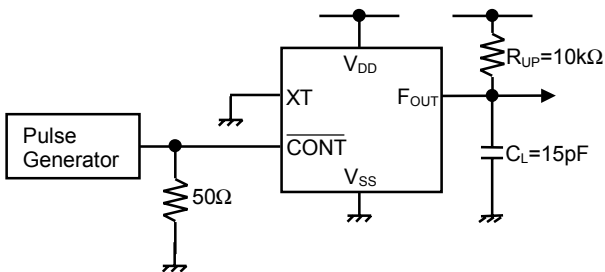

[CAUTION]
 The specifications on this data book are only given for information, without any guarantee as regards either mistakes or omissions. The application circuits in this data book are described only to show representative usages of the product and not intended for the guarantee or permission of any right including the industrial rights.