

## 4CH VIDEO AMPLIFIER WITH SW&SD/ HD LPF

### ■ GENERAL DESCRIPTION

The **NJM2525** is 4ch video amplifier with SD/HD LPF.

The **NJM2525** includes 2in-1out selector for the composite and component signal. The isolation amplifier eliminates the common mode noise from external equipment.

The **NJM2525** is suitable for the AV equipment such as the home theater systems and AV receivers that switch the internal Video signal and the external Video signal.

### ■ PACKAGE OUTLINE



**NJM2525V**

### ■ FEATURES

- Operating Voltage 4.5 to 5.5V
- SD/ HD LPF 6.75MHz/ 13.5MHz/ 30MHz
- 6dB amplifier
- 75Ω Driver Circuit
- Y/C MIX Circuit
- Isolation amplifier
- Power Save Circuit
- Bipolar Technology
- Package Outline SSOP32

### ■ BLOCK DIAGRAM

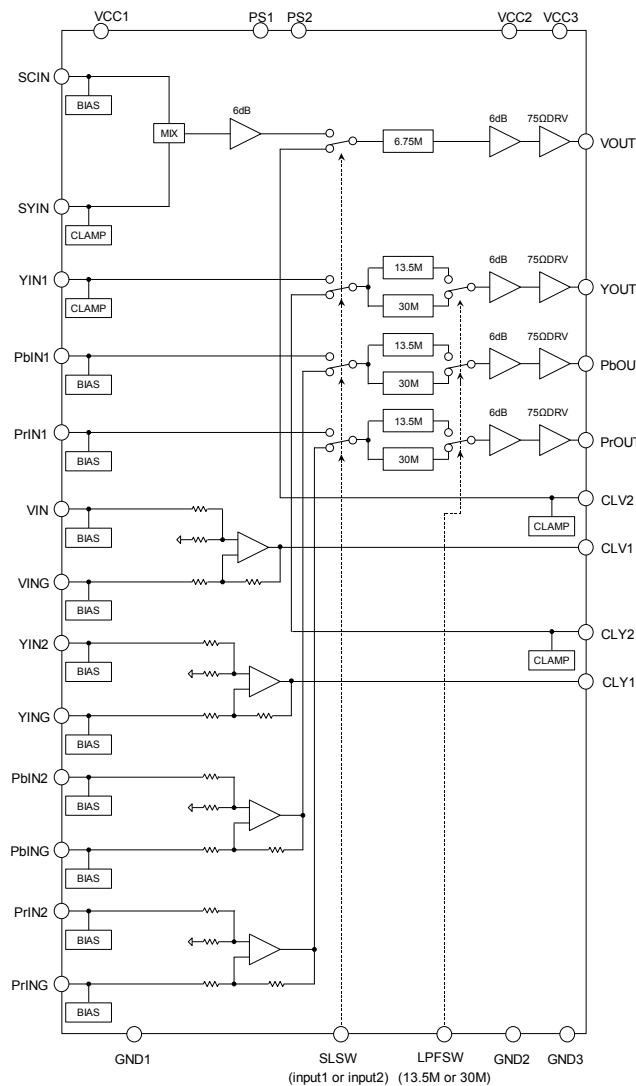

# NJM2525

## ■ PIN CONFIGURATION (SSOP32)

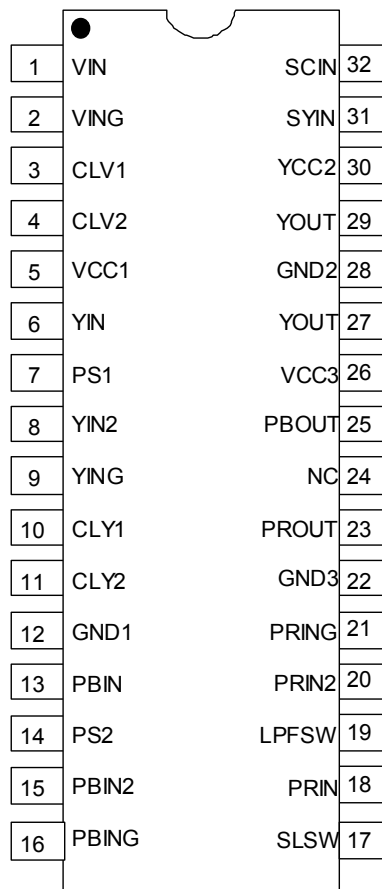

No.	Symbol	Function	No.	Symbol	Function
1	VIN	V input	17	SLSW	Input control switch
2	VING	VGND input	18	PRIN	PR input
3	CLV1	V isolation output	19	LFPSW	LPF control switch
4	CLV2	V isolation input	20	PRIN2	PR input 2
5	VCC1	Power Supply Terminal 1	21	PRING	PRGND input
6	YIN	Y input	22	GND3	GND 3
7	PS1	Power Save 1	23	PROUT	PR output
8	YIN2	Y input 2	24	NC	No Connection
9	YING	YGND input	25	PBOUT	PB output
10	CLY1	Y isolation output	26	VCC3	Power Supply Terminal 3
11	CLY2	Y isolation input	27	YOUT	Y output
12	GND1	GND 1	28	GND2	GND 2
13	PBIN	PB input	29	VOUT	V output
14	PS2	Power Save 2	30	VCC2	Power Supply Terminal 2
15	PBIN2	PB input 2	31	SYIN	SY input
16	PBING	PBGND input	32	SCIN	SC input

## ■ ABSOLUTE MAXIMUM RATINGS (Ta=25°C)

PARAMETER	SYMBOL	RATINGS	UNIT
Supply Voltage	V <sup>+</sup>	10.0	V
Power Dissipation	P <sub>D</sub>	1250 (Note )	mW
Operating Temperature Range	T <sub>opr</sub>	-40 to +85	°C
Storage Temperature Range	T <sub>stg</sub>	-40 to +150	°C

(Note) At on a board of EIA/JEDEC specification. (114.3 x 76.2 x 1.6mm 2 layers, FR-4)

## ■ RECOMMENDED OPEARATING CONDITION (Ta=25°C)

PARAMETER	SYMBOL	TEST CONDITION	MIN.	TYP.	MAX.	UNIT
Operating Voltage	V <sub>opr</sub>		4.5	5.0	5.5	V

## ■ ELECTRICAL CHARACTERISTICS (Ta=25°C, V<sup>+</sup>=5V, R<sub>L</sub>=150Ω)

PARAMETER	SYMBOL	TEST CONDITION	MIN.	TYP.	MAX.	UNIT
Operating Current	I <sub>CC</sub>	No Signal	-	50	65	mA
Operating Current at Power Save	I <sub>save</sub>	Power Save Mode	-	0.6	1.2	mA
Maximum Output Voltage Swing	V <sub>om</sub>	V <sub>in</sub> =100kHz, Sine Signal, THD=1%	2.2	-	-	V <sub>p-p</sub>
Voltage Gain1	G <sub>v1</sub>	(Note 7)V <sub>in</sub> =1MHz, 1.0V <sub>p-p</sub> , Sine Signal	5.6	6.1	6.6	dB
Voltage Gain2	G <sub>v2</sub>	(Note 3)V <sub>in</sub> =3.58MHz,0.3V <sub>pp</sub> ,Sine Signal	5.6	6.1	6.6	dB
Gain Difference Between channel	ΔG <sub>v1</sub>	(Note 1) V <sub>in</sub> =1MHz, 1.0V <sub>p-p</sub> ,Sine Signal	-0.2	0	+0.2	dB
Low Pass Filter Characteristic 1	G <sub>fy</sub> 6.75M	(Note 2) 6.75MHz/1MHz, 1.0V <sub>p-p</sub> Sine Signal	-1.0	0	1.0	dB
	G <sub>fy</sub> 108M	(Note 2) 108MHz/1MHz, 1.0V <sub>p-p</sub> Sine Signal	-	-40.0	-24.0	dB
Low Pass Filter Characteristic 2	G <sub>fc</sub> 6.75M	(Note 3)6.75MHz/3.58MHz, 0.3V <sub>p-p</sub> Sine Signal	-1.0	0	1.0	dB
	G <sub>fc</sub> 108M	(Note 3) 108MHz/3.58MHz, 0.3V <sub>p-p</sub> Sine Signal	-	-40.0	-24.0	dB
Low Pass Filter Characteristic 3	G <sub>fSD</sub> 13.5M	(Note 4) 13.5MHz/1MHz, 1.0V <sub>p-p</sub> , Sine Signal	-1.0	0	1.0	dB
	G <sub>fSD</sub> 108M	(Note 4) 108MHz/1MHz, 1.0V <sub>p-p</sub> , Sine Signal	-	-40.0	-24.0	dB
Low Pass Filter Characteristic 4	G <sub>fHD</sub> 30M	(Note 4) 30MHz/1MHz, 1.0V <sub>p-p</sub> , Sine Signal	-1.0	0	1.0	dB
	G <sub>fHD</sub> 148M	(Note 4) 148MHz/1MHz, 1.0V <sub>p-p</sub> , Sine Signal	-	-40.0	-24.0	dB
Differential Gain	DG	(Note 5) V <sub>in</sub> =1.0V <sub>p-p</sub> , 10step Video Signal	-	0.5	-	%
Differential Phase	DP	(Note 5) V <sub>in</sub> =1.0V <sub>p-p</sub> , 10step Video Signal	-	0.5	-	deg
S/N Ratio1	SN1	(Note 2) V <sub>in</sub> =1.0V <sub>p-p</sub> , 100% White video signal, R <sub>L</sub> =75Ω, 100KHz to 6MHz	-	70	-	dB
S/N Ratio2	SN2	(Note 4) V <sub>in</sub> =1.0V <sub>p-p</sub> , 100% White video signal, R <sub>L</sub> =75Ω, 100KHz to 6MHz,	-	80	-	dB
S/N Ratio3	SN3	(Note 6) V <sub>in</sub> =1.0V <sub>p-p</sub> , 100% White video signal, R <sub>L</sub> =75Ω, 100KHz to 6MHz,	-	75	-	dB
Common Mode Noise Rejection Ratio	CMR	(Note 4) V <sub>in</sub> =20KHz, V <sub>in</sub> =1V <sub>p-p</sub> ,Sine Signal	-	-55	-	dB
Cross Talk	CT	V <sub>in</sub> =4.43MHz, V <sub>in</sub> =1V <sub>p-p</sub> ,Sine Signal	-	-60	-	dB

(Note 1) YOUT/ PbOUT/ PrOUT (Note 2) SCIN,SYIN-VOUT

(Note 3) SCIN – VOUT (Note 4) YIN-YOUT,PbIN-PbOUT,PrIN-PrOUT

# NJM2525

(Note 5) SYIN – VOUT, YIN – YOUT (Note 6)VIN-VOUT,YIN2-YOUT,PbIN2-PbOUT,PrIN2-PrOUT

(Note 7) SYIN/VIN - VOUT,YIN1/YIN2 - YOUT,PbIN1/PbIN2 - PbOUT,PrIN1/PrIN2 - PrOUT

## ■ ELECTRICAL CHARACTERISTICS (Ta=25°C, V<sup>+</sup>= 5V, R<sub>L</sub>=150Ω)

PARAMETER	SYMBOL	TEST CONDITION	MIN.	TYP.	MAX.	UNIT
SW Voltage High Level	VthH		2.0	-	V <sup>+</sup>	V
SW Voltage Low Level	VthL		0	-	1.0	V
Switch inflow current High Level	IthH	V <sub>SLSW</sub> =V <sub>LPFSW</sub> =V <sub>PS1</sub> =V <sub>PS2</sub> =5V	-	-	120	μA
Switch inflow current Low Level	IthL	V <sub>SLSW</sub> =V <sub>LPFSW</sub> =V <sub>PS1</sub> =V <sub>PS2</sub> =0.3V	-	-	8.0	μA

## ■ CONTROL TERMINAL

PARAMETER	STATUS	NOTE
PS1 (Power Save1)	H	(SY, V, SC) Power Save: OFF, Active
	L	(SY, V, SC) Power Save: ON, Mute
	OPEN	(SY, V, SC) Power Save: ON, Mute
PS2 (Power Save2)	H	(Y, Pb, Pr) Power Save: OFF, Active
	L	(Y, Pb, Pr) Power Save: ON, Mute
	OPEN	(Y, Pb, Pr) Power Save: ON, Mute
S L S W (Y/Pb/PrOUT)	H	YIN2/PbIN2/PrIN2/VIN
	L	YIN1/PbIN1/PrIN1/SCIN/SYIN
	OPEN	YIN1/PbIN1/PrIN1/SCIN/SYIN
L P F S W ( L P F )	H	30MHz LPF
	L	13.5MHz LPF
	OPEN	13.5MHz LPF

## MEASUREMENT CIRCUIT

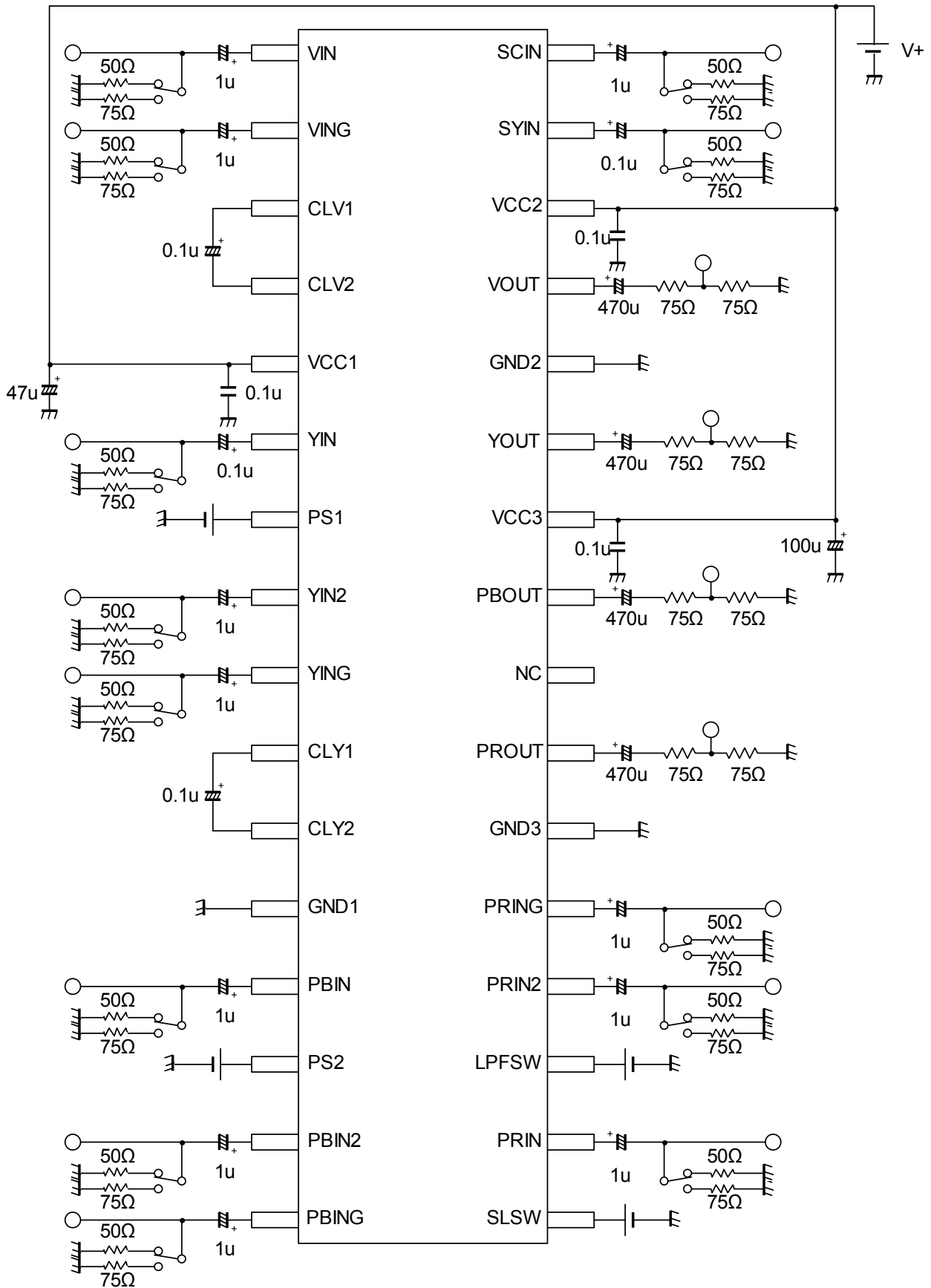

# NJM2525

## APPLICATION CIRCUIT

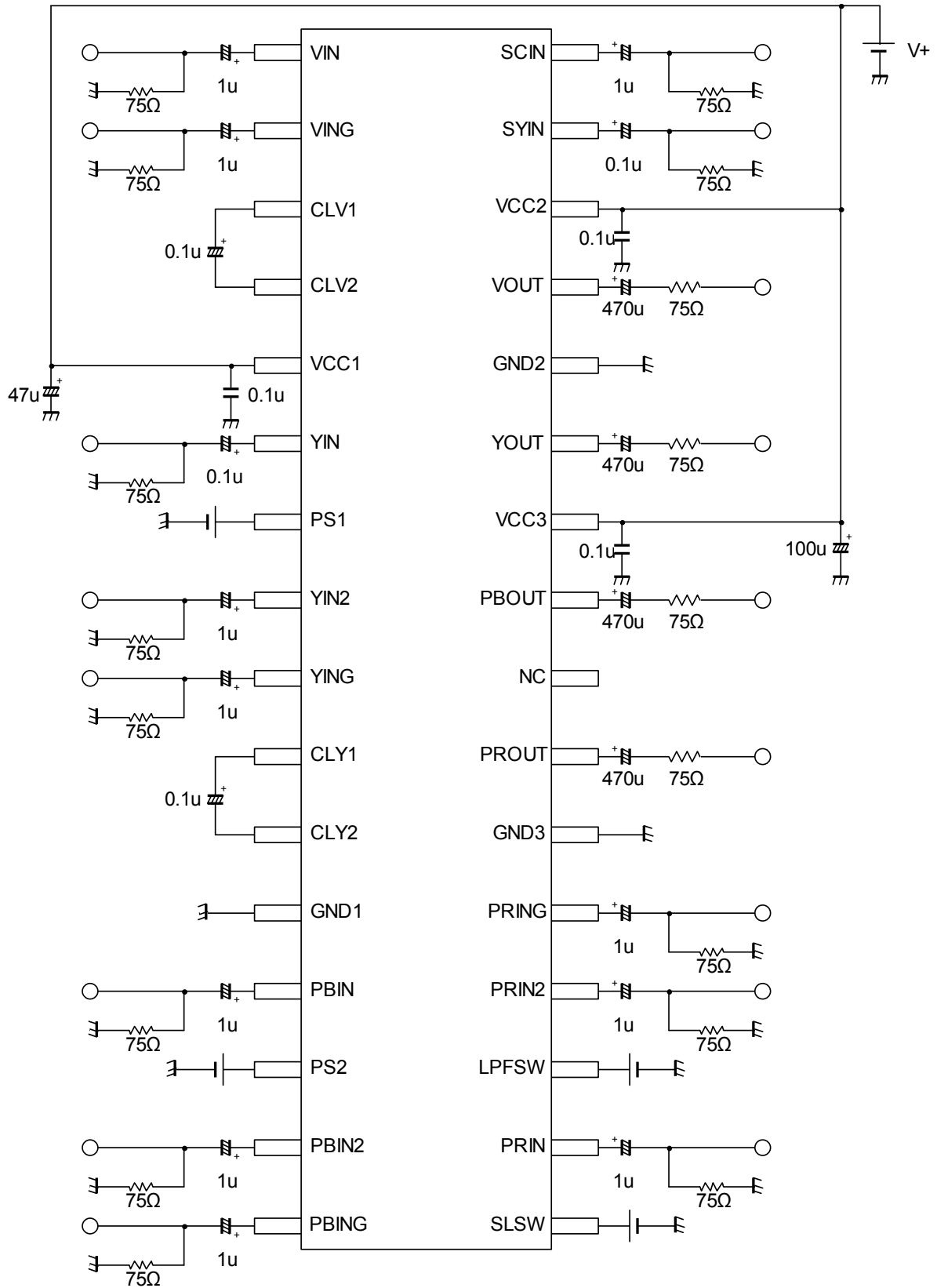

## ■ TERMINAL DESCRIPTION

PIN No.	SYMBOL	FUNCTION	EQUIVALENT CIRCUIT	TERMINAL VOLTAGE
1 2 8 9 13 15 16 18 20 21 32	VIN VING YIN2 YING PBIN PBIN2 PBING PRIN PRIN2 PRING SCIN	V input VGND input Y input 2 YGND input PB input PB input2 PBGND input PR input PR input 2 PRGND input SC input		2.5V
3 10	CLV1 CLY1	V isolation output Y isolation output		2.5V
4 6 11 31	CLV2 YIN CLY2 SYIN	V isolation input Y input Y isolation input SY input		1.7V
7 14 17 19	PS1 PS2 SLSW LPFSW	Power Save 1 Power Save 2 Input control switch LPF control switch		-

# NJM2525

PIN No.	SYMBOL	FUNCTION	EQUIVALENT CIRCUIT	TERMINAL VOLTAGE
23	PROUT	PR output		2.5V
25	PBOUT	PB output		2.5V
27	YOUT	Y output		1.4V
29	VOUT	V output		1.4V

**[CAUTION]**

The specifications on this databook are only given for information, without any guaranteed as regards either mistakes or omissions. The application circuits in this databook are described only to show representative usages of the product and not intended for the guarantee or permission of any right including the industrial rights.