

# Single-phase DC Brushless Motor Driver IC

## ■ GENERAL DESCRIPTION

The NJU7333 is a single-phase DC brushless motor driver IC for small fan-motor and high power applications. It features MOS-FET driver circuit for better saturation characteristics. Slew rate of amplifiers and feedback resistors are optimized to achieve low-noise motor operation. Maximum output current is 500mA. The NJU7333 includes frequency generator (FG) output, lock detect (with auto recovery circuit), and a thermal shutdown circuit.

## ■ PACKAGE OUTLINE

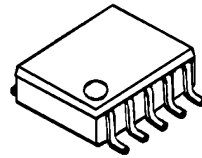

NJU7333R

## ■ FEATURES

- Operating Voltage  $V_{DD}=2.4 \sim 5.5V$
- FG Output
- Internal Lock Detect / Auto Recovery Circuit
- Internal Thermal Shutdown Circuit
- Low Operating Current  $I_{DD}=3mA$  (Typ.)
- Low Saturation Output Voltage  
 $V_{sat}=\pm 0.35V$  @  $I_o=\pm 500mA$
- C-MOS Technology
- Package Outline VSP10

## ■ BLOCK DIAGRAM

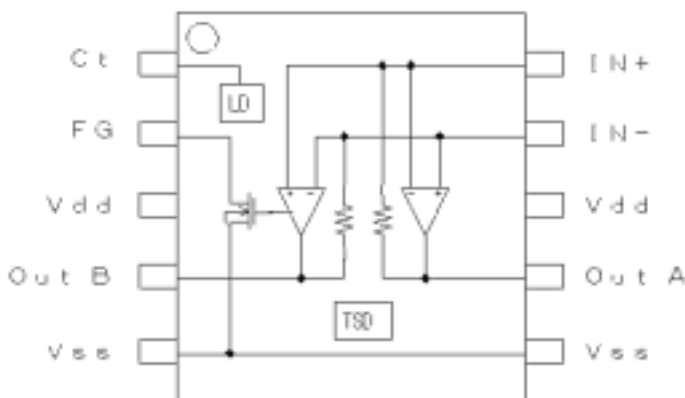

## ■ PIN FUNCTION

- 1: Ct
- 2: FG
- 3: Vdd
- 4: OUT B
- 5: Vss
- 6: Vss
- 7: OUT A
- 8: Vdd
- 9: IN-
- 10: IN+

# NJU7333

Preliminary

## ■ ABSOLUTE MAXIMUM RATINGS

(Ta=25°C)

PARAMETER	RATINGS	SYMBOL (unit)	NOTE
Supply Voltage	+7.0	V <sub>DD</sub> (V)	
Input Voltage	-0.3 ~ V <sub>DD</sub> +0.3	V <sub>ID</sub> (V)	
Output Current (Peak)	1.0	I <sub>O PEAK</sub> (A)	
Operating Temperature Range	-40 ~ +85	T <sub>opr</sub> (°C)	
Storage Temperature Range	-50 ~ +150	T <sub>stg</sub> (°C)	
Power Dissipation	400	P <sub>D</sub> (mW)	Device itself

## ■ RECOMMENDED OPERATING CONDITIONS

(V<sub>DD</sub>=5V, Ta=25°C)

PARAMETER	SYMBOL	CONDITION	MIN.	TYP.	MAX.	UNIT
Supply Voltage	V <sub>DD</sub>	-	2.4	5.0	5.5	V
Operating Temperature Range	T <sub>j</sub>	-	-40	-	85	°C
Input Common Mode Voltage Range	V <sub>ICM</sub>	-	0.4	-	4.0	V
Output Current	I <sub>o</sub>	-	-	-	0.5	A

## ■ ELECTRICAL CHARACTERISTICS

(V<sub>DD</sub>=5V, T<sub>a</sub>=25°C)

PARAMETER	SYMBOL	CONDITION	MIN.	TYP.	MAX.	UNIT
<b>General</b>						
Operating Current	I <sub>DD</sub>	-	-	3.0	4.0	mA
Thermal Shutdown Temperature	T <sub>TSD</sub>	-	-	180	-	°C
Thermal Shutdown Hysteresis	T <sub>HYS</sub>	-	-	50	-	°C
<b>Hall Amplifier</b>						
Input Offset Voltage	V <sub>IO</sub>	-	-7	-	7	mV
Feedback Resistance	R <sub>F</sub>	-	22.0	27.5	33.0	kΩ
Open loop gain	A <sub>V</sub>	-	-	80	-	dB
Input Common Mode Voltage Range	V <sub>ICM</sub>	-	0.4-4.0	-	-	V
<b>Outputs</b>						
Maximum Output Voltage Range	V <sub>OH</sub>	I <sub>o</sub> =+350mA	4.65	4.75	-	V
	V <sub>OL</sub>	I <sub>o</sub> = -350mA	-	0.25	0.35	
Output Resistance	R <sub>ONH</sub>	I <sub>o</sub> =+500mA	-	0.5	-	Ω
	R <sub>ONL</sub>	I <sub>o</sub> = -500mA	-	0.5	-	
FG L Output Voltage	V <sub>FG</sub>	4pin=5V,3pin=0V, R <sub>P</sub> =10kΩ	-	-	0.3	V
FG H Leak Current	I <sub>FG-LEAK</sub>	4pin=0V,3pin=5V, R <sub>P</sub> =10kΩ	-	-	1.0	μA
<b>Lock Detect Circuits</b>						
Lock Protect Operating Voltage	V <sub>LOP</sub>	-	4.0	-	-	V
Lock Detect Discharge Current	I <sub>DCHG</sub>	-	-	1.5	-	μA
Lock Detect Discharge Current	I <sub>DCHG</sub>	-	-	0.5	-	μA
Clamp Voltage	V <sub>CL</sub>	-	-	2.6	-	V
Detect Voltage	V <sub>ID</sub>	-	-	0.6	-	V

# NJU7333

## Preliminary

### APPLICATION NOTE

The NJU7333 is a single-phase DC brushless motor driver IC featuring CMOS process. It is suitable for fan motor drivers for a small equipment such as the note personal computers.

[Application Circuit Example]

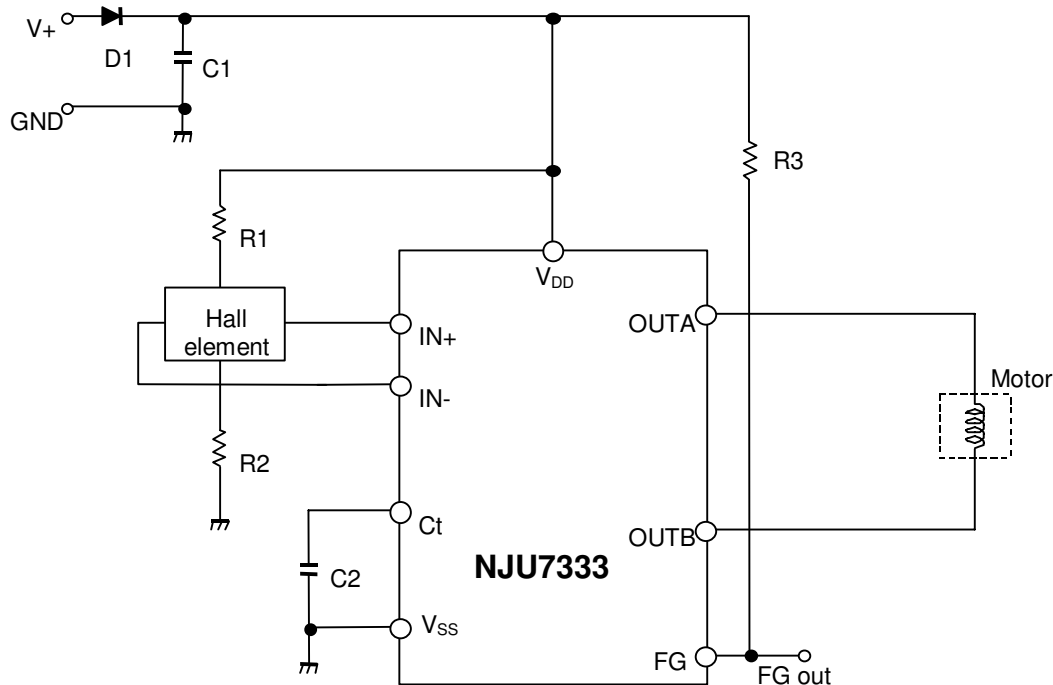

[Design Notes]

Above application example is designed for 5V operation with motor current of 500mA. It uses the following components:

Hall Elements: HW101A (AKE)

#### 1. Selection of C1 and D1:

C1 is used for a noise reduction purpose. A typical value is 0.1 $\mu$ F.

Optimize the value in actual operating conditions if necessary. D1 is a diode for protection against reverse voltage supply. Silicon rectifier diode (WO3C, 10D1 and equivalent) is appropriate.

#### 2. Lock Protection Function (Design of C2 value):

Lock Protection Function, consists of Motor Lock Detection and Auto Resume Function, is a safety feature to protect a motor and a driver circuit from fatal destruction in case of motor halt.

Motor Lock Detection detects motor halt due to irregular load conditions and then cuts motor driving current for safety operation. A value of C2 determines Lock detection time ( $T_{on}$ ) and Auto Resume Time ( $T_{off}$ ).

Lock detection time ( $T_{on}$ ) is given by:

$$T_{ON} = C2 \frac{V_{CL} - V_{ID}}{I_{CHG}} [\text{sec}]$$

Where C2 is 0.47uF:

$$T_{ON} = 0.47 \times 10^{-6} \times \frac{2.6 - 0.6}{1.5 \times 10^{-6}} = 0.62 [\text{sec}]$$

Auto Resume Time ( $T_{off}$ ) is given by:

$$T_{OFF} = C2 \frac{V_{CL} - V_{ID}}{I_{DCHG}} [\text{sec}]$$

Where C2 is 0.47uF:

$$T_{OFF} = 0.47 \times 10^{-6} \times \frac{2.6 - 0.6}{0.5 \times 10^{-6}} = 1.88 [\text{sec}]$$

In actual application, Lock detection time ( $T_{on}$ ) is affected by the mechanical time constant of a motor. Therefore, constant start up must be confirmed in actual evaluation taking operating variations (i.e. Temperature, Voltage change and so on) in consideration.

A typical value of C2 is either 0.47uF or 1uF depending on a motor.

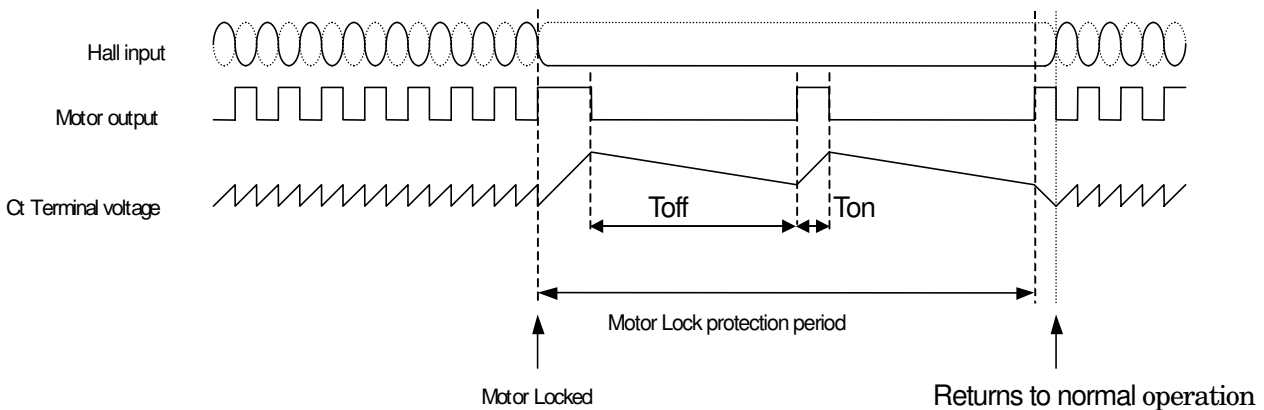

### 3. Design of hall element bias resistance (**R1 and R2**)

Hall amplifier is a differential amplifier with hysteresis characteristics (24mV typical).

The common-mode input voltage is between 0.4V and  $V_{DD}-1V$  and the input signal must be within the range. Non-excitation hall bias voltage is to be set at a half of  $V_{DD}$  for effective use of common-mode input voltage range. Therefore the same value of hall bias resistors is selected for R1 and R2.

## Preliminary

Given that the bias current is set to be 5mA by HW101A datasheet, R1 and R2 can be determined as follows:

$$R1 + R2 + R_{in} = \frac{V_{DD}}{I_{bias}} = \frac{5}{5 \times 10^{-3}} = 1k\Omega$$

$$R1 = R2 = 300\Omega$$

The output voltage of hall elements is influenced by the bias current and magnetic flux density of hall elements.

The optimum input voltage of NJU7333 is 100mVp-p and higher. With such input voltage, the highest efficiency can be obtained.

#### 4. Design of FG output resistance (**R3**)

FG Out(FG:Pin2) is a open drain output and R3 is a pull up register. A typical value of R3 is 10kΩ. The timing chart of FG Out is as follows.

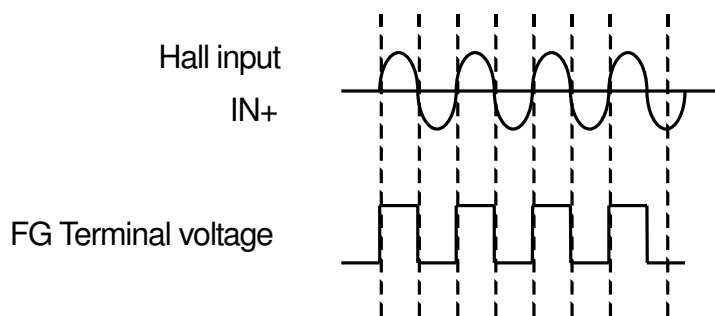

The specifications on this data book are only given for information, without any guarantee as regards either mistakes or omissions. The application circuit in this data book are described only to show representative usages of the product and not intended for the guarantee or permission of any right including the industrial rights.