

Single-phase DC Brushless Motor Driver IC

■ GENERAL DESCRIPTION

The NJU7326 is a single-phase DC brushless motor driver IC.

It features MOS-FET output for better saturation characteristics.

Slew rate of amplifiers and feedback resistors are optimized to achieve low-noise motor operation.

It is suitable for small fan-motor applications.

■ PACKAGE OUTLINE

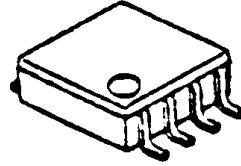

NJU7326R/RB1

■ FEATURES

- Single Supply
- Operating Voltage $V_{DD}=2.4$ to $5.5V$
- Low Operating Current
- Low Saturation Output Voltage $V_{sat}=\pm 0.35V$ @ $I_o=\pm 250mA$
- C-MOS Technology
- Package VSP8, TVSP8

■ BLOCK DIAGRAM

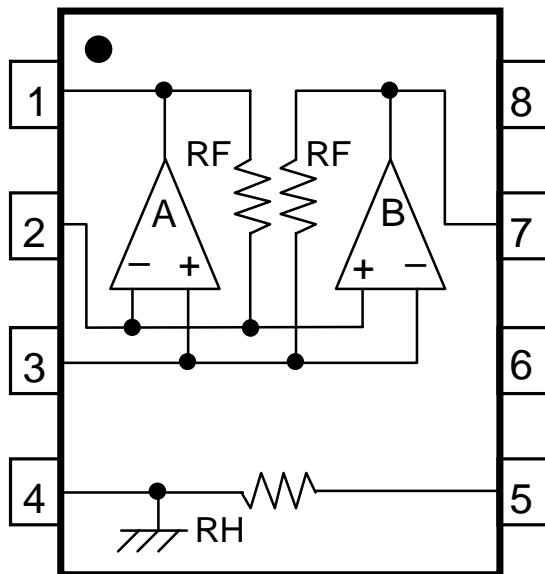

- 1 : A OUTPUT
- 2 : Reverse INPUT
- 3 : Non-Reverse INPUT
- 4 : V_{SS}
- 5 : RH
- 6 : NC
- 7 : B OUTPUT
- 8 : V_{DD}

■ ABSOLUTE MAXIMUM RATINGS

(Ta=25°C)

PARAMETER	RATINGS	SYMBOL (unit)	NOTE
Supply Voltage	+7.0	V _{DD} (V)	
Input Voltage	-0.3 to V _{DD} +0.3	V _{ID} (V)	
Storage Temperature Range	-50 to +150	T _{stg} (°C)	
Operating Temperature Range	-40 to +85	T _{opr} (°C)	
Power Dissipation	400	P _D (mW)	VSP8/TVSP (Single)

■ RECOMMENDED OPERATING CONDITION

V_{DD} = 2.4V to 5.5V

■ ELECTRICAL CHARACTERISTICS

(Ta=25°C, V_{DD}=5V)

PARAMETER	SYMBOL	CONDITION	MIN.	TYP.	MAX	UNIT
Operating Current	I _{DD}	No Load Condition : Voltage Follower V _O =2.5V : 1 circuit	-	3.0	4.0	mA
Input Offset Voltage	V _{IO}		-15	-	+15	mV
Input Common Mode Voltage Range	V _{ICM}		0.4~4.0	-	-	V
Maximum Output Voltage Range	V _{OM+}	I _O =+250mA	4.55	4.65	-	V
	V _{OM-}	I _O =-250mA	-	0.35	0.45	
Feedback Resistance	R _F	-	22.0	27.5	33.0	kΩ
Hall Bias Resistance	R _H	-	240	300	360	Ω

■ TYPICAL APPLICATION

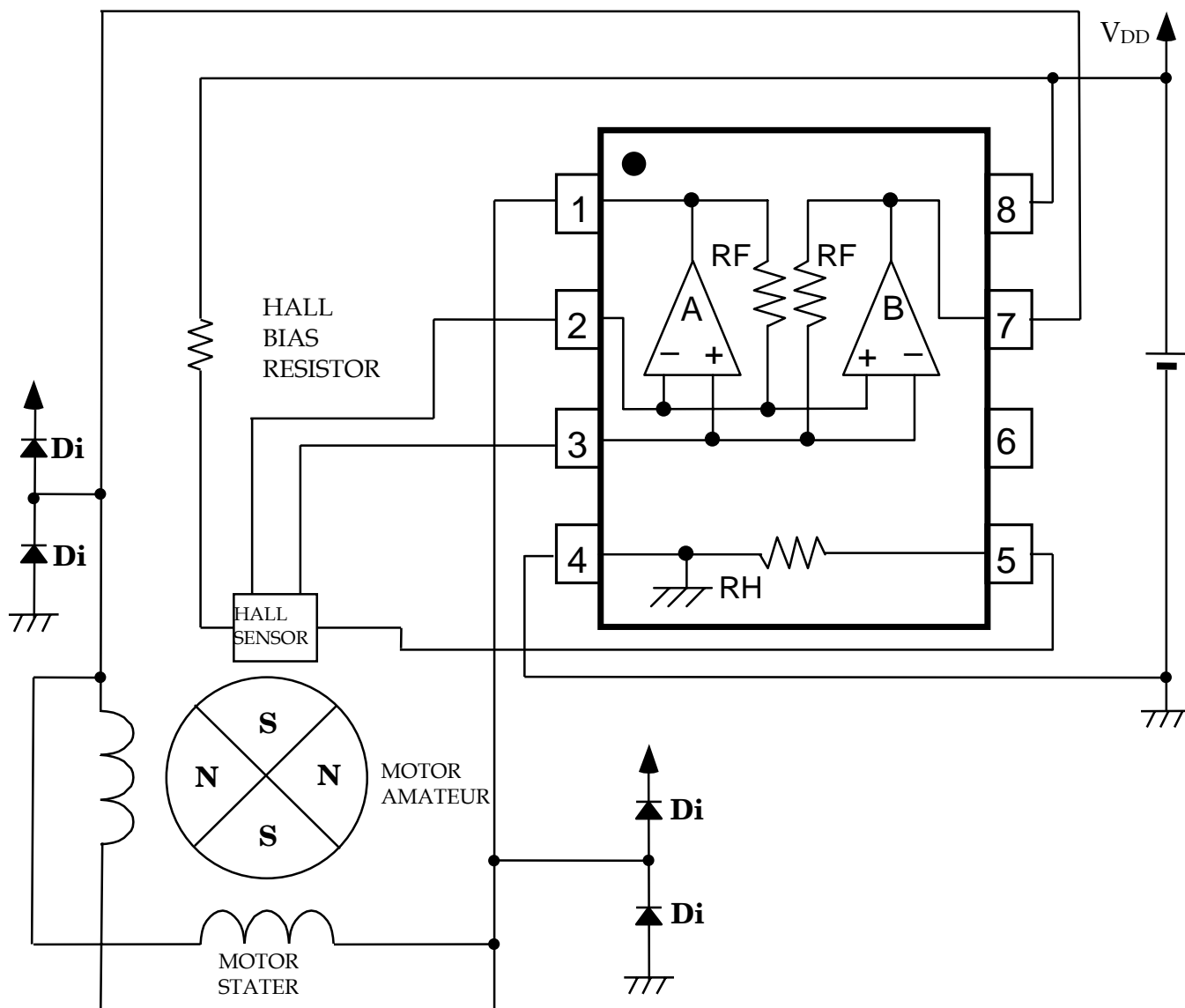

Diodes shown in the picture indicate external re-circulating diodes.

Place re-circulating diodes at output terminals depending on the inductive load.

[CAUTION]
 The specifications on this databook are only given for information, without any guarantee as regards either mistakes or omissions. The application circuits in this databook are described only to show representative usages of the product and not intended for the guarantee or permission of any right including the industrial rights.