

Single-Phase DC Brushless Motor Pre-driver IC

■ GENERAL DESCRIPTION

The NJM2660A is a Single-phase DC brushless motor pre-driver IC. It incorporates Lock Detect / Auto Protection Circuit and totem-pole pre - drivers for external power MOS-FET.

The turn ON / turn OFF ratio at Auto Protection Release was set in 1:10 easy-to-use.

Two comparators are built into NJM2660A for the temperature adjustable speed control or over current detection.

■ PACKAGE OUTLINE

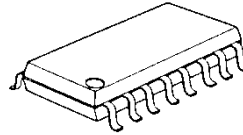

NJM2660AM

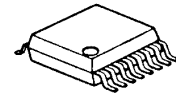

NJM2660AV

■ FEATURES

- Operating Voltage 4.5 to 30V
- Absolute Maximum Voltage 36V
- Totem-pole Output (Lower Arm)
- Internal Lock Detect /Auto Protection Release Circuit
- Lock Alarm Output Terminal
- Internal comparator 2 circuit
- Package Outline DMP16 SSOP16

■ PIN CONFIGURATION

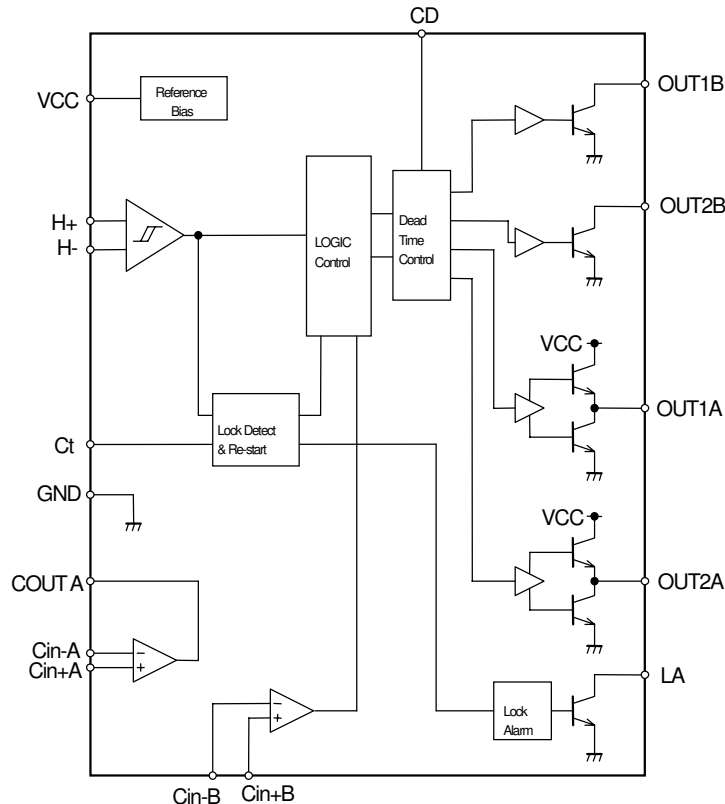

NJM2660A

■ BLOCK DIAGRAM

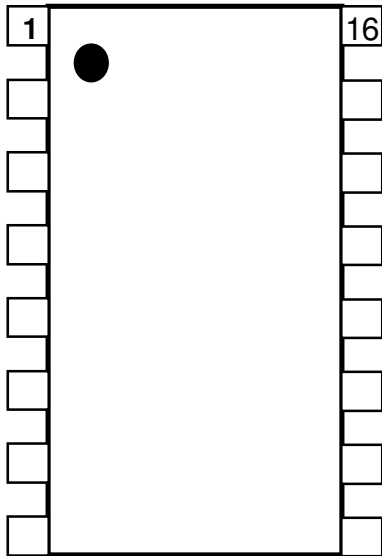

1: Vcc	9: GND
2: H1	10: Ct
3: H2	11: Cin-B
4: LA	12: Cin+B
5: COUT A	13: OUT2B
6: Cin+A	14: OUT1B
7: Cin-A	15: OUT2A
8: CD	16: OUT1A

■ ABSOLUTE MAXIMUM RATINGS

PARAMETER	SYMBOL	RATINGS	UNIT	NOTE
Supply Voltage	Vcc	36	V	-
Hall Input Voltage Range	VHcmr	-0.3 ~ Vcc	V	-
Hall Input Differential Voltage	VHdff	2	V	-
A ch Output Current	IoMA	50	mA	-
B ch Output Current	IoMB	50	mA	-
Lock Alarm Output Voltage	VLA	36	V	-
Lock Alarm Output Current	IoLA	20	mA	-
Comparator Input Voltage Range	VCcmr	-0.3 ~ Vcc	V	-
Comparator Output Voltage	VoC	36	V	-
Comparator Output Current	IoC	20	mA	-
Power Dissipation	Pd	435(DMP)	mW	Device it self
		375(SSOP)	mW	
Operating Temperature Range	Topr	-40 ~ 85	°C	-
Operating Junction Temperature Range	Tj	-40 ~ 150	°C	-
Storage Temperature Range	Tstg	-55 ~ 150	°C	-

■ RECOMMENDED OPERATING CONDITIONS

(Ta=25°C)

PARAMETER	SYMBOL	RATINGS	UNIT	NOTE
Supply Voltage	Vcc	4.5 ~ 30	V	Ct=0
Hall Input Voltage Range	Vhi	0 ~ Vcc-2	V	-
Comparator Input Voltage Range	Vci	0 ~ Vcc-2	V	-
Junction Temperature	Tj	-20 ~ 125	°C	-

■ ELECTRICAL CHARACTERISTICS

(Ta=25°C, V_{CC}=12V)

PARAMETER	SYMBOL	CONDITIONS	MIN.	TYP.	MAX.	UNIT
■ Total						
Operating Current	I _{CC}	V _{CC} =12V	-	8	12	mA
		V _{CC} =24V	-	10	15	mA
■ Input / Output						
Hall Input Hysteresis Voltage	V _{hys}	-	-	20	-	mV
Hall Input Bias Voltage	I _{hbias}	-	-	0.5	-	μA
A Upper Output Voltage	V _{OHA}	I _O =-20mA	V _{CC} -2	V _{CC} -1.7	-	V
A Lower Output Voltage	V _O LA	I _O =10mA	-	0.3	0.7	V
		I _O =50mA	-	1.8	2.2	V
B Output Voltage	V _O LB	I _O =20mA	-	0.3	0.7	V
Ach Output Crump Voltage	V _{CLMP}	V _{CC} =30V	-	16	20	V
Bch Output Leak Voltage	I _{oleak}	V _O =30V	-	1	3	μA
Dead Time	T _d	C _d =10nF	-	350	-	μs
■ Lock Detection						
Lock Protect Operation Voltage	V _{LOP}		5.0	-	-	V
Lock Alarm Output Voltage	V _{lock}	Lock Alarm ON, I _{LA} =5mA	-	-	0.5	V
Lock Alarm Leak Current	I _{LA} leak	V _{LA} =30V	-	1	3	μA
Charge Current	I _c	V _{CT} =1.5V	-	4.0	5.5	μA
Discharge Current	I _{dc}	V _{CT} =1.5V	-	0.4	0.6	μA
Charge / Discharge Current Ratio	I _c /I _{dc}	-	-	10	-	
H Level Cense Voltage	V _{ch}	-	3.0	3.3	3.6	V
Reversal Voltage	V _{cl}	-	0.70	0.85	1.00	V
Auto Protection Release ON Time	T _{on}	C _t =0.47μF	-	0.25	-	s
Auto Protection Release OFF Time	T _{off}	C _t =0.47μF	-	2.5	-	s
■ Comparator Ach						
Input Offset Voltage	V _{ioA}	-	-	2	7	mV
Input Bias Current	I _{ibA}	-	-	30	200	nA
Input Common Mode Voltage Range	V _{icmA}	-	0 ~ 10	-	-	V
Output Sink Current	I _{sink}	V _O =1.5V	6	10	-	V
Output Saturation Voltage	V _{sat}	I _{sink} =3mA	-	80	300	mV
Output Leak Current	I _{CLEAK}	V _O =30V	-	1	3	uA
■ Comparator Bch						
Input Offset Voltage	V _{ioB}	-	-	2	-	mV
Input Bias Current	I _{ibB}	-	-	30	-	nA

A charge and discharge current ratio is set in general to a minimum of 7 and a maximum of 14.

NJM2660A

TIME CHART

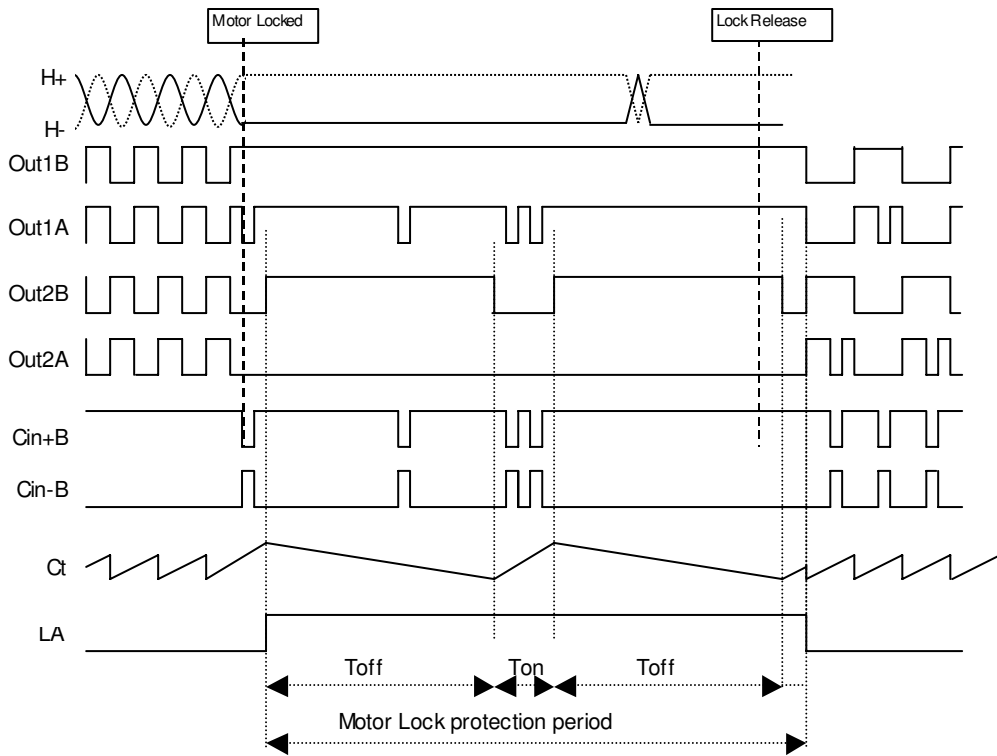

$$T_{on} = C_t \times \frac{V_{ch} - V_{cl}}{I_c} [S] \quad T_{off} = C_t \times \frac{V_{ch} - V_{cl}}{I_{dc}} [S]$$

DEAD TIME

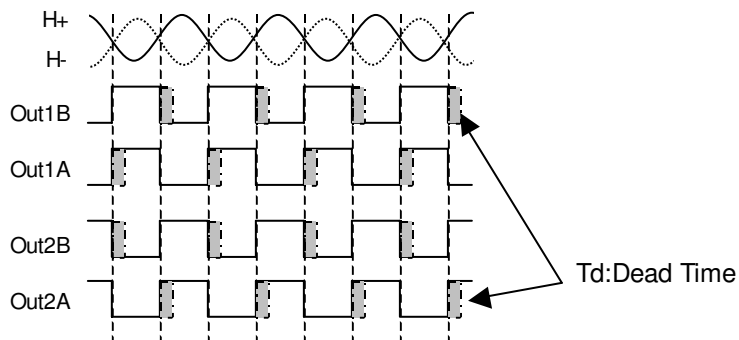

$$T_d = 35.4 \times 10^3 \times C_d [S]$$

■ TYPICAL APPLICATIONS 1

- Over Current Protection Application Circuit

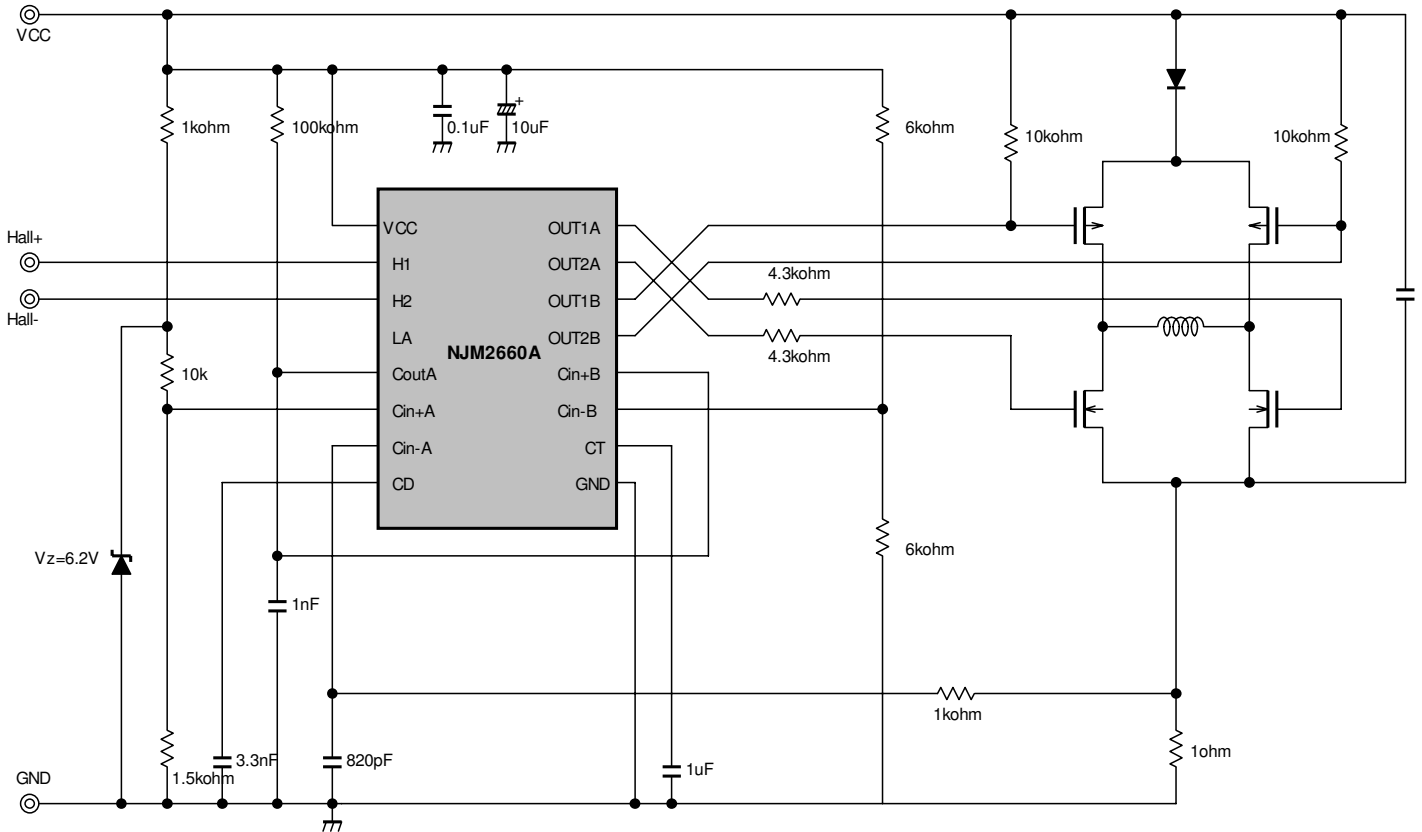

NJM2660A

TYPICAL CHARACTERISTICS

VCC vs ICC

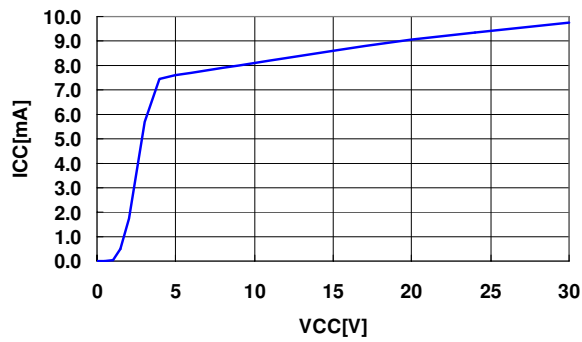

VCC vs VOH

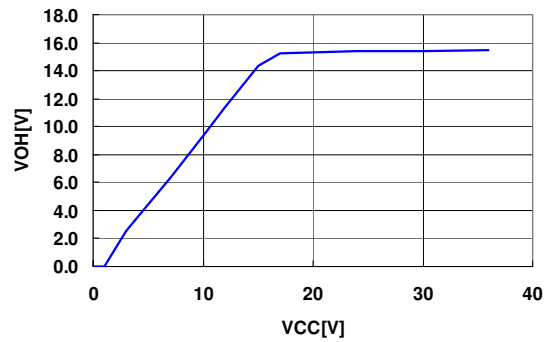

Iout vs Vsat_H(Ach)
VCC=12V

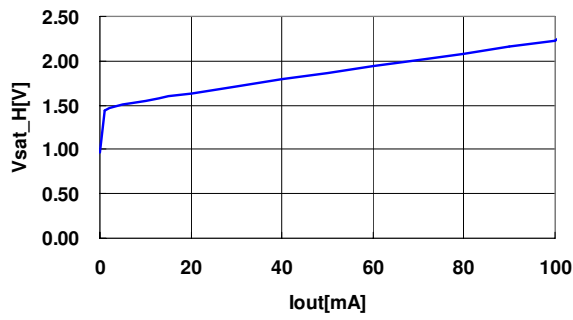

Iout vs Vsat_L(Ach)
VCC=12V

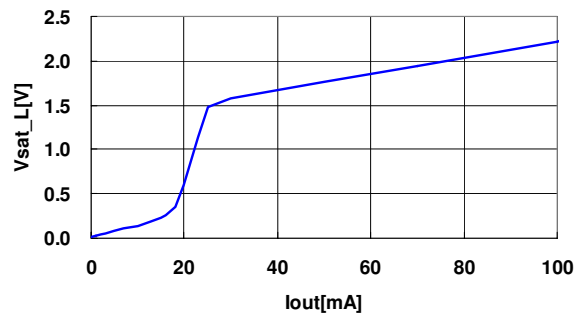

Iout vs Vsat_L(Bch)
VCC=12V

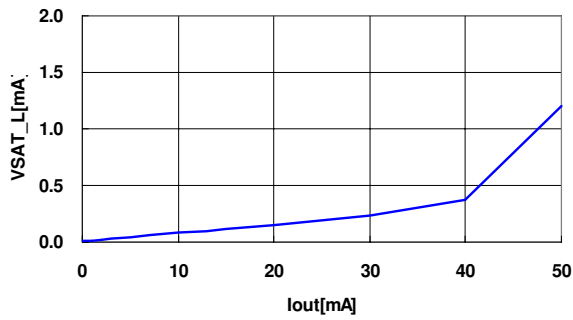

Icout vs Vcsat(Ach)
VCC=12V

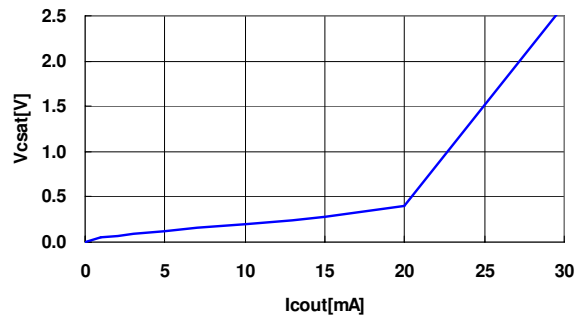

ILA vs VLA
VCC=12V

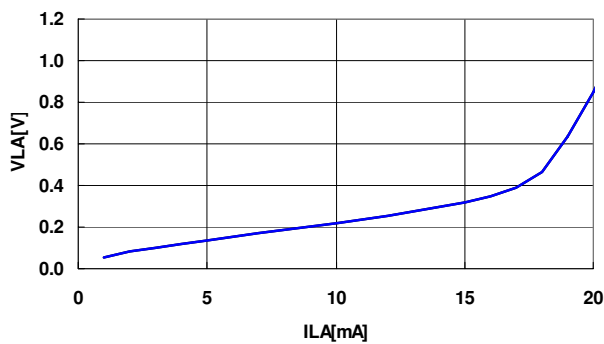

[CAUTION]

The specifications on this databook are only given for information, without any guarantee as regards either mistakes or omissions. The application circuits in this databook are described only to show representative usages of the product and not intended for the guarantee or permission of any right including the industrial rights.