

RF Modulator for VHF Band

DESCRIPTION

The NJM2519A is a RF modulator IC especially designed for VHF band RF modulator and consists of video clamp circuit, white clip circuit, video AM modulator and audio FM modulator, built into one chip.

PACKAGE OUTLINE



NJM2519AM

FEATURES

- Operating Voltage 5V
- VHF Oscillator on chip
- Regulator on chip
- Bipolar Technology
- Package Outline: DMP8

BLOCK DIAGRAM

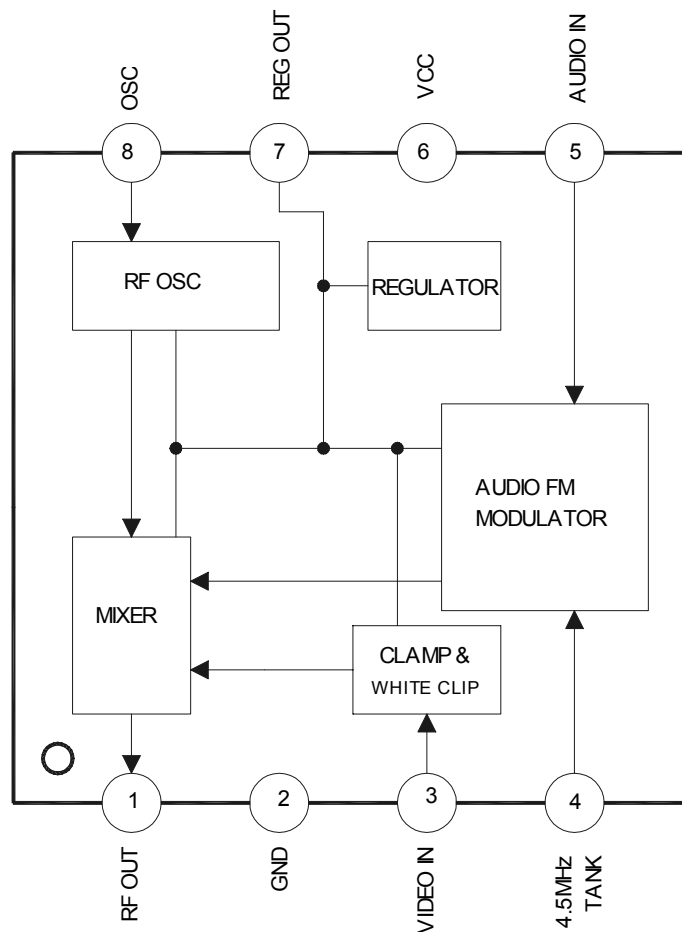

NJM2519A

■ ABSOLUTE MAXIMUM RATINGS

($T_A=25^{\circ}\text{C}$)

Parameter	Symbol	Ratings	Unit
Supply Voltage	V_{CC}	7	V
Power Dissipation	P_D	300	mW
Input Voltage	V_I	-0.3 to V_{CC}	V
Operating Temperature Range	T_{opr}	-20 to +75	$^{\circ}\text{C}$
Storage Temperature Range	T_{stg}	-40 to +125	$^{\circ}\text{C}$

■ RECOMMENDED OPERATING VOLTAGE RANGE

($T_A=25^{\circ}\text{C}$)

Parameter	Condition	Symbol	Min.	Typ.	Max.	Unit
Operating Voltage		V_{CC}	4.5	5.0	5.5	V

■ ELECTRICAL CHARACTERISTICS

($V_{CC}=5\text{V}, T_A=25^{\circ}\text{C}$)

Parameter	Condition	Symbol	Min.	Typ.	Max.	Unit
Operating Current	No video/audio input signal,	I_{CC}	11.5	15.3	19.1	mA
Video Output Level (Note 1)	Video input signal(Pin1)=0.5V _{PP}	V_O	(83)	86	(89)	dBu
Video Modulation Depth (Note 1)	Video input signal(Pin1)=0.5V _{PP}	mp	(70)	76	(82)	%
Video Limiter Modulation Depth (Note 1)	Video input signal(Pin1)=1.0V _{PP}	mpmax	(88)	94	(98)	%
Differential Gain	Video input signal(Pin1)=0.5V _{PP} Staircase	DG	-	± 3	-	%
Differential Phase	Video input signal(Pin1)=0.5V _{PP} Staircase	DP	-	± 3	-	deg
Picture-to-sound Ratio (Note 1)	Video input signal(Pin1)=0.5V _{PP}	PS	(13)	16	(19)	dB
Sound FM Modulation Sensitivity	Deviation of fs per 100mV	β_b	-	0.51	-	KHz/mV
Audio Distortion	Audio input signal(Pin7)=0.05V _{PP} 1kHz sine wave	THD	-	0.3	-	%
Audio Signal-to-noise Ratio	Sound Modulation 60% 1kHz sine wave	ASN	-	60	-	dB
Maximum Sound FM Modulation	Audio input signal(Pin7)=1.0V _{PP} 1kHz sine wave	mymax	-	700	-	%

(Note 1) Because AC characteristics largely depends on application circuit, these parameters are specified by the DC characteristics as shown in next page.

■ **DC ELECTRICAL CHARACTERISTICS** ($V_{CC}=5V, T_A=25^{\circ}C$, otherwise noted. All measurements performed in the DC test circuit are shown in next page)

Parameter	Condition (Note 2)	Symbol	Min.	Typ.	Max.	Unit
Video Output Signal Amplitude 1	$G_{v1}=G_{vh}-G_{vl}$	G_v	48	-	108	mV
Video Modulation Depth	$M_p=((G_v-M_w)/G_v)\times 100$ where $M_w=M_{wh}-M_{wl}$	M_p	66	-	78	%
Video Limiter Modulation Depth (Note 2)	$M_{pmax}=((G_v-W_c)/G_v)\times 100$ where $W_c=W_{ch}-W_{cl}$	M_{pmax}	85	94	98	%
Picture-to-sound Ratio	$P_s=20\log(G_v/(G_{va}/2))$	P_s	8	-	18	dB

(Note 2) Explanation of symbols

- V_v : VIDEO IN output voltage at Pin3
- V_{oso} : OSC output voltage at Pin8
- G_{vh} : RF OUT output voltage at Pin1
OSC(Pin8) input = $V_{oso}+0.3V$
- G_{vl} : RF OUT output voltage at Pin1
OSC(Pin8) input = $V_{oso}-0.3V$
- M_{wh} : RF OUT output voltage at Pin1
OSC (Pin 8) input = $V_{oso}+0.3V$, VIDEO IN(Pin3) input= $V_v + 0.41V$
- M_{wl} : RF OUT output voltage at Pin1
OSC (Pin 8) input = $V_{oso}-0.3V$, VIDEO IN(Pin3) input= $V_v + 0.41V$
- W_{ch} : RF OUT output voltage at Pin1
OSC (Pin 8) input = $V_{oso}+0.3V$, VIDEO IN(Pin3) input= $V_v + 0.75V$
- W_{cl} : RF OUT output voltage at Pin1
OSC (Pin 8) input = $V_{oso}-0.3V$, VIDEO IN(Pin3) input= $V_v + 0.75V$
- G_{va} : RF OUT output level at Pin1(4.5MHz Sine wave [peak to peak])
OSC(Pin8) input = $V_{oso}+0.6V$

NJM2519A

■ AC TEST CIRCUIT

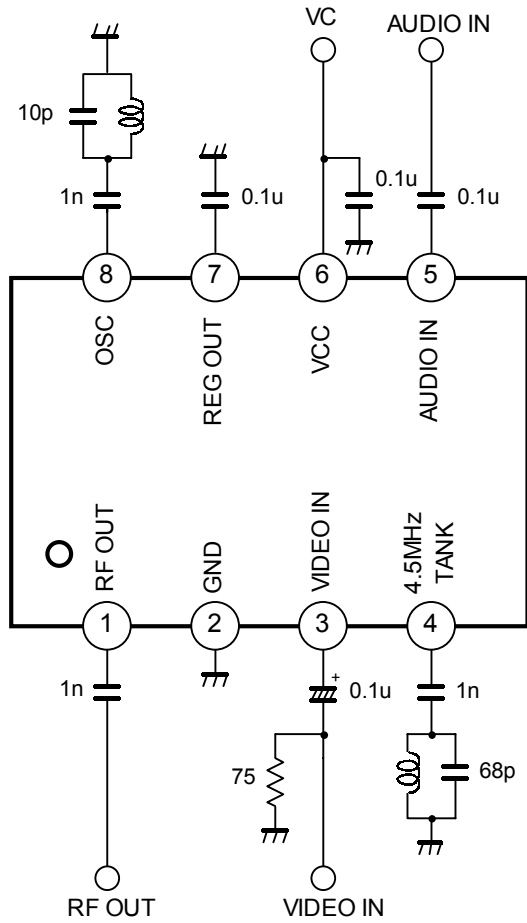

■ DC TEST CIRCUIT

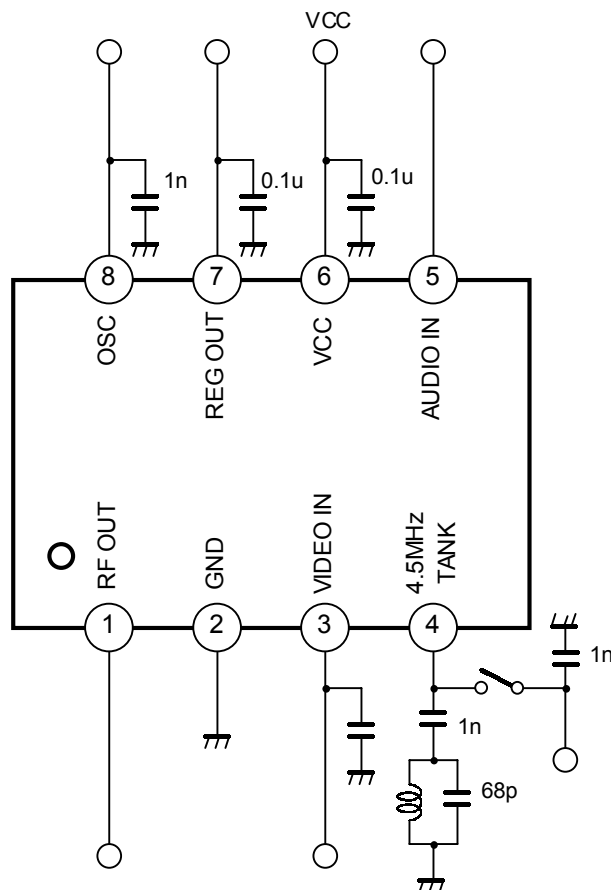

■ TERMINAL CHARACTERISTICS

No.	Symbol	Typ.DC Voltage (V)	Equivalent Circuit	Function
1	RF OUT	4		RF Signal Output
2	GND	-		GND
3	VIDEO IN	1.9		Video Signal Input
4	4.5MHz TANK	2.9		4.5MHz Tank Coil for Sound FM Modulation Circuit
5	AUDIO IN	0.035		Audio Signal Input
6	VCC	-		Power Supply

NJM2519A

No.	Symbol	Typ.DC Voltage (V)	Equivalent Circuit	Function
7	REG OUT	4		Regulator Output
8	OSC	2.2		RF Oscillator Pin

■ TYPICAL CHARACTERISTICS

$T_A=25^\circ\text{C}$

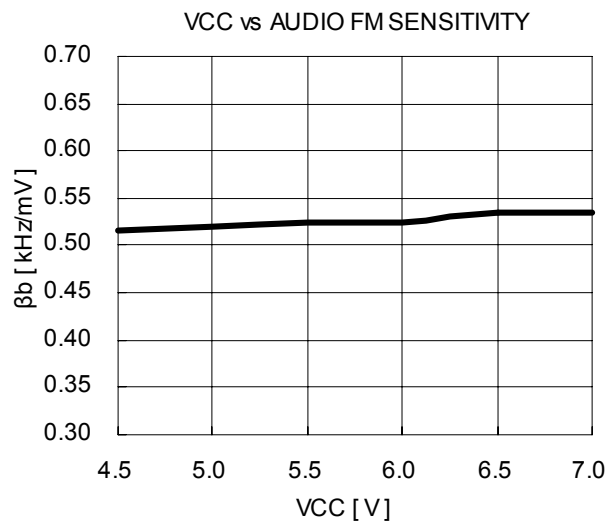
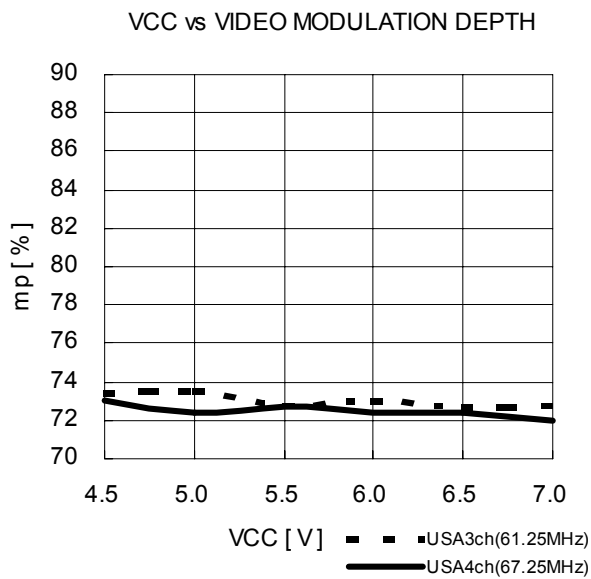
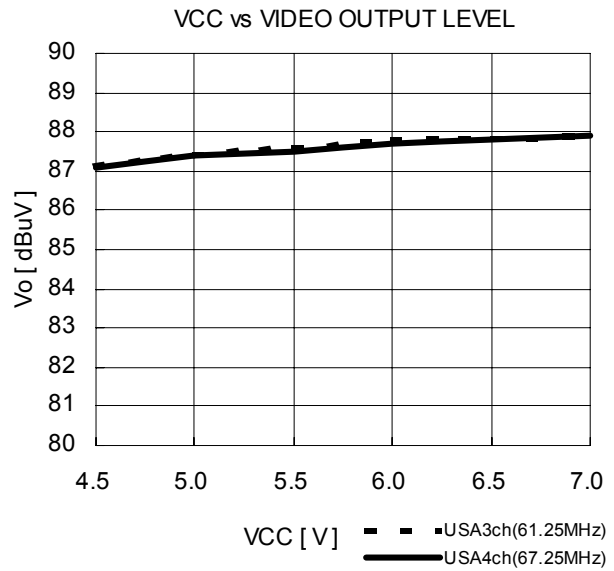
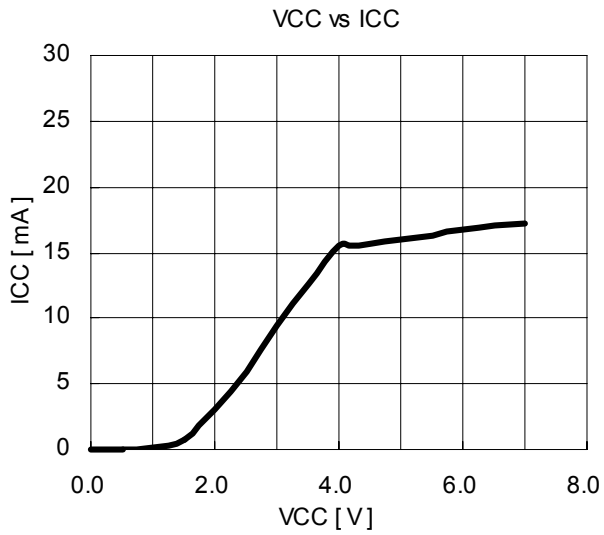

MEMO

[CAUTION]

The specifications on this databook are only given for information, without any guarantee as regards either mistakes or omissions. The application circuits in this databook are described only to show representative usages of the product and not intended for the guarantee or permission of any right including the industrial rights.