

300/400MHz Band 20mW Power Amplifier

■ GENERAL DESCRIPTION

The **NJM2278** is a narrow band, small signal amplifier, especially designed for use as the final RF amplifier in 300MHz / 400MHz band transmitter. The amplifier produces an output power of up to 20mW at the desired frequency, which frequency and power are adjusted by external input and output matching circuits. It also features excellent thermal stability of power gain.

■ PACKAGE OUTLINE

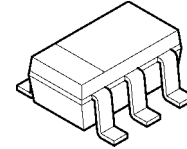

NJM2278F1

■ APPLICATIONS

300/400MHz Band Applications, 400MHz Industrial Radios, Digital Communication Systems

■ FEATURES (@400MHz, 2.7V)

- Low Operating Voltage 2V to 5.5V
- Low Operating Current 20 mA @ 0dBm input
- Power Gain 17dB @ -30dBm input 13dB @0dBm input
- Saturation Output 14dBm @3dBm input
- Variable Power Gain Control 4dB
- Excellent Power Gain Thermal Stability Gain Flatness ±1dB (-40°C to +85°C)
- RF IN Input Impedance 70 Ω
- RF OUT Output Impedance 110 Ω
- Recommended Operating Frequency 300MHz to 500MHz
- Bipolar Technology
- Package Outline SOT23-6 (MTP6) 2.8mm x 2.9mm

Note: For the signals at frequencies other than recommended operating frequency range of 300 to 500MHz, please refer to the "TYPICAL CHARACTERISTICS".

■ PIN CONFIGURATION

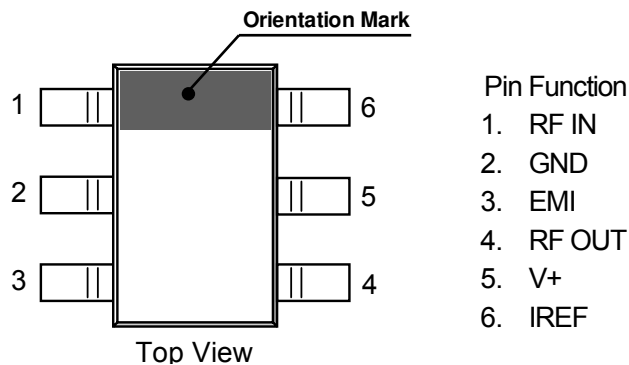

■ Function Block Diagram

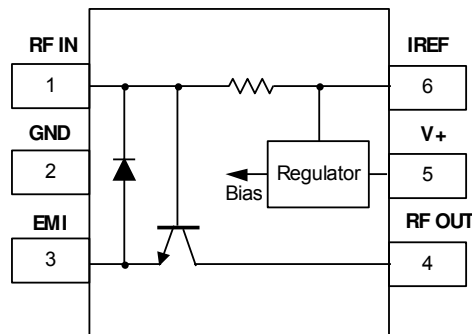

■ ABSOLUTE MAXIMUM RATINGS (Ta=25°C)

PARAMETER	SYMBOL	RATINGS	UNIT
Supply Voltage	V+	6.5	V
Power Dissipation	P _D	200	mW
RF Input Level	Pinmax	6	dBm
Operating Temperature	T _a	- 40 to + 85	°C
Storage Temperature	T _{stg}	- 40 to +125	°C

■ RECOMMENDED OPERATING CONDITIONS (Ta=25°C)

PARAMETER	SYMBOL	TEST CONDITIONS	MIN.	TYP.	MAX.	UNIT
Supply Voltage	V+		2.0	2.7	5.5	V

■ ELECTRICAL CHARACTERISTICS

(Ta=25°C, V⁺=2.7V, fin=400MHz, Pin=0dBm unless otherwise noted)

PARAMETER	SYMBOL	TEST CONDITIONS	MIN.	TYP.	MAX.	UNIT
Operating Current 1	I _{cc1}	No signal, Test circuit1	-	6	-	mA
Operating Current 2	I _{cc2}	Test circuit1	-	20	24	mA
Power Gain 1	PG1	Pin= - 30dBm, Test circuit1	-	17.5	-	dB
Power Gain 2	PG2	Pin= 0dBm, Test circuit1	-	13.5	-	dB
Saturation Output	PG _{sat}	Pin= 3dBm, Test circuit1	-	14.5	-	dBm
Noise Figure	NF	Test Circuit2	-	3	-	dB
Input Return Loss	IS11 ²	Test Circuit3	-	-13	-	dB
Output Return Loss	IS22 ²	Test Circuit3	-	-5	-	dB
RF OUT - RF IN Isolation	ISL	Test Circuit3	-	-27	-	dB
Power Input at 1dB Compression Point	P _{-1dB}	Test Circuit1	-	-9	-	dBm
Input Impedance	Z _{in}	Test Circuit3	-	70	-	Ω
Output Impedance	Z _{out}	Test Circuit3	-	110	-	Ω
Gain Flatness	PG _{freq}	fin =300 to 500MHz 400MHz standard Test Circuit3	-	-2.8	-	dB
Gain Control Rang	PG _{rang}	R _{ref} =0 to 100Ω Test Circuit4	-	-4.3	-	dB

■ REFERENCE (Thermal Characteristics)

PARAMETER	SYMBOL	TEST CONDITIONS	MIN.	TYP.	MAX.	UNIT
Gain Variation Over Temperature	PG _{temp}	T _a = - 40 to 85°C Test Circuit1	-1	0	+1	dB

■ TEST CIRCUIT

These test circuits allow the measurement of all parameters described in "ELECTRICAL CHARACTERISTICS".

- Test Circuit 1 for Icc1, Icc2, PG1, PG2, PGsat, P-1dB, PGtemp

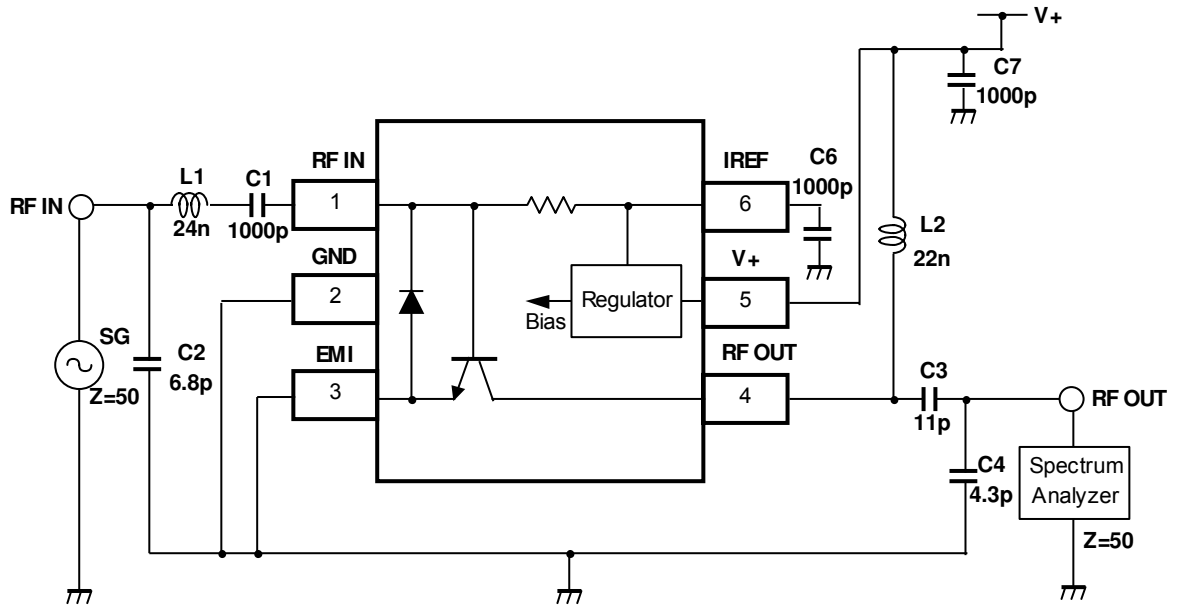

- Test Circuit 2 for NF

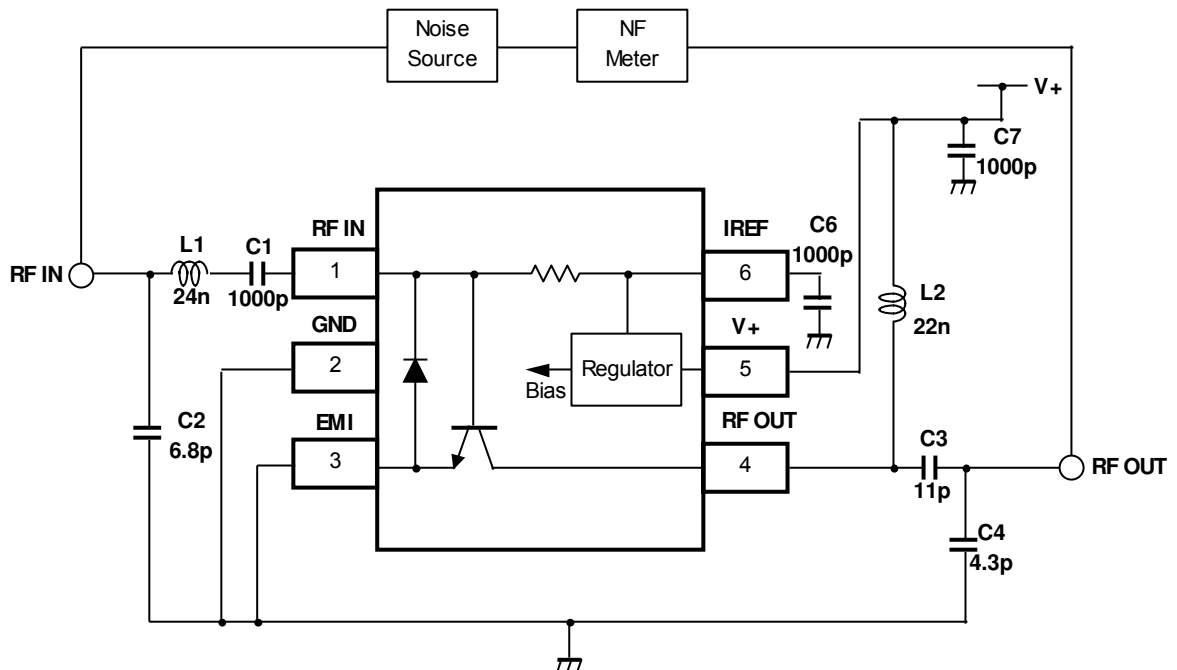

● Test Circuit 3 for IS11I², IS22I², ISL, Zin, Zout, PGfreq

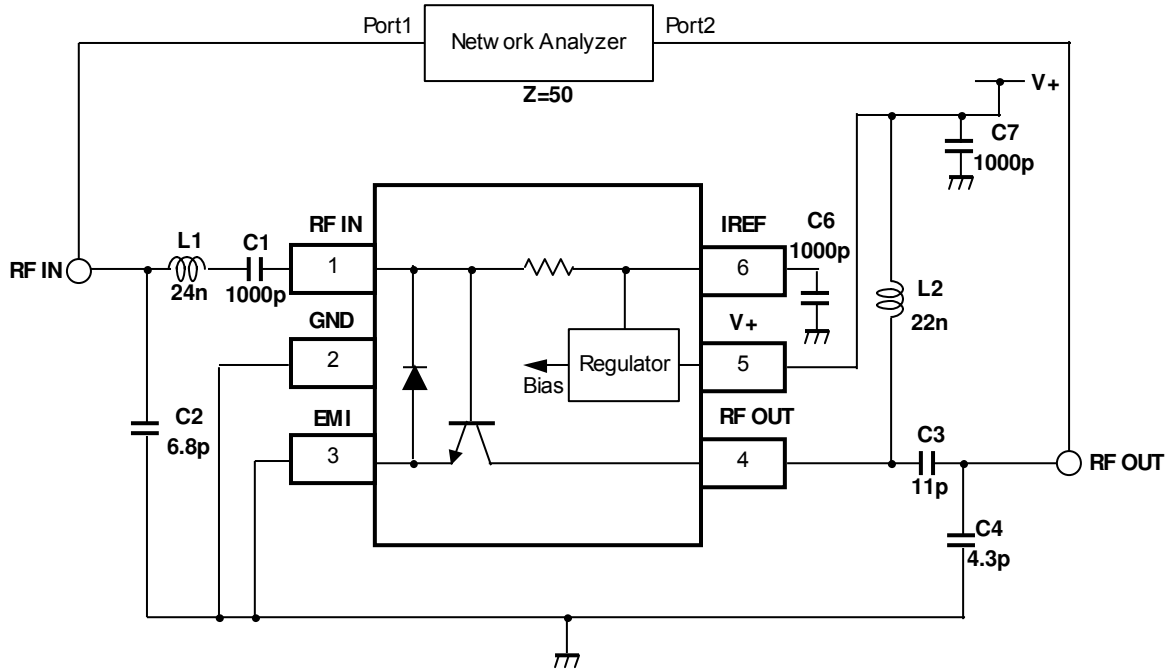

● Test Circuit 4 for PGang

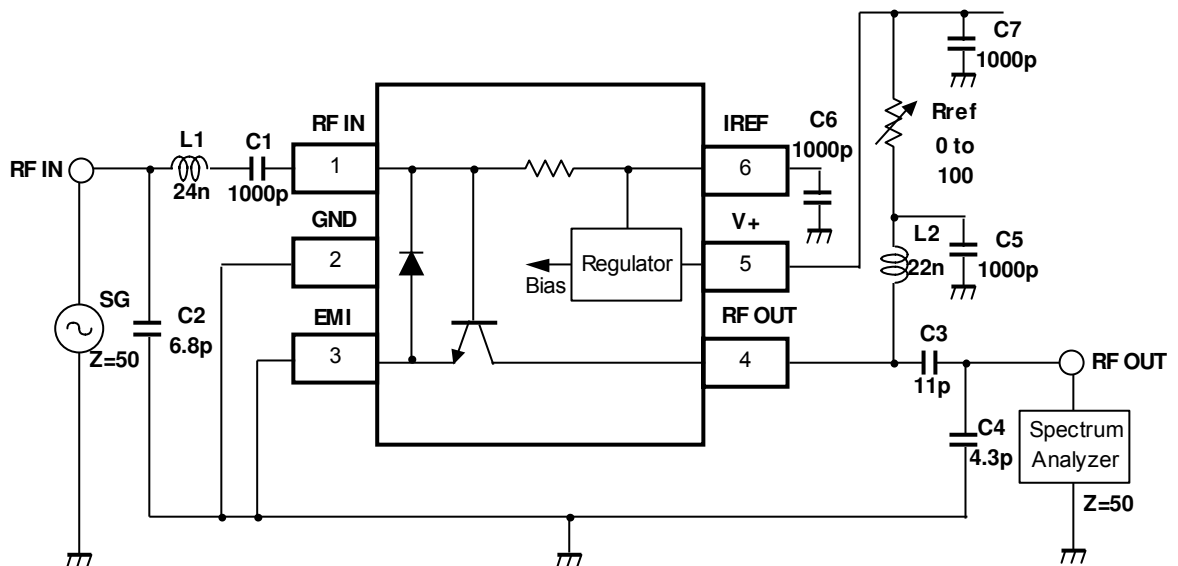

- Test Circuit 5 for S-Parameters (this item is not specified in "ELECTRICAL CHARACTERISTICS")

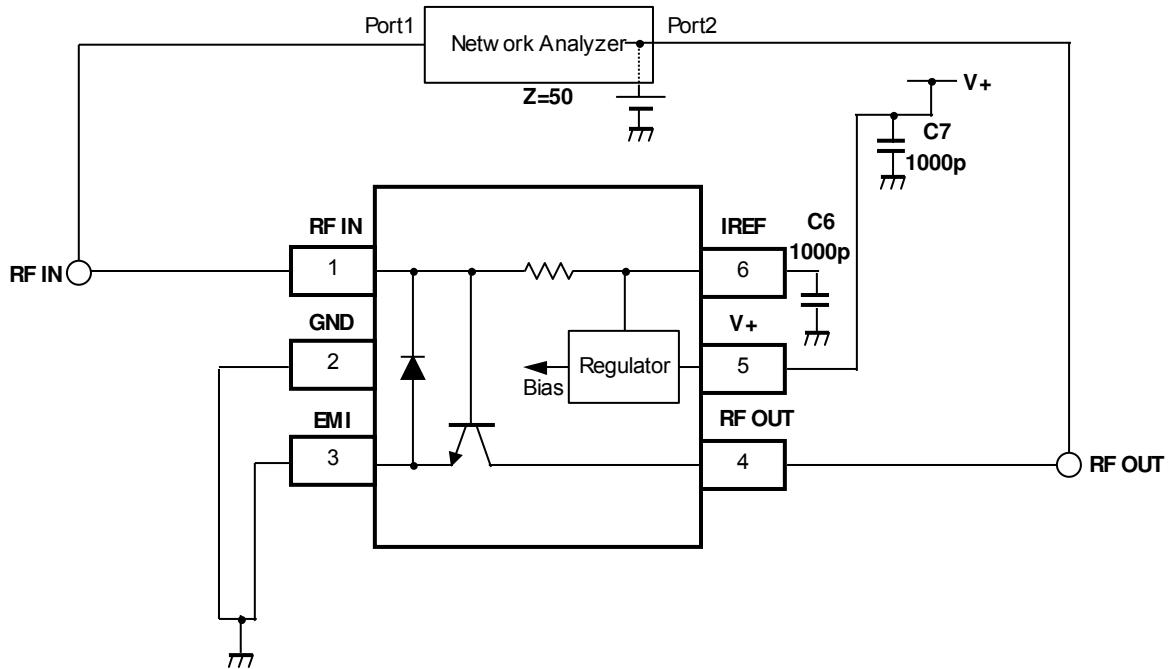

■ TERMINAL FUNCTION

Pin No.	SYMBOL	EQUIVALENT CIRCUIT	VOLTAGE	FUNCTION
1	RF IN		0.8V	RF Input The typical input impedance is 70Ω@400MHz.
2	GND		--	Ground For best performance, keep traces physically short and connect immediately to ground plane.
3	EMI		0V	Emitter In most applications, keep traces physically short and connect immediately to ground plane.
4	RF OUT		2.7V	RF Output This is an unmatched collector output of the final amplifier. The typical output impedance is 110Ω @400MHz. The external matching circuit is connected to present the optimum load impedance for maximum power and efficiency. An additional circuit of a bias inductor and series resistor provides DC bias. This resistor also serves to control the power gain by adjusting collector current.
5	V+		2.7V	Supply Voltage An external bypassing capacitance of 0.1μF is recommended.
6	IREF		0.8V	Reference of Current Source An external decoupling capacitor is placed between this pin and ground, and placed as close as possible to this pin.

Note:

- DC voltage of each pin is measured under the following condition
Ta=25°C, V⁺=2.7V, no RF signal input, test circuit1
- ESD protection diode exist between each of the following pins and V⁺
pin 1, 3, 6
- ESD protection diode exist between each of the following pins and ground
pin 1, 3, 4, 5, 6

■ EVALUATION PC BOARD

The evaluation board is useful for your design and to have more understanding of the usage and performance of this device. This evaluation board is designed to have the maximum value of PG at 400MHz, and its circuit is the same as Test Circuit 4 ($V+=2.7V$).

Note that this board is not prepared to show the recommendation of pattern and parts layout.

● Circuit Diagram

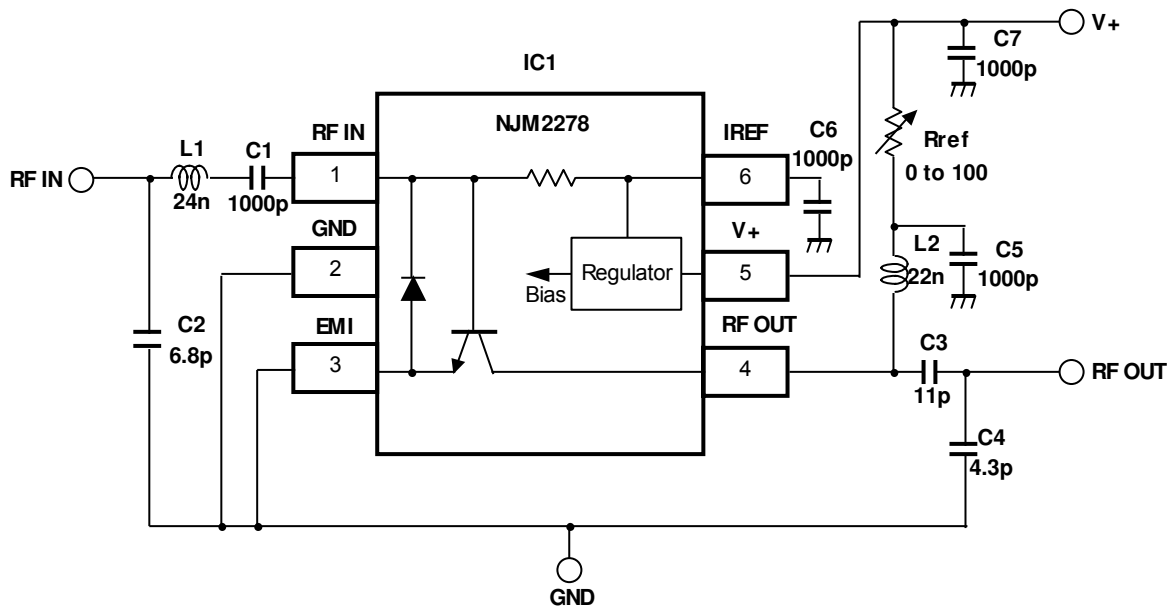

● List of Component

Items	Designation	Value	Supplier	Note
IC	IC1	NJM2278	New Japan Radio	
Inductor	L1	24nH	Murata	LQW18A series
	L2	22nH	Murata	LQW18A series
Capacitor	C1	1000pF	Taiyo Yuden	GRM21 series
	C2	6.8pF	Taiyo Yuden	UCN033 series
	C3	11pF	Taiyo Yuden	UCN033 series
	C4	4.3pF	Taiyo Yuden	UCN033 series
	C5	1000pF	Taiyo Yuden	GRM21 series
	C6	1000pF	Taiyo Yuden	GRM21 series
	C7	1000pF	Taiyo Yuden	GRM21 series
Potentiometer	Rref	100Ω	Murata	PVG3A101C01

- PC Board

Circuit Side View

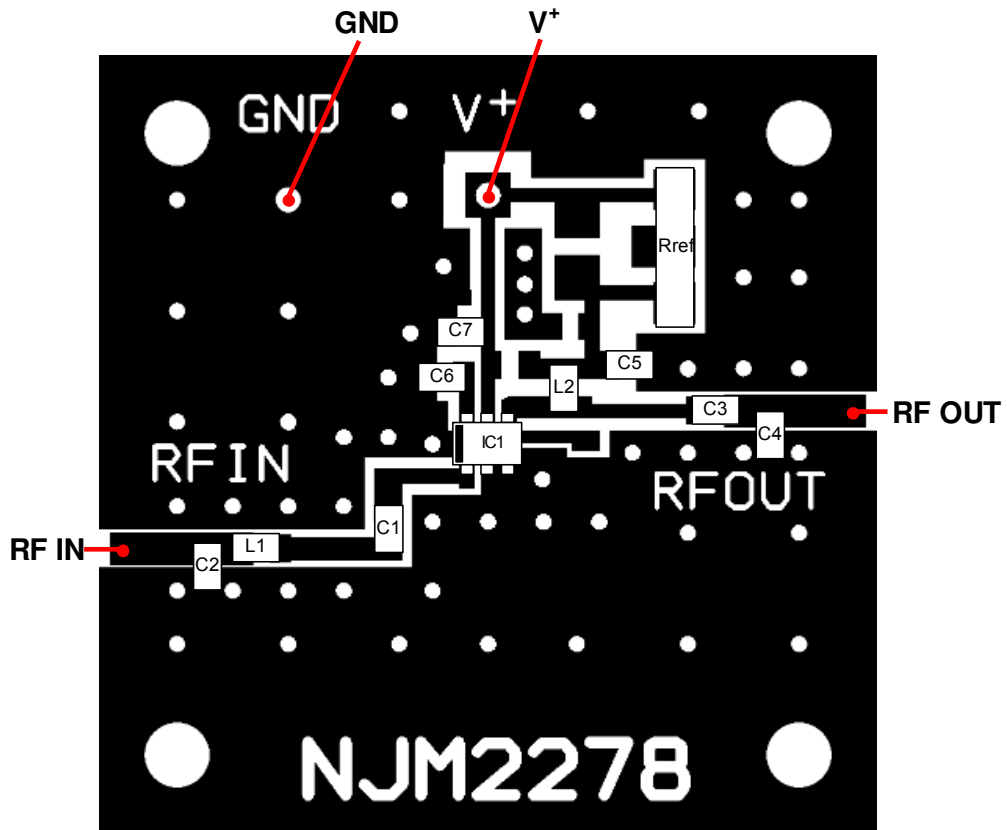

Ground Side View

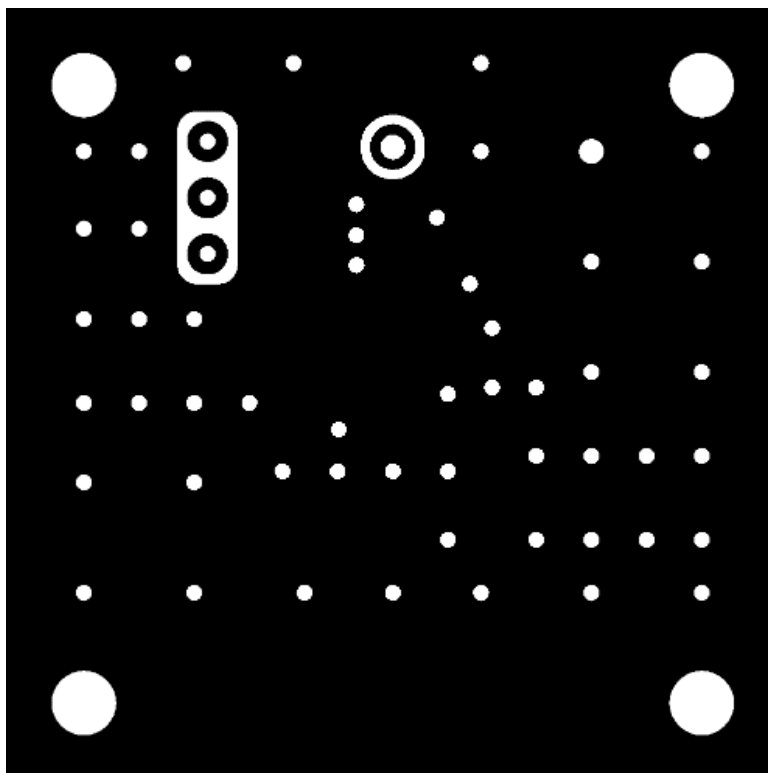

■ TYPICAL CHARACTERISTICS (Ta=25°C, V+=2.7V, unless otherwise noted)

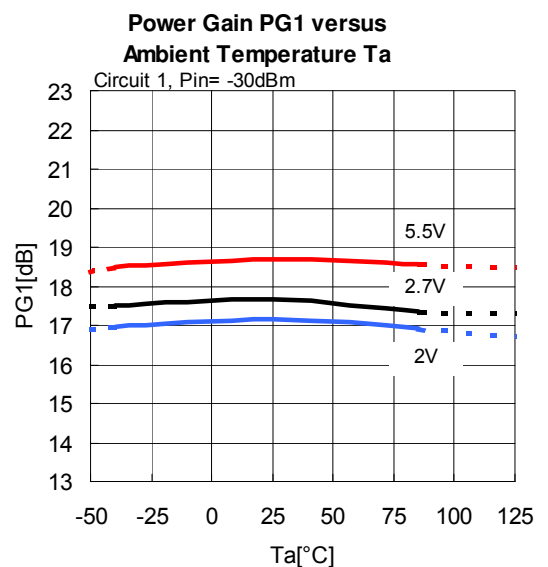
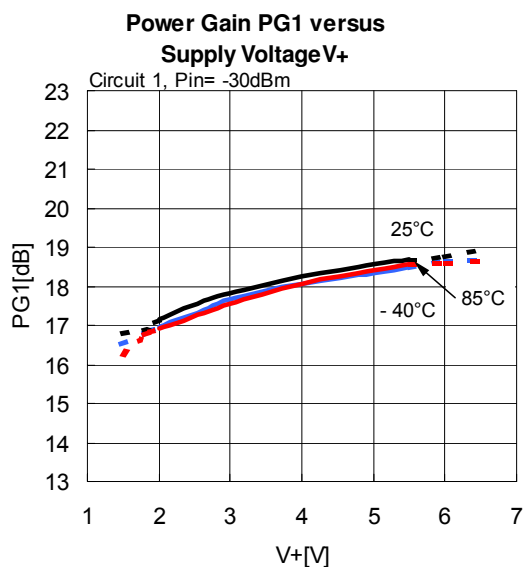
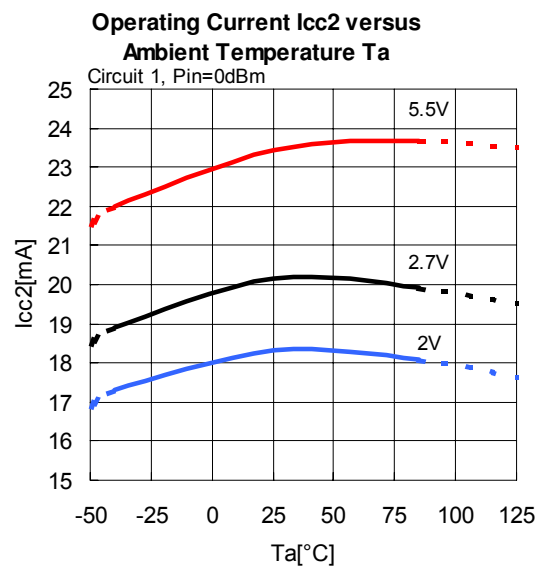
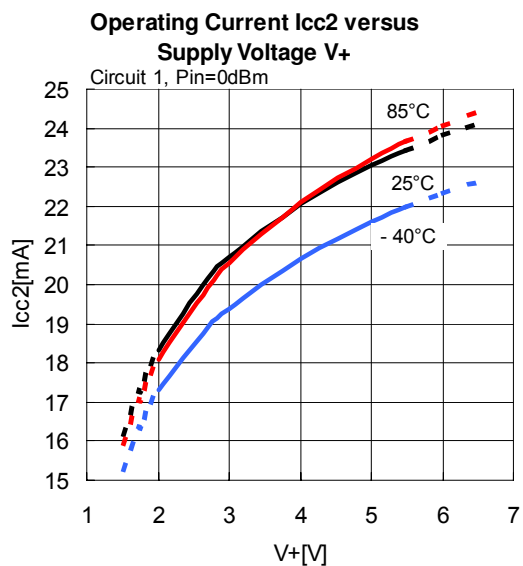
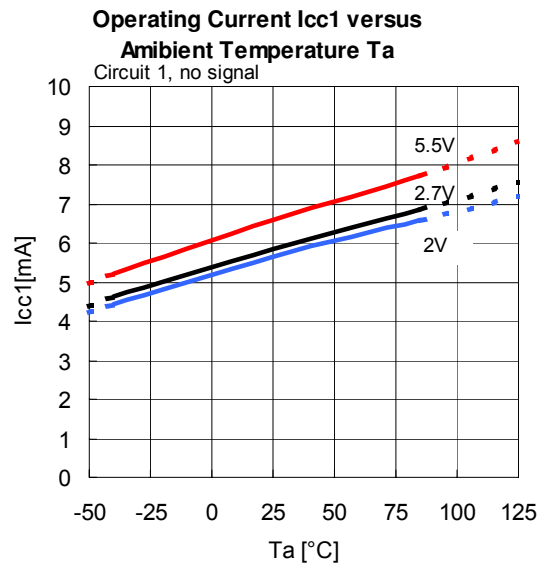
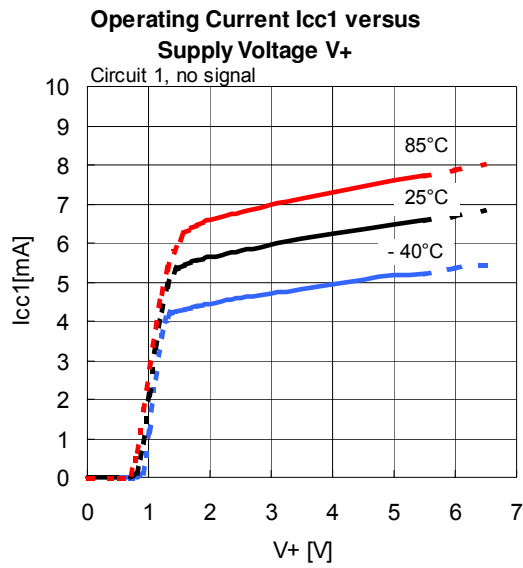

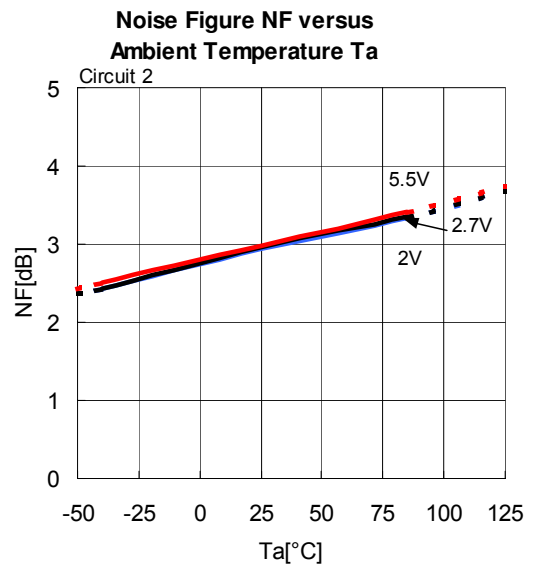
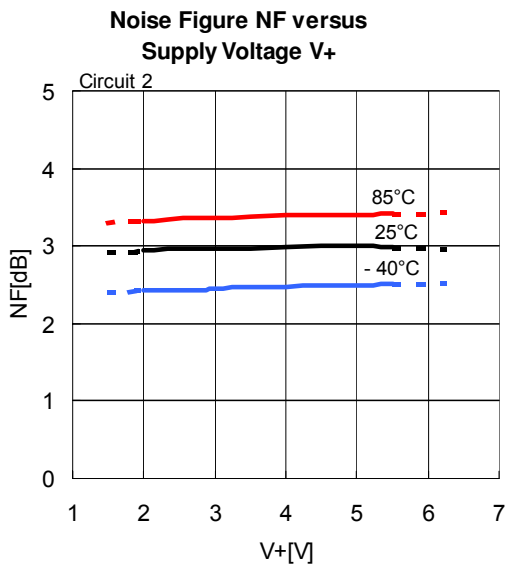
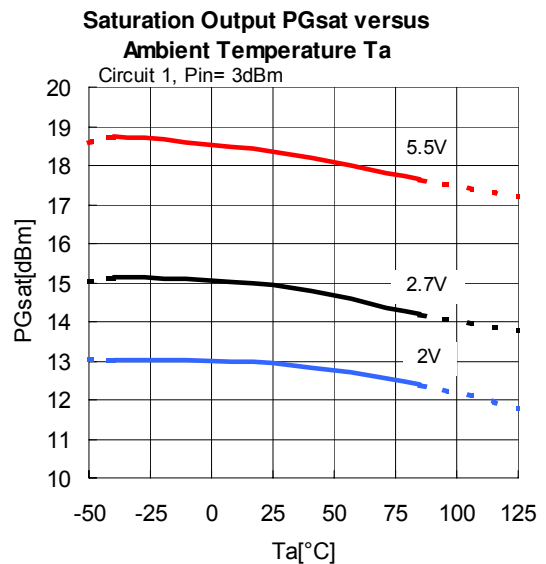
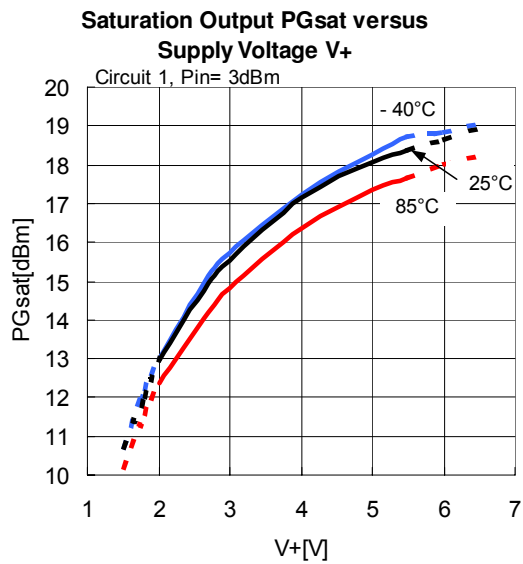
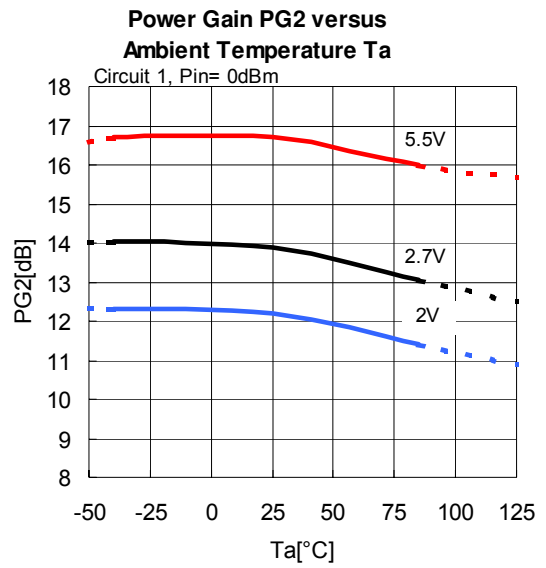
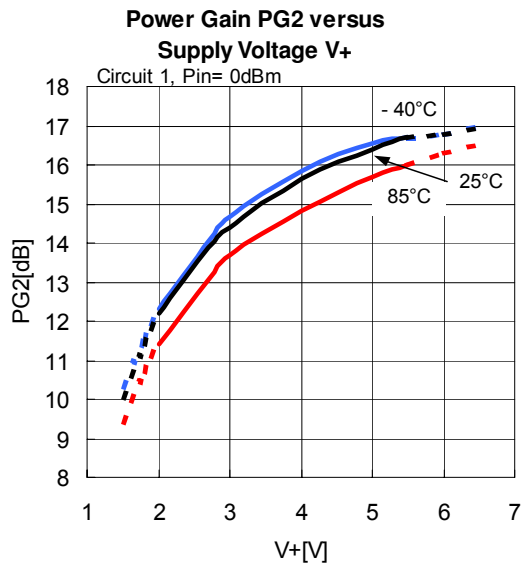

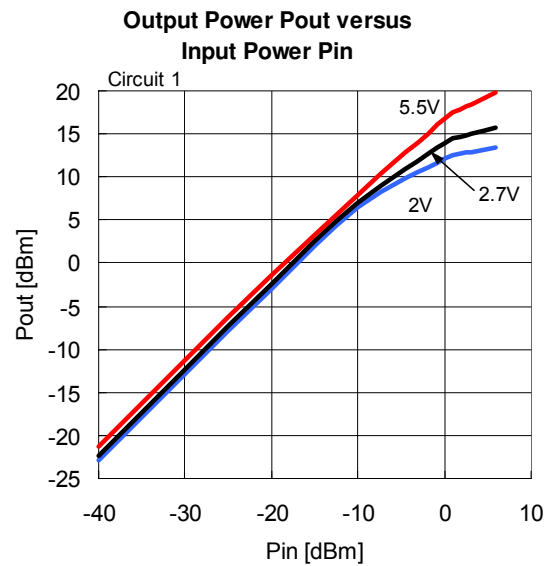
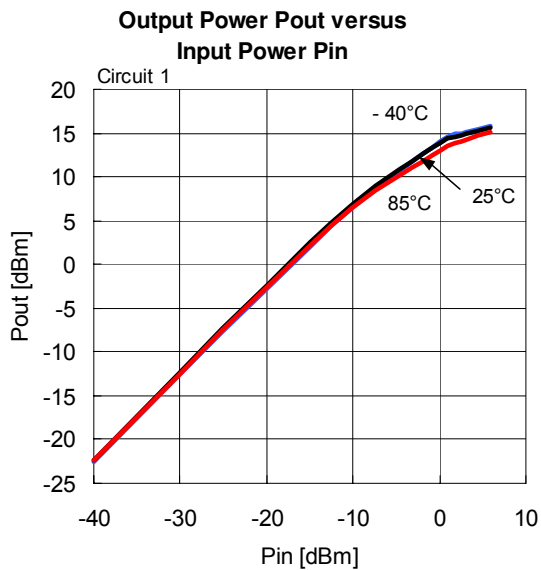
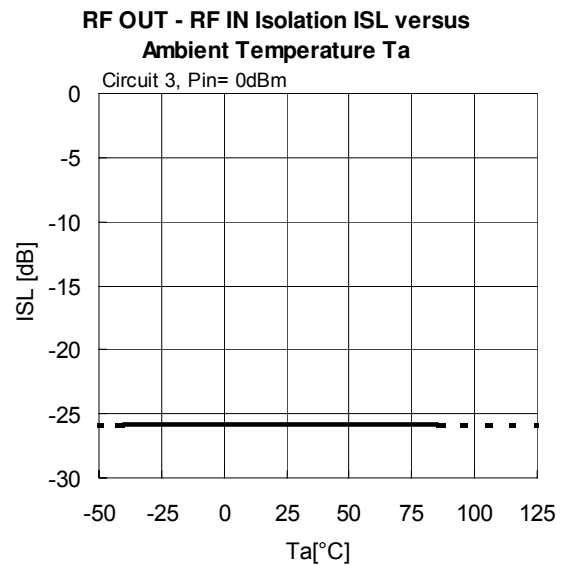
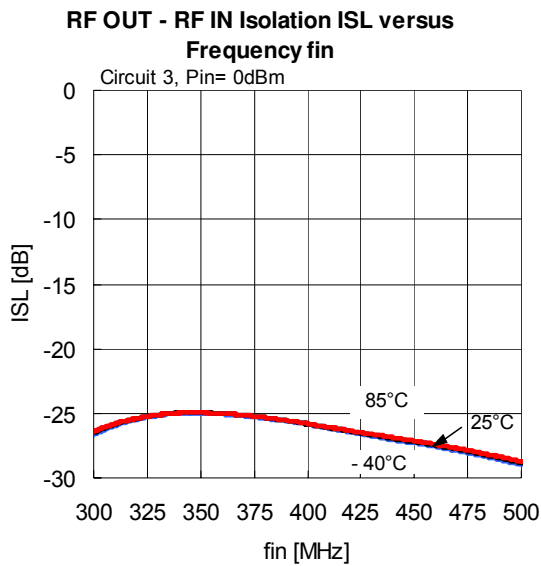
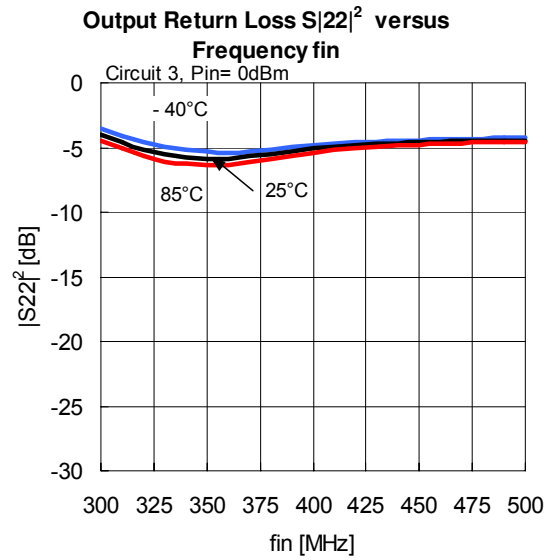
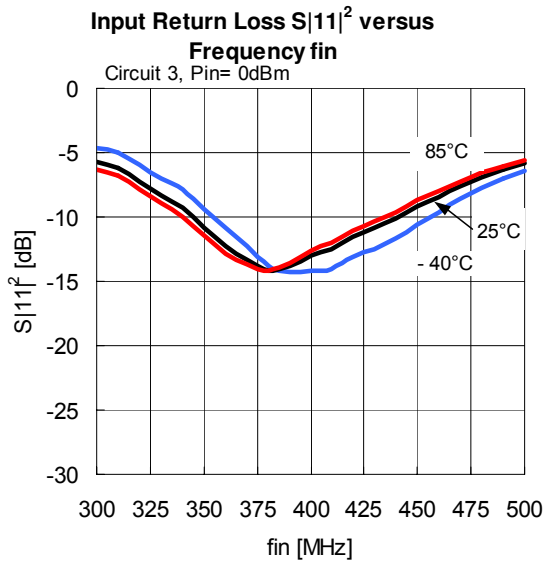

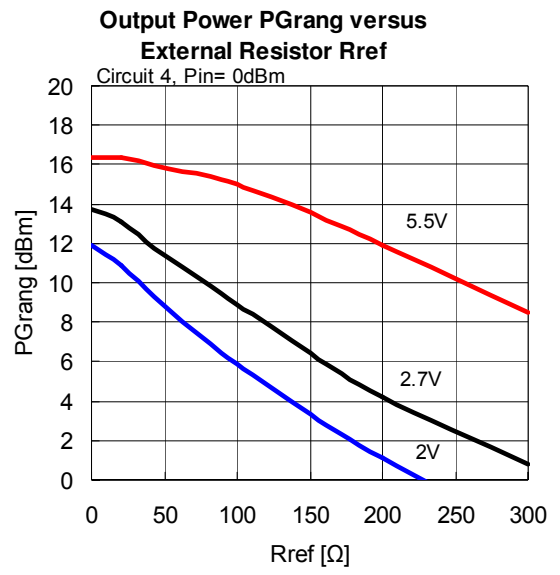
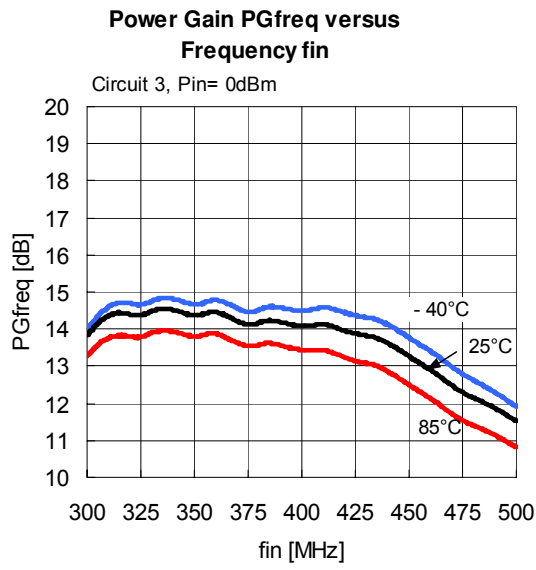

■ Impedance (reference) (Ta=25°C, V+=2.7V)

RF IN Input Impedance Zin(Circuit 3, Pin=0dBm)

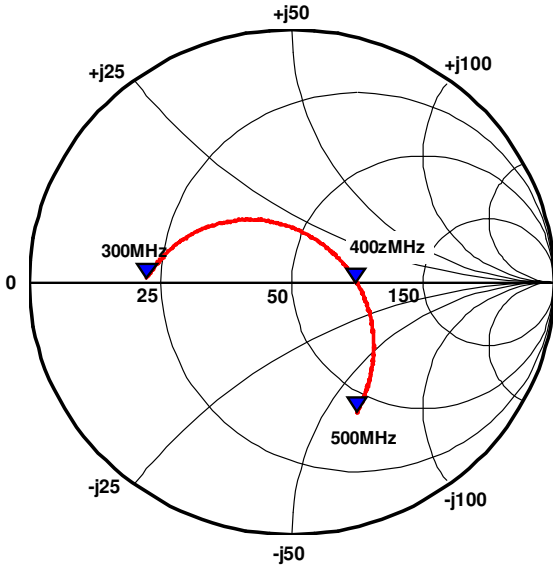

RF OUT Output Impedance Zout(Circuit 3, Pin=0dBm)

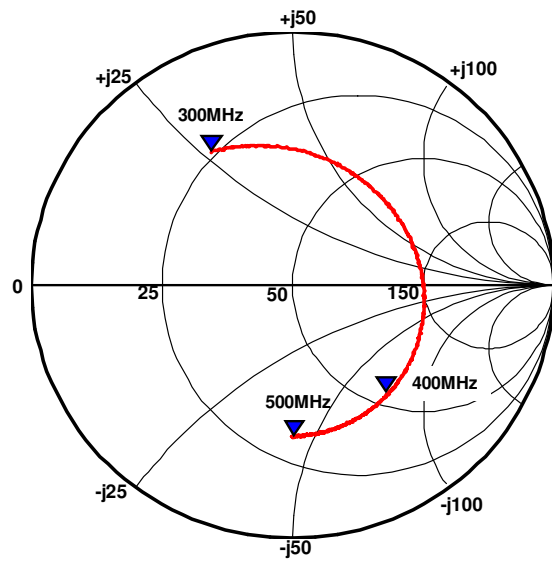

S11(Circuit 5, Pin= -10dBm)

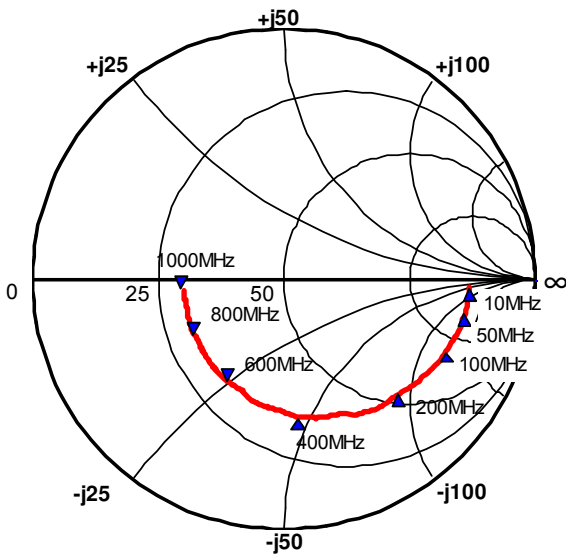

S22(Circuit 5, Pin= -10dBm)

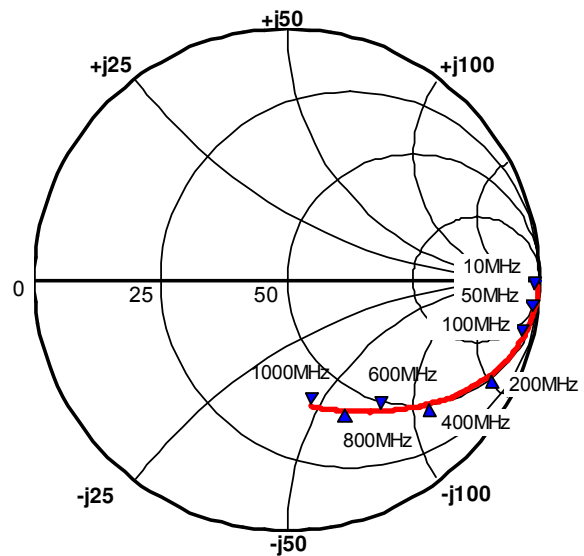

[CAUTION]
 The specifications on this databook are only given for information, without any guarantee as regards either mistakes or omissions. The application circuits in this databook are described only to show representative usages of the product and not intended for the guarantee or permission of any right including the industrial rights.