

1.8V Operate PWM control Step-Up / Flyback switching regulator IC

■ GENERAL DESCRIPTION

The **NJU7677** is a high-speed switching regulator control IC for PWM control step-up and fly-back converter that operates from 1.8V. It incorporates a totem pole driver output, which can directly drive an external MOS-FET. The NJU7677 also has a soft-start function, dead time control and timer latch for short circuit protection and their times are all adjustable with external parts. It is available in a small and thin 8-lead MSOP (TVSP) package. It is suitable for battery powered applications.

■ PACKAGE OUTLINE

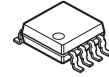

NJU7677RB1
(MSOP8 (TVSP8))

■ FEATURES

- PWM switching control
- Operating Voltage 1.8V to 7V
- Wide Oscillator Range 300kHz to 1MHz
- Maximum Duty Cycle 90% typ.
- Quiescent Current 600 μ A typ.
- Soft-Start Function Internal : 4ms typ. or adjustable
- Dead Time Control
- Timer Latch for Short Circuit Protection
- C-MOS Technology
- Package Outline NJU7677RB1 : MSOP8 (TVSP8)*

*MEET JEDEC MO-187-DA / THIN TYPE

■ PIN CONFIGURATION

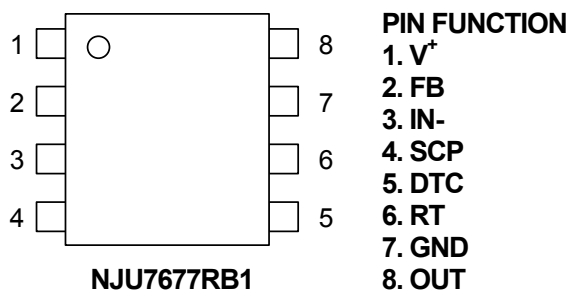

NJU7677

■ BLOCK DIAGRAM

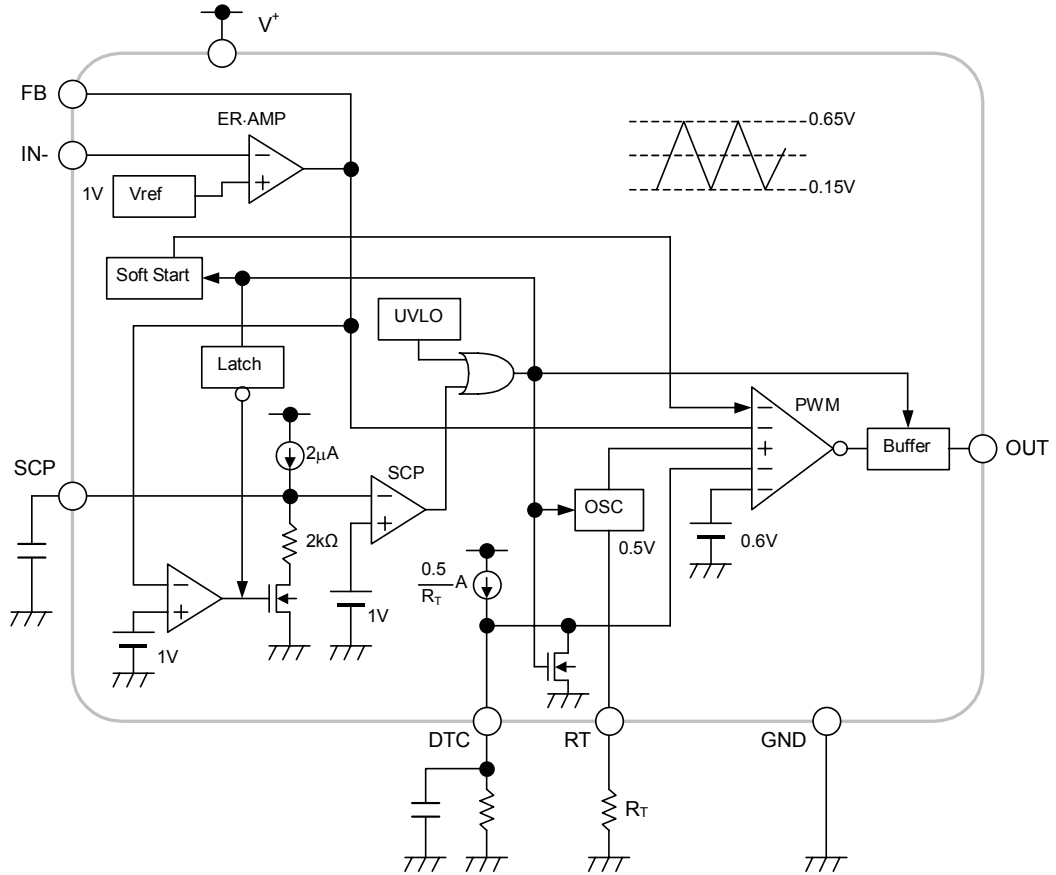

■ ABSOLUTE MAXIMUM RATINGS

(Ta=25°C)

PARAMETER	SYMBOL	MAXIMUM RATINGS	UNIT
Supply Voltage	V ⁺	+8	V
Output Pin Current	I _O	±50	mA
Power Dissipation	P _D	320	mW
Operating Temperature Range	T _{OPR}	-40 to +85	°C
Storage Temperature Range	T _{STG}	-40 to +125	°C

■ RECOMMENDED OPERATING CONDITIONS

(Ta=25°C)

PARAMETER	SYMBOL	MIN.	TYP.	MAX.	UNIT
Operating Voltage	V ⁺	1.8	–	7	V
Oscillator Timing Resistor	R _T	30	47	120	kΩ
Oscillation Frequency	f _{OSC}	300	700	1,000	kHz

■ ELECTRICAL CHARACTERISTICS

(V⁺=3.3V, R_T=47kΩ, Ta=25°C)

PARAMETER	SYMBOL	TEST CONDITION	MIN.	TYP.	MAX.	UNIT
Under Voltage Lockout Block						
ON Threshold Voltage	V _{T_ON}	V ⁺ = L → H	1.6	1.7	1.8	V
OFF Threshold Voltage	V _{T_OFF}	V ⁺ = H → L	1.5	1.6	1.7	V
Hysteresis Voltage	V _{HYS}		60	100	–	mV
Soft Start Block						
Soft Start Time	T _{SS}	V _{T_ON} → Duty=80%	2	4	8	ms
Short Circuit Protection Block						
Input Threshold Voltage	V _{T_PC}	FB Pin	0.95	1.00	1.05	V
Charge Current	I _{CHG}	V _{SCP} =0V	1.5	2	2.5	μA
Latch Mode ON Threshold Voltage	V _{T_LA}	SCP Pin	0.90	1.00	1.10	V
Latch Mode OFF Threshold Voltage	V _{T_LAOFF}	SCP Pin	0.35	0.6	0.85	V
Oscillator Block						
RT Pin Voltage	V _{RT}		-8%	0.5	+8%	V
Oscillation Frequency	f _{OSC}		630	700	770	kHz
Oscillate Supply Voltage Fluctuations	f _{DV}	V ⁺ =1.8V to 7V	–	1	–	%
Oscillate Temperature Fluctuations	f _{DT}	Ta=-40°C to +85°C	–	3	–	%

NJU7677

■ ELECTRICAL CHARACTERISTICS

($V^+=3.3V$, $R_T=47k\Omega$, $T_a=25^\circ C$)

PARAMETER	SYMBOL	TEST CONDITION	MIN.	TYP.	MAX.	UNIT
Error Amplifier Block						
Reference Voltage	V_B		-1.0%	1.00	+1.0%	V
Input Bias Current	I_B		-0.1	–	0.1	μA
Open Loop Gain	A_V		–	80	–	dB
Gain Bandwidth Product	G_B		–	1	–	MHz
Output Source Current	I_{OM+}	$V_{FB}=1V$, $V_{IN-}=0.9V$	20	35	50	μA
Output Sink Current	I_{OM-}	$V_{FB}=1V$, $V_{IN-}=1.1V$	1.0	4.0	12	mA
PWM Compare Block						
Input Threshold Voltage	$V_{T,0}$	Duty=0%	0.10	0.16	0.22	V
	$V_{T,50}$	Duty=50%	0.36	0.42	0.48	V
Maximum Duty Cycle	$M_{AX}D_{UTY,1}$	$V_{FB}=0.9V$	85	90	95	%
	$M_{AX}D_{UTY,2}$	$V_{FB}=0.9V$, $R_{DTC}=43k\Omega$	45	55	65	%
Output Block						
Output High Level ON Resistance	R_{OH}	$I_O=-20mA$	–	6	12	Ω
	$R_{OH,1.8}$	$I_O=-20mA$, $V^+=1.8V$	–	10	20	Ω
Output Low Level ON Resistance	R_{OL}	$I_O=+20mA$	–	4.5	9	Ω
	$R_{OL,1.8}$	$I_O=+20mA$, $V^+=1.8V$	–	8	16	Ω
General Characteristics						
Quiescent Current	I_{DD}	$R_L=Non\ Load$	–	600	900	μA

■ TYPICAL APPLICATIONS

Step-Up Converter

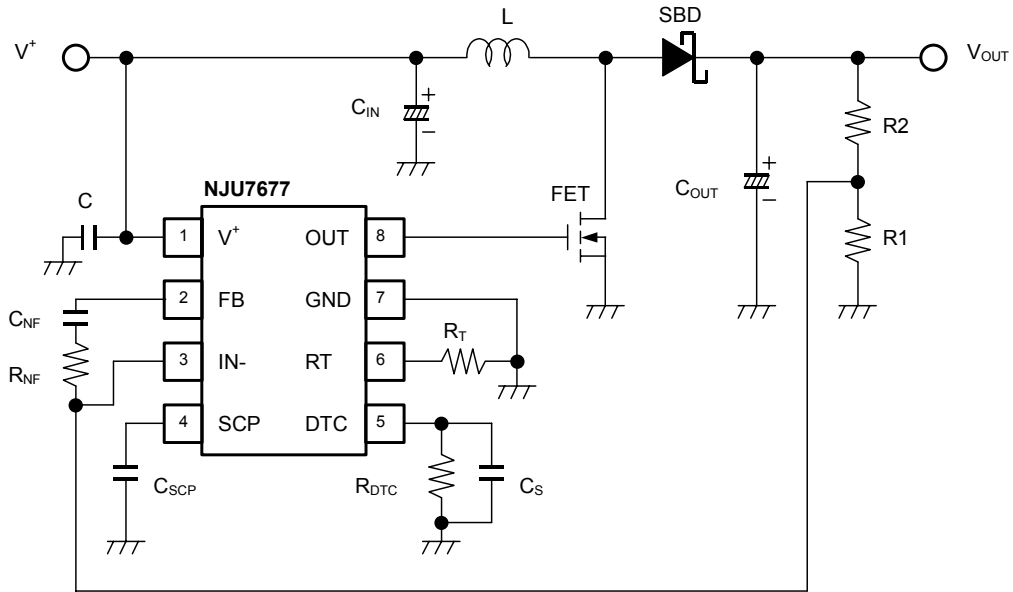

Flyback Converter

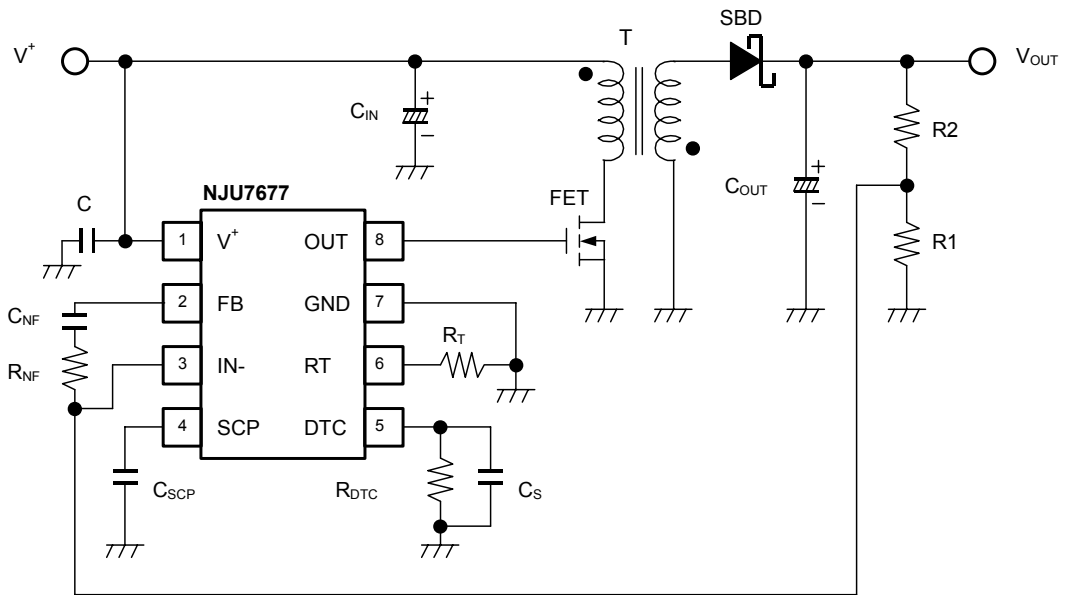

■ TYPICAL CHARACTERISTICS

Oscillation Frequency vs. Timing Resistance
($V^+ = 3.3V, T_a = 25^\circ C$)

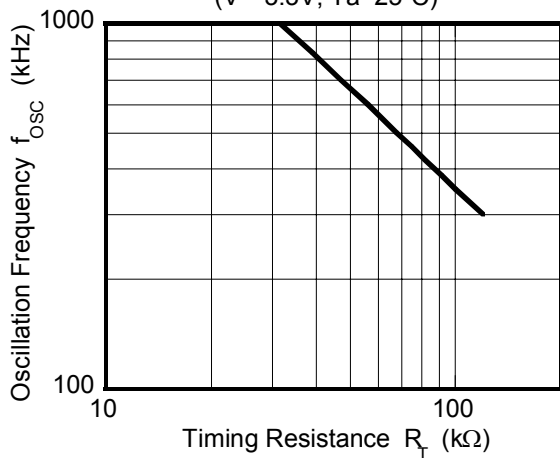

Maximum Duty Cycle vs. Oscillator Frequency
($V^+ = 3.3V, T_a = 25^\circ C$)

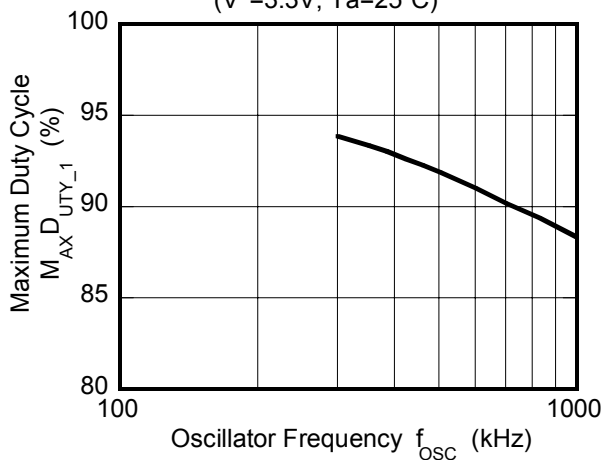

Oscillation Frequency vs. Operating Voltage
($R_T = 47k\Omega, T_a = 25^\circ C$)

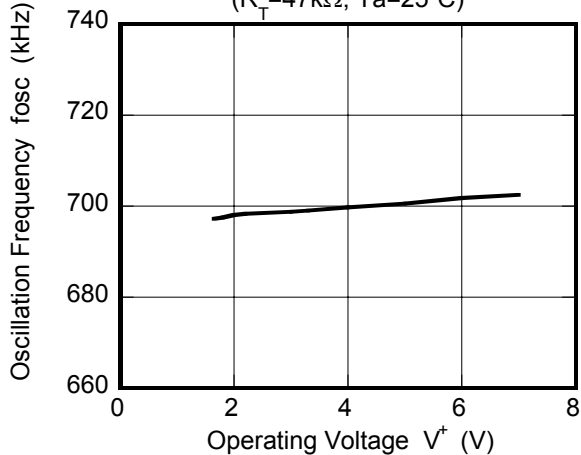

Duty Cycle vs. R_{DTC}

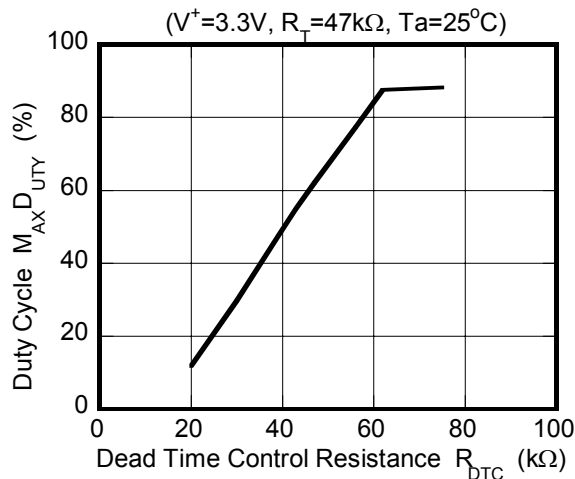

Reference Voltage vs. Operating Voltage
($T_a = 25^\circ C$)

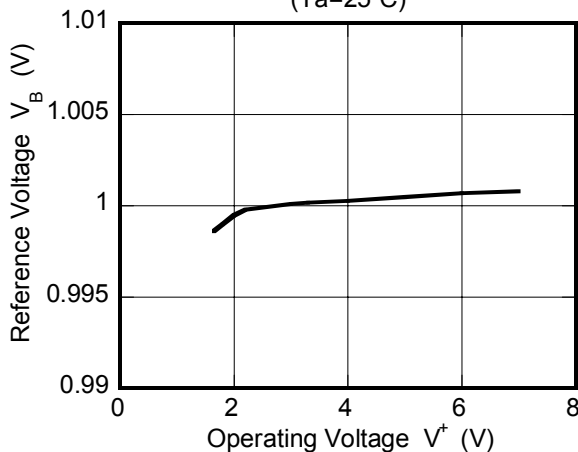

Quiescent Current vs. Operating Voltage
($R_T = 47k\Omega, R_L = \text{Non Load}, T_a = 25^\circ C$)

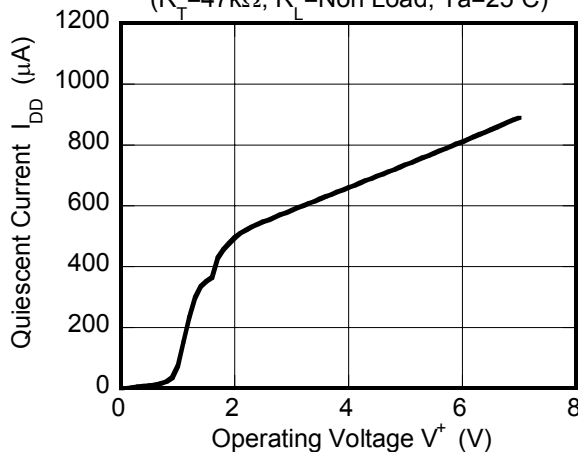

■ TYPICAL CHARACTERISTICS

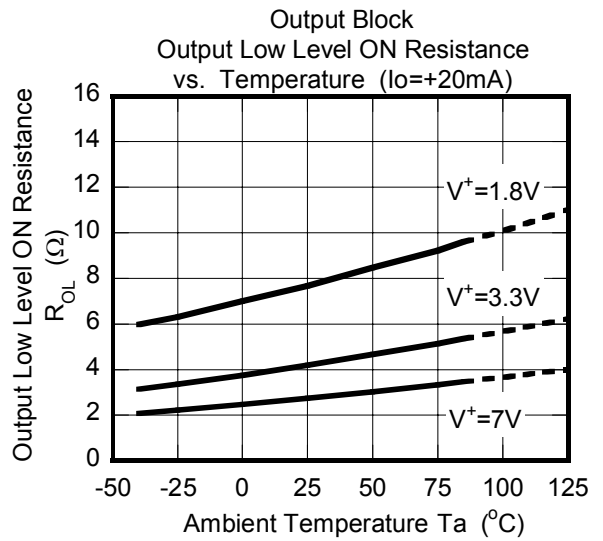
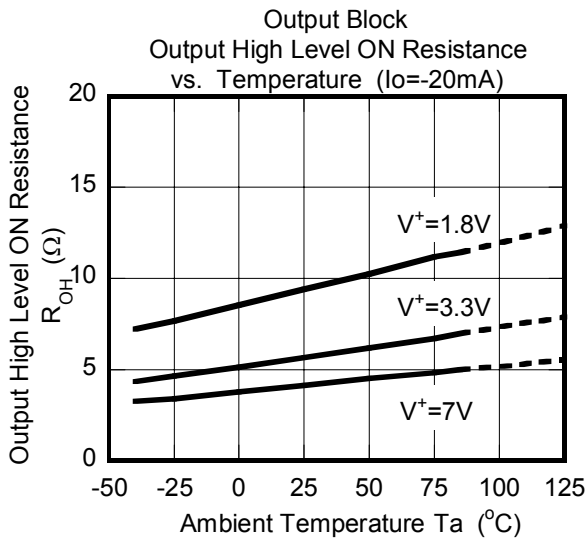
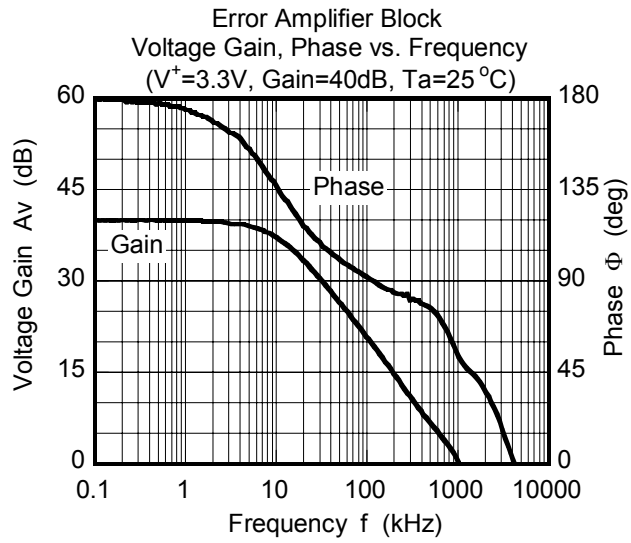

■ TYPICAL CHARACTERISTICS

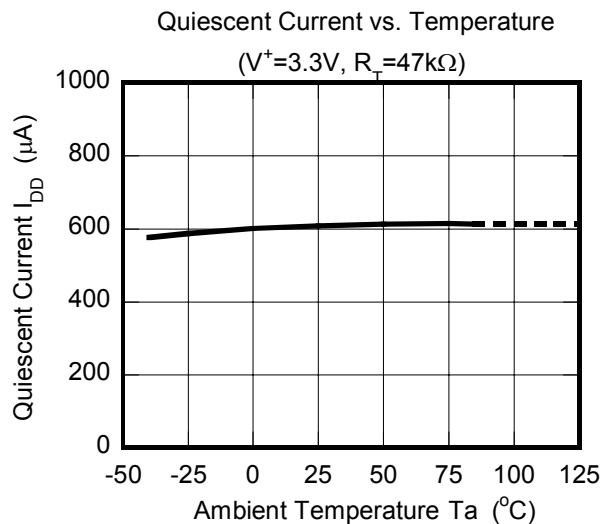
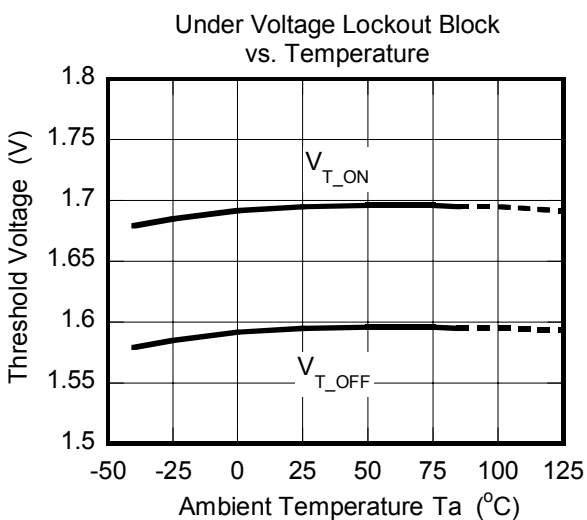
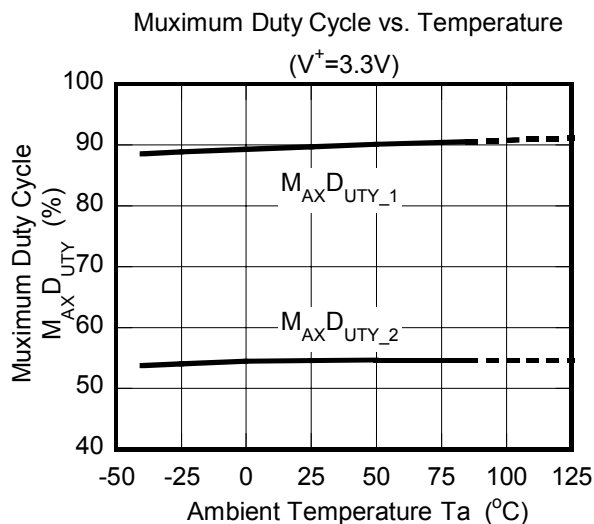
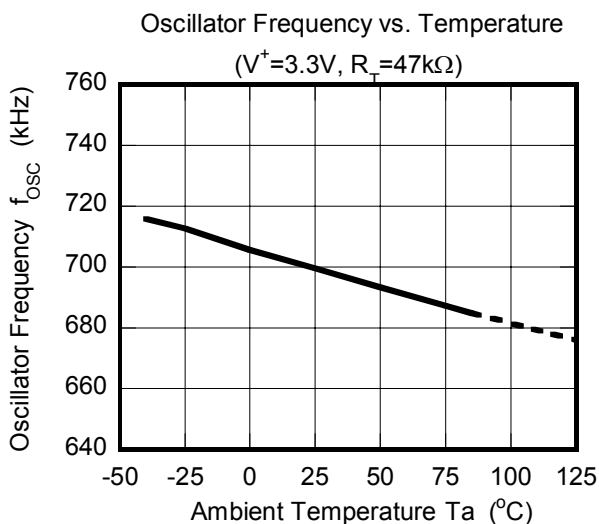
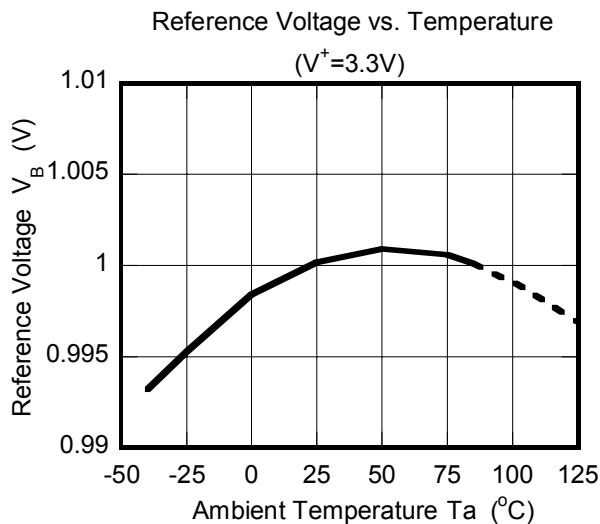
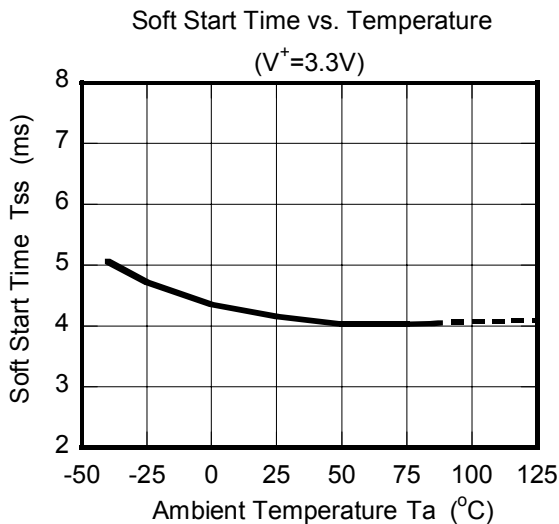

MEMO

[CAUTION]

The specifications on this databook are only given for information, without any guarantee as regards either mistakes or omissions. The application circuits in this databook are described only to show representative usages of the product and not intended for the guarantee or permission of any right including the industrial rights.