

Low Dropout Voltage Regulator with Reset

■ GENERAL DISCRIPTION

The NJU7271 is a low drop out voltage regulator with output-monitor reset function. Advanced CMOS technology achieves ultra low current consumption and high accuracy.

It delivers up to 5V/100mA output power with the maximum input voltage of 9V.

The NJU7270 is suitable for MPU applications.

■ PACKAGE OUTLINE

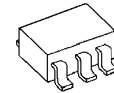

NJU7271F

■ FEATURES

- Ultra Low Quiescent Current $I_q = 3.0\mu\text{A typ. } (I_o = 0\text{mA})$
- Output Voltage Accuracy $V_o = \pm 1.0\%$
- Reset Voltage Accuracy $V_{RT} = \pm 1.0\%$
- Output Voltage Monitor type
- Output Current $I_o(\text{max.}) = 100\text{mA}$
- Output capacitor with 0.1 μF ceramic capacitor
- Nch Open Drain Output
- Internal Short Circuit Current Limit
- CMOS Technology
- Package Outline SOT-23-5

■ PIN CONFIGURATION

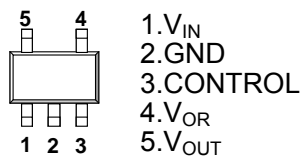

NJU7271F

■ EQUIVALENT CIRCUIT

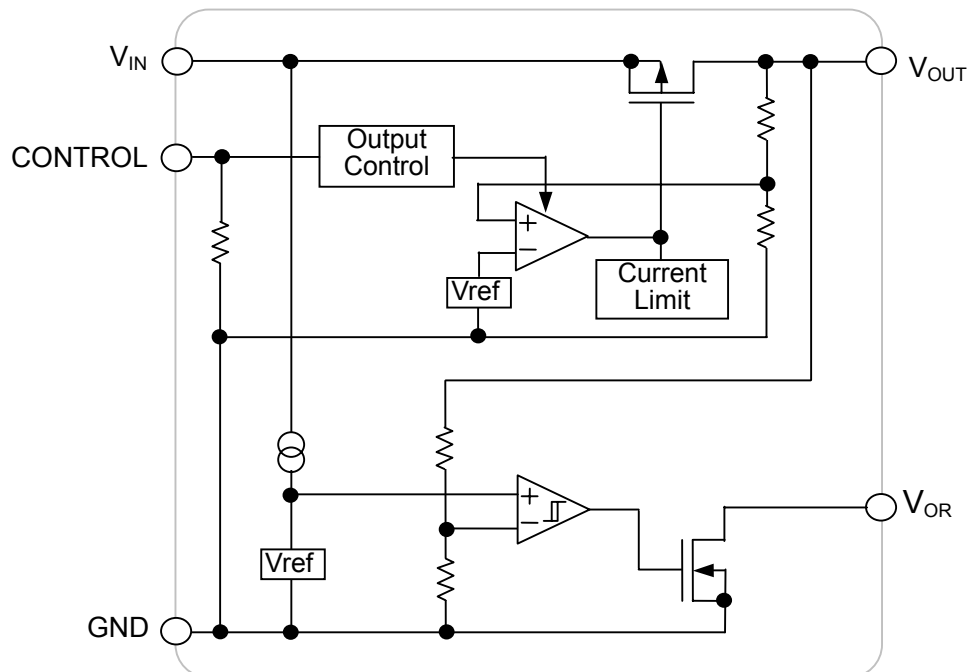

■ OUTPUT VOLTAGE/ DETECTION VOLTAGE

Device Name	Output Voltage	Detection Voltage
NJU7271F1813A	1.8V	1.3V
NJU7271F3328A	3.3V	2.8V
NJU7271F0543A	5.0V	4.3V

Output voltage options available : 1.8 ~ 5.0V (0.1V step)

Detection voltage options available : 1.3 ~ 4.5V (0.1V step)

■ ABSOLUTE MAXIMUM RATINGS

(Ta=25°C)

PARAMETER	SYMBOL	RATINGS	UNIT
Input Voltage	V_{IN}	+11	V
Control Voltage	V_{CONT}	+11(*1)	V
V_{OR} Pin Output Voltage	V_{OR}	$V_{SS} - 0.3 \sim +11$	V
V_{OR} Pin Output Current	I_{OR}	50	mA
Power Dissipation	P_D	200(*2) 350(*3)	mW
Operating Temperature	Topr	-40 ~ +85	°C
Storage Temperature	Tstg	-40 ~ +125	°C

(*1): Device itself

(*2): Mounted on glass epoxy board based on EIA/JEDEC. (114.3x76.2x1.6mm: 2Layers)

■ ELECTRICAL CHARACTERISTICS ($V_{IN}=V_O+1$, $C_{IN}=0.1\mu F$, $C_O=0.1\mu F$, $T_a=25^\circ C$)

PARAMETER	SYMBOL	TEST CONDITION	MIN.	TYP.	MAX.	UNIT	
General Characteristics							
Quiescent Current	I_Q	$V_{CONT}=V_{IN}$, $I_O=0mA$	-	3.0	7.6	μA	
Quiescent Current at Control OFF	$I_{Q(OFF)}$	$V_{CONT}=0V$, $I_O=0mA$	-	0.1	1.0	μA	
Regulator Block							
Output Voltage	V_O	$I_O=30mA$	-1.0%	-	+1.0%	V	
Output Current	I_O	$V_O - 0.3V$	100	-	-	mA	
Line Regulation	$\Delta V_O/\Delta V_{IN}$	$V_{IN}=V_O+1V \sim V_O+6V(3.0 > V_O)$ $V_{IN}=V_O+1V \sim 9.0V(3.0 \leq V_O)$ $I_O=30mA$	-	-	0.30	%/V	
Load Regulation	$\Delta V_O/\Delta I_O$	$I_O=0 \sim 100mA$	-	-	0.15	%/mA	
Output Voltage Temperature Coefficient	$\Delta V_O/\Delta T_a$	$T_a=0 \sim 85^\circ C$, $I_O=10mA$	-	± 100	-	ppm/°C	
Control Voltage for ON-State	$V_{CONT(ON)}$		1.6	-	V_{IN}	V	
Control Voltage for OFF-State	$V_{CONT(OFF)}$		0	-	0.3	V	
Pull-down Resistance	R_{CONT}		2.0	5	10	M Ω	
Short Circuit Limit	I_{LIM}	$V_O=0V$	-	25	-	mA	
Input Voltage	V_{IN}		-	-	9	V	
Dropout Voltage	ΔV_{I-O}	$I_O=40mA$	$1.5V \leq V_O \leq 2.0V$	-	0.19	0.60	V
			$2.1V \leq V_O \leq 2.4V$	-	0.19	0.29	V
			$2.5V \leq V_O \leq 2.7V$	-	0.18	0.27	V
		$I_O=60mA$	$2.8V \leq V_O \leq 3.3V$	-	0.17	0.26	V
			$3.4V \leq V_O \leq 5.0V$	-	0.16	0.24	V
			$5.1V \leq V_O \leq 6.0V$	-	0.15	0.22	V

PARAMETER	SYMBOL	TEST CONDITION	MIN.	TYP.	MAX.	UNIT	
Reset Block							
Detection Voltage	V_{DET}		-1.0%	-	+1.0%	V	
Hysteresis Voltage	V_{HYS}		$V_{DET} \times 0.03$	$V_{DET} \times 0.05$	$V_{DET} \times 0.08$	V	
V_{OR} Pin Output Current	I_{OR}	Nch, $V_{DS}=0.5V$ $V_{CONT}=0V$	$V_{IN}=1.2V$	0.75	2.0	-	mA
			$V_{IN}=2.4V$ ($V_{DET} \geq 2.7V$ Version)	4.5	7.0	-	mA
Output Leak Current	I_{LEAK}	$V_{IN}=V_{OR}=V_{CONT}=9V$	-	-	0.1	μA	
Detection Voltage	$\Delta V_{DET}/\Delta Ta$	$Ta=0 \sim 85^{\circ}C$	-	± 100	-	ppm/ $^{\circ}C$	
Operating Voltage(*4)	V_{OPL}	$R_L=100k\Omega$	-	-	0.8	V	

(*3): The value condition that V_{OR} become 10% or less of V_{IN} .

■ TIMING CHART

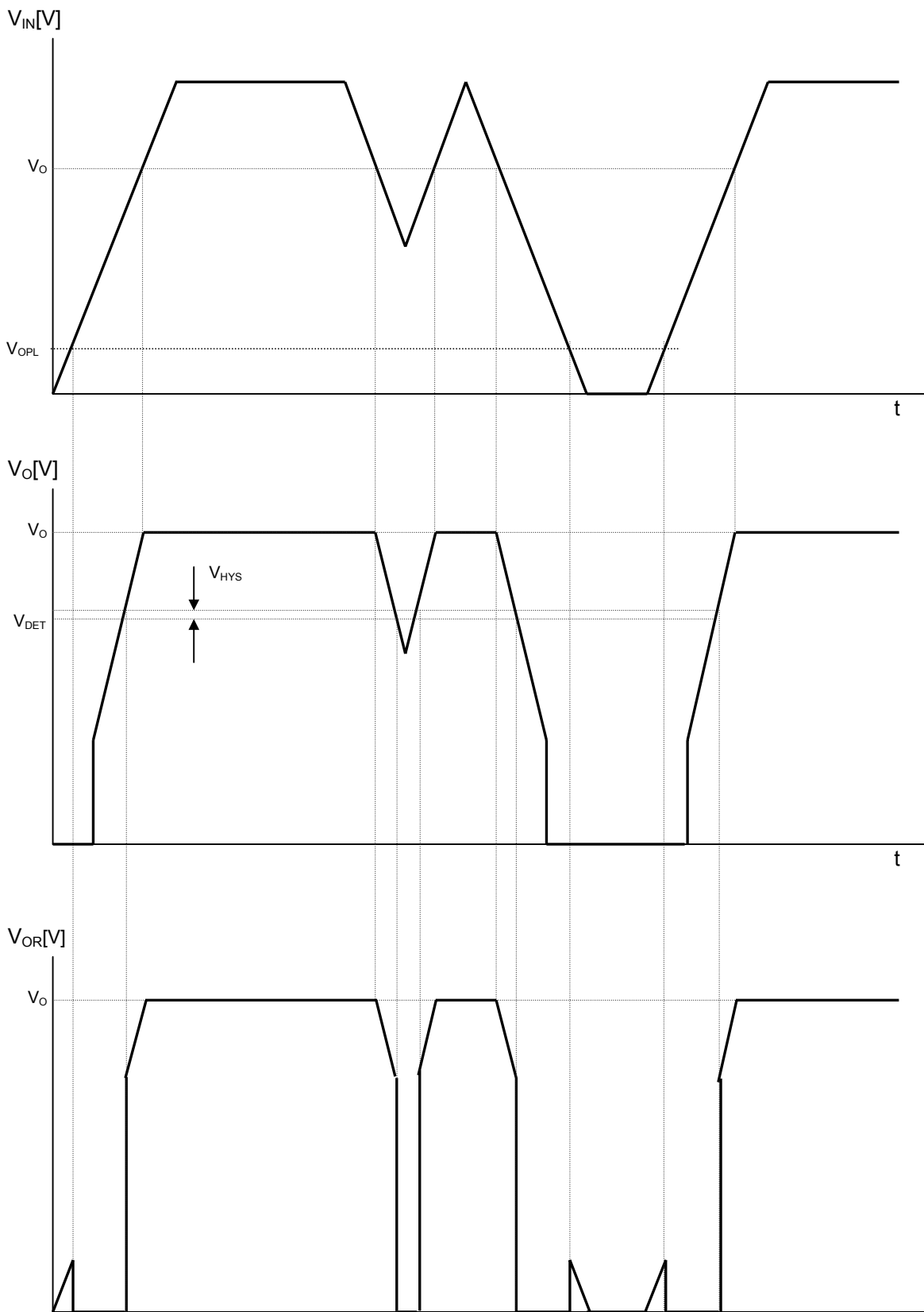

* V_{OR} is the case where a pull-up is carried out to V_{IN} through resistance.

■ TEST CIRCUIT

① COMMON TEST CIRCUIT

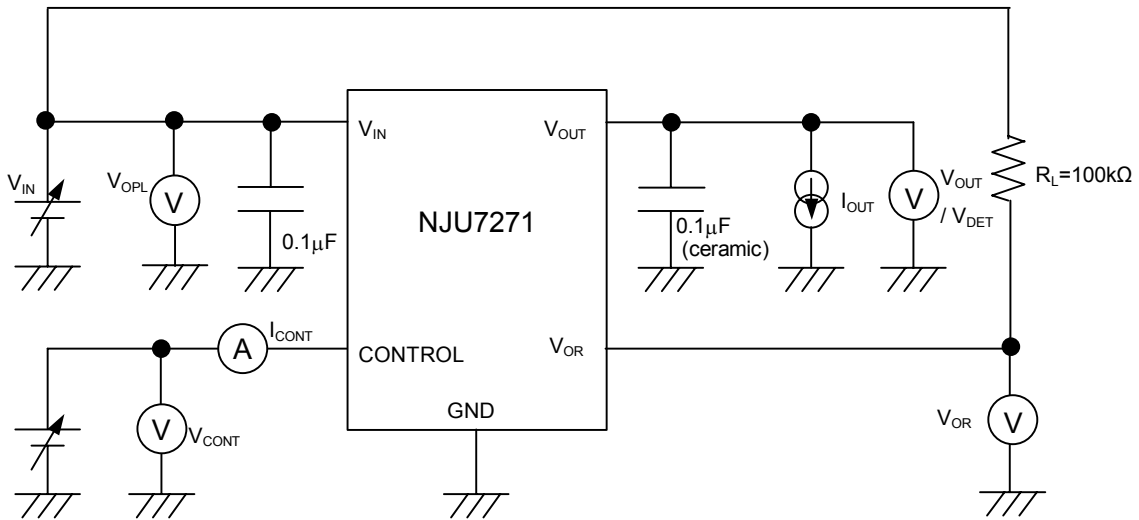

② OUTPUT CURRENT/OUTPUT LEAK CURRENT TEST CIRCUIT

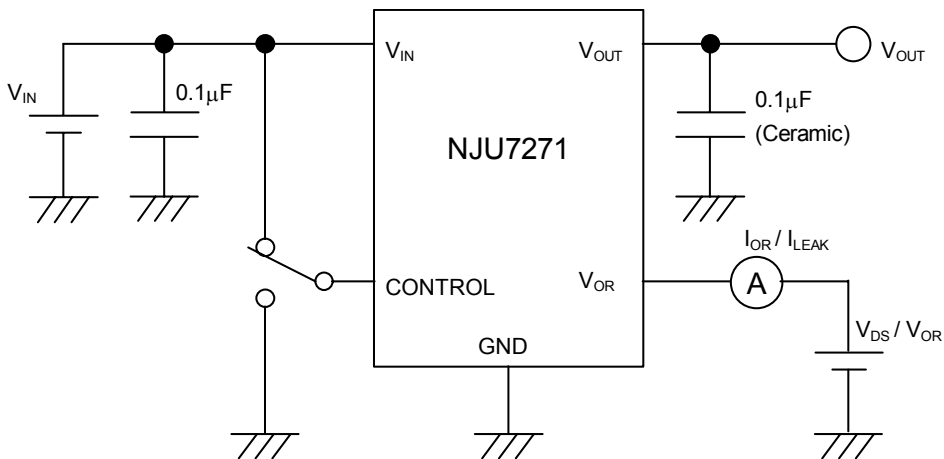

③ QUIESCENT CURRENT TEST CIRCUIT

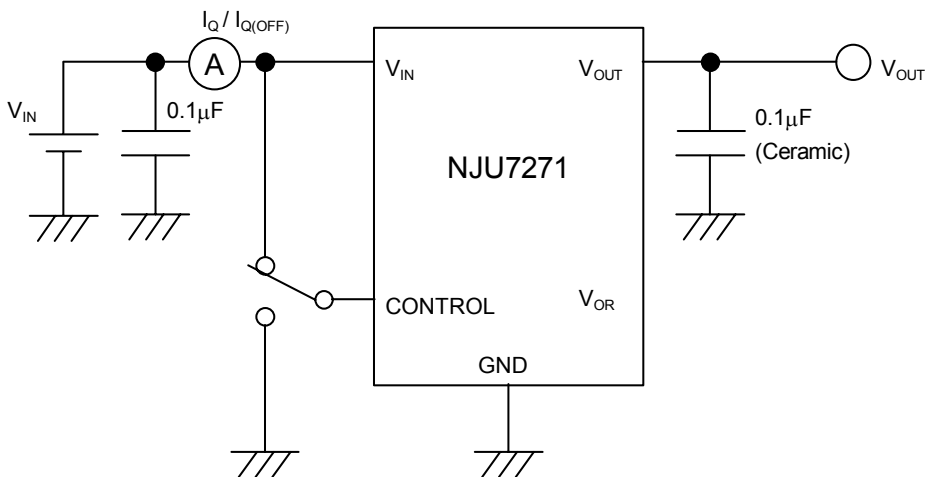

■ TYPICAL APPLICATION

① In case that ON/OFF Control is not required:

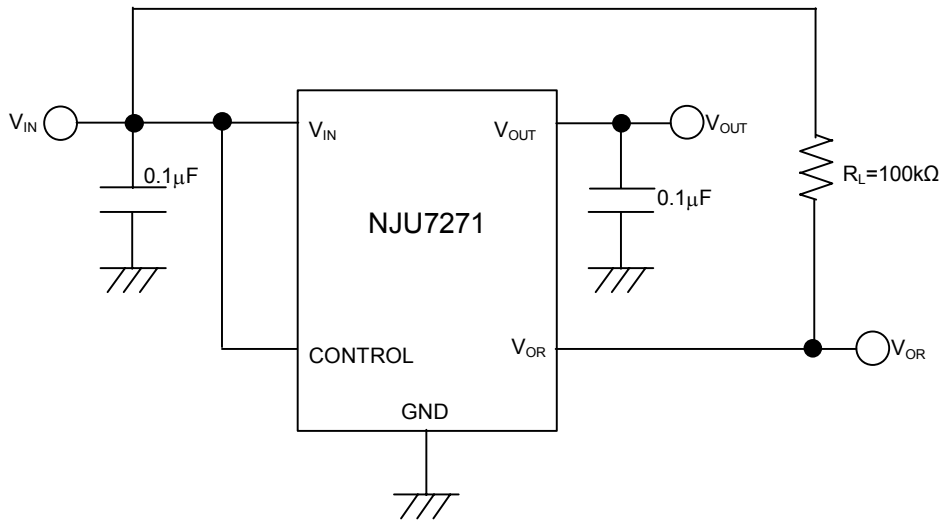

Connect control terminal to V_{IN} terminal.

② In use of ON/OFF Control:

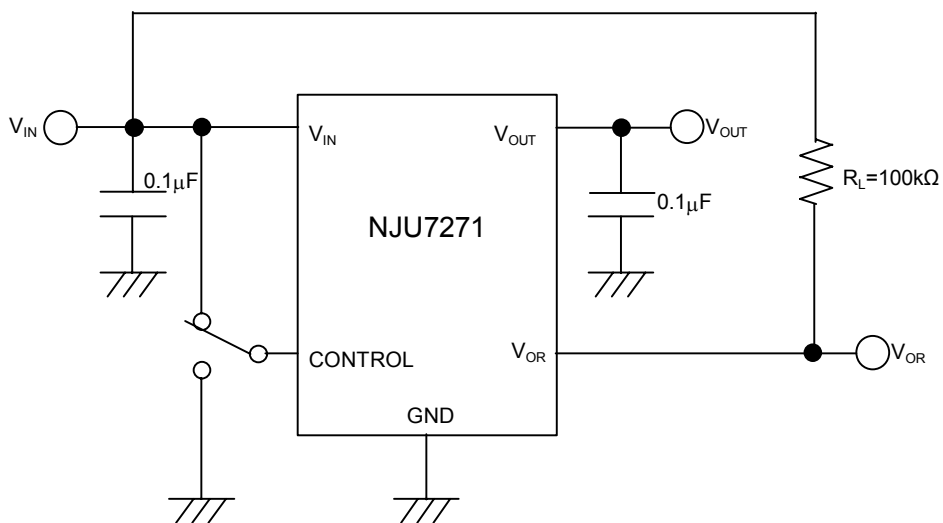

State of control terminal:

- “H” → output is enabled.
- “L” or “open” → output is disabled.