

Low power dual operational amplifier

Features

- Internally frequency-compensated
- Large DC voltage gain: 100dB typ.
- Wide bandwidth (unity gain): 1.1MHz typ.
- Low Operating Current : 0.7mA typ.
- Low input bias current: 20nA typ.
- Low input offset voltage: 0.5mV typ.
- Input common-mode voltage range includes negative rails
- Differential input voltage range equal to the power supply voltage
- Large output voltage swing 0V to ($V_{CC}^+ - 1.5V$)
- Internal ESD protection
Human body model (HBM) $\pm 2000V$ typ.

Description

The NJM358C consist of two independent, high-gain, internally frequency-compensated op-amps, specifically designed to operate from a single power supply over a wide range of voltages. The low-power supply drain is independent of the magnitude of the power supply voltage.

Application areas include transducer amplifiers, DC gain blocks and all the conventional op-amp circuits, which can now be more easily implemented in single power supply systems. For example, these circuits can be directly supplied with the standard +5V, which is used in logic systems and will easily provide the required interface electronics with no additional power supply.

In linear mode, the input common-mode voltage range includes ground and the output voltage can also swing to ground, even though operated from only a single power supply voltage.

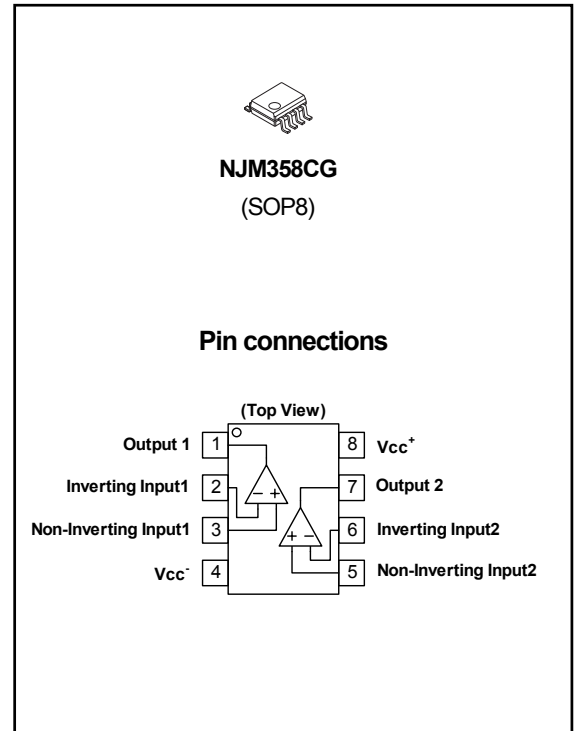

1 Schematic diagram

Figure 1. Schematic diagram (1/2 NJM358C)

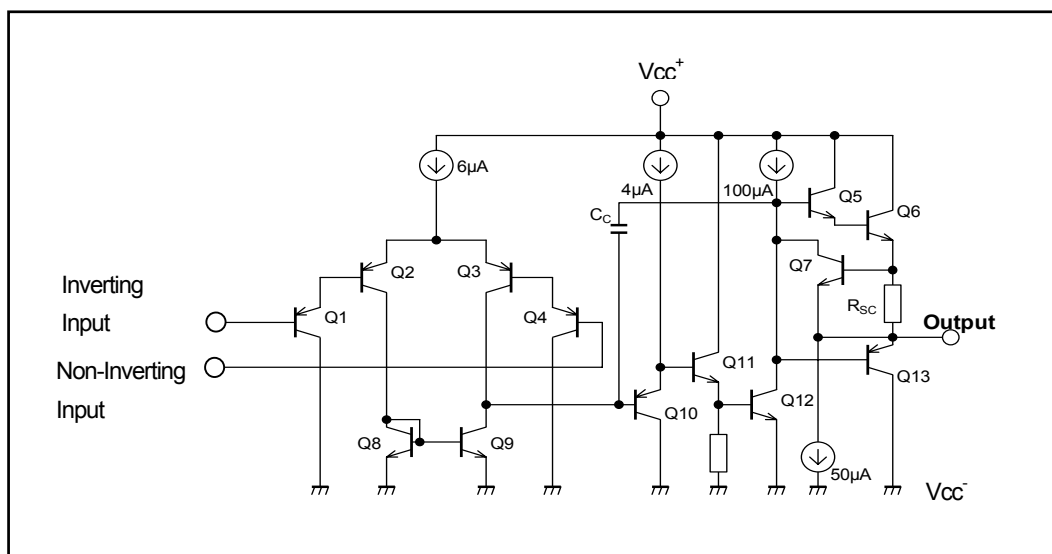

2 Absolute maximum ratings and operating conditions

Table1. Absolute maximum ratings

(Tamb=25°C)

Symbol	Parameter	RATINGS	Unit
V _{CC}	Supply voltage (V _{CC} ⁺ - V _{CC} ⁻)	32	V
V _{IN}	Input voltage ⁽¹⁾	-0.3 to 32	V
V _{ID}	Differential input voltage	±32	V
-	Output short-circuit duration ⁽²⁾	Infinite	-
I _{IN}	Input current ⁽³⁾	5mA in DC or 50mA in AC (duty cycle = 10%, T=1s)	mA
T _{stg}	Storage temperature range	-65 to +150	°C
T _J	Maximum junction temperature	150	°C
P _D	Power Dissipation	690 ⁽⁵⁾ 1000 ⁽⁶⁾	mW
θ _{ja}	Thermal resistance junction to ambient ⁽⁴⁾	180 ⁽⁵⁾ 122 ⁽⁶⁾	°C /W
ψ _{jt}	Thermal resistance junction to top surface of IC package ⁽⁴⁾	49 ⁽⁵⁾ 43 ⁽⁶⁾	°C /W

- Input voltage is the voltage should be allowed to apply to the input terminal independent of the magnitude of V_{CC}⁺. The normal amplifier operation input voltage is within "Common Mode Input Voltage Range" specified in the Electrical characteristics.
- Short-circuits from the output to V_{CC}⁺ can cause excessive heating if V_{CC} > 15V. Destructive dissipation can result from simultaneous short circuits on all amplifiers.
- This input current only exists when the voltage at any of the input leads is driven negative. It is due to the collector-base junction of the input PNP transistor becoming forward-biased and thereby acting as input diode clamp. In addition to this diode action, there is NPN parasitic action on the IC chip. This transistor action can cause the output voltages of the Op-amps to go to the V_{CC} voltage level (or to ground for a large overdrive) for the time during which an input is driven negative.
- Short-circuit can cause excessive heating and destructive dissipation. Values are typical.
- EIA/JEDEC STANDARD Test board (76.2 x 114.3 x 1.6mm, 2layers, FR-4) mounting
- EIA/JEDEC STANDARD Test board (76.2 x 114.3 x 1.6mm, 4layers, FR-4) mounting

3. Operating conditions

Table2. Operating conditions

(Tamb=25°C)

Symbol	Parameter	Value	Unit
V _{CC}	Supply voltage (V _{CC} ⁺ - V _{CC} ⁻)	3 to 30	V
V _{icm}	Common mode input voltage range	V _{CC} ⁻ - 0.3 to V _{CC} ⁺ - 1.5	V
T _{oper}	Operating free-air temperature range	-40 to +85	°C

4 Electrical characteristics

Table3. $V_{CC}^+ = +5V$, $V_{CC}^- = 0V$, $T_{amb} = +25^\circ C$, $T_{min} = 0^\circ C$, $T_{max} = 70^\circ C$ (unless otherwise specified)

Symbol	Parameter	Min.	Typ.	Max.	Unit
V_{io}	Input offset voltage ⁽¹⁾				
	T_{amb}	-	0.5	7	mV
	$T_{min} < T_{amb} < T_{max}$ ⁽⁵⁾	-	-	9	
DV_{io}	Input offset voltage drift $T_{min} < T_{amb} < T_{max}$ ⁽⁵⁾	-	7	30	$\mu V/^\circ C$
I_{io}	Input offset current				
	T_{amb}	-	2	30	nA
	$T_{min} < T_{amb} < T_{max}$ ⁽⁵⁾	-	-	40	
DI_{io}	Input offset current drift $T_{min} < T_{amb} < T_{max}$ ⁽⁵⁾	-	-	300	$pA/^\circ C$
I_{ib}	Input bias current ⁽²⁾				
	T_{amb}	-	20	150	nA
	$T_{min} < T_{amb} < T_{max}$ ⁽⁵⁾	-	-	200	
A_{vd}	Large signal voltage gain				
	T_{amb} , $V_{CC}^+ = +15V$, $R_L = 2k\Omega$, $V_o = 1.4V$ to $11.4V$	50	100	-	V/mV
	$T_{min} < T_{amb} < T_{max}$ ⁽⁵⁾	25	-	-	
SVR	Supply voltage rejection ratio				
	T_{amb} , $V_{CC}^+ = 5V$ to $30V$, $R_s < 10k\Omega$	65	100	-	dB
	$T_{min} < T_{amb} < T_{max}$ ⁽⁵⁾	65	-	-	
I_{CC}	Supply current, all amp, no load				
	$T_{min} < T_{amb} < T_{max}$ ⁽⁵⁾ , $V_{CC}^+ = 5V$	-	0.7	1.2	mA
	$T_{min} < T_{amb} < T_{max}$ ⁽⁵⁾ , $V_{CC}^+ = 30V$	-	-	2	
V_{icm}	Input common mode voltage range				
	T_{amb} , $V_{CC}^+ = +30V$ ⁽³⁾	0	-	$V_{CC}^+ - 1.5$	V
	$T_{min} < T_{amb} < T_{max}$ ⁽⁵⁾	0	-	$V_{CC}^+ - 2$	

Table3. $V_{CC}^+ = +5V, V_{CC}^- = 0V, T_{amb} = +25^\circ C, T_{min} = 0^\circ C, T_{max} = 70^\circ C$ (unless otherwise specified)

Symbol	Parameter	Min.	Typ.	Max.	Unit
CMR	Common mode rejection ratio				
	$T_{amb}, R_S < 10k\Omega$ $T_{min} < T_{amb} < T_{max}^{(5)}$	70 60	100 -	- -	dB
I_{source}	Output current source $T_{amb}, V_{CC}^+ = 15V, V_O = +2V, V_{id} = +1V$	20	40	-	mA
I_{sink}	Output sink current				
	$T_{amb}, V_{CC}^+ = 15V, V_O = +2V, V_{id} = -1V$ $T_{amb}, V_{CC}^+ = 15V, V_O = +0.2V, V_{id} = -1V$	10 12	20 50	- -	mA μA
V_{OH}	High level output voltage				
	$T_{amb}, R_L = 2k\Omega, V_{CC}^+ = 30V$	26	27	-	V
	$T_{min} < T_{amb} < T_{max}^{(5)}$	26	-	-	
	$T_{amb}, R_L = 10k\Omega, V_{CC}^+ = 30V$	27	28	-	
$T_{min} < T_{amb} < T_{max}^{(5)}$	27	-	-		
V_{OL}	Low level output voltage				
	$T_{amb}, R_L = 10k\Omega$ $T_{min} < T_{amb} < T_{max}^{(5)}$	- -	5 -	20 20	mV
SR	Slew rate $T_{amb}, V_{CC}^+ = 15V, V_i = 0.5 \text{ to } 3V, R_L = 2k\Omega,$ $C_L = 100pF, \text{ unity gain}$	-	0.6	-	V/ μs
GBP	Gain bandwidth product $T_{amb}, V_{CC}^+ = 30V, f = 100kHz, V_{in} = 10mV,$ $R_L = 2k\Omega, C_L = 100pF$	-	1.1	-	MHz
THD	Total harmonic distortion $T_{amb}, f = 1kHz, A_V = 20dB, R_L = 2k\Omega, V_O = 2V_{pp},$ $C_L = 100pF$	-	0.02	-	%
e_n	Equivalent input noise voltage $T_{amb}, f = 1kHz, R_S = 100\Omega, V_{CC}^+ = 30V$	-	30	-	nV/ \sqrt{Hz}
V_{O1}/V_{O2}	Channel separation ⁽⁴⁾ $T_{amb}, 1kHz < f < 20kHz$	-	120	-	dB

1. $V_O = 1.4V, R_S = 0\Omega, 5V < V_{CC}^+ < 30V, 0 < V_{ic} < V_{CC}^+ - 1.5V.$

2. The direction of the input current is out of the IC.

3. The input common-mode voltage of either input signal voltage should not be allowed to go negative by more than 0.3V. The upper end of the common-mode voltage range is $V_{CC}^+ - 1.5V$, but either or both inputs can go to +32V without damage.

4. Due to the proximity of external components, ensure that stray capacitance between these external parts dose not cause coupling.

5. This parameter is not 100% test.

■ TYPICAL CHARACTERISTICS

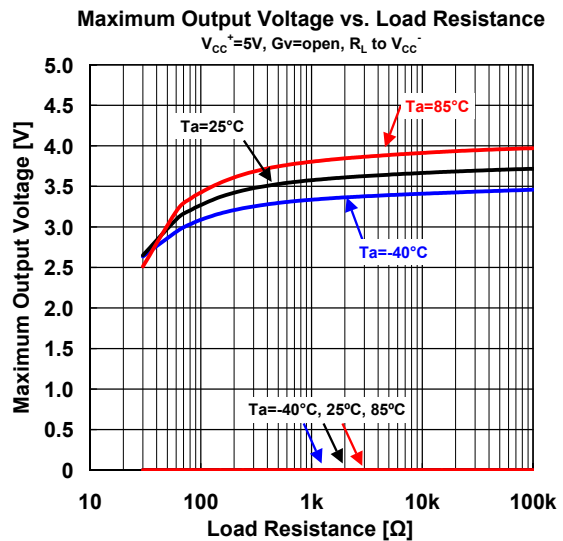
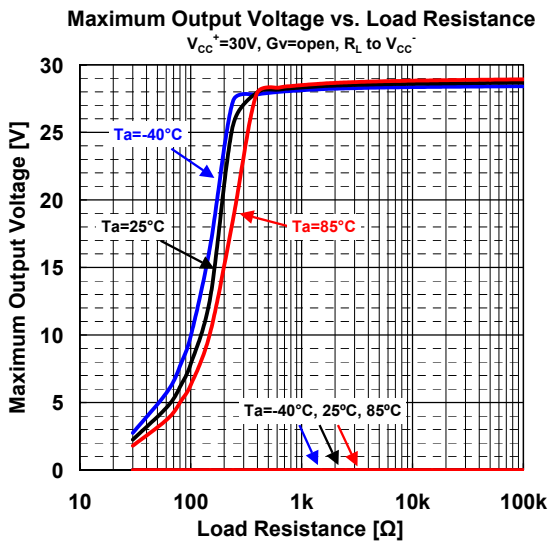
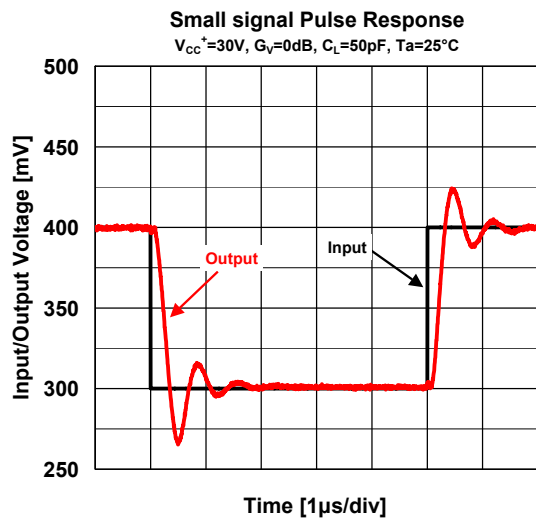
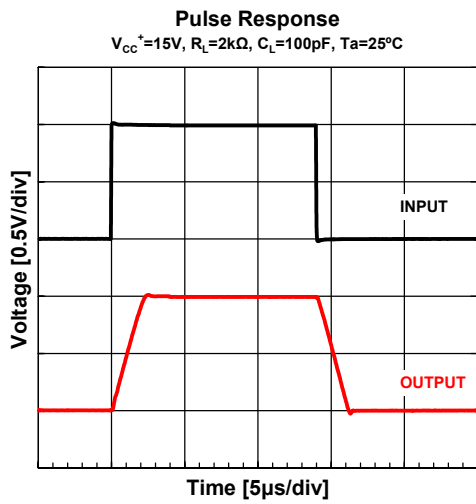
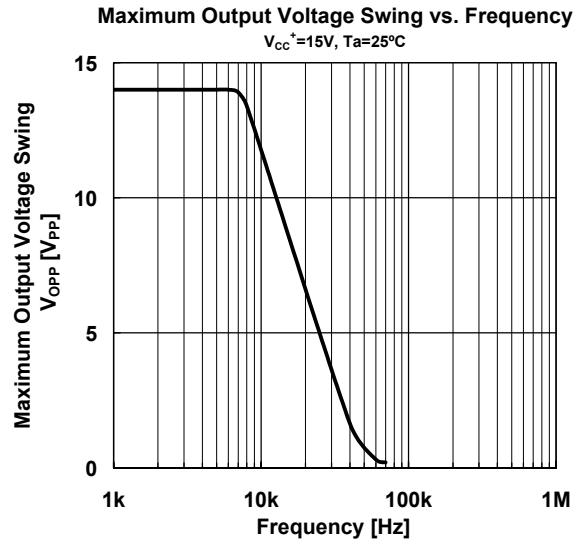
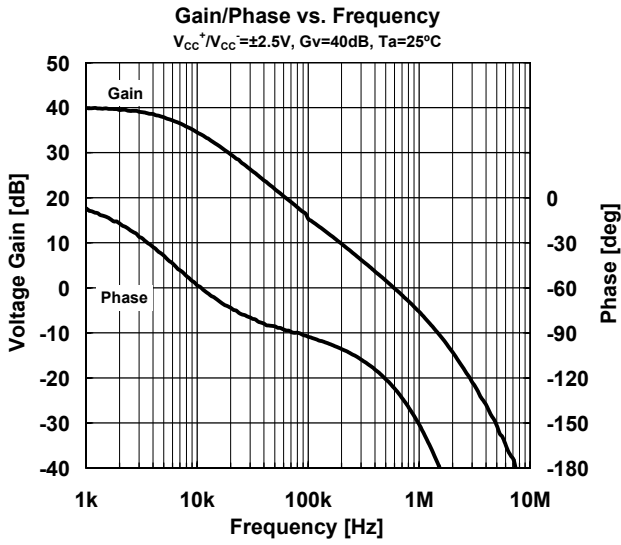

■ TYPICAL CHARACTERISTICS

Maximum Output Voltage vs. Load Resistance
 $V_{CC}^+ = 3V$, $G_V = \text{open}$, R_L to V_{CC}^-

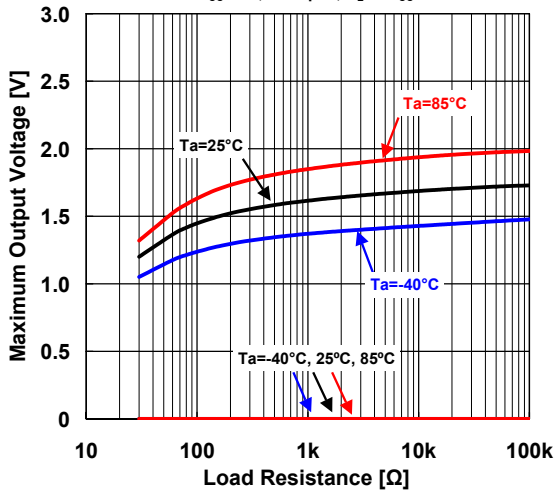

Maximum Output Voltage vs. Output Current
 $V_{CC}^+ = 15V$

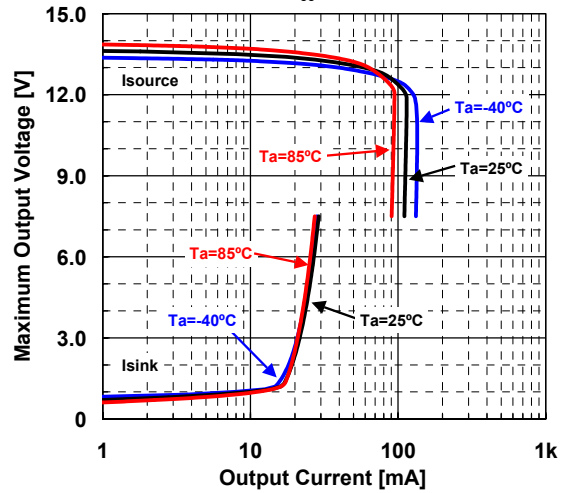

Output Voltage vs. Output Sink Current
 $V_{CC}^+ = 5V$, $T_a = 25^\circ C$

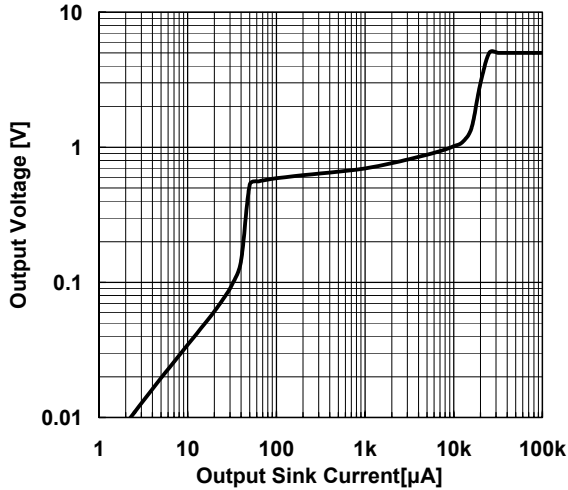

Input Voltage Range vs. Supply Voltage
 $T_a = 25^\circ C$

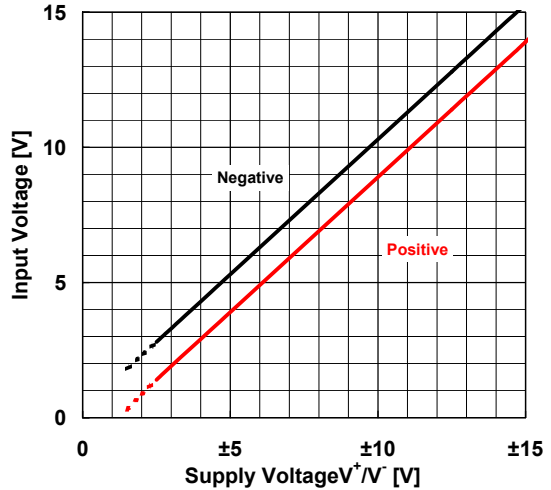

Supply Current vs. Supply Voltage
 $R_L = \text{open}$

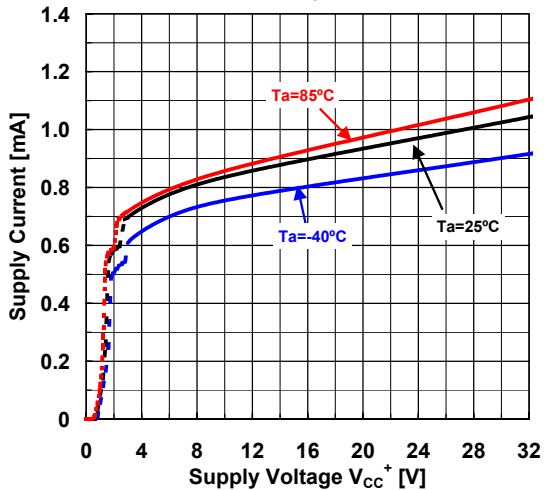

Supply Current vs. Temperature
 $R_L = \text{open}$

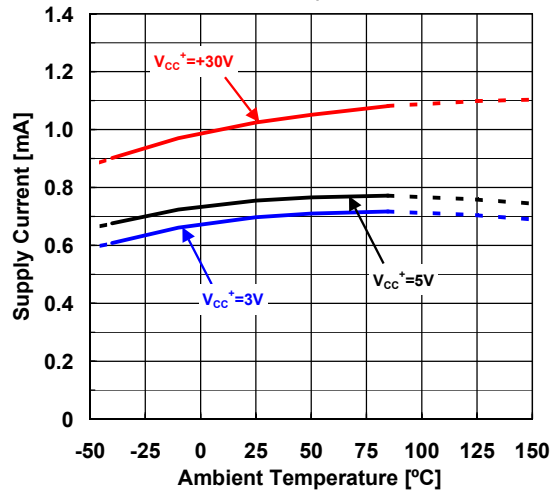

■ TYPICAL CHARACTERISTICS

Input Offset Voltage vs. Supply Voltage

$$V_{CM} = V_{CC}^+ / 2$$

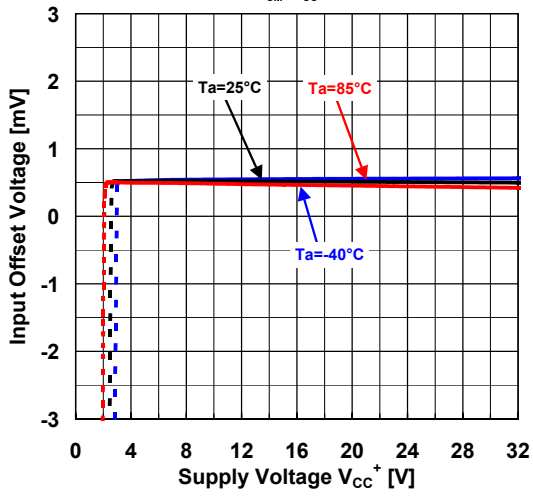

Input Offset Voltage vs. Temperature

$$V_{CM} = V_{CC}^+ / 2$$

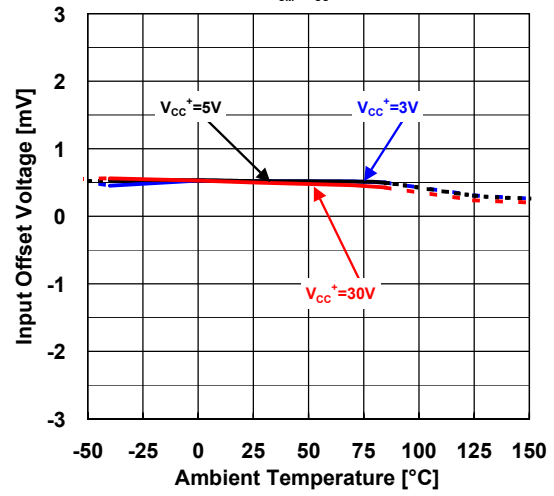

Input Offset Voltage vs. Common-Mode Input Voltage

$$V_{CC}^+ = 30V$$

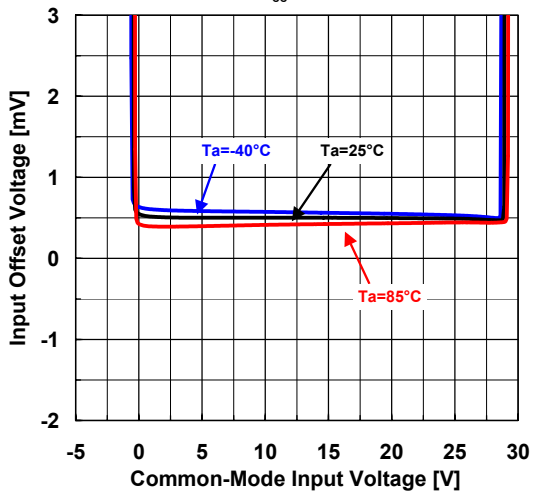

Input Offset Voltage vs. Common-Mode Input Voltage

$$V_{CC}^+ = 5V$$

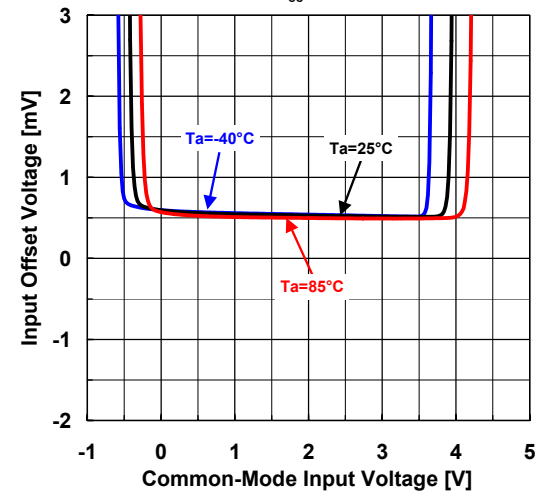

Input Offset Voltage vs. Common-Mode Input Voltage

$$V_{CC}^+ = 3V$$

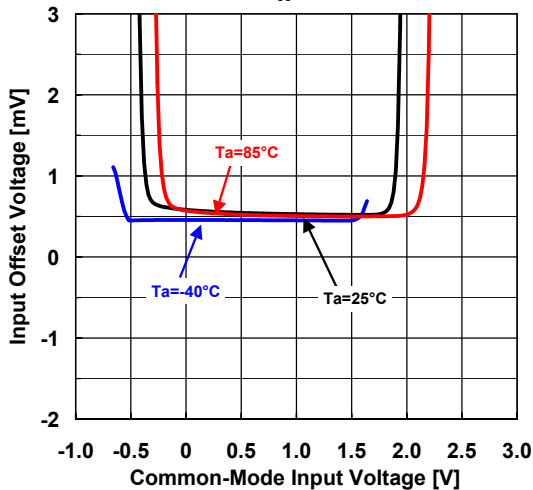

Input Bias Current vs. Temperature

$$V_{CM} = V_{CC}^+ / 2$$

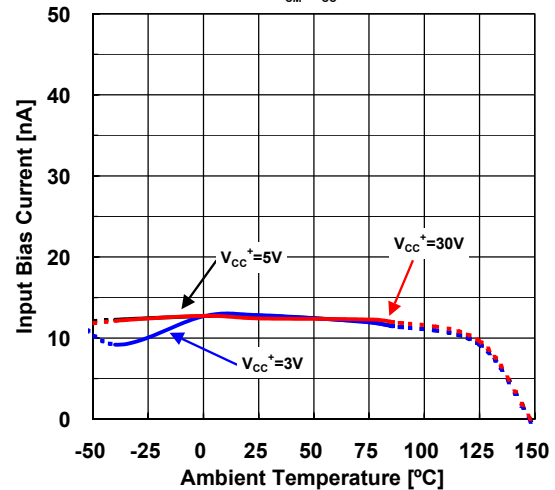

■ TYPICAL CHARACTERISTICS

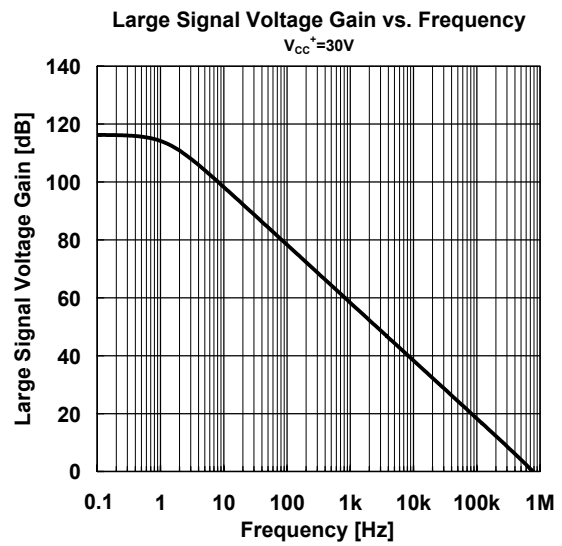
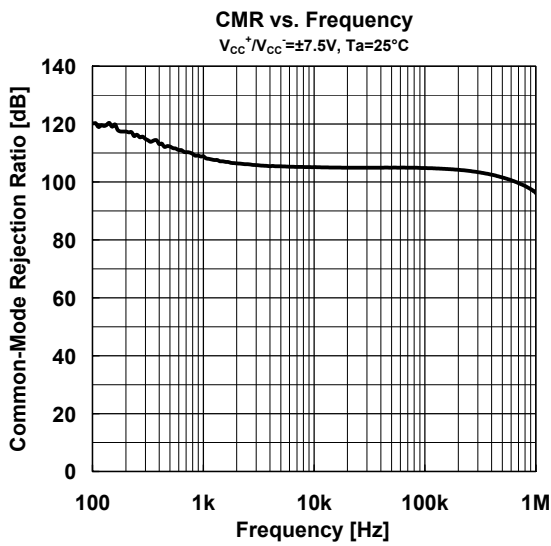
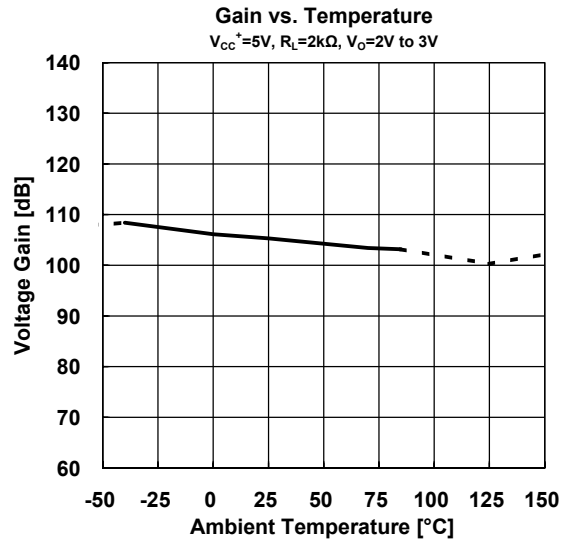
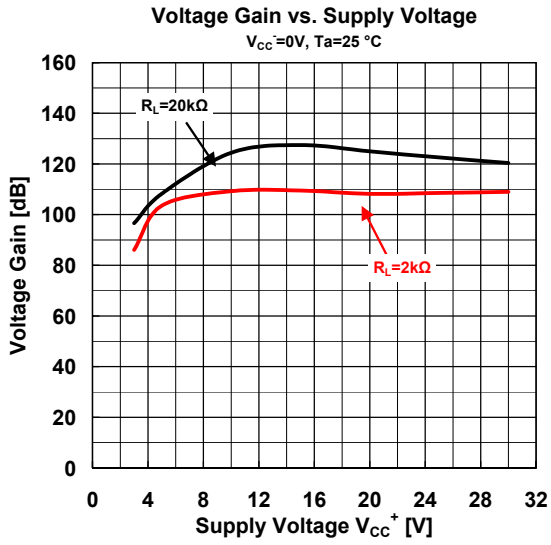

■ PACKAGE DIMENSIONS

SOP8

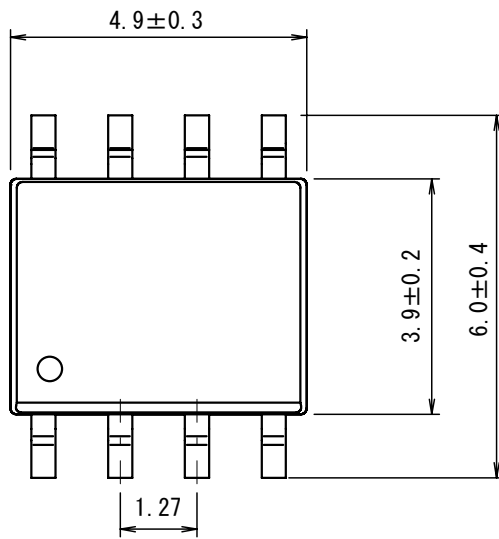

UNIT: mm

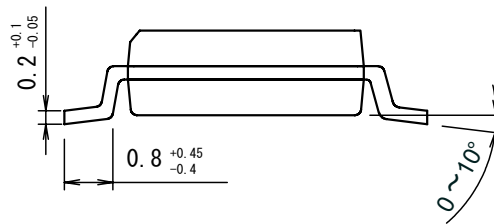
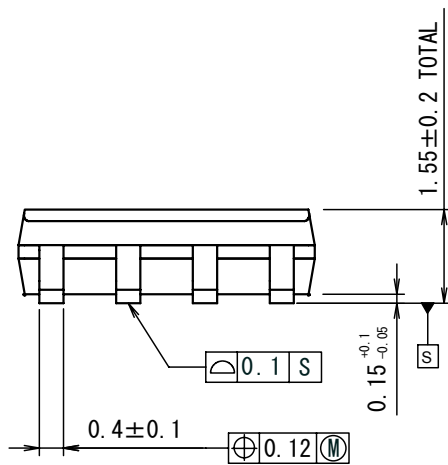

[CAUTION]
The specifications on this databook are only given for information, without any guarantee as regards either mistakes or omissions. The application circuits in this databook are described only to show representative usages of the product and not intended for the guarantee or permission of any right including the industrial rights.