

**TYPE WC 2.5X2.0 VOLTAGE CONTROLLED TEMPERATURE COMPENSATED CRYSTAL OSCILLATOR**

**WC255BG0016.368000**

VER. 03 16-Apr-13

**ELECTRICAL SPECIFICATIONS**

**SRe Part Number : WC255BG0016.368000**

Item	Symbol	Specifications	Units	Notes
Nominal Frequency	Fo	16.368000	MHz	
Operating Temperature Range	TR	-30 to +85	°C	
Storage Temperature Range		-40 to +85	°C	
Supply Voltage	V <sub>DD</sub>	+3.0 ± 5.0%	V	
Frequency Stability	FT	± 1.0	ppm	vs. Temperature (Refer to the mid-point between minimum and maximum frequency values over the specified temperature range)
Frequency Stability		± 0.2	ppm	vs. Load varied 10pF//10kΩ±10%
Frequency Stability		± 0.1	ppm	vs. Supply Voltage varied V <sub>DD</sub> ±5% at 25°C
Frequency Tolerance		± 2.0	ppm	Max. After 2 times reflow (Refer to nominal frequency)
Static Temperature Hysteresis		± 0.6	ppm	Max.
Aging		±1	ppm	per year at 25°C
Logic Type	LT	Clipped Sinewave		
Supply Current	I <sub>DD</sub>	1.5	mA	Max.
Start Up Time v.s Output Level		2.5	msec	Max, 90% of specified output level
Output Voltage		0.8 to 1.4	Vp-p	
Output Load Resistance		10	KΩ	9KΩ Min / 11KΩ Max
Output Load Capacitance		10	pF	9pF Min / 11pF Max
Harmonics		-7	dBc	Max.
Phase Noise		-134	dBc/Hz	Max, at 1kHz offset
Frequency Control Range		±5 to ±15	ppm	V <sub>cont</sub> =0.5V to 2.5V
Linearity		10	%	Max
Input Resistance		500	KΩ	Min
Modulation Bandwidth		10	KHz	Min

※ This product doesn't include harmful substance that stipulated by SONY SS-00259 Level 1 and S-AT2-001 Level 1 standard. RoHS Compliant (Pb - Free).



**TEST CIRCUIT**

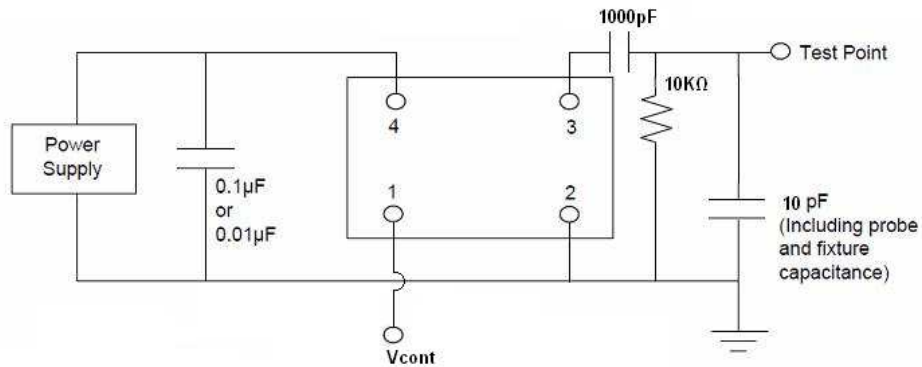

**RELIABILITY SPECIFICATIONS**

**ENVIRONMENTAL:**

- a) THERMAL SHOCK: MIL-STD-883, Method 1011, Condition A
- b) MOISTURE RESISTANCE: MIL-STD-883, Method 1004
- c) VIBRATION: MIL-STD-883, Method 2007, Condition A
- d) RESISTANCE TO SOLDERING HEAT: J-STD-020D Table 5-2 Pb-free devices (except 2 cycles max)
- e) HAZARDOUS SUBSTANCE: Pb - free and RoHS Compliant.

**MECHANICAL:**

- a) SHOCK: MIL-STD-883, Method 2002, Condition B
- b) SOLDERABILITY: JESD22-B102-D Method 2 (Preconditioning E)
- c) TERMINAL STRENGTH: MIL-STD-883, Method 2004, Test Condition D
- d) GROSS LEAK: MIL-STD-883, Method 1014, Condition C
- e) FINE LEAK: MIL-STD-883, Method 1014, Condition A2,  $R1=2 \times 10^{-8}$  atm cc/s
- f) SOLVENT RESISTANCE: MIL-STD-202, Method 215

**SUGGESTED IR REFLOW PROFILE**

\*As per IPC-JEDEC J-STD-020D

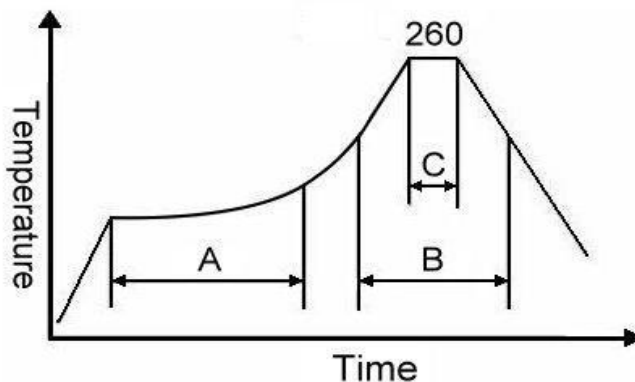

Note:

	Stage	Temperature	Time
A	Preheat	150~200°C	60~120 Sec
B	Primary Heat	217°C	60~150 Sec
C	Peak	260°C	10 Sec

**MARKING**

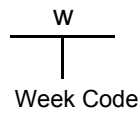
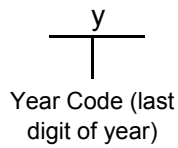
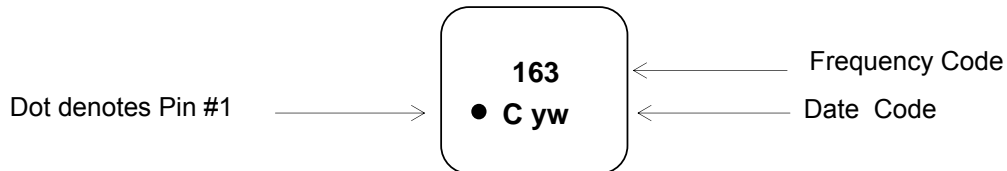

**MECHANICAL DRAWINGS ( Scale: None. Dimensions are in mm.)**

Recommended Land Pattern

(TOP VIEW)

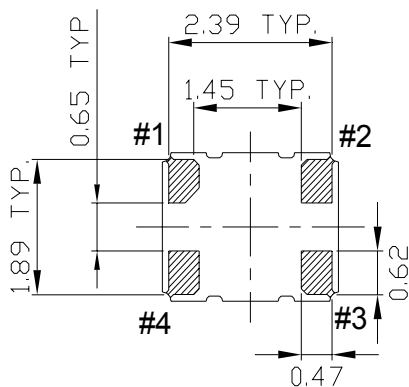
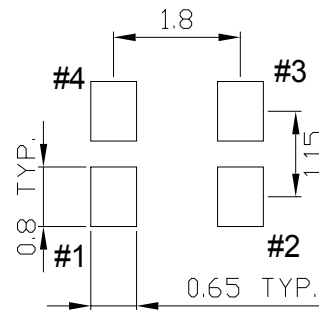
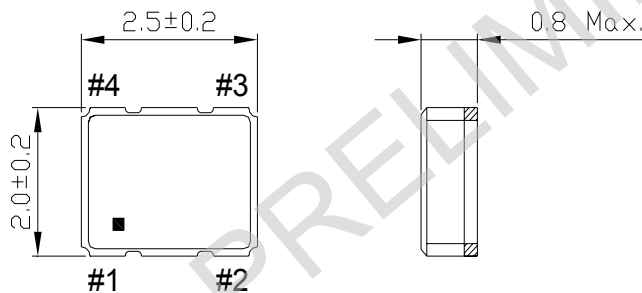

Pin No.	Connections
1	Vcont
2	GND
3	OUTPUT
4	VDD

**TAPE&REEL**

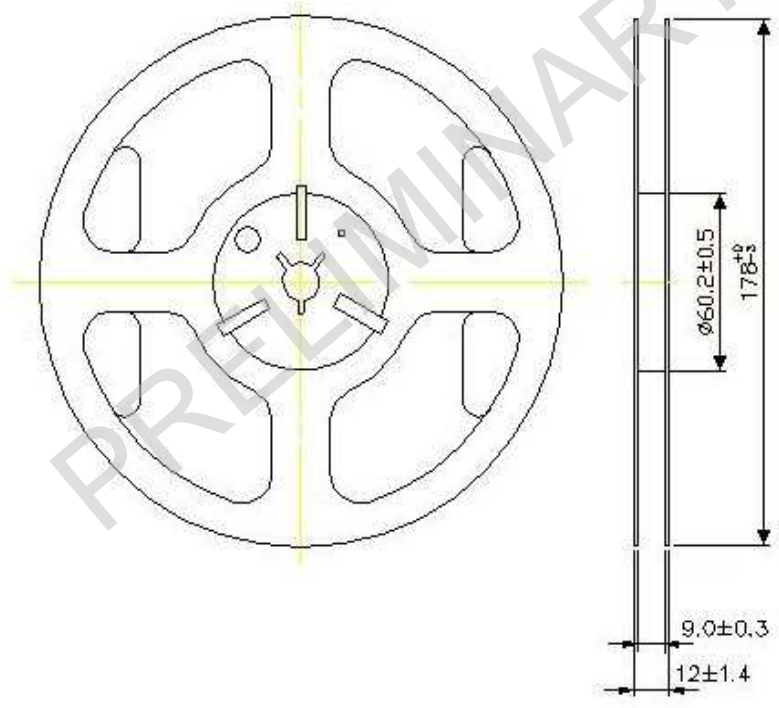
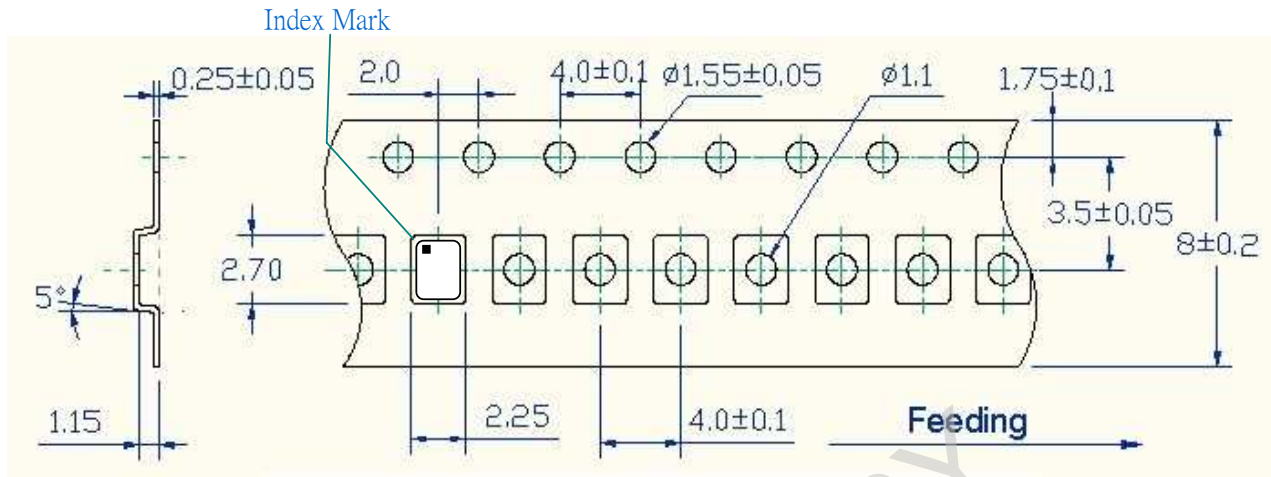

1. 230mm minimum leader which consist of carrier and/or tape followed by a minimum of 160mm of empty carrier tape sealed with cover tape.
2. 160mm minimum trailer of empty carrier tape sealed with cover tape.

**PACKING**

