

1.8V ~ 3.3VDC Clipped Sinewave TCXO

WT325



3.2 x 2.5mm Ceramic SMD

Typical Frequencies available MHz:		
16.367667	16.369	19.200
25.000	26.000	40.000

Product Features

- Low Current
- Tight temperature stability
- Clipped Sinewave output levels
- Excellent Phase Noise
- Industrial Temperature Range
- Pb-free and RoHS/Green compliant
- Fast lead time

Product Description

The WT325 TCXO series is a high performance temperature compensated oscillator with a clipped sinewave output for a very low operating supply current. It supports various power supply voltages, stabilities and other features. It is designed to meet existing application requirements.

Applications

- Networking systems
- Networking
- GPS/Navigation
- Metering
- Mobile and wireless
- Handset

Package: (scale-none, dimensions in mm)

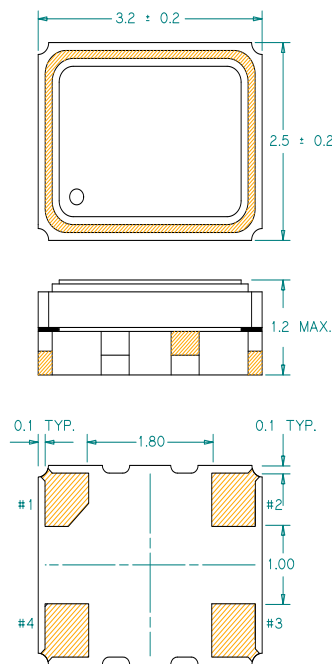

Recommended Land Pattern:

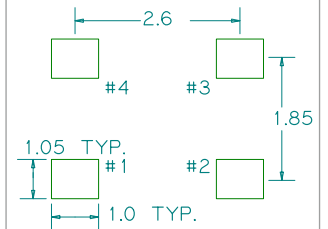

Pin Functions:

Pin	Function
1	Ground
2	Ground
3	Output
4	V _{DD}

Part Ordering Information:

WT325 V X FFFF.FFFFFFF

Voltage:	Stability and Temp Range:				Frequency: FFFFFFFF MHz, "4 digits/decimal/6 digits" format
	Temp Range	A	F	K	
1 = +3.3V	-20/+70C	A	F	K	P
2 = +2.5V		B	G	L	Q
3 = +1.8V		C	H	M	R
4 = +1.5V		D	I	N	S
B = +3.0V		E	J	O	T
C = +2.8V			W	X	Z
D = +2.7V				Y	
E = +2.85V					
F = +2.75V					
G = +2.4V					

Following the above format, PSE Technology Corporation part numbers will be assigned upon confirmation of exact customer requirements.



Electrical Performance

Parameter		Min.	Typ.	Max.	Units	Notes
Output Frequency		10		40	MHz	
Supply Voltage		1.8		3.3	V	See ordering options, VDD ±5%
Supply Current				2.0	mA	Output Frequency ≤ 30 MHz
				2.1	mA	Output Frequency > 30 MHz
Output Voltage Level		0.8		1.4	V	Pk-Pk
Output Load	Resistance	9	10	11	kΩ	
	Capacitance	9	10	11	pF	
Frequency Stability	vs Temperature	±0.5		±5.0	ppm	See ordering options
	vs Load			±0.2	ppm	±10% load change
	vs Voltage			±0.1	ppm	±5% supply voltage change at typical load
Frequency Aging				±1.0	ppm	First year, +25°C
Frequency Tolerance After Two Reflows				±2.0	ppm	@ +25°C±3°C after one hour recovery
Harmonics				-7	dBc	
Operating Temperature Range		-30		85	°C	See ordering options
Storage Temperature Range		-40		85	°C	
Phase Noise at 1KHz offset			-128		dBc/Hz	At 26MHz

Notes:

- For specifications other than those listed, please contact sales.
- Not all combinations of V_{DD}, Operating Temperature Range, Frequency Stability and Output Frequency are available.
- Frequency Stability vs. Temperature is reference to the mid-point between minimum and maximum frequency values over the specified Operating Temperature Range
- Frequency Stability vs. Voltage and vs. Load changes are reference to the Nominal Frequency at 25°C

For the latest product information visit: <http://www.pericom.com/products/crystals-and-crystal-oscillators/tcxo/?part=WT325>

For test circuit go to: http://www.pericom.com/assets/sre/TCXO_CLIPPEDESINE_RevB.pdf

For soldering reflow profile and reliability test ratings go to: <http://www.pericom.com/assets/sre/reflow.pdf>

For tape and reel information go to: http://www.pericom.com/assets/sre/tr_3225_xo.pdf