

USB Charge Controller IC for Single USB Port

Features

- Manages communication to allow charging to occur
- Provides multiple modes of charging to ensure all of the following specs can be met:
 - DCP mode per USB BC1.0, 1.1, & 1.2 spec
 - YD/T - 1591 charger spec
 - Certain modes available can also support devices using non standard approaches to charges such as Apple products.
- Automatic USB Device Identification Circuit (used to determine charging mode required)
- ±4kV High ESD contact Protection on D+/D- per IEC61000-4-2 specification
- -40°C to + 85°C Operating Temperature Range
- Packaging (Pb-free & Green available):
 - 5-pin SOT23 (T)

Applications

- Laptops, Netbooks
- Universal Charger including iPod ®/ iPhone ® Chargers
- Automotive

Description

USB ports have become the charging connector of choice for the majority of handheld devices such as MP3 players, Mobile phones, MP4 players, DSC, and even tablet/slate type devices.

Although the mechanical connector has converged such that these handheld devices can charge using the same cable, the communication scheme followed by each USB device is different when it comes to setting up a charging link.

Pericom's PI5USB66 solves the multiple communication language problem by supporting all protocols available in the market. Therefore, regardless of what USB device is connected to a charger enabled by Pericom, the USB device will be able to understand the charging setup communication and in turn the USB device will be able to efficiently draw current to charge itself.

Pin Configuration

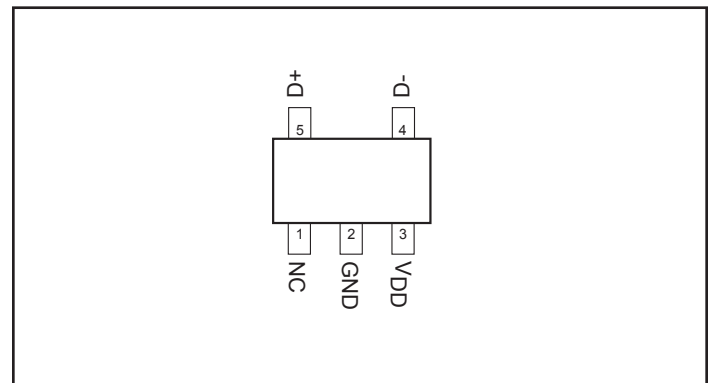

Block Diagram

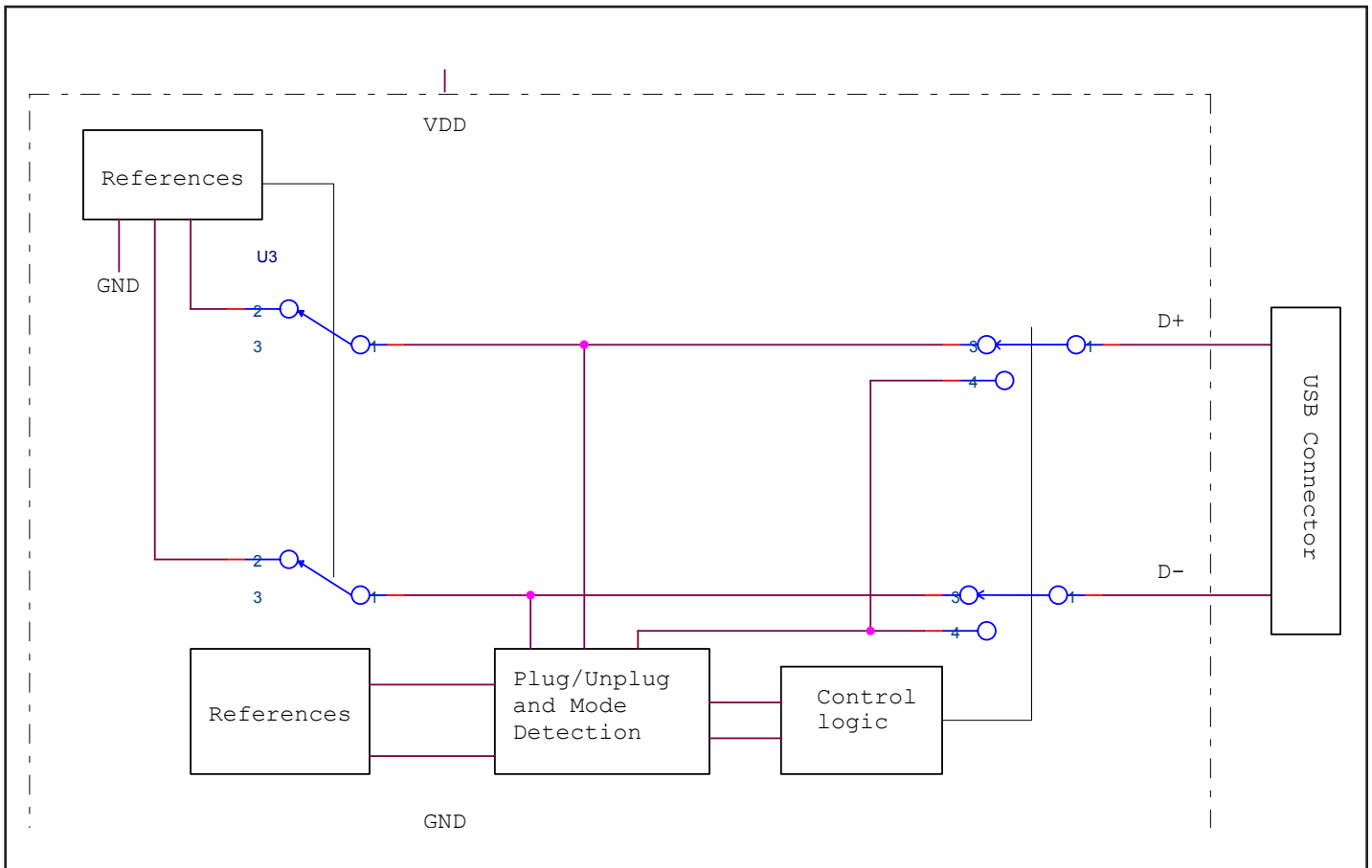
Internal Block Diagram of PI5USB66

Pinout Table

Pin No.	Pin Name	I/O Type	Description
5	D+	I/O	USB connector, D+ Connection
4	D-	I/O	USB connector, D- Connection
3	V _{DD}	Power	5V Power Supply. Connect a 0.1 μ F capacitor between V _{DD} and GND as close as possible to the device
2	GND	Ground	Ground
1	NC		Not connected

USB Charge Controller IC for Single USB Port

Maximum Ratings (Above which the useful life may be impaired. For user guidelines, not tested)

All Inputs and Outputs	-0.5V to $V_{DD} + 0.5V$
Storage temperature.....	-65 to +150°C
Ambient Operating Temperature.....	-40 to +85°C
Supply Voltage to Ground Potential (V_{DD})	+5.5V
Junction Temperature	+150°C
Soldering Temperature (Max of 10 seconds)	+260°C

Note:

Stresses greater than those listed under MAXIMUM RATINGS may cause permanent damage to the device. This is a stress rating only and functional operation of the device at these or any other conditions above those indicated in the operational sections of this specification is not implied. Exposure to absolute maximum rating conditions for extended periods may affect reliability.

Stress beyond those listed under “Absolute Maximum Ratings” may cause permanent damage to the device.

Recommended Operation Conditions

Parameter	Min.	Typ.	Max.	Unit
Ambient Operating Temperature	-40		+85	°C
Power Supply Voltage (measured in respect to GND)	+4.5V		+5.5	V

DC Electrical Characteristics ($V_{DD} = 4.5V$ to $5.5V$, $T_A = T_{MIN}$ to T_{MAX} unless otherwise noted) (Typical Values are at $V_{DD} = 5V$, $T_A = +25°C$)

Symbol	Parameter	Conditions	Min.	Typ.	Max.	Unit
V_{DD}	Operating Voltage		4.5		5.5	V
		$V_{DD} = 4.75V$		280		μA
		$V_{DD} = 5.25V$		310		
ΔI_{CC}	Supply Current Increase				2	
Analog Switch						
V_{D+}, V_{D-}	Analog Signal Range		0		V_{DD}	V
R_{SHORT}	On-Resistance of D+/D- short	$V_{D+} = 1V, I_{D+} = I_{D-} = 10mA$		50	70	Ω
Dynamic Performance						
Internal Resistors						
R_{PD}	D+/D- Short Pulldown		350	500	700	kΩ
R_{TRP}	RP1/RP2 Ratio		1.4	1.5		Ratio
R_{RP}	RP1/RP2 + Resistance		93.7	125.0	156.2	kΩ
R_{TRM}	RM1/RM2 Ratio		0.85	0.86	0.87	Ratio
R_{RM}	RM1/RM2 + Resistance		69.7	93	115.9	kΩ
Comparators						

USB Charge Controller IC for Single USB Port

DC Electrical Characteristics cont.. ($V_{DD} = 4.5V$ to $5.5V$, $T_A = T_{MIN}$ to T_{MAX} unless otherwise noted) (Typical

Values are at $V_{DD} = 5V$, $T_A = +25^{\circ}C$)

Symbol	Parameter	Conditions	Min.	Typ.	Max.	Unit
V_{D-1F}	D-1 Comparator Threshold	D- Falling	45	46	47	% V_{DD}
	D-1 Comparator Hysterisis			1		%
V_{D-2F}	D-2 Comparator Threshold	D- Falling	6.31	7	7.6	% V_{DD}
	D-1 Comparator Hysterisis			1		%
V_{DPR}	D+ Comparator Threshold	D+ Rising	45	46	47	% V_{DD}
	D+ Comparator Hysterisis					
ESD Protection						
V_{ESD}	ESD Protection Level D+ and D- only	Contact (IEC61000-4-2)	± 4			kV
V_{ESD}	ESD Protection Level All other pins	HBM (JESD22)	± 2			kV

Notes:

1. Package Thermal resistance was obtained using the method described in JEDEC specification JESD51-7, using a four layer board
2. Guaranteed by design.

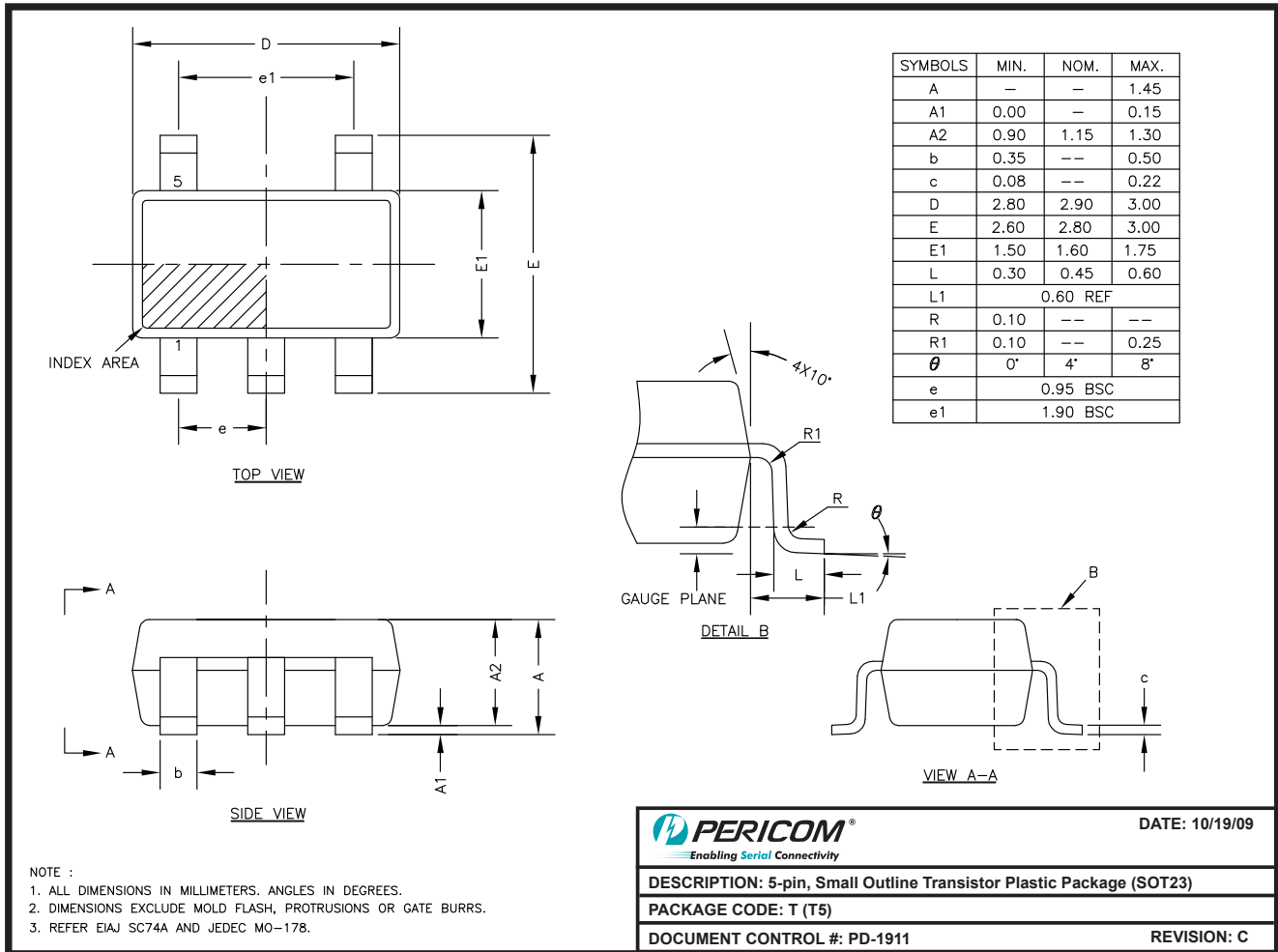

09-0130

Note:

 For latest package info, please check: <http://www.pericom.com/products/packaging/mechanicals.php>
Ordering Information

Ordering Code	Package Code	Package Type	Top Mark
PI5USB66TE	TE	Pb-free & Green, 5pin SOT23	TF

- Thermal characteristics can be found on the company web site at www.pericom.com/packaging/
- E = Pb-free and Green
- Adding an X suffix = Tape/Reel