

SOTiny™ Low Resistance, Low-Voltage Single-Supply SPDT Switch

Features

- CMOS Technology for Bus and Analog Applications
- Low On-Resistance: 8Ω at 3.0V
- Wide V+ Range: 1.65V to 6.0V
- Rail-to-Rail Signal Range
- Fast Transition Speed: 2ns at 5.0V
- High Off Isolation: -63dB @ 10MHz
- Break-Before-Make Switching
- High Bandwidth: 350MHz
- Extended Industrial Temperature Range: -40°C to 85°C
- Packaging (Pb-free and Green):
 - 6-pin Small Compact SC70(C6)
 - 6-pin SOT23 (TA6)

Description

The PI5A4599B is a high-bandwidth, fast single-pole double-throw (SPDT) CMOS switch. It can be used as an analog switch or as a low-delay bus switch. Specified over a wide operating power supply voltage range, 1.65V to 6.0V, the PI5A4599B has a maximum ON resistance of 12-ohms at 1.65V, 9-ohms at 2.3V & 6-ohms at 4.5V.

Break-before-make switching prevents both switches being enabled simultaneously. This eliminates signal disruption during switching.

The control input, IN, is independent of supply voltage.

Applications

- Cell Phones
- PDAs
- MP3 Players
- Portable Instrumentation
- Battery powered Communications
- Computer Peripherals

Pin Assignment

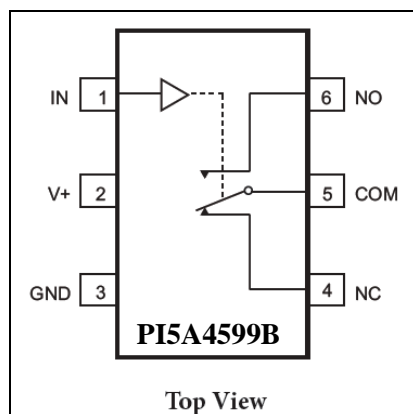

Pin Description

Pin No	Pin Name	Description
1	IN	Logic control
2	V+	Positive Power Supply
3	GND	Ground
4	NC	Data Port (Normally connected)
5	COM	Common Output/Data Port
6	NO	Data Port

Logic Function Table

Logic Inputs(IN)	NC	NO
0	ON	OFF
1	OFF	ON



Maximum Ratings

Storage Temperature.....	-65°C to +150°C
Ambient Temperature with Power Applied.....	-40°C to +85°C
Supply Voltage V+	-0.5V to +7.0V
DC Switch Voltage V _{IN}	-0.5V to V+ +0.5V
DC Input Voltage V _{INPUT}	-0.5V to +7.0V
DC Output Current V _{OUT}	128mA
DC V+ or Ground Current I+ /I _{GND}	±100mA
Junction Temperature under Bias (T _J)	150°C
Junction Lead Temperature (T _L) (Soldering, 10 seconds)	260°C
Power Dissipation (P _d) @ +85°C	180mW

Note:

Stresses greater than those listed under MAXIMUM RATINGS may cause permanent damage to the device. This is a stress rating only and functional operation of the device at these or any other conditions above those indicated in the operational sections of this specification is not implied. Exposure to absolute maximum rating conditions for extended periods may affect reliability.

Recommended Operating Conditions

Symbol	Parameter	Conditions	Min.	Typ.	Max.	Unit
V+	Operating Voltage	-	1.65	-	6.0	V
V _{IN}	Control Input Voltage	-	0	-	V+	V
V _S	Switch Input Voltage	-	0	-	V+	V
V _{OUT}	Output Voltage	-	0	-	V+	V
T _A	Operating Temperature	-	-40	25	85	°C
t _r , t _f	Input Rise and Fall Time	Control Input V+ = 2.3V to 3.6V	0	-	10	ns/V
		Control Input V+ = 4.5V to 6.0V	0	-	5	ns/V

Note: Control input must be held HIGH or LOW; it must not float.

DC Electrical Characteristics

(T_A = -40°C to 85°C, unless otherwise noted.)

Parameter	Description	Test Conditions	Temperature (T _A :°C)	Min	Typ	Max	Units
V _{IAR}	Analog Input Signal Range	V+	-40°C to 85°C	0	-	V+	V
R _{ON}	ON Resistance ⁽¹⁾	V+=4.5V, I _O = 30mA, V _{INPUT} = 0V	25°C	-	4	6	Ω
		V+=4.5V, I _O = -30mA, V _{INPUT} = 2.4V		-	5	8	
		V+=4.5V, I _O = -30mA, V _{INPUT} = 4.5V		-	7	11	
		V+=4.5V, I _O = 30mA, V _{INPUT} = 0V	-40°C to 85°C	-	-	6	
		V+=4.5V, I _O = -30mA, V _{INPUT} = 2.4V		-	-	8	
		V+=4.5V, I _O = -30mA, V _{INPUT} = 4.5V		-	-	11	
		V+=3.0V, I _O = 24mA, V _{INPUT} = 0V	25°C	-	5	8	
		V+=3.0V, I _O = -24mA, V _{INPUT} = 3.0V		-	10	15	
		V+=3.0V, I _O = 24mA, V _{INPUT} = 0V		-40°C to 85°C	-	-	
		V+=3.0V, I _O = -24mA, V _{INPUT} = 3.0V	-		-	15	
		V+=2.3V, I _O = 8mA, V _{INPUT} = 0V	25°C		-	6	
		V+=2.3V, I _O = -8mA, V _{INPUT} = 2.3V		-	13	20	
		V+=2.3V, I _O = 8mA, V _{INPUT} = 0V		-40°C to 85°C	-	-	
		V+=2.3V, I _O = -8mA, V _{INPUT} = 2.3V	-		-	20	
		V+=1.65V, I _O = 4mA, V _{INPUT} = 0V	25°C		-	8	
		V+=1.65V, I _O = -4mA, V _{INPUT} = 1.65V		-	20	30	
		V+=1.65V, I _O = 4mA, V _{INPUT} = 0V		-40°C to 85°C	-	-	
		V+=1.65V, I _O = -4mA, V _{INPUT} = 1.65V	-		-	25	
ΔR _{ON}	ON Resistance Match Between Channels ^(1,2,3)	V+=4.5V, I _A = -30mA, V _{INPUT} = 3.15V	25°C		-	0.15	-
		V+=3.0V, I _A = -24mA, V _{INPUT} = 2.1V		-	0.2	-	
		V+=2.3V, I _A = -8mA, V _{INPUT} = 1.6V		-	0.3	-	
		V+=1.65V, I _A = -4mA, V _{INPUT} = 1.15V		-	0.5	-	
R _{ONF}	ON Resistance Flatness ^(1,2,4)	V+=5.0V, I _A = -30mA, 0 ≤ V _{INPUT} ≤ V+	25°C	-	4.6	-	Ω
		V+=3.3V, I _A = -24mA, 0 ≤ V _{INPUT} ≤ V+		-	7	-	
		V+=2.5V, I _A = -8mA, 0 ≤ V _{INPUT} ≤ V+		-	15	-	
		V+=1.8V, I _A = -4mA, 0 ≤ V _{INPUT} ≤ V+		-	77	-	
V _{IH}	Input High Voltage (Logic High Level)	V+=1.65V	-40°C to 85°C	1	-	-	V
		V+ = 2.3V		1.2	-	-	
		V+ = 3V		1.3	-	-	
		V+ = 4.2V		1.5	-	-	
		V+ = 5.5V		1.8	-	-	
V _{IL}	Input Low Voltage (Logic Low Level)	V+=1.65V	-40°C to 85°C	-	-	0.4	V
		V+ = 2.3V		-	-	0.6	
		V+ = 3V		-	-	0.8	
		V+ = 4.2V		-	-	1	
		V+ = 5.5V		-	-	1.2	
I _{LKC}	Input Leakage Current	0 ≤ V _{IN} ≤ 5.5V, V+ = 0V to 5.5V	25°C	-	-	±0.1	μA
			-40°C to 85°C	-	-	±1.0	
I _{OFF}	OFF State Leakage Current	0 ≤ V _{IN} ≤ 5.5V, V+ = 1.65V to 5.5V	25°C	-	-	±0.1	μA
			-40°C to 85°C	-	-	±10	
I+	Quiescent Supply Current	All channels ON or OFF, V _{IN} = V+ or GND, I _{OUT} = 0, V+ = 5.5V V	25°C	-	-	1	μA
			-40°C to 85°C	-	-	5	

Notes:

1. Measured by voltage drop between COM and NC/NO pins at the indicated current through the device. ON resistance is determined by the lower of the voltages on two ports (COM or NC/NO).
2. Parameter is characterized but not tested in production.
3. ΔR_{ON} = R_{ON} max – R_{ON} min. measured at identical V+, temperature and voltage levels.
4. Flatness is defined as difference between maximum and minimum value of ON resistance over the specified range of conditions. Guaranteed by design.

Capacitance⁽¹⁾

 (T_A = 25°C, unless otherwise noted.)

Symbol	Parameter	Test Conditions	Min.	Typ.	Max.	Units
C _{IN}	Control Input	V ₊ = 5.0V, f = 1 MHz ⁽¹⁾	-	2.5	-	pF
C _{OFF}	NC/NO Port, Switch OFF		-	5.0	-	
C _{COM ON}	COM Port, Switch ON		-	15.0	-	

Notes:

1. Capacitance is characterized but not tested in production

Switch and AC Characteristics⁽¹⁾

Parameter	Description	Test Conditions	Supply Voltage	Temperature (T _A : °C)	Min	Typ	Max	Units
t _{ON}	Turn-On Time	R _L =100Ω, C _L =35pF, See Test Circuit Figure 1.	V ₊ = 3.3V, V _{NO} or V _{NO} =1.5V, V _{IL} =1.5V,	+25°C	-	5	25	ns
			V ₊ = 5.0V, V _{NO} or V _{NO} =3V, V _{IL} =3V,		-	3	15	
t _{OFF}	Turn-Off Time	R _L =100Ω, C _L =35pF, See Test Circuit Figure 1.	V ₊ = 3.3V, V _{NO} or V _{NO} =1.5V, V _{IL} =1.5V,	+25°C	-	2	12	ns
			V ₊ = 5.0V, V _{NO} or V _{NO} =3V, V _{IL} =3V,		-	1.5	7	
t _{BM}	Break Before Make Time	See Test Circuit Figure 2.	V ₊ = 1.65V to 1.95V	-40 to 85°C	0.5	-	-	ns
			V ₊ = 2.3V to 2.7V		0.5	-	-	
			V ₊ = 3.0V to 3.6V		0.5	-	-	
			V ₊ = 4.5V to 5.5V		0.5	-	-	
Q	Charge Injection	C _L = 0.1nF, V _{GEN} = 0V, R _{GEN} =0Ω. See Test Circuit Figure 3.	V ₊ = 5.0V	25°C	-	5	-	pC
			V ₊ = 3.3V		-	4	-	
OIRR	Off Isolation	R _L =50Ω, V _{GEN} =0V, R _{GEN} =0Ω, f=1MHz. See test circuit 5 ⁽³⁾	V ₊ = 1.65V to 5.5V	25°C	-	-82	-	dB
X _{TALK}	Crosstalk Isolation	R _L =50Ω, V _{GEN} =0V, R _{GEN} =0Ω, f=1MHz.	V ₊ = 1.65V to 5.5V	25°C	-	-82	-	
f _{3dB}	-3dB Bandwidth	See Test Circuit Figure 8	V ₊ = 1.65V to 5.5V	25°C	-	350	-	MHz

Notes:

1. Guaranteed by design.
2. The device contributes no other propagation delay other than the RC delay of the switch ON resistance and the 50pF load capacitance, when driven by an ideal voltage source with zero output impedance.
3. Off Isolation = 20 Log₁₀ [V_{NC} (or V_{NO})/V_{COM}] and is measured in dB.
4. Crosstalk Isolation = 20 Log₁₀ [V_{NO}/V_{NC}] and is measured in dB.

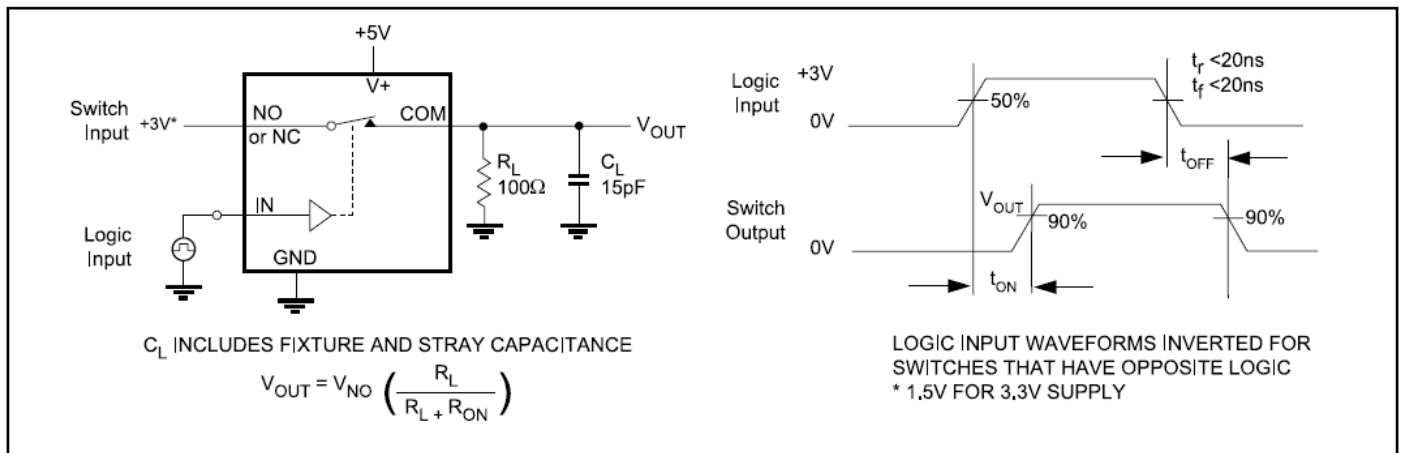
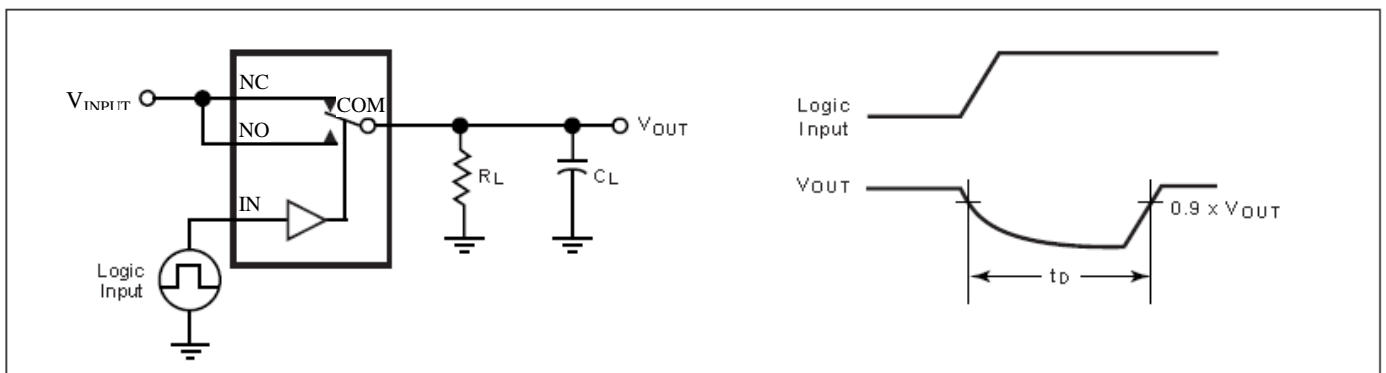
Test Circuits and Timing Diagrams

Figure 1. Switching Time

Figure 2. Break Before Make Interval Timing

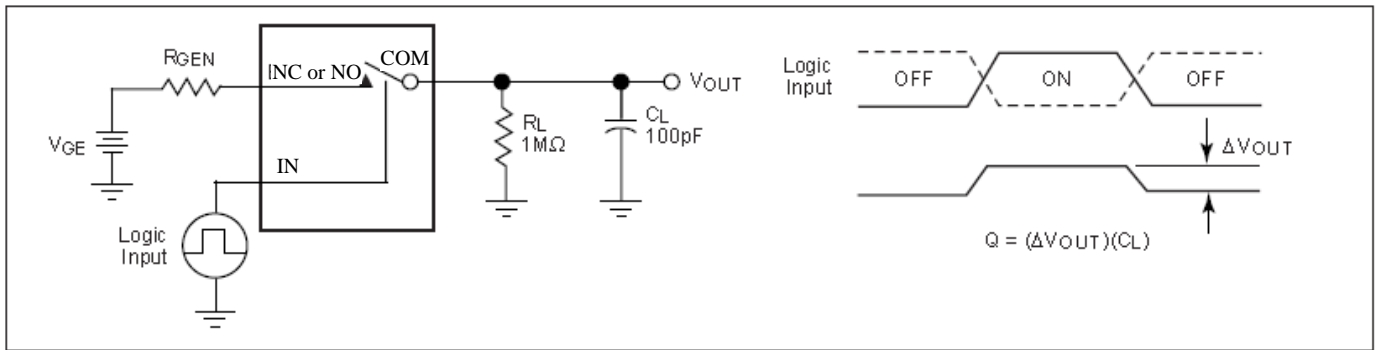

Figure 3. Charge Injection Test

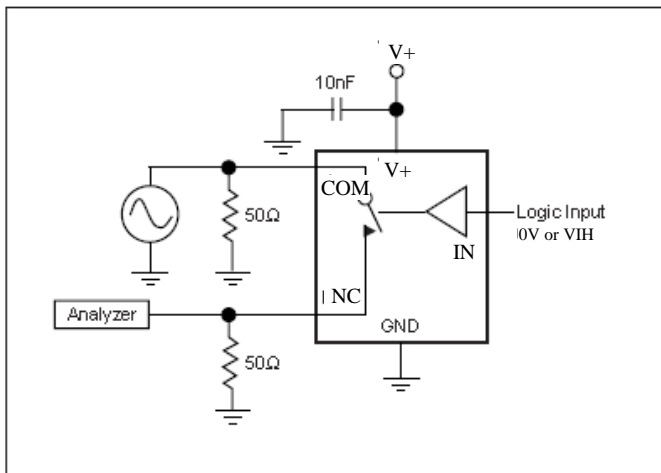

Figure 4. Off Isolation

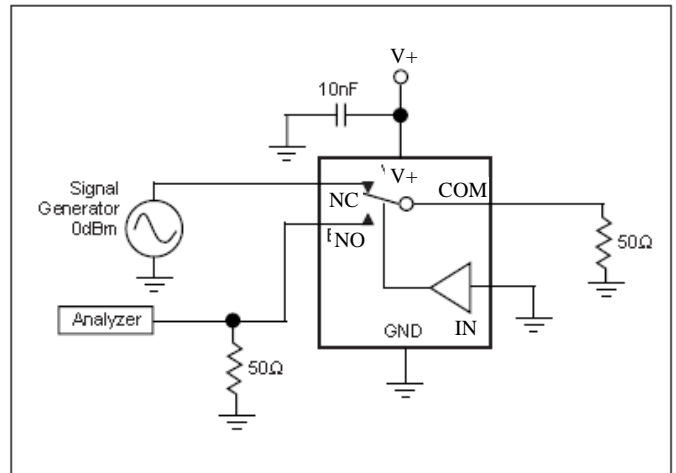

Figure 5. Crosstalk

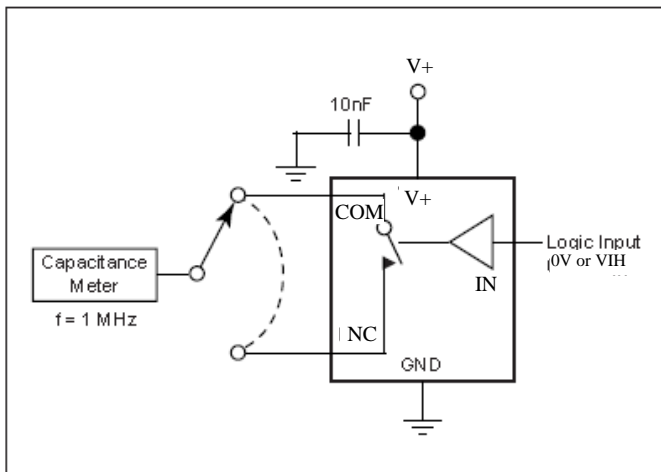

Figure 6. Channel Off Capacitance

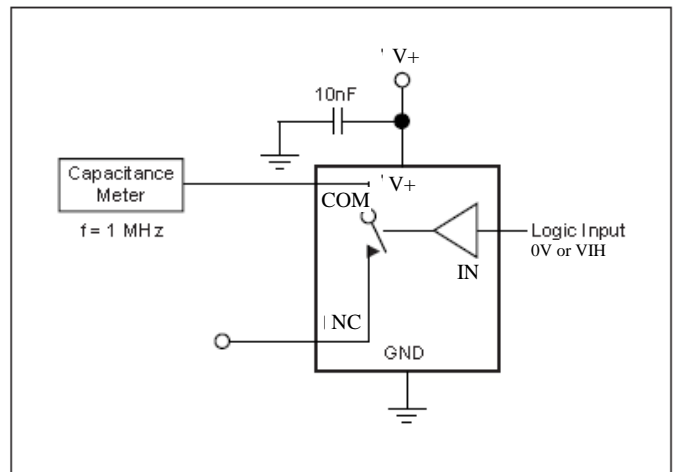

Figure 7. Channel On Capacitance

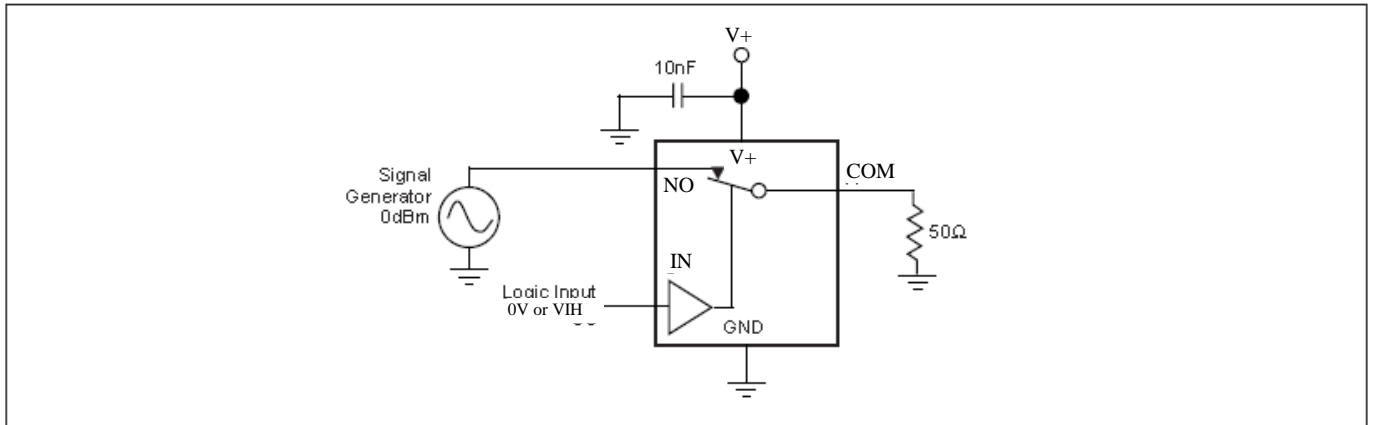
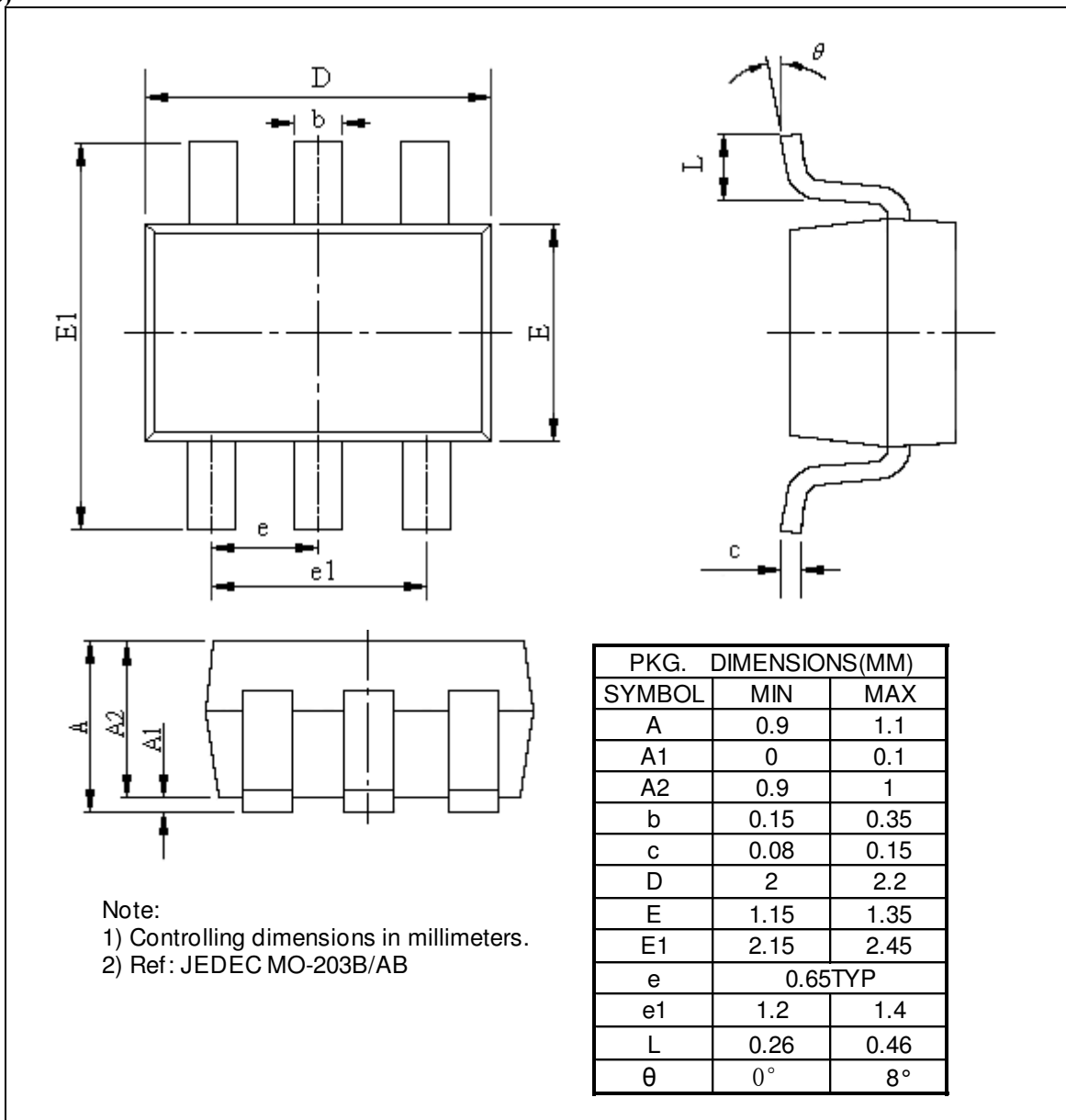

Figure 8. Bandwidth

Mechanical Information

C (SC70-6)



TA (SOT23-6)

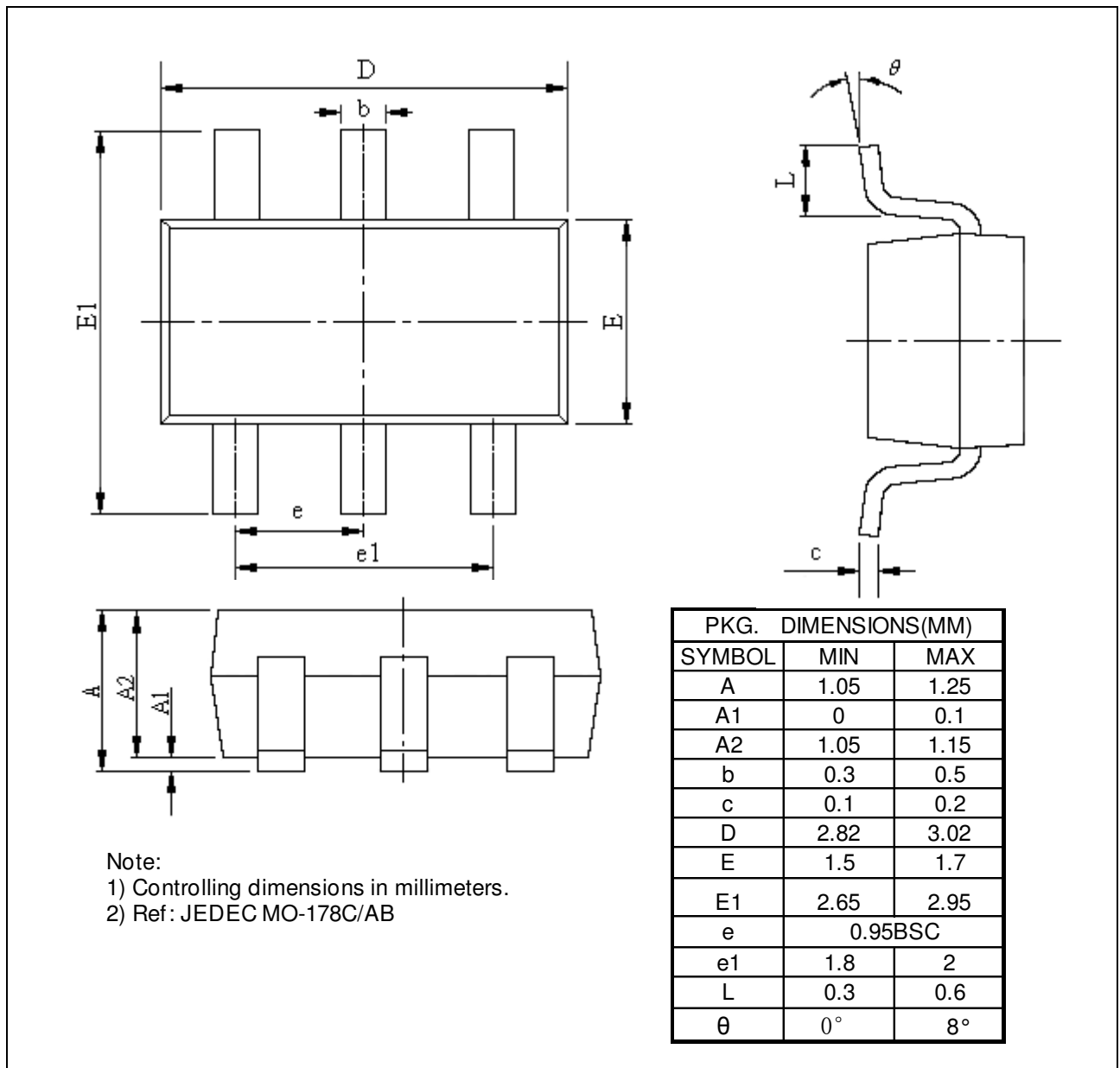

Ordering Information

Part Number	Package Code	Package	Top Marking
PI5A4599BCE	C	Lead Free and Green SC70-6 (C)	nK
PI5A4599BTAE	TA	Lead Free and Green SOT23-6 (TA)	nK

Notes:

- E = Pb-free and Green
- Adding X Suffix= Tape/Reel

 Pericom Semiconductor Corporation • 1-800-435-2336 • www.pericom.com

Pericom reserves the right to make changes to its products or specifications at any time, without notice, in order to improve design or performance and to supply the best possible product. Pericom does not assume any responsibility for use of any circuitry described other than the circuitry embodied in Pericom product. The company makes no representations that circuitry described herein is free from patent infringement or other rights, of Pericom.