

## Low Voltage SPST 0.8Ω Analog Switch

### Features

- CMOS Technology for Bus and Analog Applications
- Low On-Resistance: 0.8Ω at 3.0V
- Wide V<sub>CC</sub> Range: 1.65V to 5.5V
- Rail-to-Rail Signal Range
- Control Input Overvoltage Tolerance: 5.5V
- Fast Transition Speed: 2ns at 5.0V
- High Bandwidth: 200MHz
- Extended Industrial Temperature Range: -40°C to 85°C
- I/O pins Has Power-off Protection Function
- Packaging (Pb-free & Green):
  - 5-pin SOT23
  - 5-pin SC70

### Applications

- Cell Phones
- PDAs
- Portable Instrumentation
- Battery powered Communications
- Computer Peripherals

### Description

The PI5A3166 is a high-bandwidth, fast single-pole single-throw (SPST) CMOS switch. It can be used as an analog switch or as a low-delay bus switch. The device features ultra low RON of 0.8Ω typical at 3.0V V<sub>CC</sub> and will operate over the wide V<sub>CC</sub> range of 1.65V to 5.5V.

The PI5A3166 features very low quiescent current even when the control voltage is lower than the V<sub>CC</sub> supply. This feature services the mobile handset applications very well by allowing direct interface with baseband processor general purpose I/Os.

The control input, S, is independent of supply voltage.

### Pin Assignment

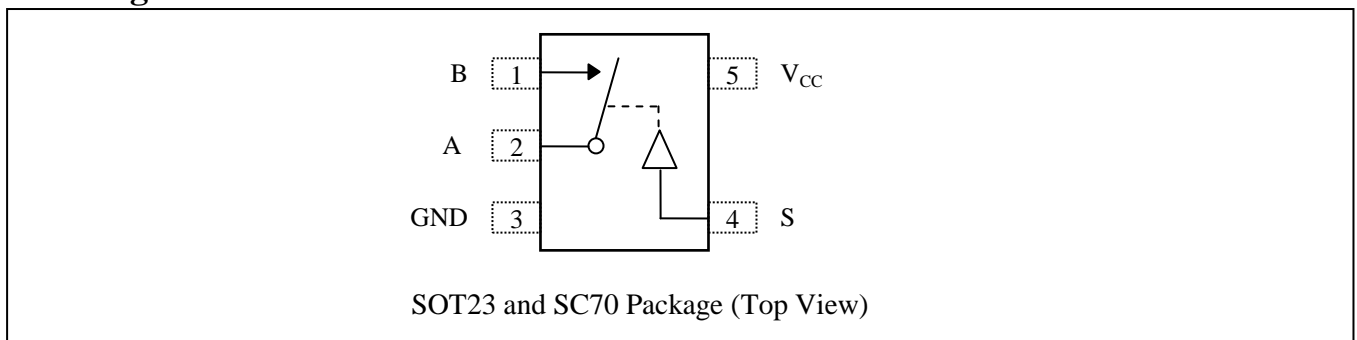

### Pin Description

Pin No	Pin Name	Description
1	B	Data Port
2	A	Common Output/Data Port
3	GND	Ground
4	S	Logic Control
5	VCC	Positive Power Supply

### Logic Function Table

Logic Input(S)	Function(A to B)
0	OFF
1	ON

### Maximum Ratings

Storage Temperature.....	-65°C to +150°C
Ambient Temperature with Power Applied.....	-40°C to +85°C
Supply Voltage $V_{CC}$ .....	-0.5V to +7.0V
DC Switch Voltage $V_S$ .....	-0.5V to +7.0V
DC Input Voltage $V_{IN}$ .....	-0.5V to +7.0V
DC Output Current $V_{OUT}$ .....	128mA
DC $V_{CC}$ or Ground Current $I_{CC} / I_{GND}$ .....	±100mA
Junction Temperature under Bias ( $T_J$ ).....	150°C
Junction Lead Temperature ( $T_L$ ) (Soldering, 10 seconds).....	260°C
ESD (HBM).....	4KV
Power Dissipation (PD) @ +85°C.....	SOT23 250mW SC70 200mW

**Note:**

Stresses greater than those listed under MAXIMUM RATINGS may cause permanent damage to the device. This is a stress rating only and functional operation of the device at these or any other conditions above those indicated in the operational sections of this specification is not implied. Exposure to absolute maximum rating conditions for extended periods may affect reliability.

### Recommended Operating Conditions

Symbol	Parameter	Conditions	Min.	Typ.	Max.	Unit
$V_{CC}$	Operating Voltage	-	1.65	-	5.5	V
$V_{IN}$	DC Input Voltage	-	0	-	$V_{CC}$	V
$V_S$	Switch Input Voltage	-	0	-	5.5	V
$V_{OUT}$	Output Voltage	-	0	-	$V_{CC}$	V
$T_A$	Operating Temperature	-	-40	25	85	°C
$t_r, t_f$	Input Rise and Fall Time	Control Input $V_{CC} = 2.7V$ to $3.6V$	0	-	10	ns/V
		Control Input $V_{CC} = 4.5V$ to $5.5V$	0	-	5	ns/V

**Note:** Control input must be held HIGH or LOW; it must not float.

**DC Electrical Characteristics**

 (T<sub>A</sub> = -40°C to 85°C, unless otherwise noted.)

Parameter	Description	Test Conditions	Supply Voltage	Min	Typ	Max	Units
V <sub>IAR</sub>	Analog Input Signal Range	-	V <sub>CC</sub>	0	-	V <sub>CC</sub>	V
R <sub>ON</sub>	ON Resistance <sup>(1)</sup>	I <sub>A</sub> = 100mA, V <sub>B</sub> = 0V	4.5V	-	0.7	1.0	Ω
		I <sub>A</sub> = 100mA, V <sub>B</sub> = 2.4V		-	0.6	0.9	
		I <sub>A</sub> = 100mA, V <sub>B</sub> = 4.5V		-	0.8	1.1	
		I <sub>A</sub> = 100mA, V <sub>B</sub> = 0V	3.0V	-	0.8	1.2	
		I <sub>A</sub> = 100mA, V <sub>B</sub> = 3.0V		-	0.9	1.8	
		I <sub>A</sub> = 100mA, V <sub>B</sub> = 0V	2.3V	-	1.0	1.3	
		I <sub>A</sub> = 100mA, V <sub>B</sub> = 2.3V		-	1.2	1.7	
		I <sub>A</sub> = 100mA, V <sub>B</sub> = 0V		1.65V	-	1.3	
I <sub>A</sub> = 100mA, V <sub>B</sub> = 1.65V	-	2.0	2.6				
R <sub>ONF</sub>	ON Resistance Flatness <sup>(2)</sup>	I <sub>A</sub> = 100mA, V <sub>B</sub> = 0V, 2.4V, 4.5V	4.5V	-	0.2	0.4	Ω
		I <sub>A</sub> = 100mA, V <sub>B</sub> = 0V, 1.5V, 3.3V	3.3V	-	0.2	0.4	
		I <sub>A</sub> = 100mA, V <sub>B</sub> = 0V, 1.1V, 2.5V	2.5V	-	0.4	0.6	
		I <sub>A</sub> = 100mA, V <sub>B</sub> = 0V, 0.7V, 1.8V	1.8V	-	1.0	1.4	
V <sub>IH</sub>	Input High Voltage	Logic High Level	V <sub>CC</sub> = 1.65V	1	-	-	V
			V <sub>CC</sub> = 2.3V	1.2	-	-	
			V <sub>CC</sub> = 3V	1.3	-	-	
			V <sub>CC</sub> = 4.2V	1.5	-	-	
			V <sub>CC</sub> = 5.5V	1.8	-	-	
V <sub>IL</sub>	Input Low Voltage	Logic Low Level	V <sub>CC</sub> = 1.65V	-	-	0.4	V
			V <sub>CC</sub> = 2.3V	-	-	0.6	
			V <sub>CC</sub> = 3V	-	-	0.8	
			V <sub>CC</sub> = 4.2V	-	-	1	
			V <sub>CC</sub> = 5.5V	-	-	1.2	
I <sub>OFF(B)</sub>	Source Off Leakage Current	V <sub>CC</sub> =5.5V, V <sub>A</sub> =1V, 4.5V V <sub>B</sub> =1V, 4.5V	V <sub>CC</sub> = 3V	-20	-	+20	nA
I <sub>INC(A, B)</sub>	Channel On Leakage Current	-	V <sub>CC</sub> = 1.65 to 5.5V	-40	-	+40	
I <sub>PWROFF</sub>	Input Leakage Current for Power off	0 ≤ V <sub>A</sub> ≤ 5.5V 0 ≤ V <sub>B</sub> ≤ 5.5V	V <sub>CC</sub> = 0V	-5	-	5	μA
I <sub>CC</sub>	Quiescent Supply Current	All channels ON or OFF, V <sub>B</sub> = V <sub>CC</sub> or GND, I <sub>OUT</sub> =0	V <sub>CC</sub> = 3.6V	-	0.002	0.1	μA
			V <sub>CC</sub> = 5.5V	-	0.002	0.1	

**Notes:**

- Measured by voltage drop between A and B pins at the indicated current through the device. ON resistance is determined by the lower of the voltages on two ports (A or B).
- Flatness is defined as difference between maximum and minimum value of ON resistance over the specified range of conditions. Guaranteed by design.

**Capacitance<sup>(1)</sup>**

Symbol	Parameter	Test Conditions	Min.	Typ.	Max.	Units
C <sub>IN</sub>	Control Input	V <sub>CC</sub> = 5.0V, f = 1 MHz, T <sub>A</sub> = 25°C	-	3.5	-	pF
C <sub>IO-B</sub>	For B Port, Switch OFF		-	15.0	-	
C <sub>IOA-ON</sub>	For A Port, Switch ON		-	34.0	-	

**Notes:**

- Capacitance is characterized but not tested in production

**Switch and AC Characteristics <sup>(1)</sup>**

Parameter	Description	Test Conditions	Supply Voltage	Min	Typ	Max	Units
$t_{ON}$	Turn on Time	See Figure 1	$V_{CC} = 2.7V$ to $3.6V$	-	3	-	ns
			$V_{CC} = 4.5V$ to $5.5V$	-	2	-	
$t_{OFF}$	Turn off Time	See Figure 1	$V_{CC} = 2.7V$ to $3.6V$	-	9	-	
			$V_{CC} = 4.5V$ to $5.5V$	-	5	-	
Q	Charge Injection	$C_L = 1nF$ , $V_{GEN} = 0V$ , $R_{GEN} = 0\Omega$ . See Figure 2	$V_{CC} = 5.0V$	-	35	-	pC
			$V_{CC} = 3.3V$	-	25	-	
$O_{IRR}$	Off Isolation	$R_L = 50\Omega$ , $V_{GEN} = 0V$ , $R_{GEN} = 0\Omega$ , $f = 1MHz$ . See Figure 3 <sup>(2)</sup>	$V_{CC} = 1.65V$ to $5.5V$	-	-70	-	dB
f <sub>3dB</sub>	-3dB Bandwidth	See Figure 6	$V_{CC} = 1.65V$ to $5.5V$	-	200	-	MHz
$T_{HD}$	Total Harmonic Distortion	$R_L = 600\Omega$ , $V_{IN} = 0.5V_{pp}$ , $f = 20Hz$ to $20kHz$ See Figure 7	$V_{CC} = 2.7V$ to $4.2V$	-	0.015	-	%

**Notes:**

1. Guaranteed by design.
2. Off Isolation =  $20 \text{ Log}_{10}[V_B/V_A]$  and is measured in dB.

**Test Circuits and Timing Diagrams**

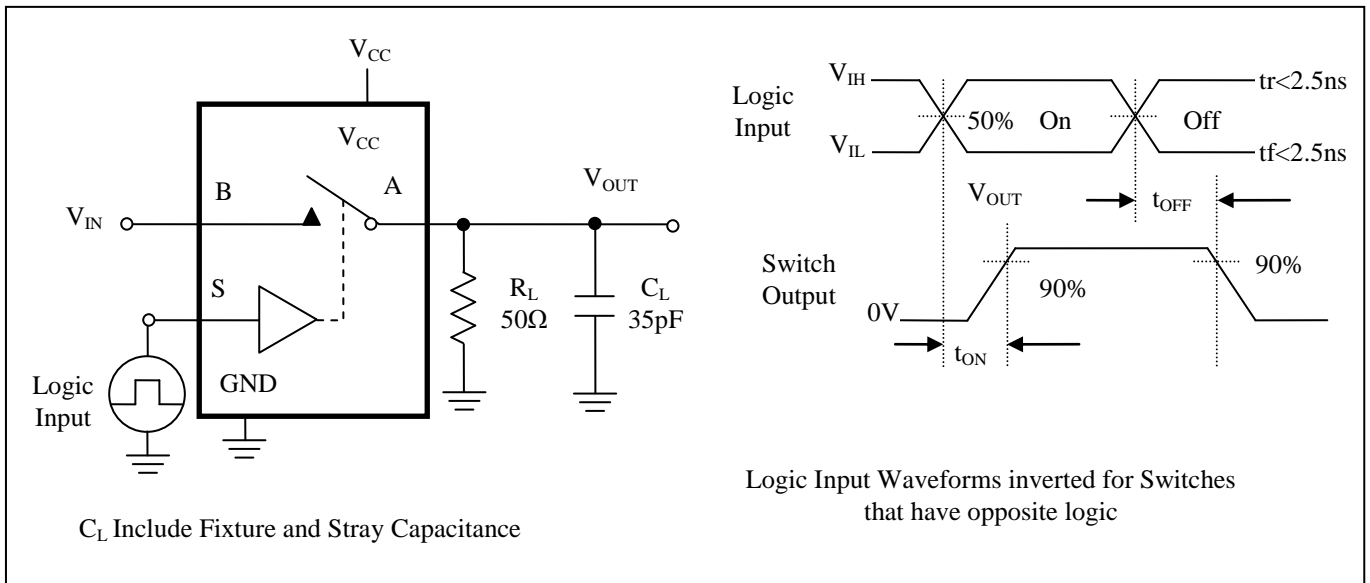

**Figure 1. Turn ON/OFF Timing**

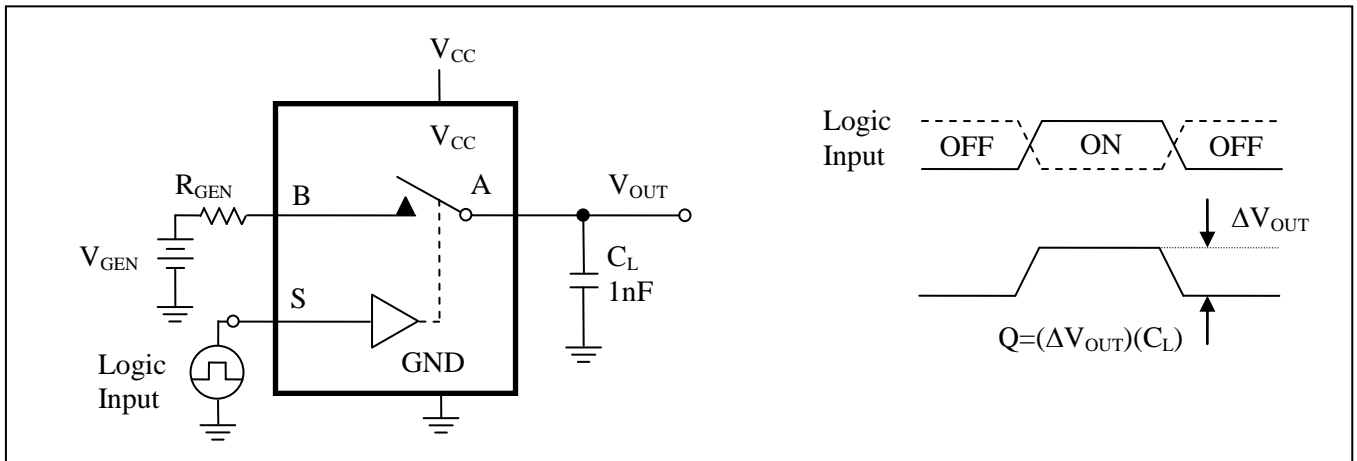

**Figure 2. Charge Injection Test**

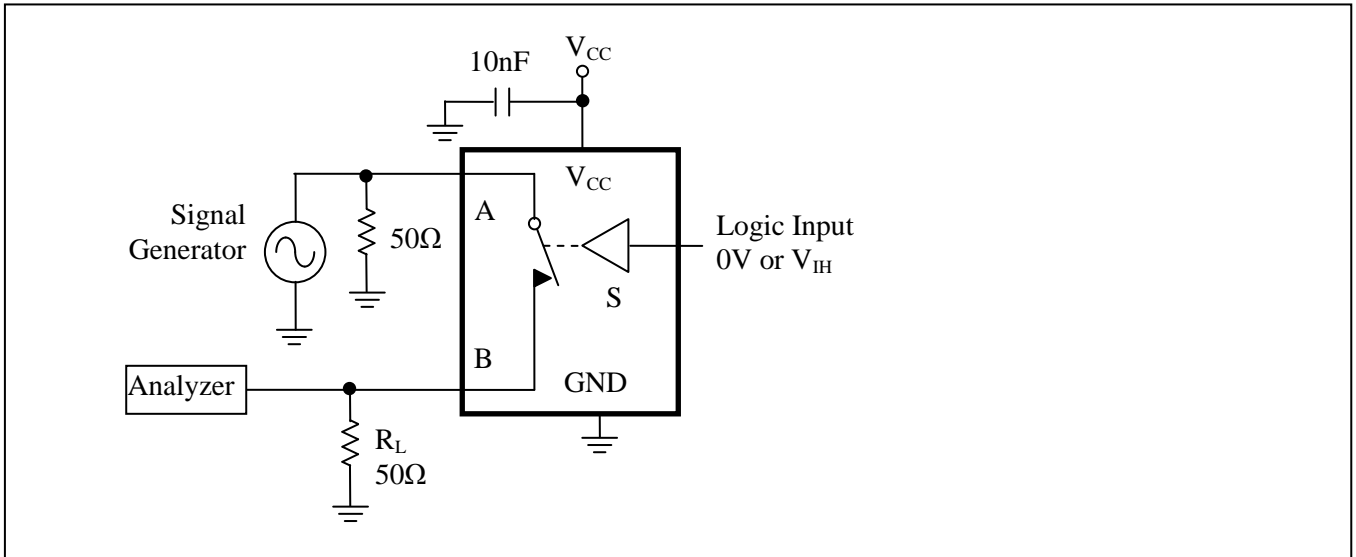

**Figure 3. Off Isolation**

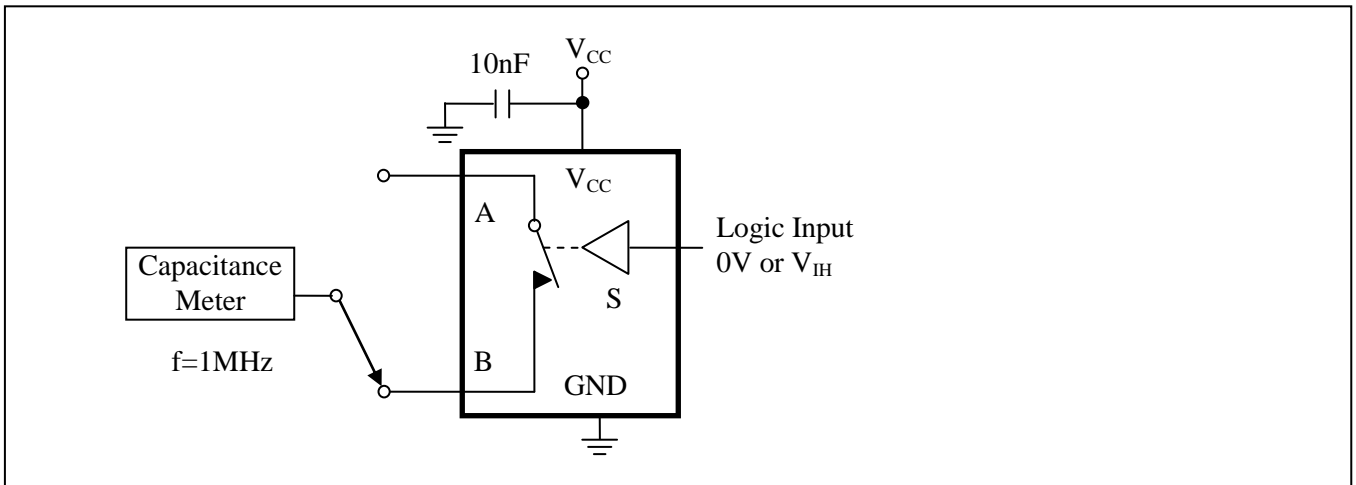

**Figure 4. Channel Off Capacitance**

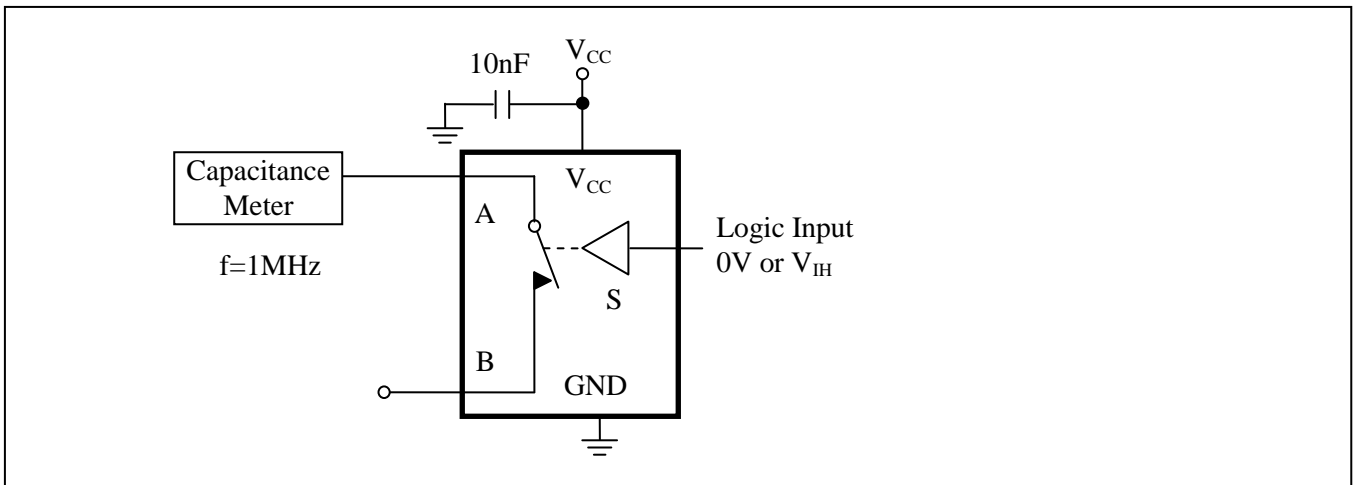

**Figure 5. Channel On Capacitance**

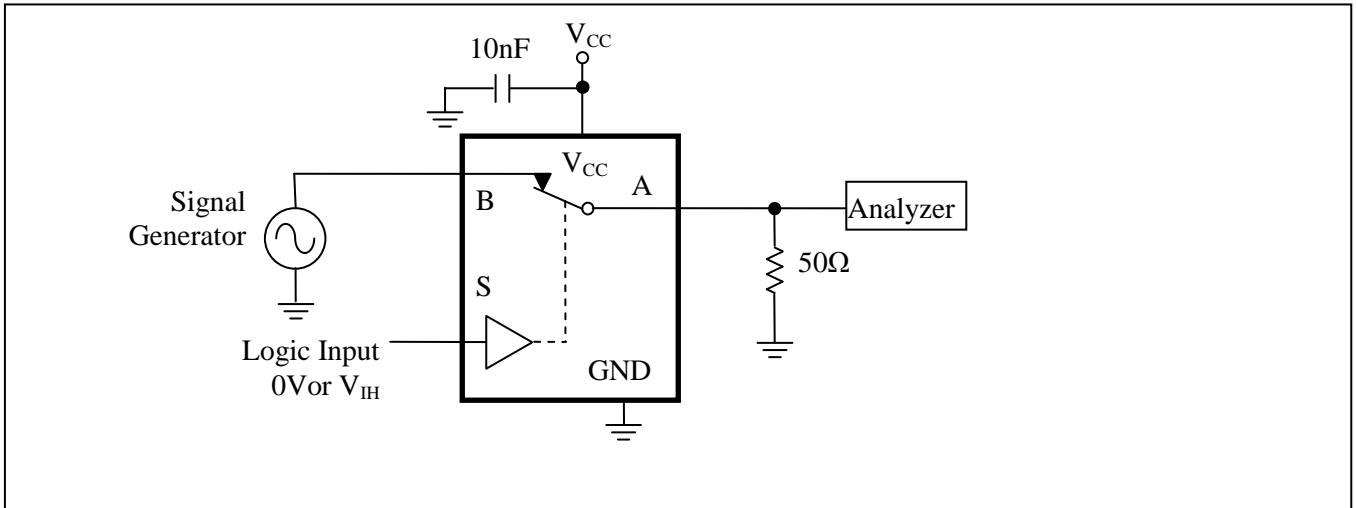

**Figure 6. Bandwidth**

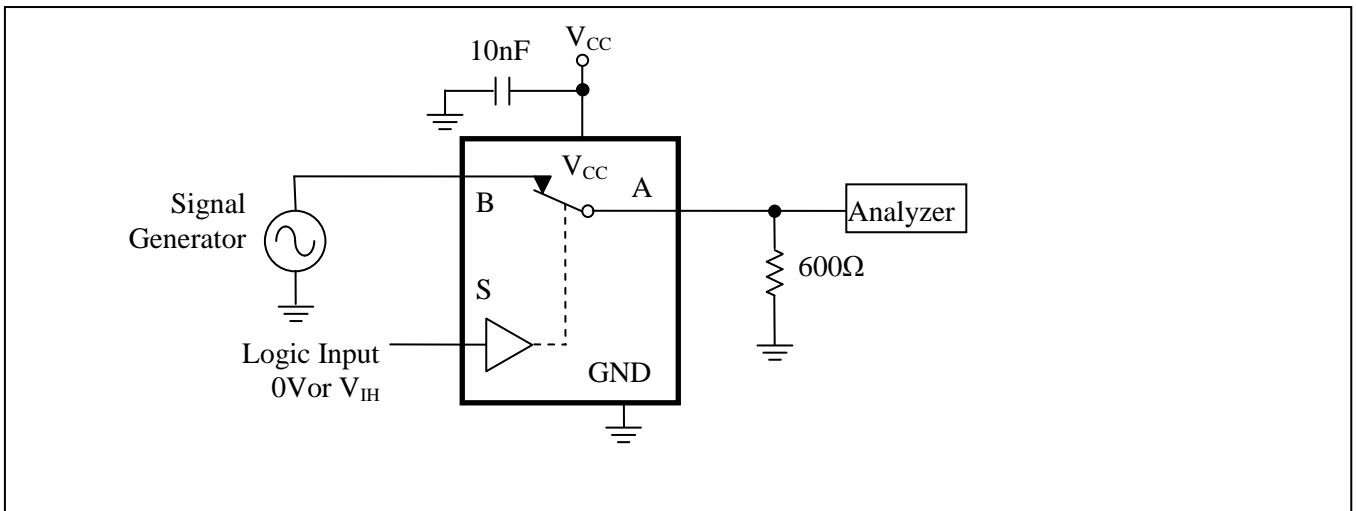

**Figure 7. Harmonic Distortion**

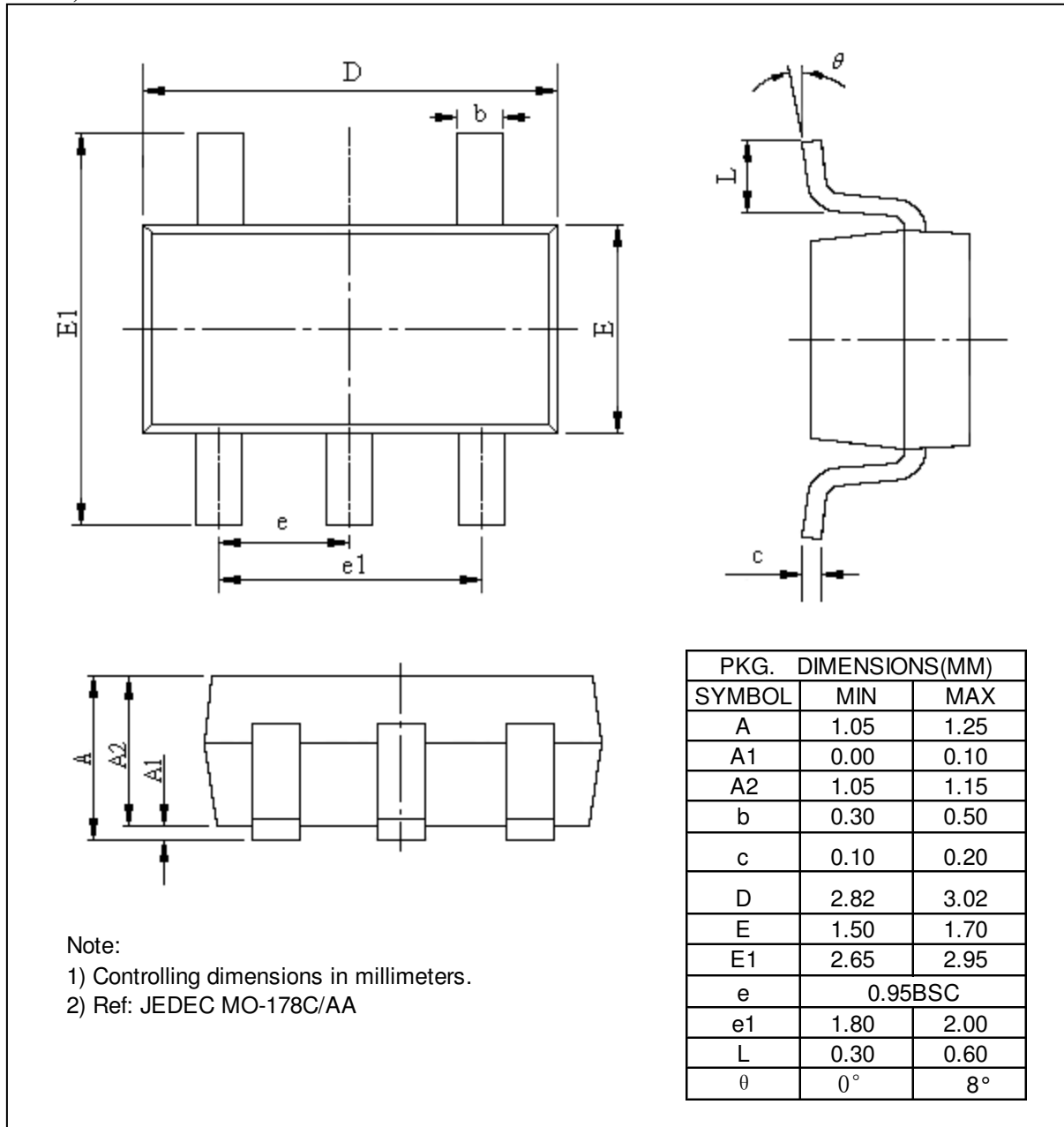
**Mechanical Information**
**TAE (SOT23-5)**

CE (SC70-5)

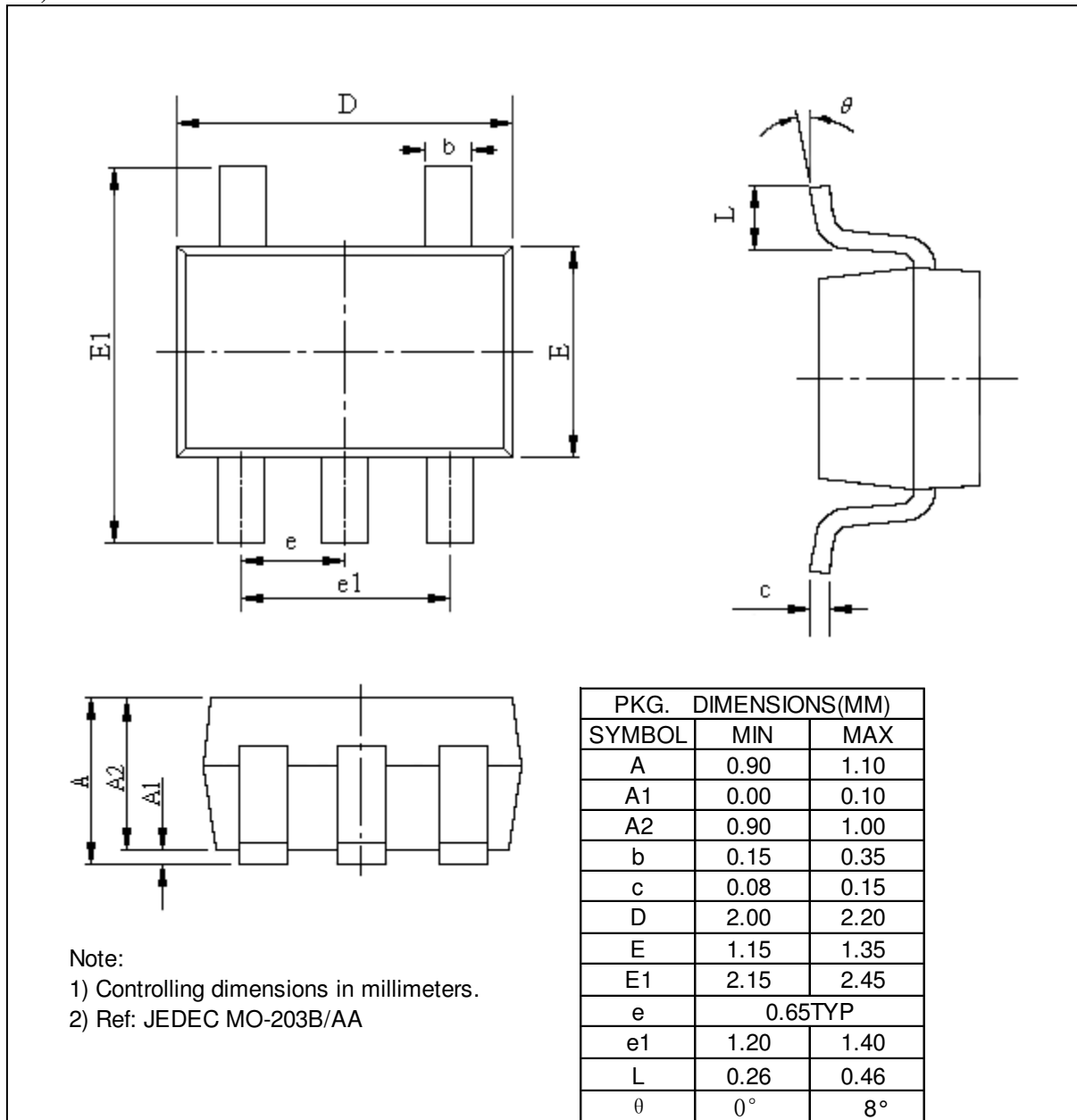

## Ordering Information

Part Number	Package Code	Package	Top Marking
PI5A3166CE	C	Lead Free and Green SC70-5 (C)	pP
PI5A3166TAE	TA	Lead Free and Green SOT23-5 (TA)	pP

### Notes:

- E = Pb-free and Green
- Adding X Suffix= Tape/Reel