

Dual SPST Wide Bandwidth Analog Switch

Features

- CMOS Technology for Bus and Analog Applications
- Low On-Resistance: 8Ω at 3.0V
- Wide V_{CC} Range: 1.65V to 6.0V
- Rail-to-Rail Signal Range
- Control Input Overvoltage Tolerance: 6.0V
- Fast Transition Speed: 2ns at 5.0V
- High Off Isolation: -63dB @ 10MHz
- Extended Industrial Temperature Range: -40°C to 85°C
- Packaging (Pb-free & Green):
-8-pin TDFN 2x3

Applications

- Audio, Video Switching, and Routing
- Cell Phones
- PDAs
- Telecommunications
- Portable Instrumentation
- Battery powered Communication Systems
- Computer Peripherals
- Mechanical Relay Replacement

Description

The PI5A221B is a dual single-pole single throw (D-SPST) normally open CMOS switch. The switch is open when IN is LOW. The high-precision device is ideal for low-distortion audio, video, signal switching and routing. Specified over a wide operating power supply voltage, 1.65V to 6.0V, the PI5A221B has on-resistance of 12-ohms at 1.65V, 9-ohms at 2.3V & 6-ohms at 4.5V.

The control input, IN, is independent of supply voltage.

Pin Assignment

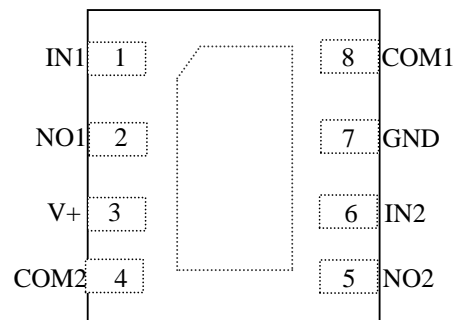

Pin Description

Pin No	Pin Name	Description
1,6	INx	Logic Control
2,5	COM1,COM2	Common Output/Data Port
3	V+	Positive Power Supply
4,8	NO1, NO2	Data Port
7	GND	Ground

Logic Function Table

Logic Inputs(IN)	Function
0	OFF
1	ON



Maximum Ratings

Storage Temperature.....	-65°C to +150°C
Ambient Temperature with Power Applied.....	-40°C to +85°C
Supply Voltage V_+	-0.3V to +7.0V
DC Control Voltage V_{IN}	-0.5V to 7.0V
DC Input Voltage (V_{NO} , V_{COM}).....	-0.3V to $V_+ + 0.5V$
DC Output Current I_{OUT}	128mA
DC V_+ or Ground Current I_+ / I_{GND}	$\pm 100mA$
Junction Temperature under Bias (T_J)	150°C
Junction Lead Temperature (T_L) (Soldering, 10 seconds)	260°C
Power Dissipation (P_d) @ +85°C	180mW
ESD (HBM).....	2000V

Note:

Stresses greater than those listed under MAXIMUM RATINGS may cause permanent damage to the device. This is a stress rating only and functional operation of the device at these or any other conditions above those indicated in the operational sections of this specification is not implied. Exposure to absolute maximum rating conditions for extended periods may affect reliability.

Recommended Operating Conditions

Symbol	Parameter	Conditions	Min.	Typ.	Max.	Unit
V_+	Operating Voltage	-	1.65	-	6.0	V
V_{IN}	Control Input Voltage	-	0	-	6.0	V
V_{INPUT}	Switch Input Voltage	-	0	-	V_+	V
V_{OUT}	Output Voltage	-	0	-	V_+	V
T_A	Operating Temperature	-	-40	25	85	°C
t_r , t_f	Control Input Rise and Fall Time	$V_+ = 2.3V$ to $3.6V$	0	-	10	ns/V
		$V_+ = 4.5V$ to $6.0V$	0	-	5	ns/V

Note: Control input must be held HIGH or LOW; it must not float.



DC Electrical Characteristics

($T_A = -40^\circ\text{C}$ to 85°C , unless otherwise noted.)

Parameter	Description	Test Conditions	Temperature	Min	Typ	Max	Units
V_{IAR}	Analog Input Signal Range	V+	-40°C to 85°C	0	-	6	V
R_{ON}	ON Resistance ⁽¹⁾	V+=4.5V, $I_O = 30\text{mA}$, $V_{INPUT} = 0\text{V}$	25°C	-	4	6	Ω
		V+=4.5V, $I_O = -30\text{mA}$, $V_{INPUT} = 2.4\text{V}$		-	5	8	
		V+=4.5V, $I_O = -30\text{mA}$, $V_{INPUT} = 4.5\text{V}$		-	7	11	
		V+=4.5V, $I_O = 30\text{mA}$, $V_{INPUT} = 0\text{V}$	-40°C to 85°C	-	-	6	
		V+=4.5V, $I_O = -30\text{mA}$, $V_{INPUT} = 2.4\text{V}$		-	-	8	
		V+=4.5V, $I_O = -30\text{mA}$, $V_{INPUT} = 4.5\text{V}$		-	-	11	
		V+=3.0V, $I_O = 24\text{mA}$, $V_{INPUT} = 0\text{V}$	25°C	-	5	8	
		V+=3.0V, $I_O = -24\text{mA}$, $V_{INPUT} = 3.0\text{V}$		-	10	15	
		V+=3.0V, $I_O = 24\text{mA}$, $V_{INPUT} = 0\text{V}$		-	-	8	
		V+=3.0V, $I_O = -24\text{mA}$, $V_{INPUT} = 3.0\text{V}$	-40°C to 85°C	-	-	15	
		V+=2.3V, $I_O = 8\text{mA}$, $V_{INPUT} = 0\text{V}$		-	6	9	
		V+=2.3V, $I_O = -8\text{mA}$, $V_{INPUT} = 2.3\text{V}$		-	13	20	
		V+=2.3V, $I_O = 8\text{mA}$, $V_{INPUT} = 0\text{V}$	25°C	-	-	9	
		V+=2.3V, $I_O = -8\text{mA}$, $V_{INPUT} = 2.3\text{V}$		-	-	20	
		V+=1.65V, $I_O = 4\text{mA}$, $V_{INPUT} = 0\text{V}$		-	8	12	
		V+=1.65V, $I_O = -4\text{mA}$, $V_{INPUT} = 1.65\text{V}$	25°C	-	20	30	
		V+=1.65V, $I_O = 4\text{mA}$, $V_{INPUT} = 0\text{V}$		-	-	12	
		V+=1.65V, $I_O = -4\text{mA}$, $V_{INPUT} = 1.65\text{V}$		-	-	30	
R_{ONF}	ON Resistance Flatness ^(1,2,3)	V+=5.0V, $I_A = -30\text{mA}$, $0 \leq V_{INPUT} \leq V+$	25°C	-	6	-	Ω
		V+=3.3V, $I_A = -24\text{mA}$, $0 \leq V_{INPUT} \leq V+$		-	12	-	
		V+=2.5V, $I_A = -8\text{mA}$, $0 \leq V_{INPUT} \leq V+$		-	22	-	
		V+=1.8V, $I_A = -4\text{mA}$, $0 \leq V_{INPUT} \leq V+$		-	90	-	
V_{IH}	Input High Voltage (Logic High Level)	V+=1.65V	-40°C to 85°C	1	-	-	V
		V+ = 2.3V		1.2	-	-	
		V+ = 3V		1.3	-	-	
		V+ = 4.2V		1.5	-	-	
		V+ = 6.0V		1.8	-	-	
V_{IL}	Input Low Voltage (Logic Low Level)	V+=1.65V	-40°C to 85°C	-	-	0.4	V
		V+ = 2.3V		-	-	0.6	
		V+ = 3V		-	-	0.8	
		V+ = 4.2V		-	-	1	
		V+ = 6.0V		-	-	1.2	
I_{LKC}	Input Leakage Current	$0 \leq V_{IN} \leq 6.0\text{V}$, $V+ = 0\text{V}$ to 6.0V	25°C	-	-	± 0.1	μA
			-40°C to 85°C	-	-	± 1.0	
I_{OFF}	OFF State Leakage Current	$0 \leq V_{IN} \leq 6.0\text{V}$, $V+ = 1.65\text{V}$ to 6.0V	25°C	-	-	± 0.1	μA
			-40°C to 85°C	-	-	± 10	
I+	Quiescent Supply Current	All channels ON or OFF, $V_{IN} = V+$ or GND, $I_{OUT} = 0$, $V+ = 6.0\text{V}$	25°C	-	-	1	μA
			-40°C to 85°C	-	-	5	

Notes:

1. Measured by voltage drop between COM and NO pins at the indicated current through the device. ON resistance is determined by the lower of the voltages on two ports (COM or NO).
2. Parameter is characterized but not tested in production.
3. Flatness is defined as difference between maximum and minimum value of ON resistance over the specified range of conditions. Guaranteed by design.

Capacitance⁽¹⁾

 (T_A = 25°C, unless otherwise noted.)

Symbol	Parameter	Test Conditions	Min.	Typ.	Max.	Units
C _{IN}	Control Input	V ₊ = 5.0V, f = 1 MHz ⁽¹⁾	-	2.5	-	pF
C _{OFF}	NO Port, Switch OFF		-	5.0	-	
C _{COM ON}	COM Port, Switch ON		-	15.0	-	

Notes:

1. Capacitance is characterized but not tested in production

Switch and AC Characteristics⁽¹⁾

Parameter	Description	Test Conditions	Supply Voltage	Temperature	Min	Typ	Max	Units
t _{ON}	Turn-On Time	R _L =100Ω, C _L =35pF ⁽²⁾ , See Test Circuit Figure 1.	V ₊ = 3.3V, V _{NO} =3.0V, V _{IH} =3.0V, V ₊ = 5.0V, V _{NO} =3V, V _{IL} =3V,	-40~+85°C	-	3.6	6	ns
t _{OFF}	Turn-Off Time	R _L =100Ω, C _L =35pF, See Test Circuit Figure 1.	V ₊ = 3.3V, V _{NO} =3.0V, V _{IH} =3.0V, V ₊ = 5.0V, V _{NO} =3V, V _{IL} =3V,	-40~+85°C	-	3	5	ns
Q	Charge Injection	C _L = 1nF, V _{GEN} = 0V, R _{GEN} =0Ω. See Test Circuit Figure 2.	V ₊ = 5.0V V ₊ = 3.3V	25°C	-	5	-	pC
f _{3dB}	-3dB Bandwidth	See Test Circuit Figure 5.	V ₊ = 1.65V to 5.5V	25°C	-	500	-	MHz
OIRR	Off Isolation	R _L =50Ω, V _{GEN} =0V, R _{GEN} =0Ω, f=10MHz. See Test Circuit Figure 6	V ₊ = 1.65V to 5.5V	25°C	-	-63	-	dB

Notes:

1. Guaranteed by design.
2. The device contributes no other propagation delay other than the RC delay of the switch ON resistance and the 35pF load capacitance, when driven by an ideal voltage source with zero output impedance.

Test Circuits and Timing Diagrams

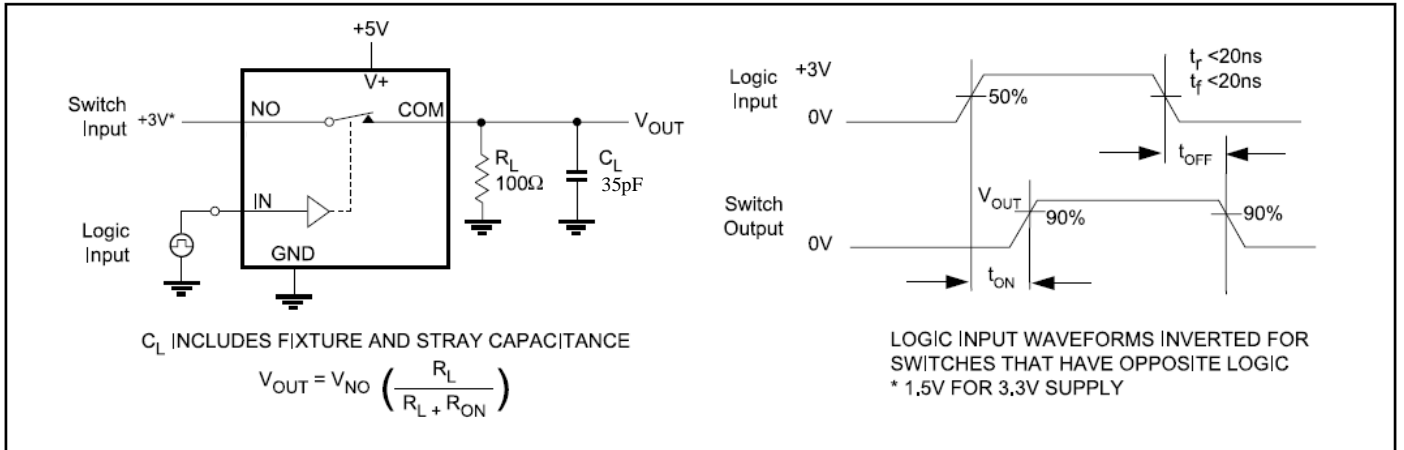

Figure 1. Switching Time

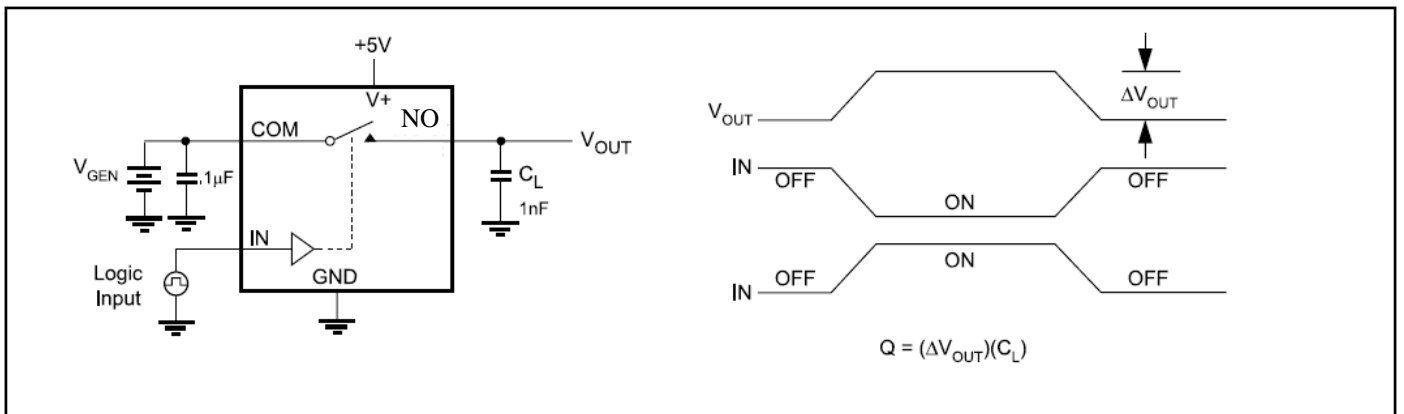

Figure 2. Charge Injection

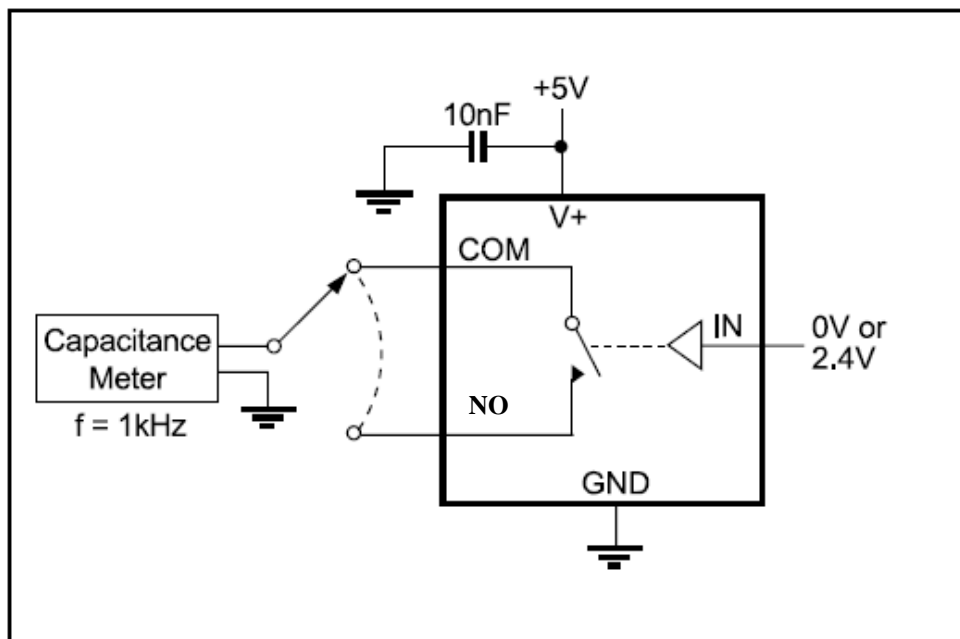

Figure 3. Channel-Off Capacitance

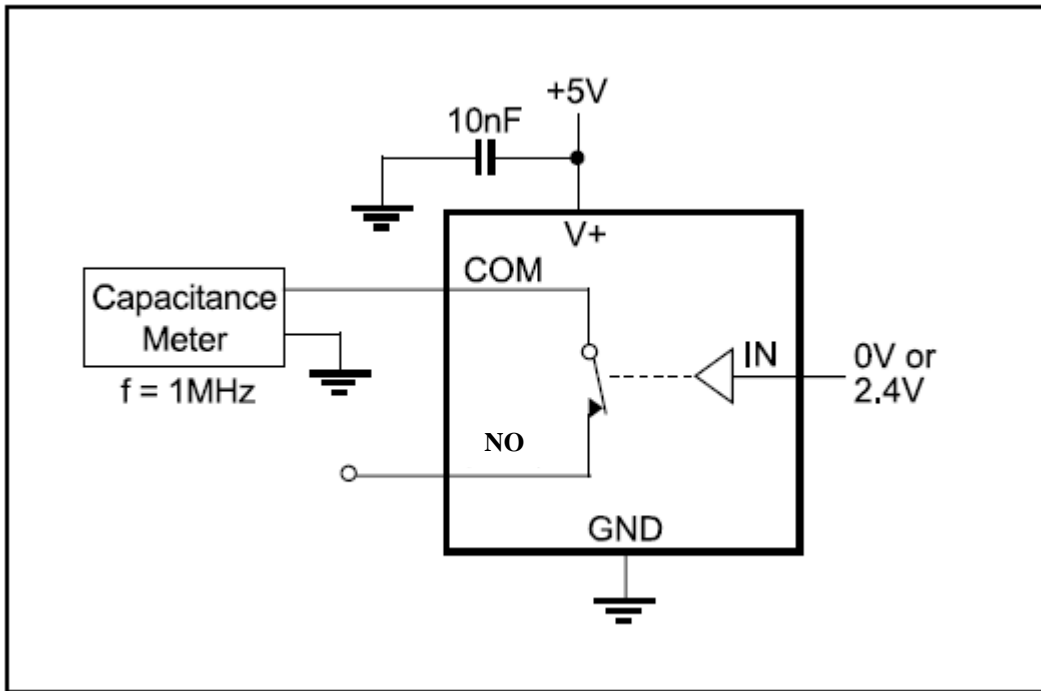

Figure 4. Channel-On Capacitance

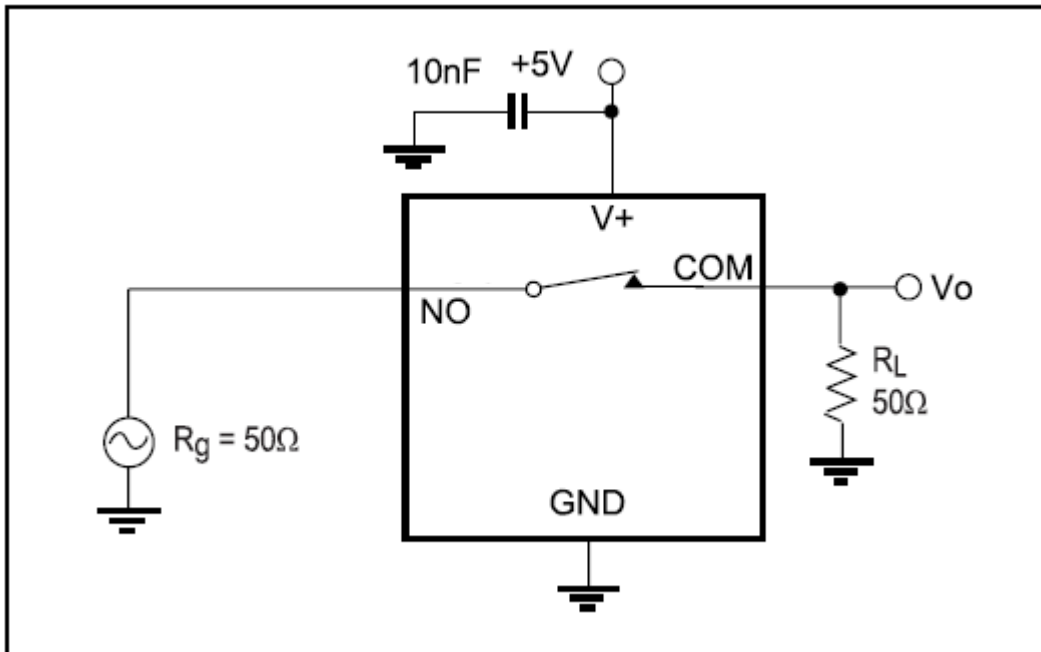

Figure 5. Bandwidth

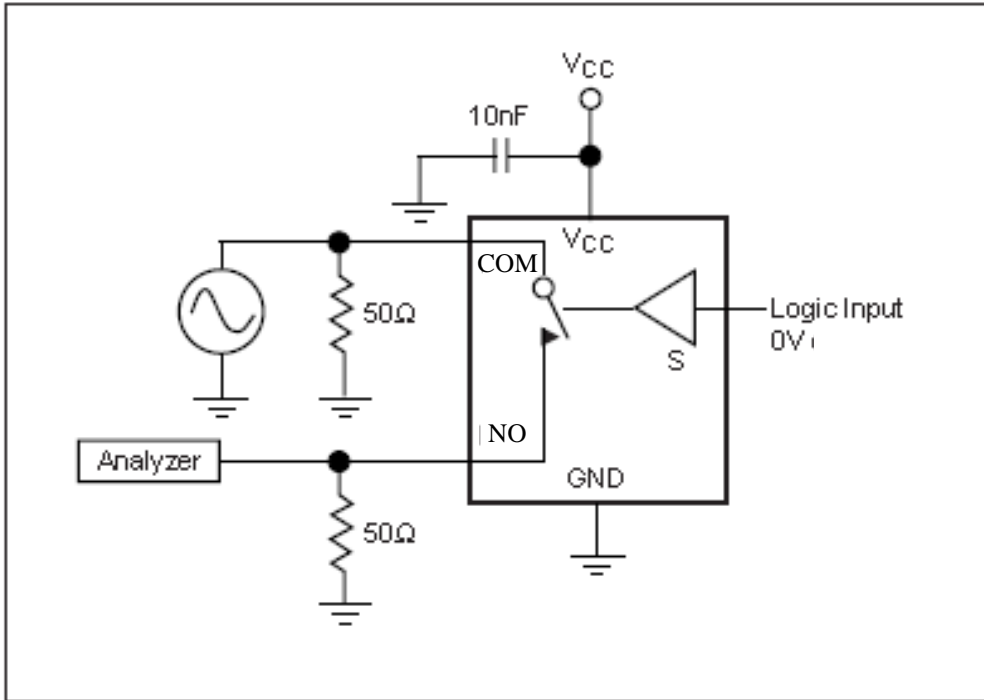
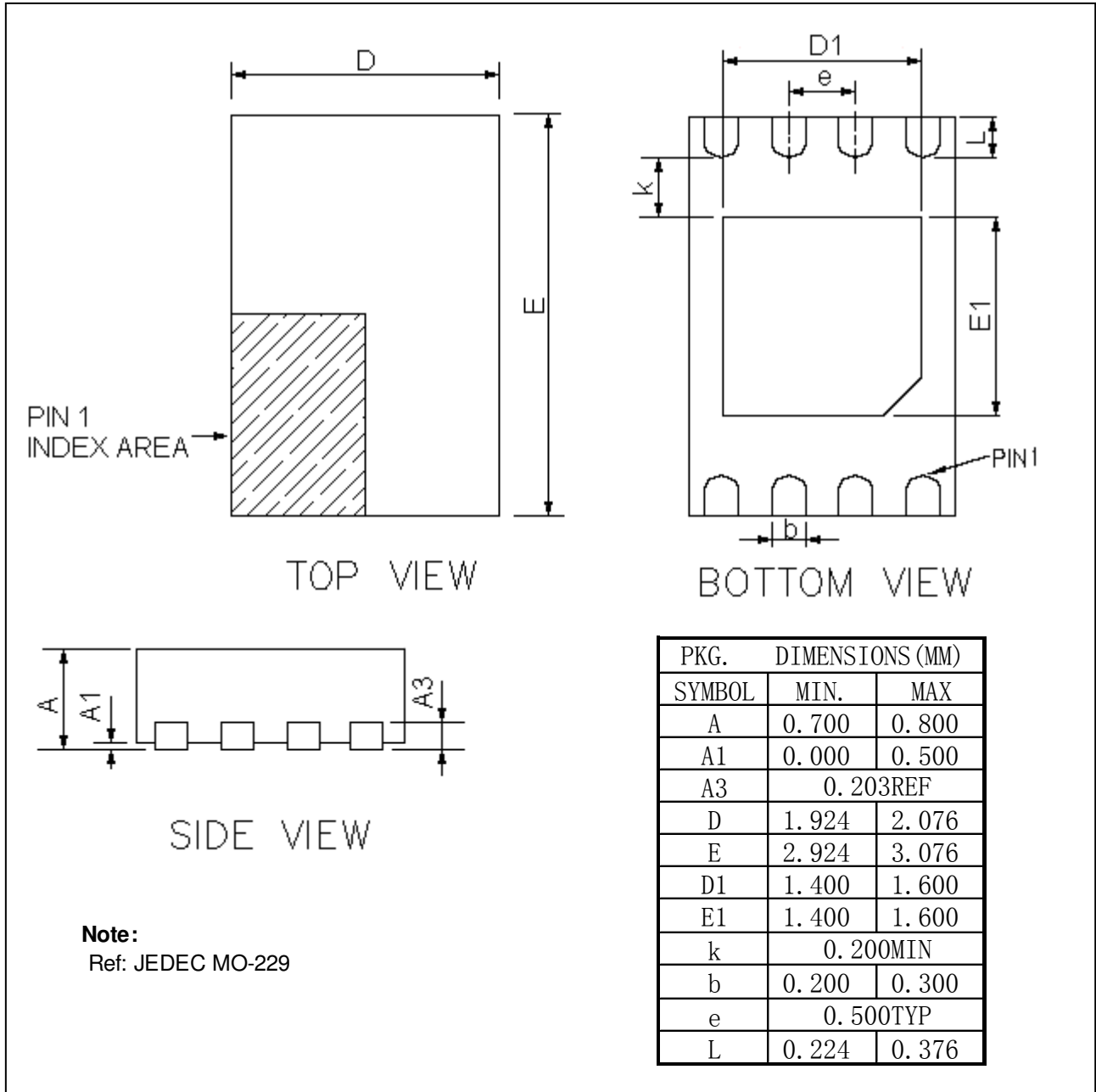

Figure 6. Off Isolation



Mechanical Information

8-pin TDFN 2x3



Marking Description

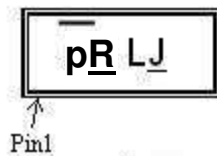



Ordering Information

Part Number	Package Code	Package	Top Marking
PI5A221BZEE	ZE	Lead Free and Green TDFN 2x3 -8L (ZE)	pR

Notes:

- E = Pb-free and Green
- Adding X Suffix= Tape/Reel

Pericom Semiconductor Corporation • 1-800-435-2336 • www.pericom.com

Pericom reserves the right to make changes to its products or specifications at any time, without notice, in order to improve design or performance and to supply the best possible product. Pericom does not assume any responsibility for use of any circuitry described other than the circuitry embodied in Pericom product. The company makes no representations that circuitry described herein is free from patent infringement or other rights, of Pericom.