

2-Lane DisplayPort™ Rev 1.2 Compliant Switch

Features

- 2-lane, 1:2 mux/demux that will support RBR, HBR1, or HBR2
- 1-channel 1:2 mux/demux for DP_HPDP signal
- 1-differential channel 1:2 mux/demux for DP_Aux signal with support up to 720Mbps
- Insertion Loss for high speed channels @ 2.7 GHz: -1.7dB
- -3dB Bandwidth for high speed channels: 4.7GHz
- Return loss for high speed channels @ 2.7GHz: -16dB
- Low Bit-to-Bit Skew , 7ps max (between '+' and '-' bits)
- Low Crosstalk for high speed channels: -25dB@5.4 Gbps
- Low Off Isolation for high speed channels: -25dB@5.4 Gbps
- V_{DD} Operating Range: 3.3V +/-10%
- ESD Tolerance: 2kV HBM
- Low channel-to-channel skew, 35ps max
- Packaging (Pb-free & Green):
 - 32 TQFN (ZL)

Description

Pericom Semiconductor's PI3VDP3212 mux/demux is targeted for next generation digital video signals. This device can be used to connect a DisplayPort™ Source to two Independent DisplayPort Sinks or to connect two DisplayPort sources to a single DP display.

The newly released DisplayPort spec requires a data rate of 5.4 Gbps. Pericom's solution has been specifically designed around this standard and will support such signals.

Application

Routing of DisplayPort signals with low signal attenuation between source and sink.

Block Diagram

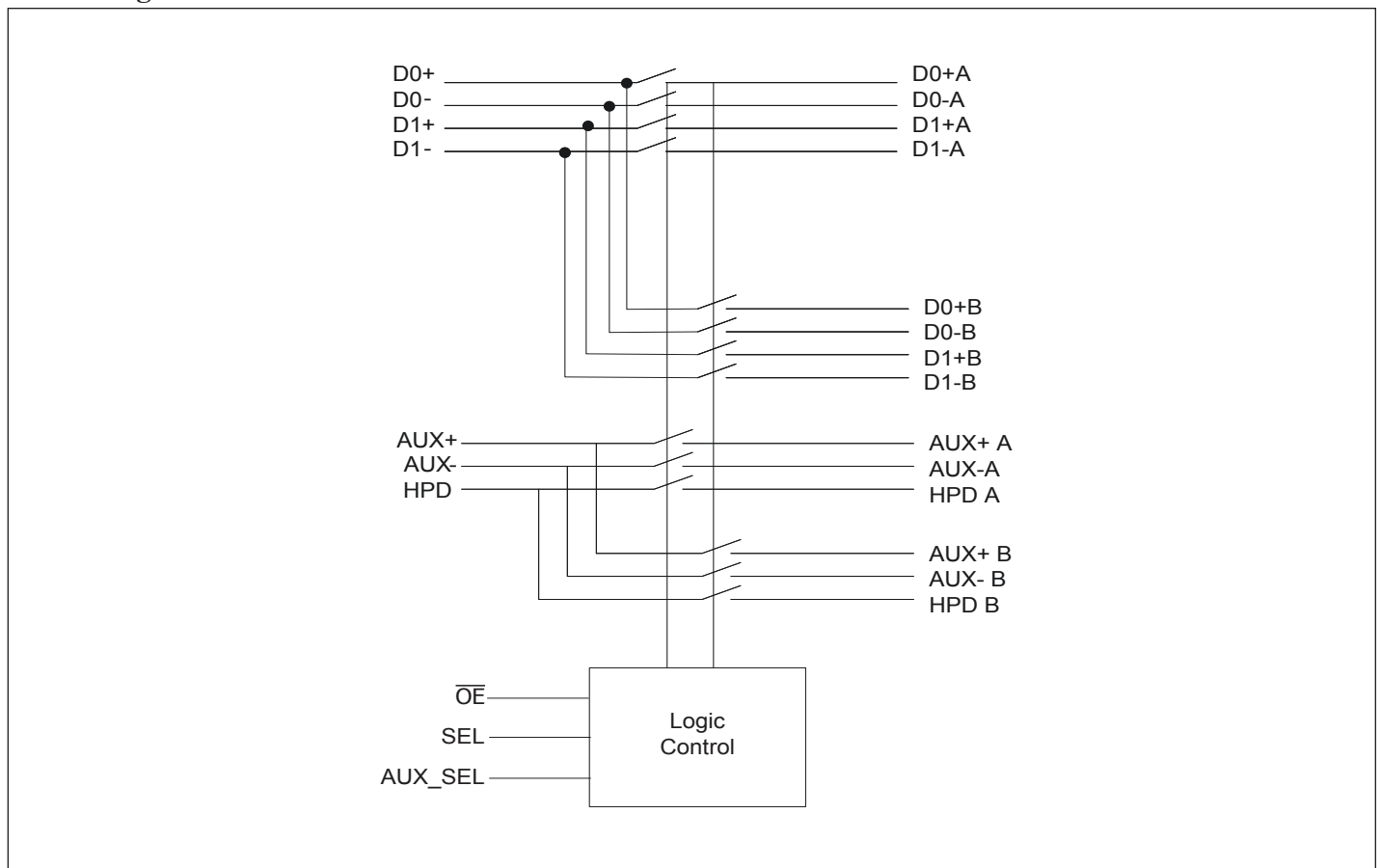

Pin Assignment (TQFN-32)

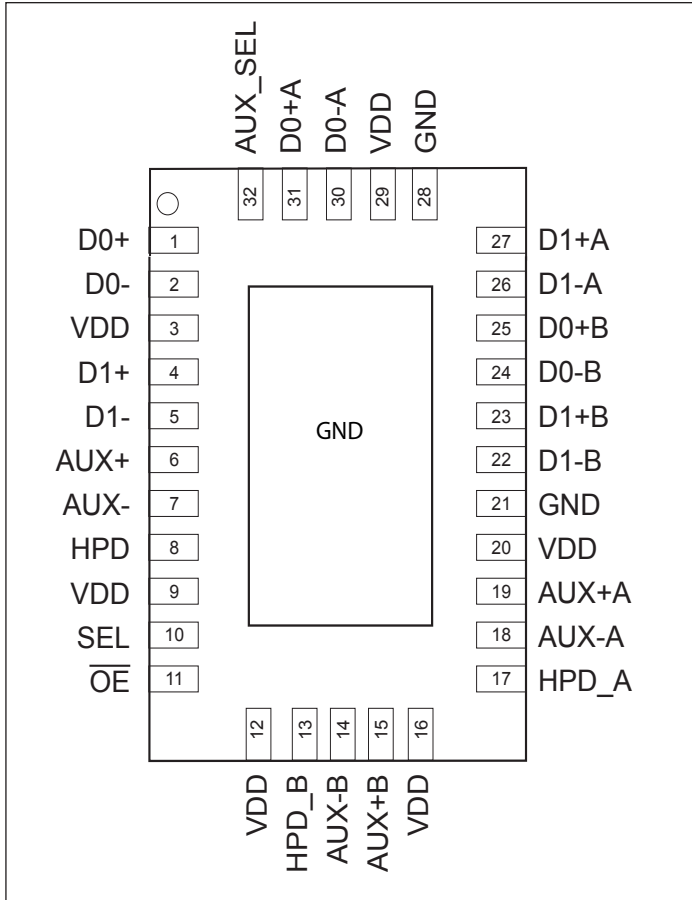

Truth Table

$\overline{\text{OE}}$	SEL	AUX_SEL	Function
Low	Low	Low	Port A active for all channels
Low	Low	High	Port A for HS, port B for HPD/AUX
Low	High	Low	Port B for HS, port A for HPD/AUX
Low	High	High	Port B active for all channels
High	x	x	All I/O's are hi-z and IC is power down

Pin Description

pin#	pin Name	Signal Type	Description
1	D0+	I/O	positive differential signal 0 for COM port
2	D0-	I/O	negative differential signal 0 for COM port
3	VDD	Power	3.3V +/-10% power supply
4	D1+	I/O	positive differential signal 1 for COM port
5	D1-	I/O	negative differential signal 1 for COM port
6	AUX+	I/O	positive differential signal for AUX COM port
7	AUX-	I/O	negative differential signal for AUX COM port
8	HPD	I/O	HPD for COM port
9	VDD	Power	3.3V +/-10% power supply
10	SEL	I	switch logic control. If HIGH, then path B is selected for high speed channels only If LOW, then path A is selected for high speed channels only
11	\overline{OE}	I	Output enable. if \overline{OE} is low, IC is enabled. If \overline{OE} is high, then IC is power down and all I/Os are hi-z
12	VDD	Power	3.3V +/-10% power supply
13	HPD_B	I/O	HPD for port B
14	AUX-B	I/O	negative differential signal for AUX, port B
15	AUX+B	I/O	positive differential signal for AUX, port B
16	VDD	Power	3.3V +/-10% power supply
17	HPD_A	I/O	HPD for port A
18	AUX-A	I/O	negative differential signal for AUX, port A
19	AUX+A	I/O	positive differential signal for AUX, port A
20	VDD	Power	3.3V +/-10% power supply
21	GND	Ground	Ground
22	D1-B	I/O	negative differential signal 1 for port B
23	D1+B	I/O	positive differential signal 1 for port B
24	D0-B	I/O	negative differential signal 0 for port B
25	D0+B	I/O	positive differential signal 0 for port B
26	D1-A	I/O	negative differential signal 1 for port A
27	D1+A	I/O	positive differential signal 1 for port A
28	GND	Ground	Ground
29	VDD	Power	3.3V +/-10% power supply
30	D0-A	I/O	negative differential signal 0 for port A
31	D0+A	I/O	positive differential signal 0 for port A
32	AUX_SEL	I	switches only the AUX and HPD channels from port A vs. port B If High, path B is selected If LOW, path A is selected

Maximum Ratings

(Above which useful life may be impaired. For user guidelines, not tested.)

Storage Temperature	-65°C to +150°C
Supply Voltage to Ground Potential	-0.5V to +4.2V
DC Input Voltage	-0.5V to V_{DD}
DC Output Current	120mA
Power Dissipation	0.5W

Note: Stresses greater than those listed under MAXIMUM RATINGS may cause permanent damage to the device. This is a stress rating only and functional operation of the device at these or any other conditions above those indicated in the operational sections of this specification is not implied. Exposure to absolute maximum rating conditions for extended periods may affect reliability.

DC Electrical Characteristics for Switching over Operating Range (TA = -40°C to +85°C, VDD = 3.3V ±10%)

Parameter	Description	Test Conditions ⁽¹⁾	Min	Typ ⁽¹⁾	Max	Units
V _{IH}	Input HIGH Voltage	Guaranteed HIGH level	1.5			V
V _{IL}	Input LOW Voltage	Guaranteed LOW level			0.75	
V _{IK}	Clamp Diode Voltage, Dx	V _{DD} = Max., I _{IN} = -18mA		-1.6	-1.8	
I _{IH}	Input HIGH Current	V _{DD} = Max., V _{IN} = V _{DD}			±5	µA
I _{IL}	Input LOW Current	V _{DD} = Max., V _{IN} = GND			±5	
I _{OFF_SB}	I/O leakage when part is off for side band signals only (DDC, AUX, HPD)	V _{DD} = 0V, V _{INPUT} = 0V to 3.6V			20	
R _{ON_HS}	On resistance between input to output for high speed signals	V _{DD} = 3.3V, V _{input} = 0V to 2V, I _{INPUT} = 20mA		10		Ohm
R _{ON_AUX}	On resistance between input to output for side-band signals (AUX)	V _{DD} = 3.3V, V _{input} = 0 to 3.3V, I _{INPUT} = 20mA		7		Ohm
Aux _{ss}	Signal Swing Tolerance in Aux path	V _{DD} = 3.0V	-0.5		3.6	V
HPD _I	Input voltage tolerance on HPD path				5.5	V
HPD _O	Output voltage on HPD path	HPD input from 0V to 5.25V			3.6	V

Power Supply Characteristics (TA = -40°C to +85°C)

Parameter	Description	Test Conditions ⁽¹⁾	Min	Typ ⁽¹⁾	Max	Units
I _{CC}	Quiescent Power Supply Current	V _{DD} = 3.3V., V _{IN} = GND or V _{DD}		320	500	µA

Dynamic Electrical Characteristics over Operating Range ($T_A = -40^\circ \text{ to } +85^\circ\text{C}$, $V_{DD} = 3.3\text{V} \pm 10\%$)

Parameter	Description	Test Conditions	Typ.	Max	Units
X _{TALK}	Crosstalk on High Speed Channels	See Fig. 1 for Measurement Setup	f = 2.7 GHz	-25dB	dB
			f = 1.35 GHz	-32dB	
O _{IRR}	OFF Isolation on High Speed Channels	See Fig. 2 for Measurement Setup,	f = 2.7 GHz	-22dB	
			f = 1.35 GHz	-30dB	
I _{LOSS}	Differential Insertion Loss on High Speed Channels	@5.4Gbps (see figure 3)	-1.7		dB
R _{loss}	Differential Return Loss on high speed channels	@ 2.7GHz	-16		dB
BW _{Dx±}	Bandwidth -3dB for Main high speed path (Dx±)	See figure 3	4.7		GHz
BW _{AUX/HPD}	-3dB BW for AUX and HPD signals	See figure 3	1.5		GHz
T _{sw a-b}	time it takes to switch from port A to port B			1	us
T _{sw b-a}	time it takes to switch from port B to port A			1	us
T _{startup}	V _{dd} valid to channel enable			10	us
T _{wakeup}	Enabling output by changing $\overline{\text{OE}}$ from low to High			10	us

1. For Max. or Min. conditions, use appropriate value specified under Electrical Characteristics for the applicable device type.
2. Typical values are at $V_{DD} = 3.3\text{V}$, $T_A = 25^\circ\text{C}$ ambient and maximum loading.

Switching Characteristics ($T_A = -40^\circ \text{ to } +85^\circ\text{C}$, $V_{DD} = 3.3\text{V} \pm 10\%$)

Parameter	Description	Min.	Typ.	Max.	Units
T _{pd}	Propagation delay (input pin to output pin)		80		ps
t _{b-b}	Bit-to-bit skew within the same differential pair		5		ps
t _{ch-ch}	Channel-to-channel skew			50	ps

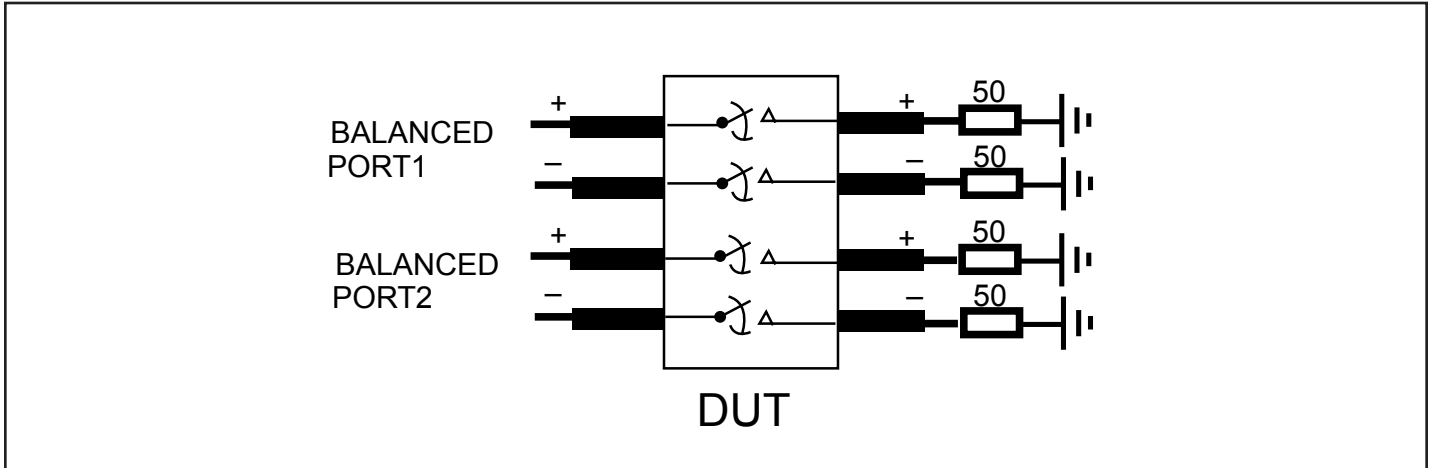

Fig 1. Crosstalk Setup

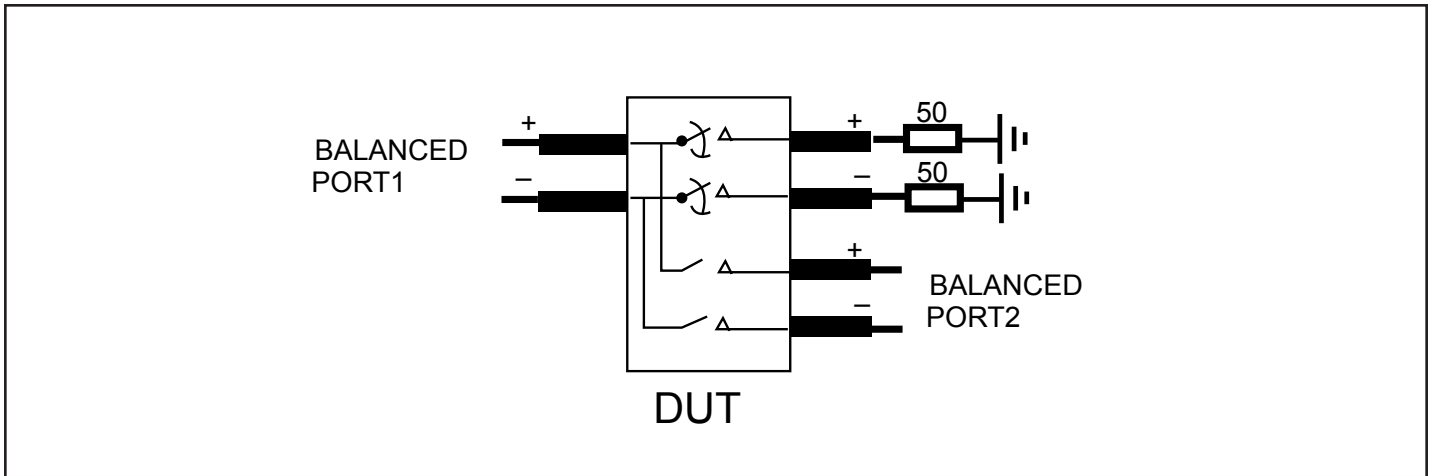

Fig 2. Off-isolation setup

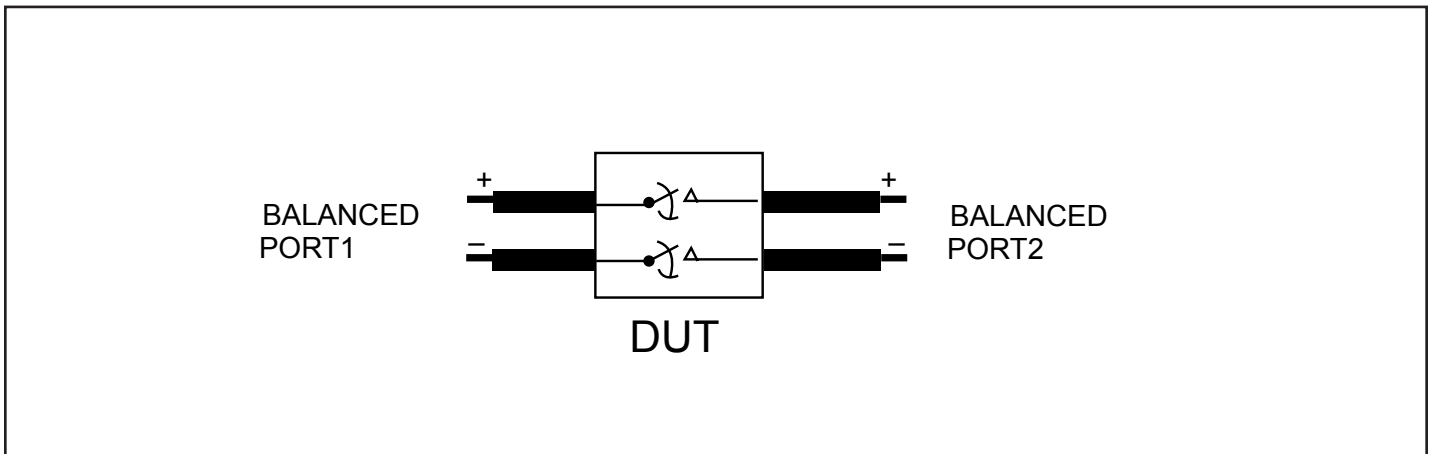

Fig 3. Differential Insertion Loss set up

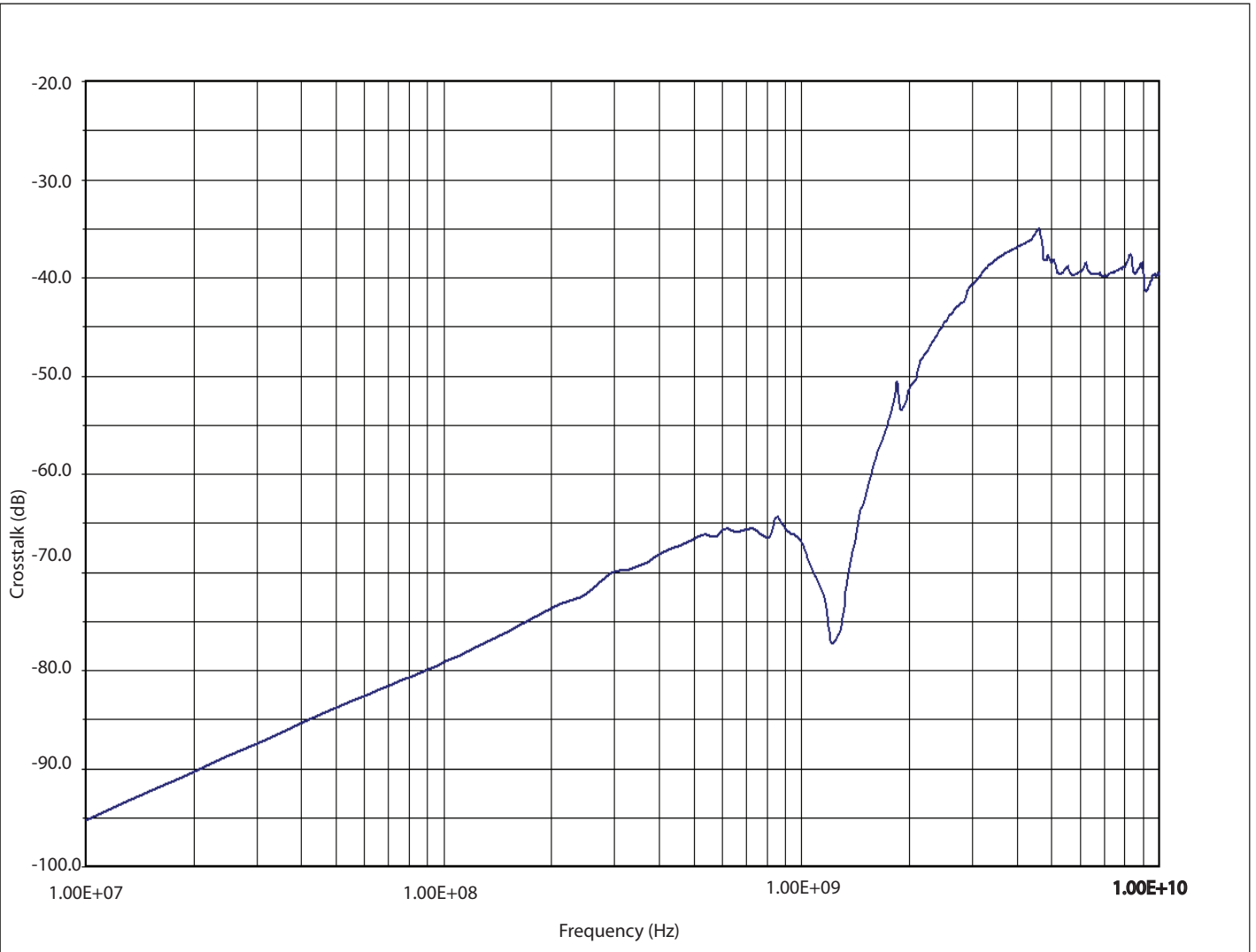

Fig 4. Xtalk for high speed channels (D0 and D1)

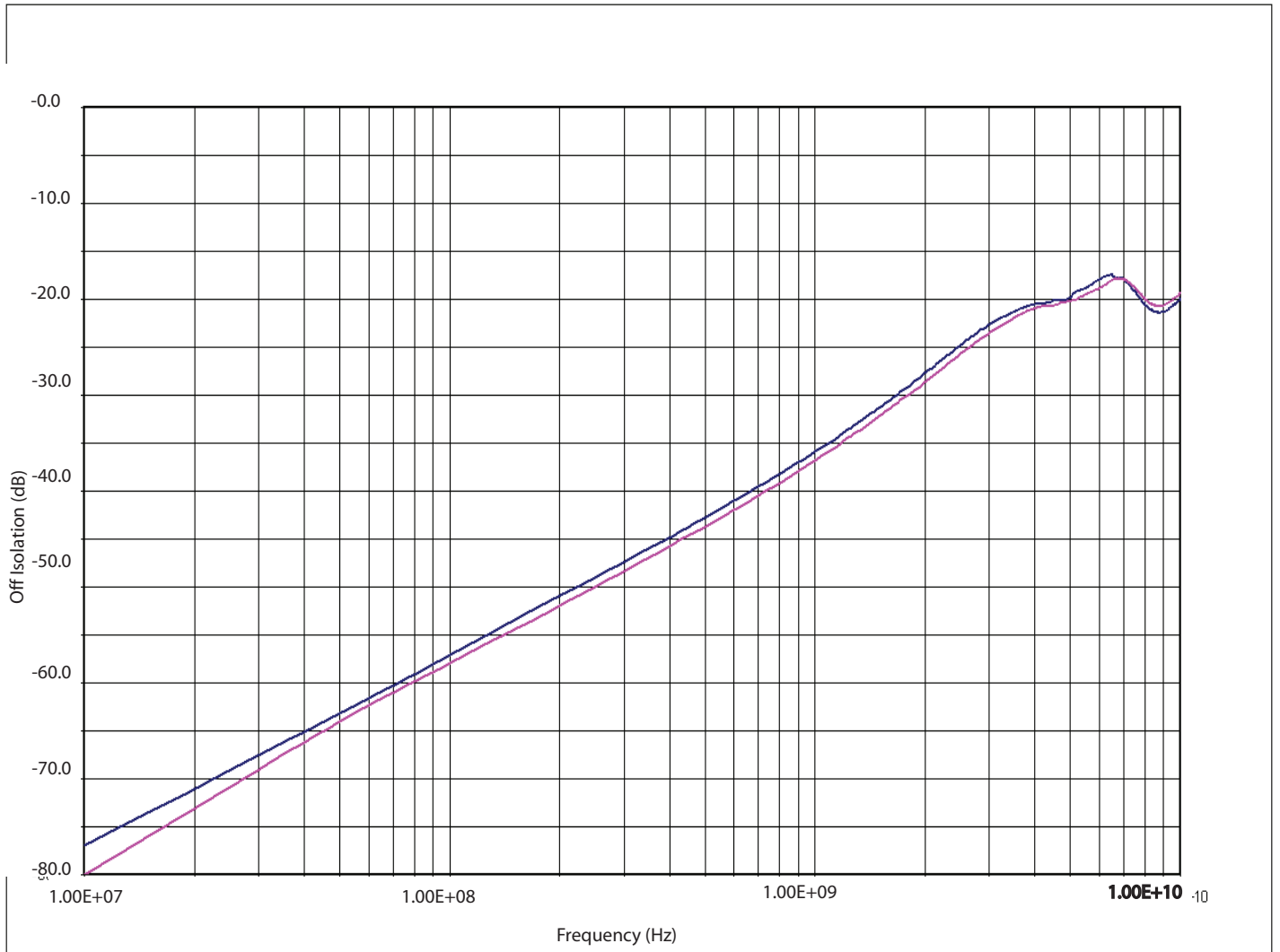

Fig 5. Off Isolation for high speed channels (D0 and D1). Red is for path B and Blue is for path A

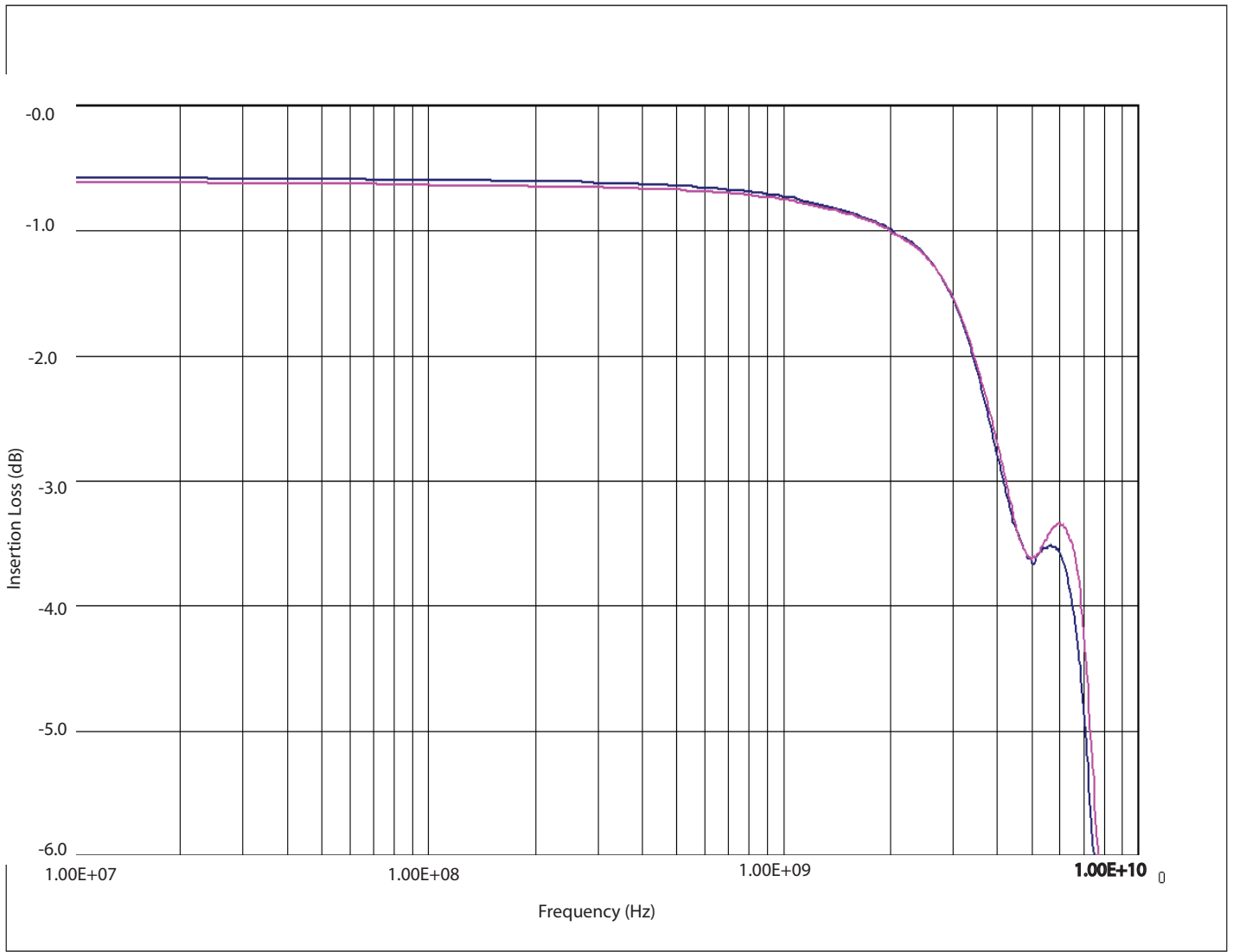
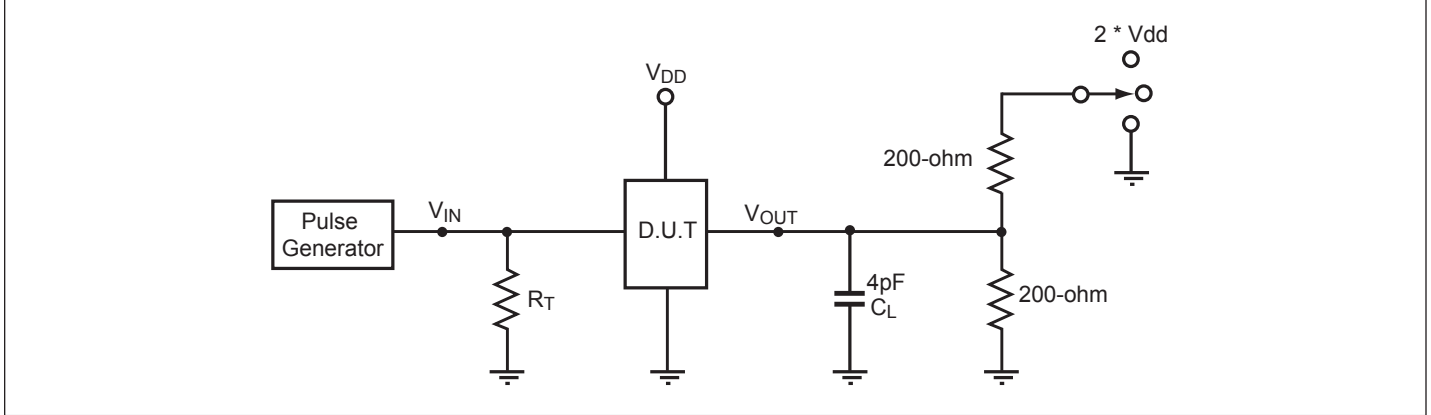

Fig 6. Insertion Loss for high speed channels, D0 and D1. Red is for path B and Blue is for path A

Test Circuit for Electrical Characteristics(1-5)



Notes:

1. C_L = Load capacitance: includes jig and probe capacitance.
2. R_T = Termination resistance: should be equal to Z_{OUT} of the Pulse Generator
3. Output 1 is for an output with internal conditions such that the output is low except when disabled by the output control.
4. Output 2 is for an output with internal conditions such that the output is high except when disabled by the output control.
5. All input impulses are supplied by generators having the following characteristics: $PRR \leq \text{MHz}$, $Z_O = 50\Omega$, $t_R \leq 2.5\text{ns}$, $t_F \leq 2.5\text{ns}$.
6. The outputs are measured one at a time with one transition per measurement.

Switching Waveforms

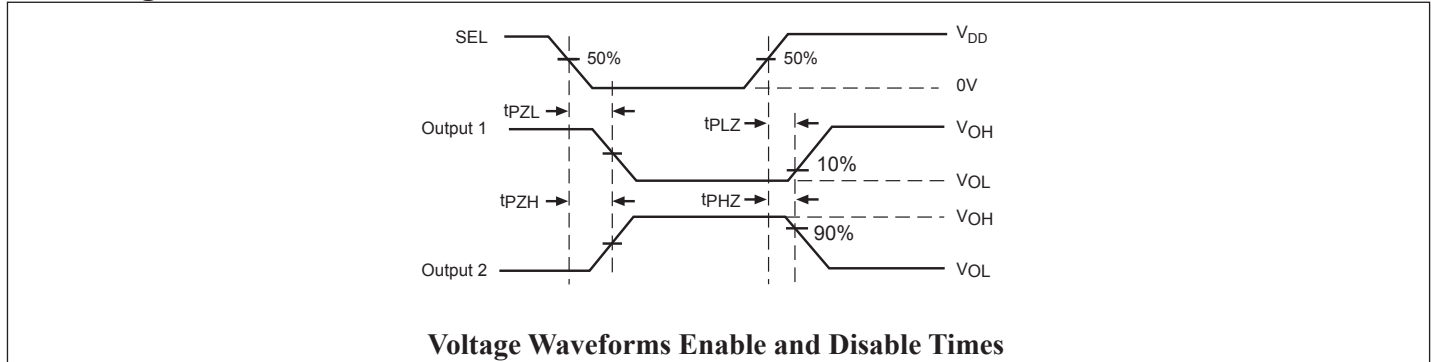

Switch Positions

Test	Switch
t_{PLZ} , t_{PZL} (output on B-side)	$2 * V_{dd}$
t_{PHZ} , t_{PZH} (output on B-side)	GND
Prop Delay	Open

Test Circuit for Dynamic Electrical Characteristics

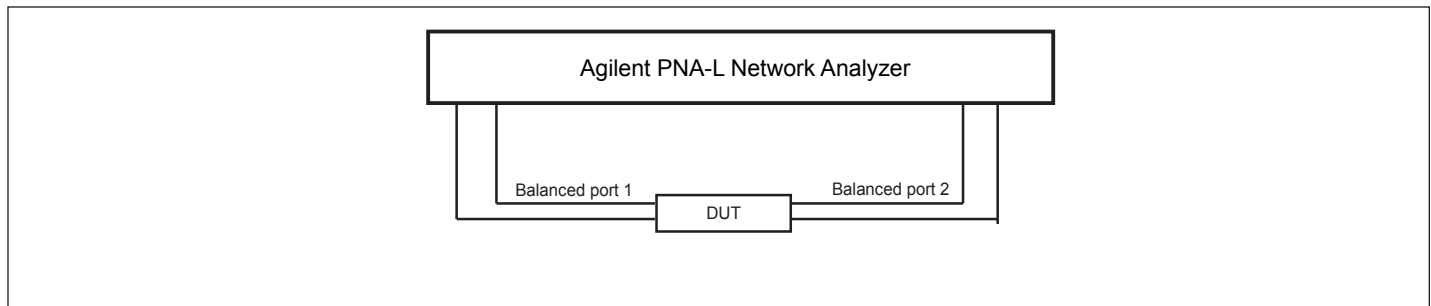

Packaging Mechanical: 32-Contact TQFN (ZL)

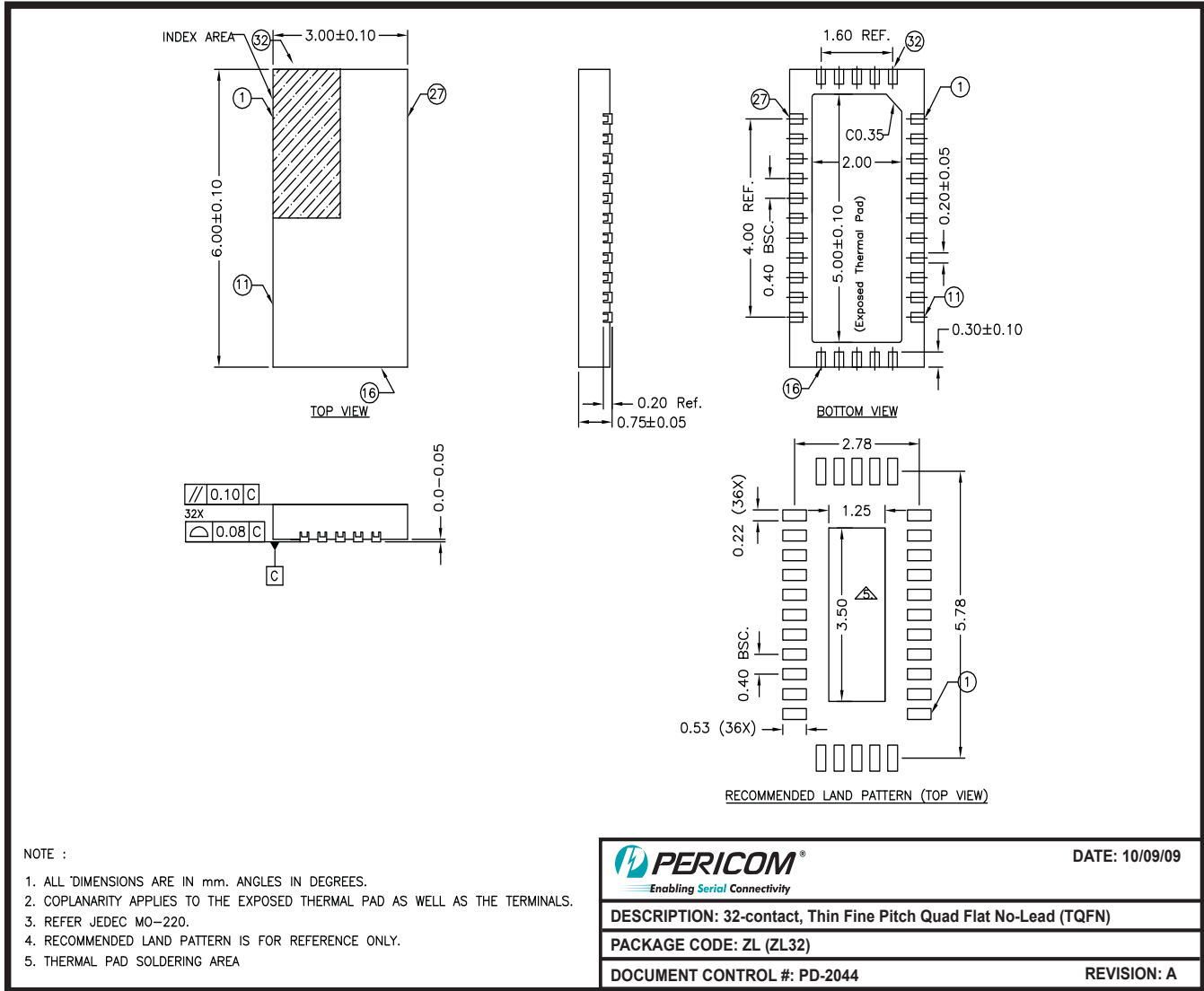

09-0125

Note:

For latest package info, please check: <http://www.pericom.com/products/packaging/mechanicals.php>

Ordering Information

Ordering Code	Package Code	Package Description
PI3VDP3212ZLE	ZL	Pb-free & Green, 32-contact TQFN

Notes:

- Thermal characteristics can be found on the company web site at www.pericom.com/packaging/
- "E" denotes Pb-free and Green
- Adding an "X" at the end of the ordering code denotes tape and reel packaging