

### Features

- Near-Zero propagation delay
- 5Ω switches connect inputs to outputs
- Fast Switching Speed: 4.8ns max.
- Ultra-Low Quiescent Power: 0.1μA typical  
– Ideally suited for notebook applications
- Pin compatible with 74 series 257 logic devices
- Packaging (Pb-free & Green available):  
– 16-pin 150 mil wide plastic QSOP (Q)

### Description

Pericom Semiconductor's PI3B3257A is a 3.3 volt, Quad 2:1 multiplexer/demultiplexer with three-state outputs that is pinout and function compatible with the PI74FCT257T, 74F257, and 74ALS/AS/LS257. Inputs can be connected to outputs with low On-Resistance (5Ω) with no additional ground bounce noise or propagation delay.

### Block Diagram

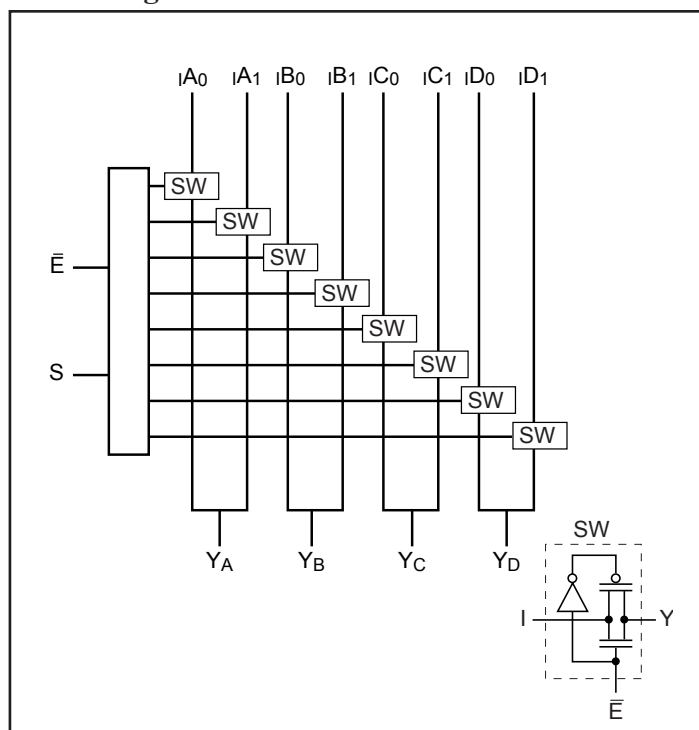

### Pin Configuration

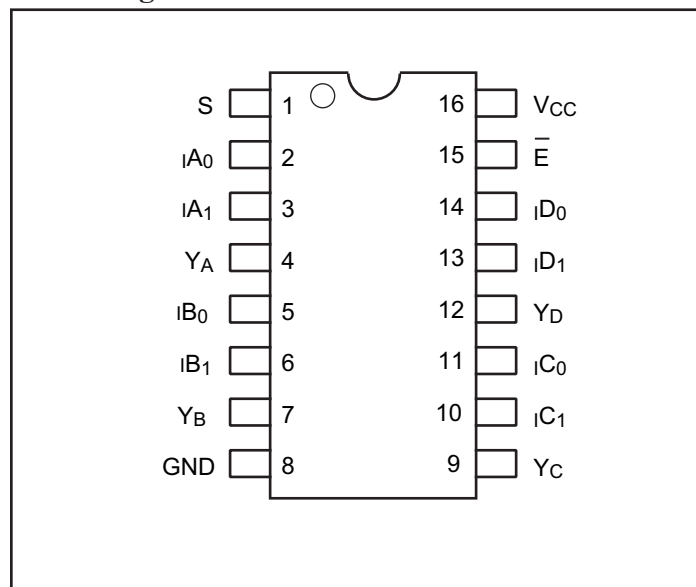

### Pin Description

Pin Name	Description
$I_{AN}-I_{DN}$	Data Inputs
S	Select Inputs
$\bar{E}$	Enable
$Y_A-Y_D$	Data Outputs
GND	Ground
$V_{CC}$	Power
NC	No Connect

### Truth Table<sup>(1)</sup>

$\bar{E}$	S	$Y_A$	$Y_B$	$Y_C$	$Y_D$	Function
H	X	Hi-Z	Hi-Z	Hi-Z	Hi-Z	Disable
L	L	$I_{A0}$	$I_{B0}$	$I_{C0}$	$I_{D0}$	S = 0
L	H	$I_{A1}$	$I_{B1}$	$I_{C1}$	$I_{D1}$	S = 1

#### Note:

1. H = High Voltage Level  
L = Low Voltage Level

### Maximum Ratings

(Above which the useful life may be impaired. For user guidelines, not tested.)

Storage Temperature .....	-65°C to +150°C
Ambient Temperature with Power Applied .....	-40°C to +85°C
Supply Voltage to Ground Potential.....	-0.5V to +4.6V
DC Input Voltage .....	-0.5V to +4.6V
DC Output Current.....	120mA
Power Dissipation .....	0.5W

**Note:** Stresses greater than those listed under MAXIMUM RATINGS may cause permanent damage to the device. This is a stress rating only and functional operation of the device at these or any other conditions above those indicated in the operational sections of this specification is not implied. Exposure to absolute maximum rating conditions for extended periods may affect reliability.

### DC Electrical Characteristics (Over the Operating Range, $T_A = -40^\circ\text{C}$ to $+85^\circ\text{C}$ , $V_{CC} = 3.3\text{V} \pm 10\%$ )

Parameters	Description	Test Conditions <sup>(1)</sup>	Min.	Typ. <sup>(2)</sup>	Max.	Units
$V_{IH}$	Input HIGH Voltage	Guaranteed Logic HIGH Level	2			V
$V_{IL}$	Input LOW Voltage	Guaranteed Logic LOW Level	-0.5		0.8	
$I_{IH}$	Input HIGH Current	$V_{CC} = \text{Max.}, V_{IN} = V_{CC}$			$\pm 1$	$\mu\text{A}$
$I_{IL}$	Input LOW Current	$V_{CC} = \text{Max.}, V_{IN} = \text{GND}$			$\pm 1$	
$I_{OZH}$	High Impedance Output Current	$0 \leq I_n, Y_n \leq V_{CC}$			$\pm 1$	
$V_{IK}$	Clamp Diode Voltage	$V_{CC} = \text{Min.}, I_{IN} = -18\text{mA}$			-1.2	V
$R_{ON}$	Switch On-Resistance <sup>(3)</sup>	$V_{CC} = \text{Min.}, V_{IN} = 0.0\text{V}, I_{ON} = 48\text{mA}$ or $64\text{mA}$		5	7	$\Omega$
		$V_{CC} = \text{Min.}, V_{IN} = 2.4\text{V}, I_{ON} = 15\text{mA}$		8	17	

**Notes:**

- For Max. or Min. conditions, use appropriate value specified under Electrical Characteristics for the applicable device type.
- Typical values are at  $V_{CC} = 3.3\text{V}$ ,  $T_A = 25^\circ\text{C}$  ambient and maximum loading.
- Measured by the voltage drop between I and Y pin at indicated current through the switch. On-Resistance is determined by the lower of the voltages on the two (I,Y) pins.

### Capacitance ( $T_A = 25^\circ\text{C}$ , $f = 1\text{ MHz}$ )

Parameters <sup>(1)</sup>	Description	Test Conditions	Typical	Units
$C_{IN}$	Input Capacitance	$V_{IN} = 0\text{V}$	2	pF
$C_{OFFYN}$	$Y_N$ Capacitance, Switch OFF		7.5	
$C_{OFFIN}$	$I_N$ Capacitance, Switch OFF		4.0	
$C_{ON}$	$I_N/Y_N$ Capacitance, Switch ON		11	

**Notes:**

- This parameter is determined by device characterization but is not production tested.

### Power Supply Characteristics

Parameters	Description	Test Conditions <sup>(1)</sup>		Min.	Typ. <sup>(2)</sup>	Max.	Units
I <sub>CC</sub>	Quiescent Power Supply Current	V <sub>CC</sub> = Max.	V <sub>IN</sub> = GND or V <sub>CC</sub>		0.1	3.0	μA
ΔI <sub>CC</sub>	Supply Current per Input @ TTL HIGH <sup>(3, 4)</sup>	V <sub>CC</sub> = Max.	V <sub>IN</sub> = 3.0			750	

**Notes:**

- For Max. or Min. conditions, use appropriate value specified under Electrical Characteristics for the applicable device.
- Typical values are at V<sub>CC</sub> = 3.3V, +25°C ambient.
- Per TTL driven input (control inputs only); I and Y pins do not contribute to I<sub>CC</sub>.
- This current applies to the control inputs only and represent the current required to switch internal capacitance at the specified frequency. The I and Y inputs generate no significant AC or DC currents as they transition. This parameter is not tested, but is guaranteed by design.

### Switching Characteristics Over Operating Range

Parameters	Description	Conditions	Com.		Units
			Min.	Max.	
t <sub>IY</sub>	Propagation Delay In to Yn <sup>(1,2)</sup>	C <sub>L</sub> = 50pF R <sub>L</sub> = 500Ω		0.25	ns
t <sub>SY</sub>	Bus Select Time, Sn to Yn		1	4.5	
t <sub>PZH</sub> t <sub>PZL</sub>	Bus Enable Time, E to Yn		1	4.5	
t <sub>PHZ</sub> t <sub>PLZ</sub>	Bus Disable Time, E to Yn		1	4.8	

**Notes:**

- This parameter is guaranteed but not tested on Propagation Delays.
- The bus switch contributes no propagational delay other than the RC delay of the On-Resistance of the switch and the load capacitance. The switch's time constant alone is of the order of 0.25ns for 50pF load. Since this time constant is much smaller than the rise/fall times of typical driving signals, it adds very little propagational delay to the system. Propagational delay of the bus switch when used in a system is determined by the driving circuit on the driving side of the switch and its interaction with the load on the driven side.

### Applications Information

#### Logic Inputs

The logic control inputs can be driven up to +3.6V regardless of the supply voltage. For example, given a + 3.3V supply, IN may be driven low to 0V and high to 3.6V. Driving IN Rail-to-Rail® minimizes power consumption.

#### Power-Supply Sequencing and Hot-Plug Information

Proper power-supply sequencing is recommended for all CMOS devices. Always apply V<sub>CC</sub> and GND before applying signals to input/output or control pins.

*Rail-to-Rail is a registered trademark of Nippon Motorola, Ltd.*

**Packaging Mechanical: 16-Pin QSOP (Q)**

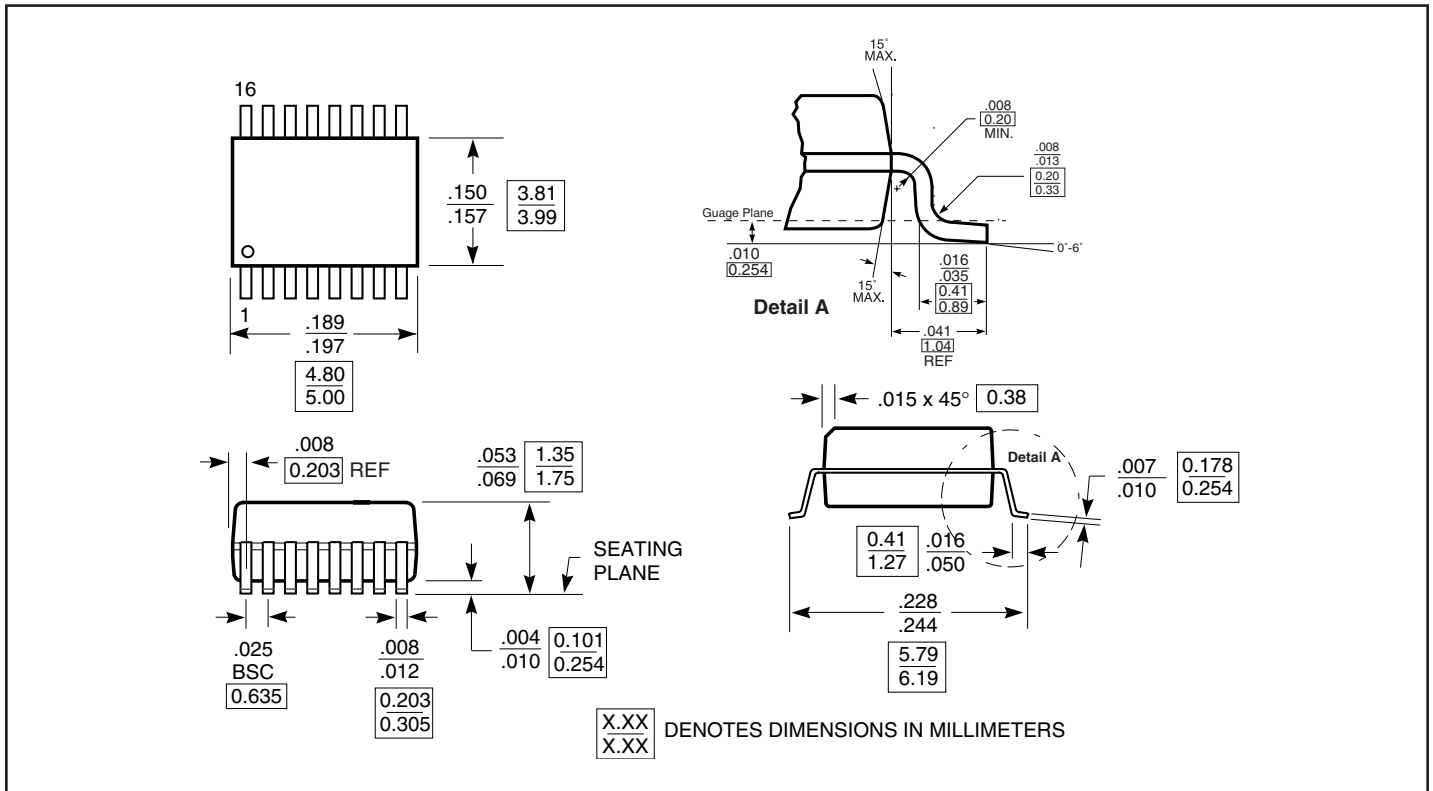

**Ordering Information**

Ordering Code	Packaging Code	Package Description
PI3B3257AQ	Q	16-pin 150-mil wide plastic QSOP
PI3B3257AQE	Q	Pb-Free & Green, 16-pin 150-mil wide plastic QSOP

**Notes:**

- Thermal characteristics can be found on the company web site at [www.pericom.com/packaging/](http://www.pericom.com/packaging/)
- E = Pb-free & Green
- Adding an X suffix = Tape/Reel