

## 1.8V, 1.8GHz, Differential Broadband Signal Switch, 4-Differential Channel, 2:1 Mux/DeMux Switch, w/ Single Enable

### Features

- -3dB BW of 1.8 GHz
- 4 Differential Channel, 2:1 Mux/DeMux
- Low Bit-to-Bit Skew
- Low Crosstalk: -68dB @ 10 MHz
- Low Off Isolation: -77dB @ 10 MHz
- V<sub>CC</sub> Operating Range: +1.5V to +2.0V
- ESD Tolerance: 8kV HBM I/O, 2kV HBM select pin
- Packaging (Pb-free & Green):  
– 42-contact, TQFN (ZH42)

### Applications

- Routers
- Switch
- Server
- Notebook
- Medical Equipment

### Block Diagram

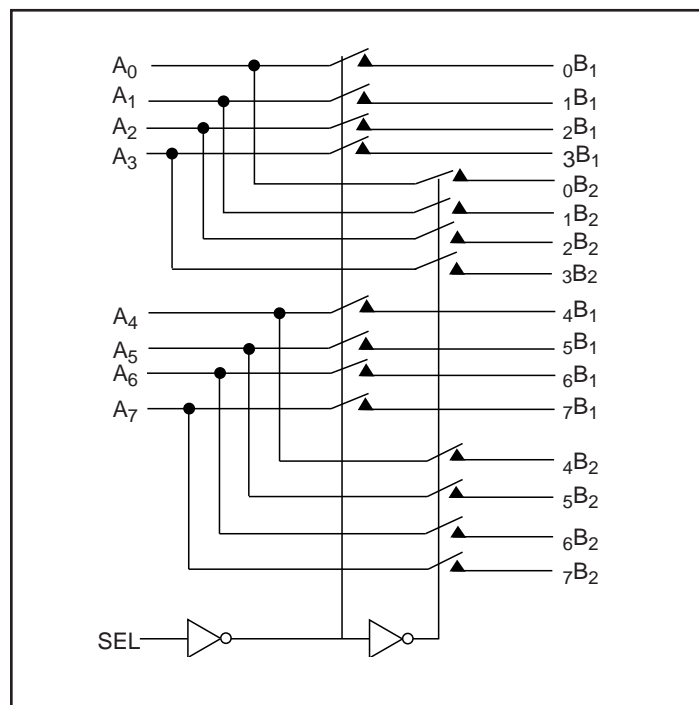

### Description

Pericom Semiconductor's PI2DBS412 is an 8-to-4 differential channel multiplexer/demultiplexer switch. Using a specialized design scheme, Pericom has been able to achieve a performance of 3Gbps data rate mux/de-mux function. Due to its bi-directional nature, the PI2DBS412 can be used to allocate bandwidth to two different locations as a demux, or connect two high-speed sources to a single receiver as a mux.

The PI2DBS412 will target the following standards: SAS, SATA I, SATA II, INFINIBAND, HYPERTRANSPORT, and RAP ID I/O.

We recommend customers to use Pericom's Re-Driver devices in conjunction with the PI2DBS412 in applications requiring long trace lengths to ensure signal integrity.

### Pin Description

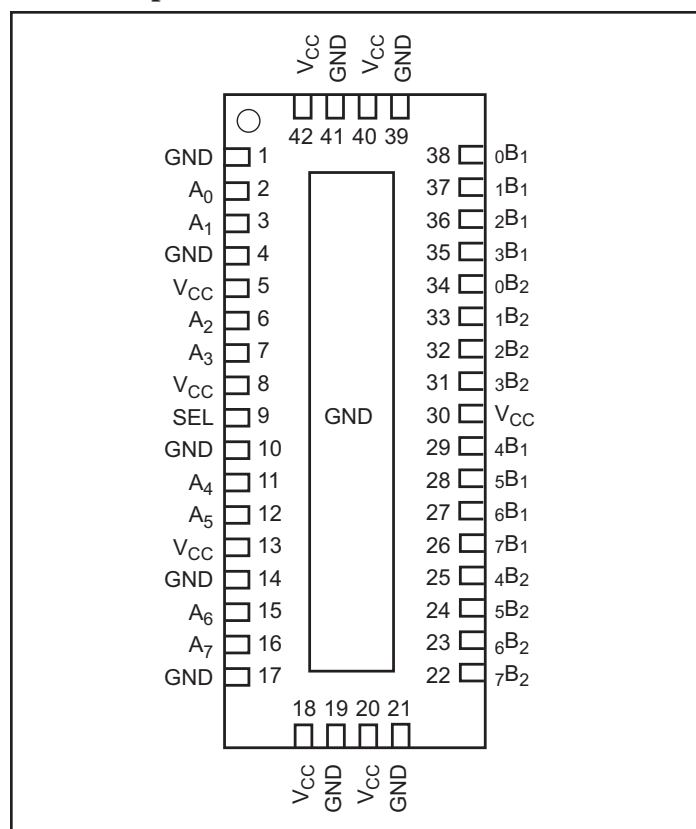

### Truth Table

Function	SEL
A <sub>N</sub> to N <sub>B1</sub>	L
A <sub>N</sub> to N <sub>B2</sub>	H

### Maximum Ratings

(Above which useful life may be impaired. For user guidelines, not tested.)

Storage Temperature.....	-65°C to +150°C
Supply Voltage to Ground Potential.....	-0.5V to +2.5V
DC Input Voltage .....	-0.5V to $V_{CC}$
DC Output Current.....	120mA
Power Dissipation.....	0.5W

**Note:**

Stresses greater than those listed under MAXIMUM RATINGS may cause permanent damage to the device. This is a stress rating only and functional operation of the device at these or any other conditions above those indicated in the operational sections of this specification is not implied. Exposure to absolute maximum rating conditions for extended periods may affect reliability.

### DC Electrical Characteristics for Switching over Operating Range ( $T_A = -40^\circ\text{C}$ to $+85^\circ\text{C}$ , $V_{CC} = 1.5\text{V}$ to $2.0\text{V}$ )

Parameter	Description	Test Conditions <sup>(1)</sup>	Min.	Typ. <sup>(2)</sup>	Max.	Units
$V_{IH}$	Input HIGH Voltage	Guaranteed HIGH level	$0.65 \times V_{CC}$			V
$V_{IL}$	Input LOW Voltage	Guaranteed LOW level	-0.5		$0.35 \times V_{CC}$	
$V_{IK}$	Clamp Diode Voltage	$V_{CC} = \text{Max.}, I_{IN} = -18\text{mA}$		-0.7	-1.2	
$I_{IH}$	Input HIGH Current	$V_{CC} = \text{Max.}, V_{IN} = V_{CC}$			$\pm 5$	$\mu\text{A}$
$I_{IL}$	Input LOW Current	$V_{CC} = \text{Max.}, V_{IN} = \text{GND}$			$\pm 5$	

**Notes:**

- For Max. or Min. conditions, use appropriate value specified under Electrical Characteristics for the applicable device type.
- Typical values are at  $V_{CC} = 1.8\text{V}$ ,  $T_A = 25^\circ\text{C}$  ambient and maximum loading.

### Power Supply Characteristics

Parameters	Description	Test Conditions <sup>(1)</sup>	Min.	Typ. <sup>(2)</sup>	Max.	Units
$I_{CC}$	Quiescent Power Supply Current	$V_{CC} = \text{Max.}, V_{IN} = \text{GND}$ or $V_{CC}$		200		$\mu\text{A}$

**Notes:**

- For Max. or Min. conditions, use appropriate value specified under Electrical Characteristics for the applicable device type.
- Typical values are at  $V_{CC} = 1.8\text{V}$ ,  $T_A = 25^\circ\text{C}$  ambient and maximum loading.

### Dynamic Electrical Characteristics Over the Operating Range ( $T_A = -40^\circ$ to $+85^\circ\text{C}$ , $V_{CC} = 1.8\text{V} \pm 10\%$ , $\text{GND} = 0\text{V}$ )

Parameter	Description	Test Conditions <sup>(1)</sup>	Min.	Typ. <sup>(2)</sup>	Max.	Units
$X_{TALK}^{(3)}$	Crosstalk	See Fig. 1 for Measurement Setup, $f = 10\text{ MHz}$		-68		dB
$O_{IRR}^{(3)}$	OFF Isolation	See Fig. 2 for Measurement Setup, $f = 10\text{ MHz}$		-77		
$BW^{(3)}$	Bandwidth			1.8		GHz

**Notes:**

- For Max. or Min. conditions, use appropriate value specified under Electrical Characteristics for the applicable device type.
- Typical values are at  $V_{CC} = 1.8\text{V}$ ,  $T_A = 25^\circ\text{C}$  ambient and maximum loading.
- Guaranteed by design.

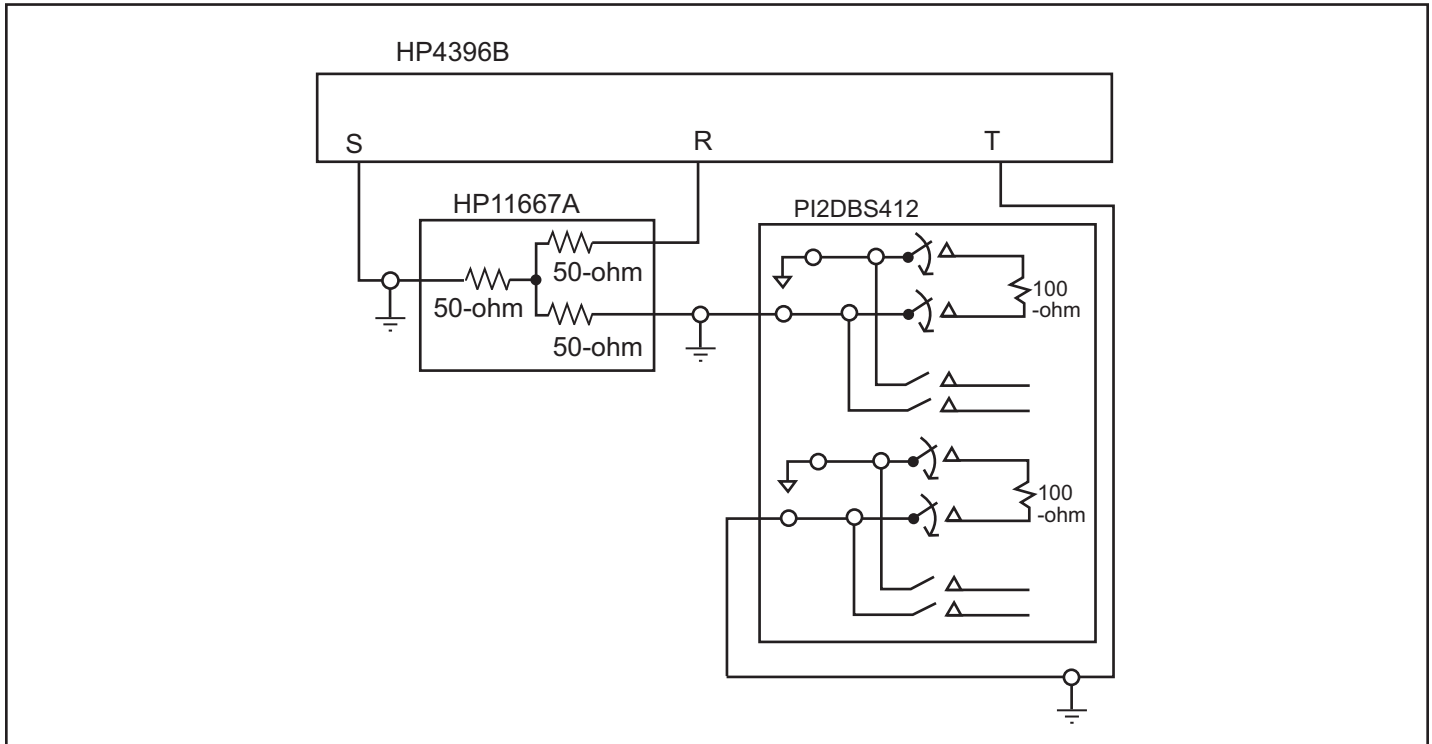

**Fig 1. Crosstalk Setup**

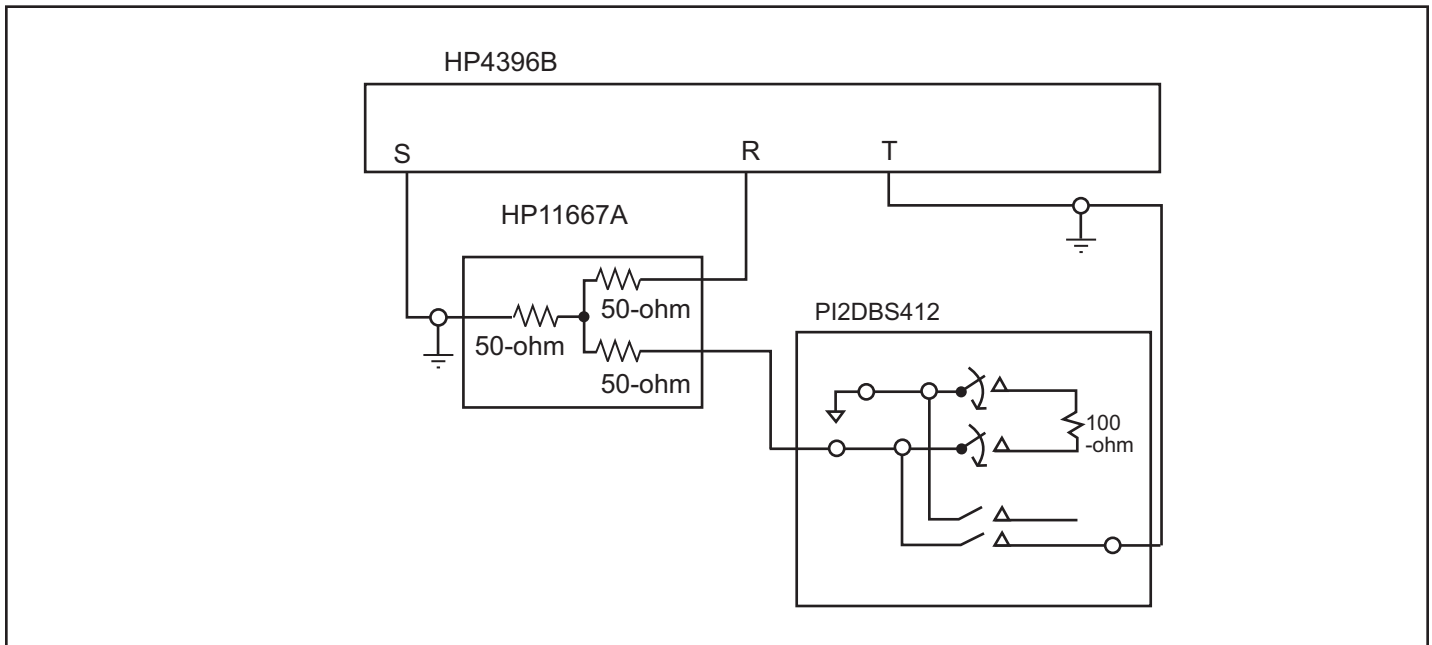

**Fig 2. Off-isolation setup**

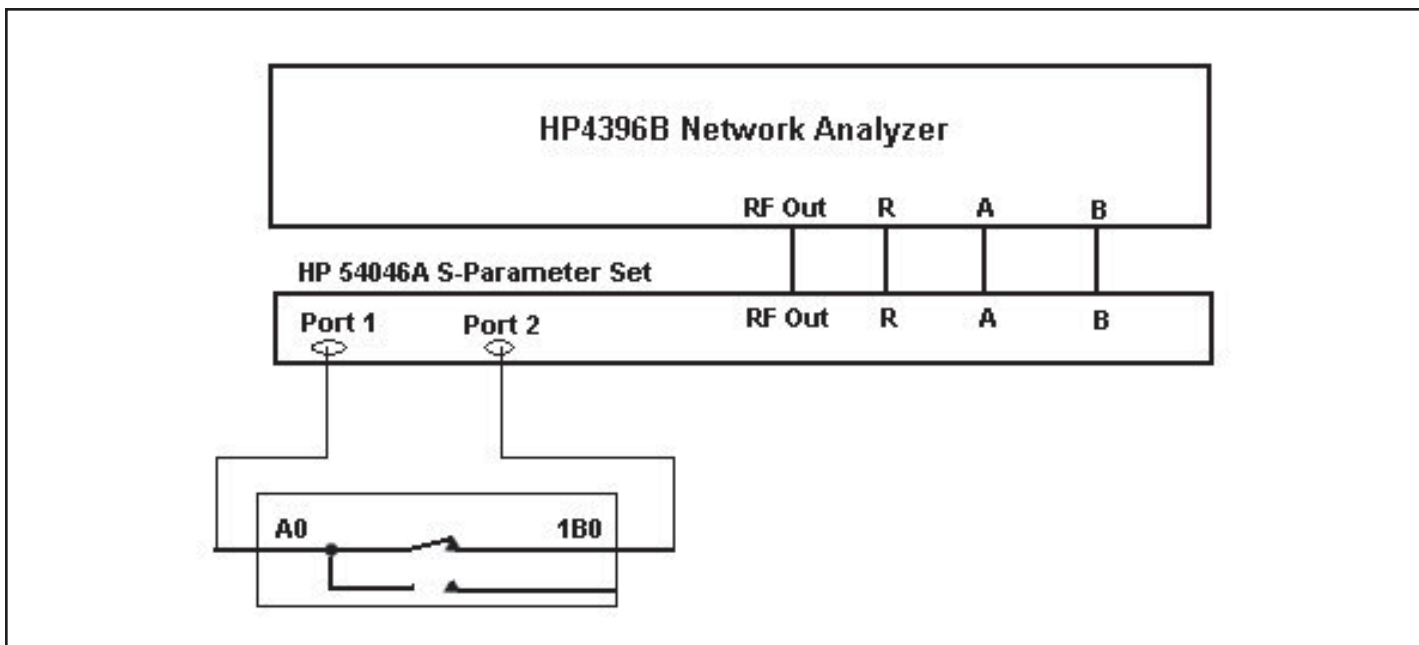

**Fig 3. S21 (Insertion Loss) and S11 (Reflection) SET-UP**

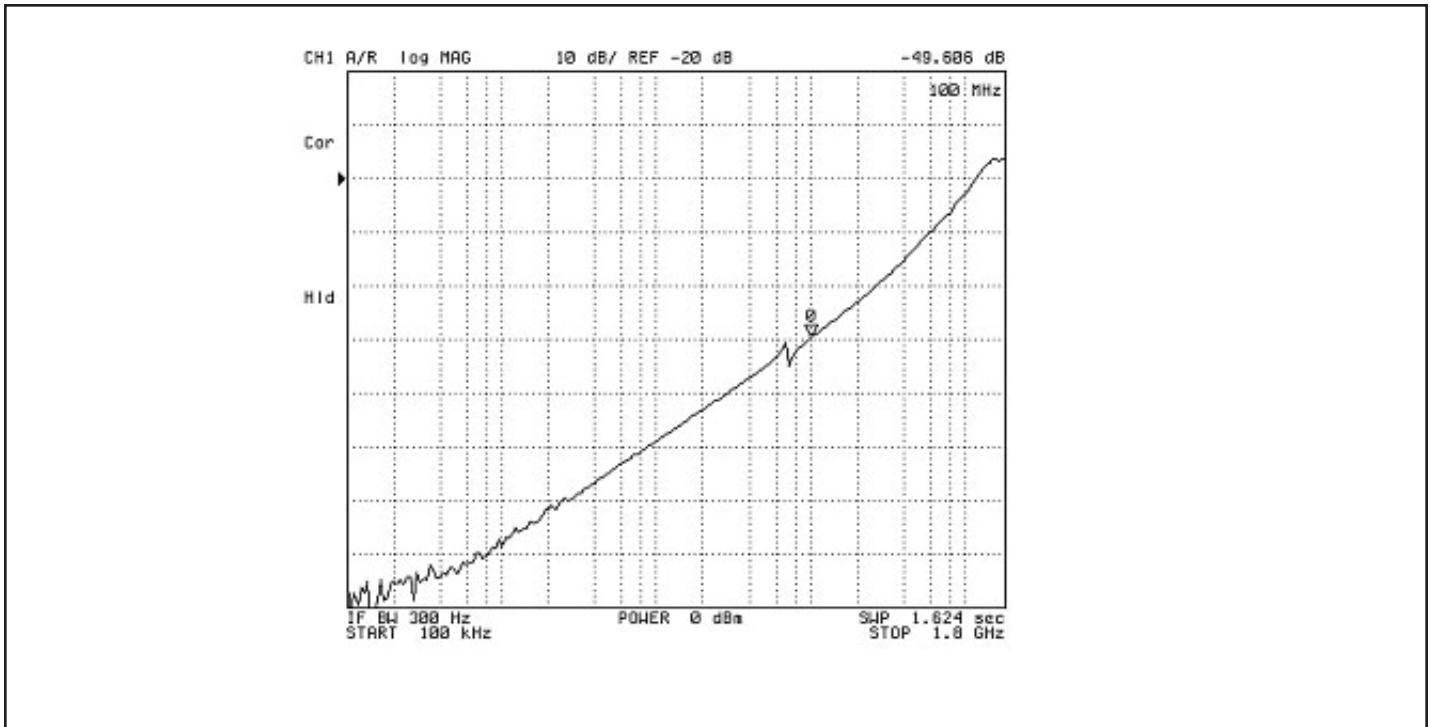

**Fig 4. Crosstalk**

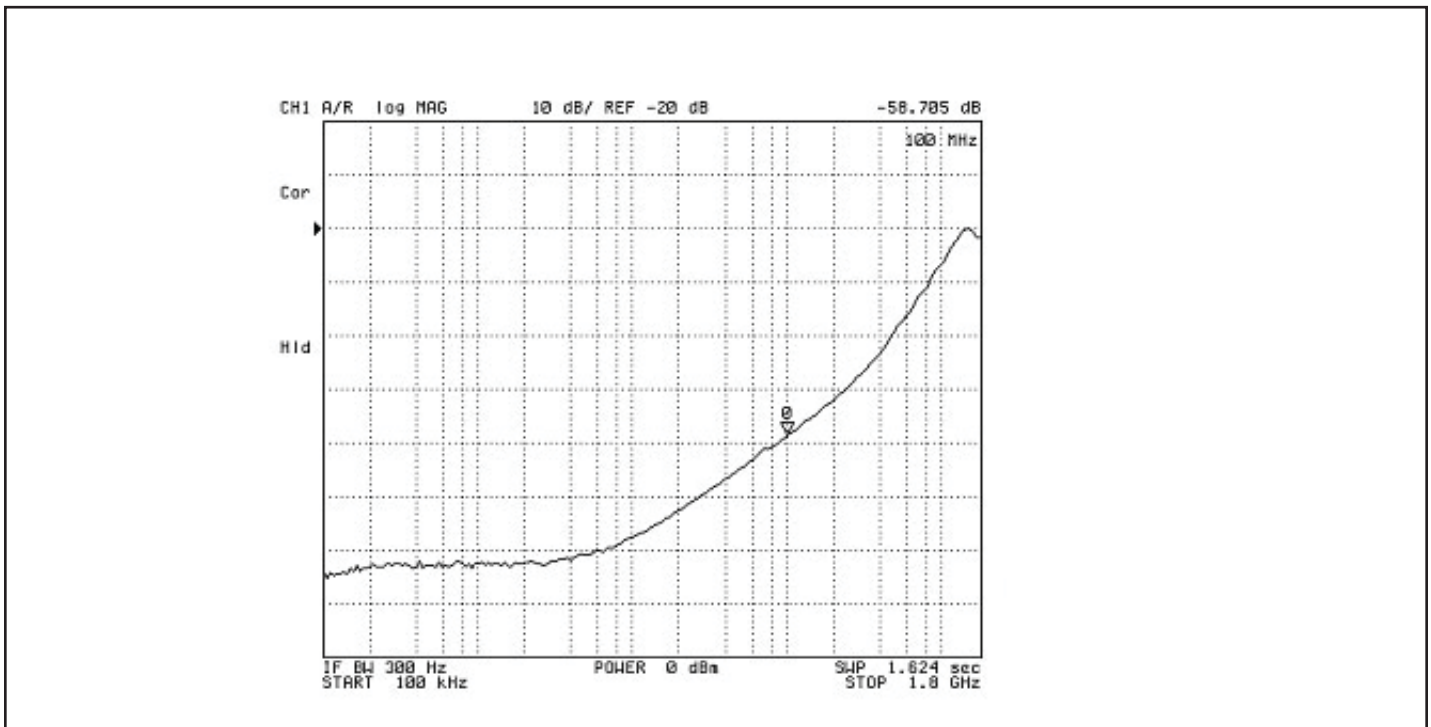

**Fig 5. Off Isolation**

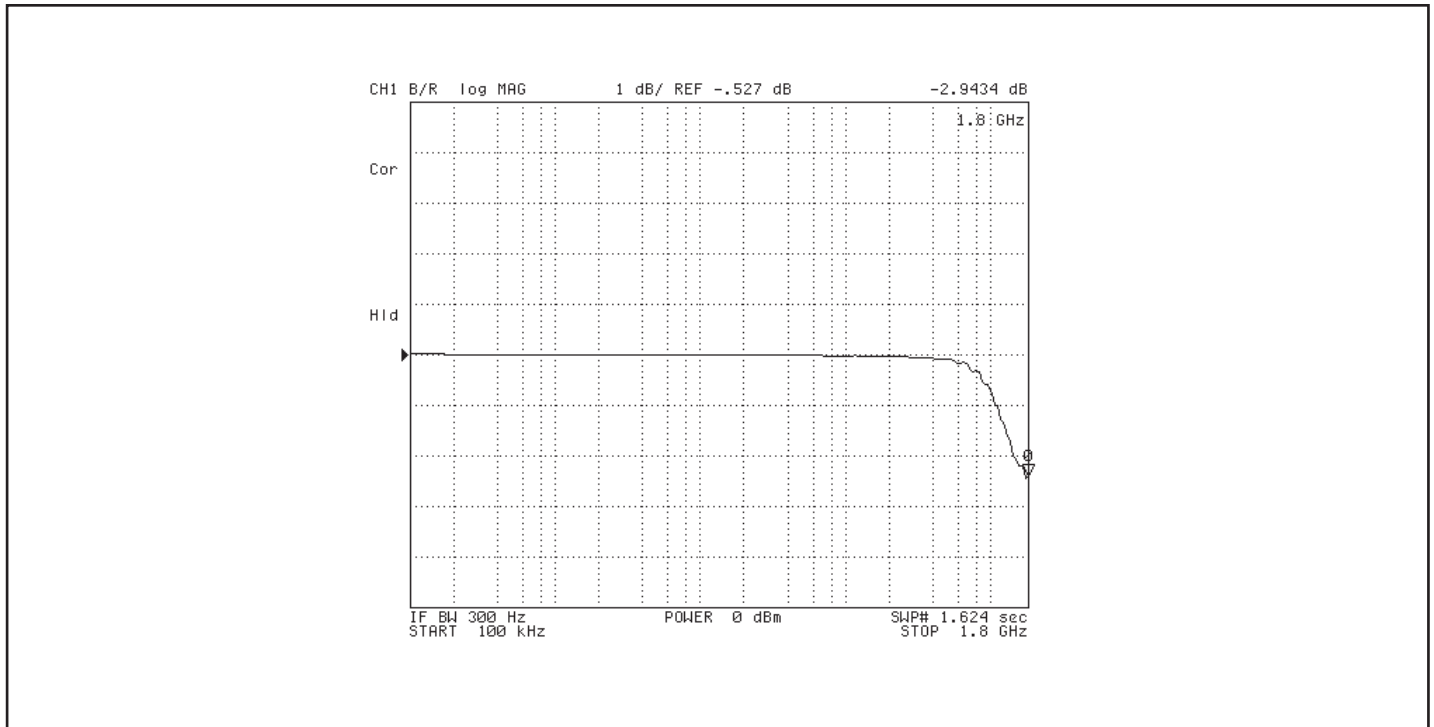

**Fig 6. Bandwidth**

**Switching Characteristics** ( $T_A = -40^\circ$  to  $+85^\circ\text{C}$ ,  $V_{CC} = 1.8\text{V} \pm 10\%$ )

Parameter	Description <sup>(1)</sup>	Min.	Max.	Units
$t_{PZH}$ , $t_{PZL}$	Line Enable Time - SEL to $A_N$ , $B_N$	0.5	8.0	ns
$t_{PHZ}$ , $t_{PLZ}$	Line Disable Time - SEL to $A_N$ , $B_N$	0.5	4.0	

**Notes:**

- For max. or min. conditions, use appropriate value specified under Electrical Characteristics for the applicable device type.

**Test Circuit for Electrical Characteristics**

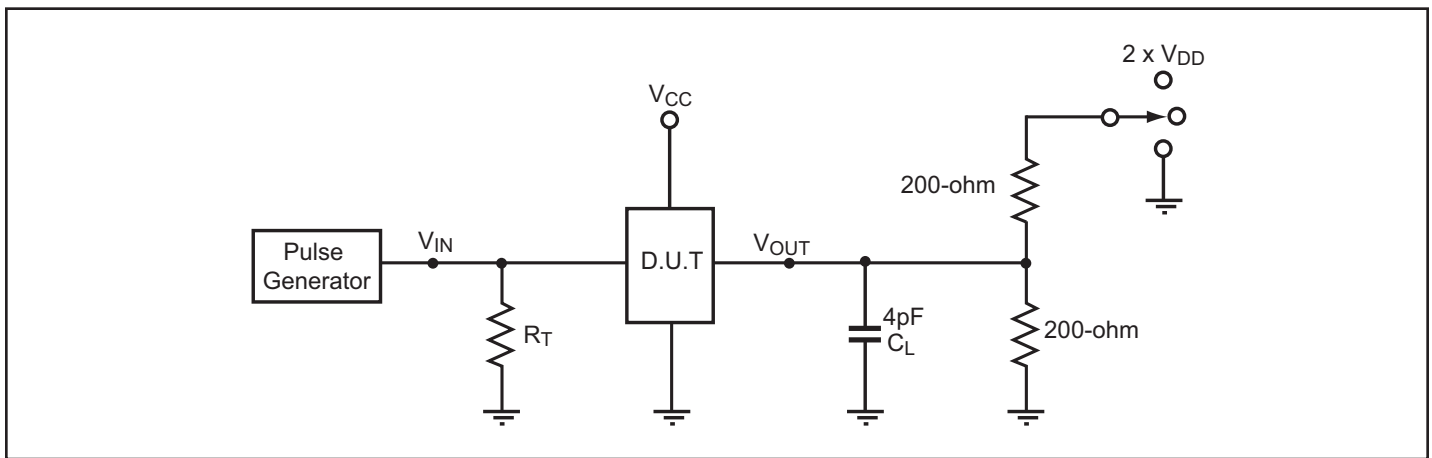

**Notes:**

- $C_L$  = Load capacitance: includes jig and probe capacitance.
- $R_T$  = Termination resistance: should be equal to  $Z_{OUT}$  of the Pulse Generator
- Waveform 1 is for an output with internal conditions such that the output is low except when disabled by the output control.
- Waveform 2 is for an output with internal conditions such that the output is high except when disabled by the output control.
- All input impulses are supplied by generators having the following characteristics:  $PRR \leq 10$  MHz,  $Z_O = 50\Omega$ ,  $t_R \leq 2.5\text{ns}$ ,  $t_F \leq 2.5\text{ns}$ .
- The outputs are measured one at a time with one transition per measurement.

**Switch Positions**

Test	Switch
$t_{PLZ}$ , $t_{PZL}$ (output on B-side)	$2 \times V_{CC}$
$t_{PHZ}$ , $t_{PZH}$ (output on B-side)	GND
Prop Delay	Open

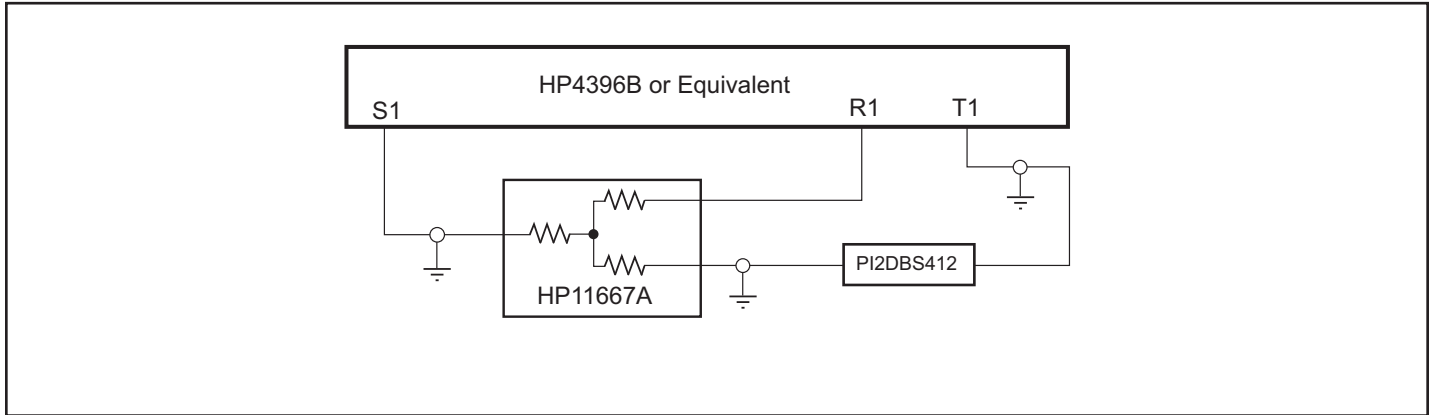
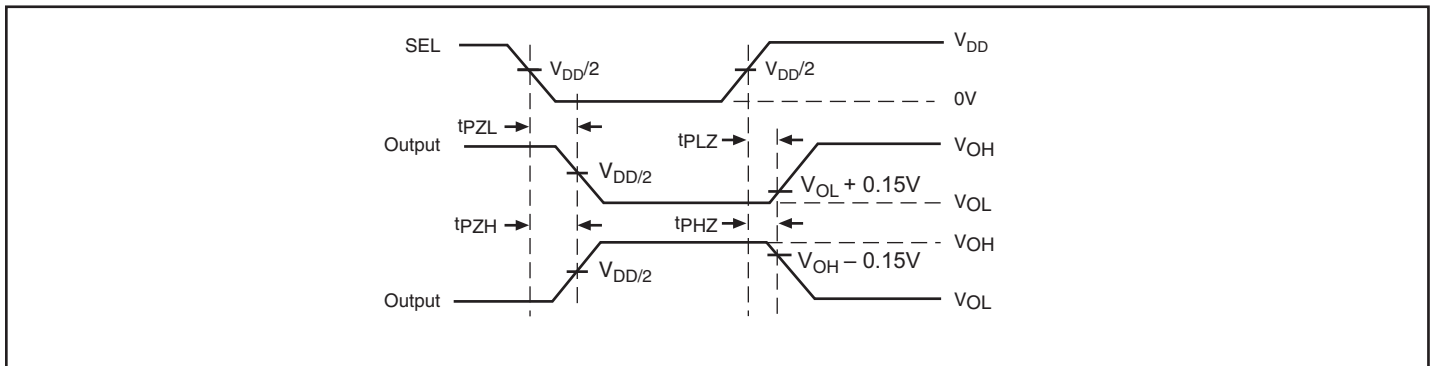
**Test Circuit for Dynamic Electrical Characteristics**

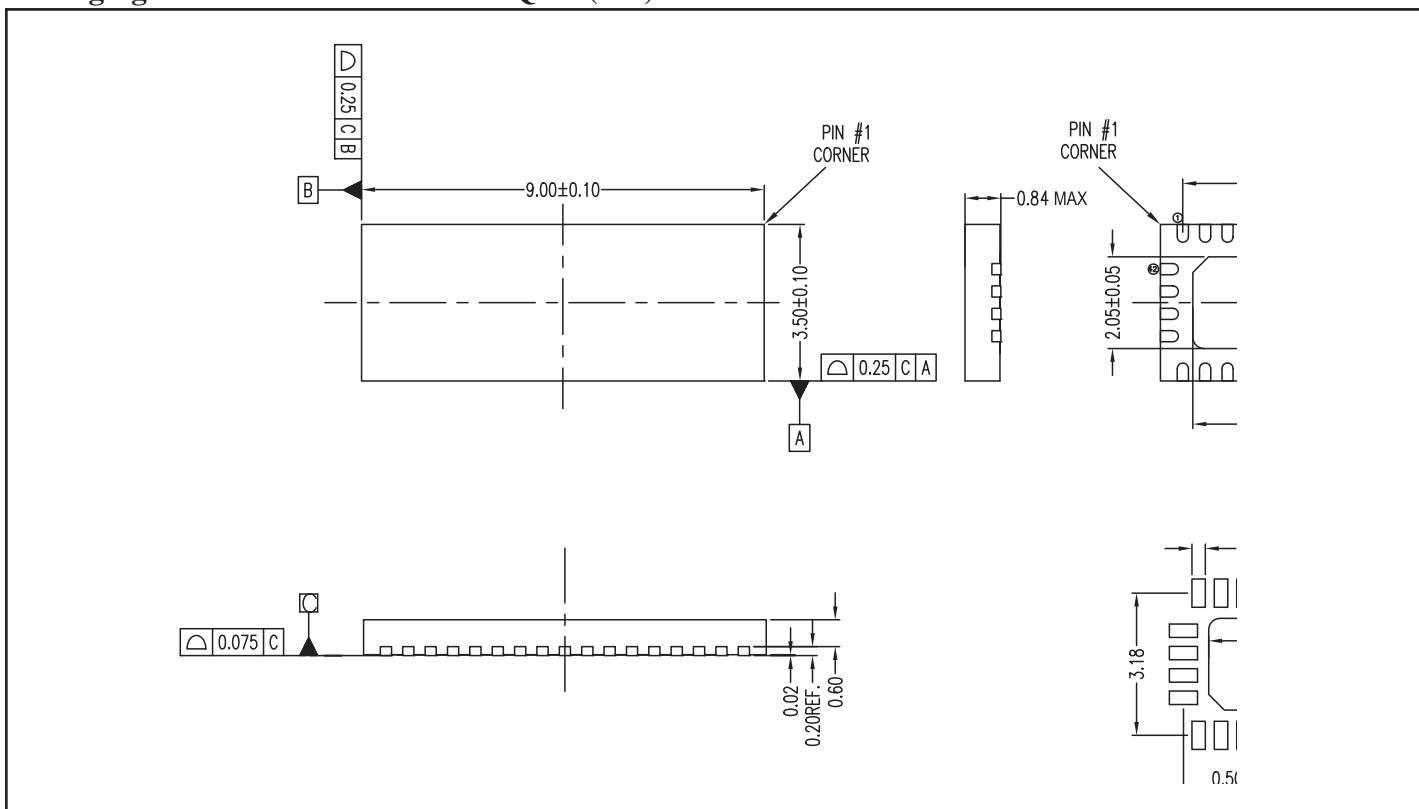
**Switching Waveforms**

**Voltage Waveforms Enable and Disable Times**

**Packaging Mechanical: 42-Contact TQFN (ZH)**

**Ordering Information**

Ordering Code	Package Code	Package Description
PI2DBS412ZHE	ZH	Pb-free & Green, 42-contact TQFN

**Notes:**

- Thermal characteristics can be found on the company web site at [www.pericom.com/packaging/](http://www.pericom.com/packaging/)
- E = Pb-free & Green
- Adding an X suffix = Tape/Reel