

μP Supervisory Circuit

Features

- User-Adjustable Low/High Thresholds with 585mV/615mV Internal Reference
- Low Current (1.5μA typ)
- Dual Low-Battery Outputs
- Push-Pull active low, Open-Drain active low and Open-Drain active high output options
- 90ms Minimum LBOA/LBOL Timeout Period
- Immune to Short Battery Voltage Transients
- -40°C to + 85°C Operating Temperature Range

Description

The PT7M7436/37/38 are dual-level battery monitors with internal hysteresis. These devices are offered with dual low-battery output indicators which can be used to indicate three battery conditions: good (operate system in normal mode), weak (operate system in low-power mode), or empty (disable the system).

Applications

- Monitoring lithiumion (Li⁺) cells or multicell alkaline/ NiCd/ NiMH power supplies.

Pin Configuration

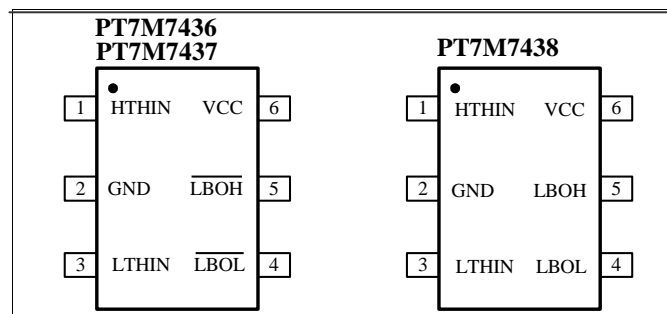

Pin Description

Pin	Name	Type	Description
1	HTHIN	I	HTH Threshold Monitor Input. A resistor-divider network sets the high threshold associated with $\overline{\text{LBOH}}/\text{LBOH}$.
2	GND	P	Ground
3	LTHIN	I	LTH Threshold Monitor Input. A resistor-divider network sets the low threshold associated with $\overline{\text{LBOL}}/\text{LBOL}$.
4	$\overline{\text{LBOL}}$ /LBOL	O	Low-Battery Output Low. $\overline{\text{LBOL}}/\text{LBOL}$ is asserted when LTHIN drops below $V_{\text{LTHIN-}}$. It remains asserted for at least 90ms after LTHIN rises above $V_{\text{LTHIN+}}$. Push-pull output for PT7M7436, open-drain output for PT7M7437/38.
5	$\overline{\text{LBOH}}$ /LBOH	O	Low-Battery Output High. $\overline{\text{LBOH}}/\text{LBOH}$ is asserted when HTHIN drops below $V_{\text{HTHIN-}}$. It remains asserted for at least 90ms after HTHIN rises above $V_{\text{HTHIN+}}$. Push-pull output for PT7M7436, open-drain output for PT7M7437/38.
6	VCC	P	Supply Voltage. Device power supply.

Maximum Ratings

Storage Temperature	-65°C to +150°C
Ambient Temperature with Power Applied.....	-40°C to +85°C
Supply Voltage to Ground Potential (V _{CC} to GND)	-0.3V to +7.0V
DC Input Voltage (All inputs except V _{CC} and GND).....	-0.3V to V _{CC} +0.3V
DC Output Current (All outputs)	20mA
Power Dissipation	320mW
	(Depend on package)

Note:

Stresses greater than those listed under MAXIMUM RATINGS may cause permanent damage to the device. This is a stress rating only and functional operation of the device at these or any other conditions above those indicated in the operational sections of this specification is not implied. Exposure to absolute maximum rating conditions for extended periods may affect reliability.

DC Electrical Characteristics

(V_{CC} = 1.8V to 5.5V, T_A = -40~85°C, unless otherwise noted. Typical values are at T_A = +25°C)

Description	Symbol	Test Conditions	Min	Typ	Max	Unit	
Operating Voltage Range	V _{CC}	T _A = -40~85°C	1.8	-	5.5	V	
V _{CC} Supply Current	I _{CC}	V _{CC} = 3.7V, no load, T _A = -40~85°C	-	1.5	2.5	μA	
Output High Voltage (Push-Pull only)	V _{OH}	V _{CC} ≥ 1.6V, I _{source} = 200μA	0.8×V _{CC}	-	-	V	
		V _{CC} ≥ 2.7V, I _{source} = 500μA	0.8×V _{CC}	-	-		
		V _{CC} ≥ 4.5V, I _{source} = 800μA	0.8×V _{CC}	-	-		
Output Low Voltage	V _{OL}	V _{CC} ≥ 1.6V, I _{sink} = 100μA	-	-	0.3	V	
		V _{CC} ≥ 2.7V, I _{sink} = 1.2mA	-	-	0.3		
		V _{CC} ≥ 4.5V, I _{sink} = 3.2mA	-	-	0.4		
Open-Drain Output Leakage Current	I _{LKG}	-	-	-	1	μA	
Input Leakage Current	I _{LKG}	V _{H_{THIN}} or V _{L_{THIN}} > 400mV	-	-	20	nA	
User-adjustable Thresholds (PT7M7436/37/38)							
HTHIN+ Threshold (Note 1)	V _{H_{THIN}+}	HTHIN rising, LBOH is deasserted when HTHIN rises above 615mV.	T _A = 25°C	-2	-	+2	%
			T _A = -10~85°C	-	100	-	ppm/°C
HTHIN- Threshold (Note 2)	V _{H_{THIN}-}	HTHIN falling, LBOH is asserted when HTHIN falls below V _{H_{THIN}-} . V _{REF} = 585mV	T _A = 25°C	-2	-	+2	%
			T _A = -10~85°C	-	100	-	ppm/°C
LTHIN+ Threshold (Note 1)	V _{L_{THIN}+}	LTHIN rising, LBOL is deasserted when LTHIN rises above V _{L_{THIN}+} . V _{REF} = 615mV	T _A = 25°C	-2	-	+2	%
			T _A = -10~85°C	-	100	-	ppm/°C
LTHIN- Threshold (Note 2)	V _{L_{THIN}-}	LTHIN falling, LBOL is asserted when LTHIN falls below V _{L_{THIN}-} . V _{REF} = 585mV	T _A = 25°C	-2	-	+2	%
			T _A = -10~85°C	-	100	-	ppm/°C

Note 1: Typical value is 615mV. Minimum and Maximum value is percentage of typical value.

Note 2: Typical value is 585mV. Minimum and Maximum value is percentage of typical value.

AC Electrical Characteristics

Fig 1. PT7M7436/37/38 timing diagram

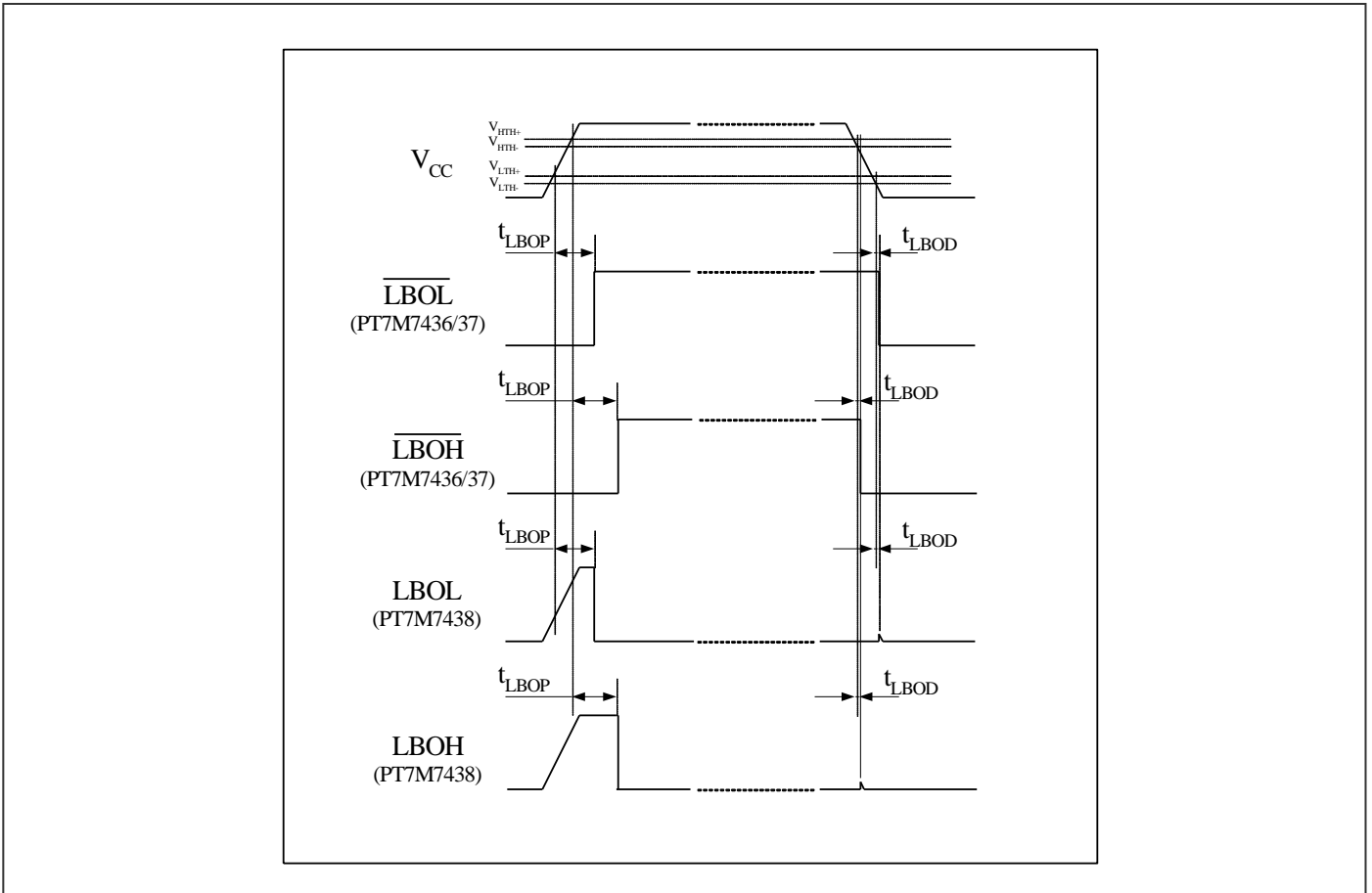

($V_{CC} = 1.8V$ to $5.5V$, $T_A = -40 \sim 85^\circ C$, unless otherwise noted. Typical values are at $T_A = +25^\circ C$)

Symbol	Description	Test Conditions	Min	Typ	Max	Unit
t_{LBOP}	Timeout period	-	90	200	350	ms
t_{LBOD}	Delay	-	-	100	-	μs

Block Diagram

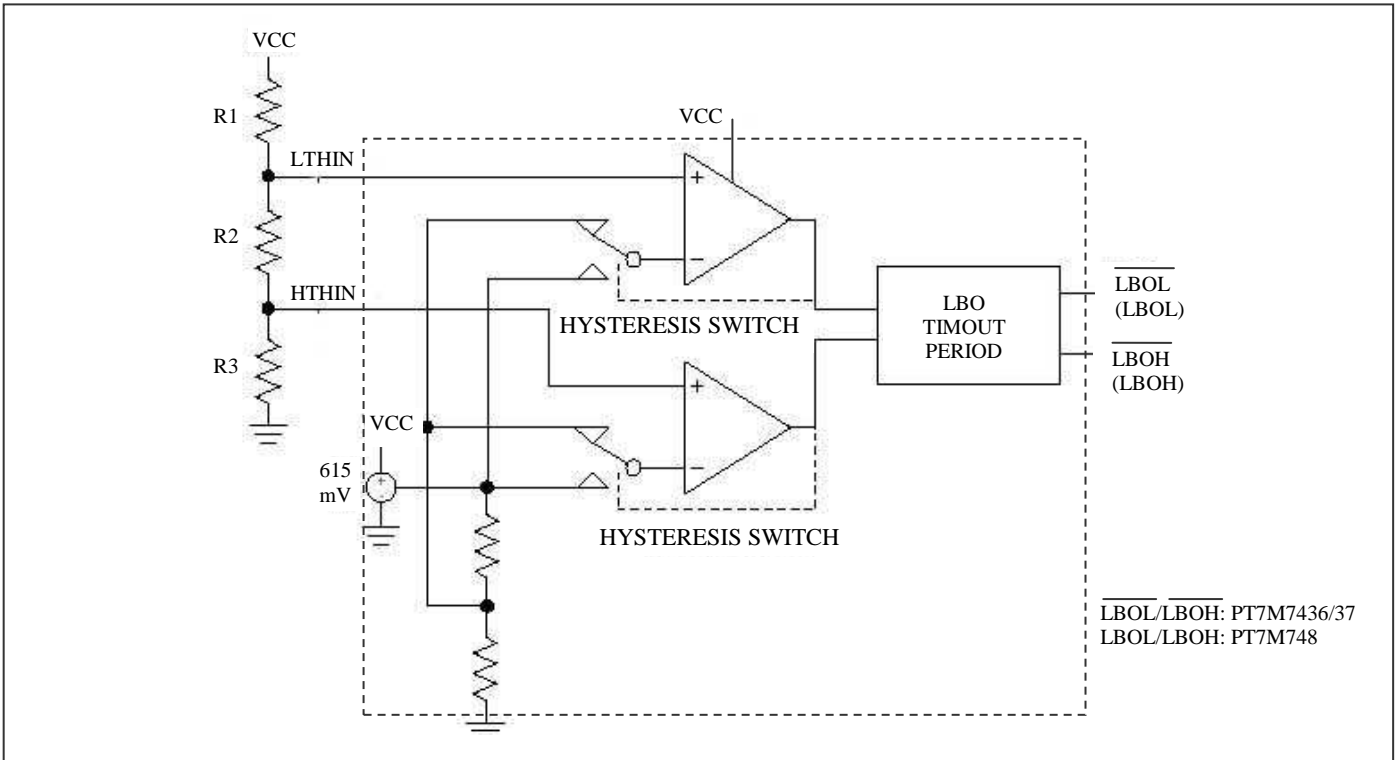

Function Description

The PT7M7436/37/38 are available with user adjustable monitoring.

The PT7M7436/37/38 combine a 585/615mV reference with two comparators, logic, and timing circuitry to provide the user with information about the charge state of the power-supply batteries. The PT7M7436/37/38 monitor separate high-voltage and low-voltage thresholds to determine battery status. The outputs can be used to signal when the battery is charged, when the battery is low, and when the battery is empty. PT7M7436/37/38 are also available with thresholds determined using an external resistor-divider (see Application information Resistor-Value Selection). They can monitor down to 0.62V, making them suitable for monitoring single-cell alkaline, NiMH, and NiCd applications ($V_{CC} \geq 1.8V$).

When the power-supply voltage drops below the specified low threshold, the low-battery output asserts (see Low-Battery Output). When the voltage rises above the specified high threshold following a 90ms (min) time-out period, the low-battery output is deasserted (see Threshold Monitoring). This ensures the supply voltage has stabilized before power-converter or microprocessor activity is enabled.

Low-Battery Output

The low-battery outputs are available in active-low (\overline{LBOH} , \overline{LBOL} push-pull and open drain) and active-high (LBOH, LBOL open drain) configurations. Push-pull outputs are referenced to V_{CC} .

The open-drain devices can be pulled to a voltage independent of V_{CC} , up to 5.5V. This allows the device to monitor and operate from direct battery voltage while interfacing to higher voltage microprocessors.

The PT7M7436/37/38 dual-output voltage monitors provide two low-battery outputs, \overline{LBOH} /LBOH and \overline{LBOL} /LBOL. They will assert \overline{LBOH} /LBOH when HTHIN drops below V_{HTHIN-} , and assert \overline{LBOL} /LBOL when LTHIN drops below V_{LTHIN-} .

Threshold Monitoring

The PT7M7436/37/38 dual-output voltage monitors assert \overline{LBOL} /LBOL when LTHIN drops below the LTHIN-threshold and deassert \overline{LBOL} /LBOL when LTHIN rises above the LTHIN+ threshold for at least 90ms. \overline{LBOH} /LBOH is asserted when HTHIN drops below the HTHIN- threshold and is deasserted when HTHIN rises above the HTHIN+ threshold for at least 90ms (see AC Electrical Characteristics: Fig 1).

Hysteresis

Hysteresis increases the comparator's noise margin by increasing the upper threshold or decreasing the lower threshold. The hysteresis prevents the output from oscillating (chattering) when V_{CC} is near the low-battery threshold. This is especially important for applications where the load on the battery creates significant fluctuations in battery voltages. The hysteresis for the PT7M7436/37/38 is the differences between V_{HTHIN-} and V_{HTHIN+} (≈ 1.05) or V_{LTHIN-} and V_{LTHIN+} (≈ 1.05).

Application Information

Resistor-Value Selection (Programming the Adjustable Thresholds)

$$V_{REF} = V_{LTH-} = V_{HTH-} = 585mV$$

$$V_{TRIPLOW} = V_{LTH-} = V_{REF} \left(\frac{R1 + R2 + R3}{R2 + R3} \right)$$

$$V_{TRIPHIGH} = V_{HTL-} = V_{REF} \left(\frac{R1 + R2 + R3}{R3} \right)$$

$$R_{TOTAL} = R1 + R2 + R3$$

Use the following steps to determine values for R1, R2, and R3 of Functional Block Diagram.

- 1) Choose a value for R_{TOTAL} , the sum of R1, R2, and R3.
Because the PT7M7436~PT7M7438 have very high input impedances, R_{TOTAL} can be up to 5MΩ.

- 2) Calculate R3 based on R_{TOTAL} and the desired upper trip point:

$$R3 = \frac{V_{REF} \times R_{TOTAL}}{V_{TRIPHIGH}} = \frac{585mV \times R_{TOTAL}}{V_{TRIPHIGH}}$$

- 3) Calculate R2 based on R_{TOTAL} , R3, and the desired lower trip point:

$$R2 = \frac{585mV \times R_{TOTAL}}{V_{TRIPLOW}} - R3$$

- 4) Calculate R1 based on R_{TOTAL} , R3, and R2:

$$R1 = R_{TOTAL} - R2 - R3$$

$$V_{HTH+} = V_{HTH-} \times 1.05, V_{LTH+} = V_{LTH-} \times 1.05$$

Mechanical Information

TAE (SOT23-6)

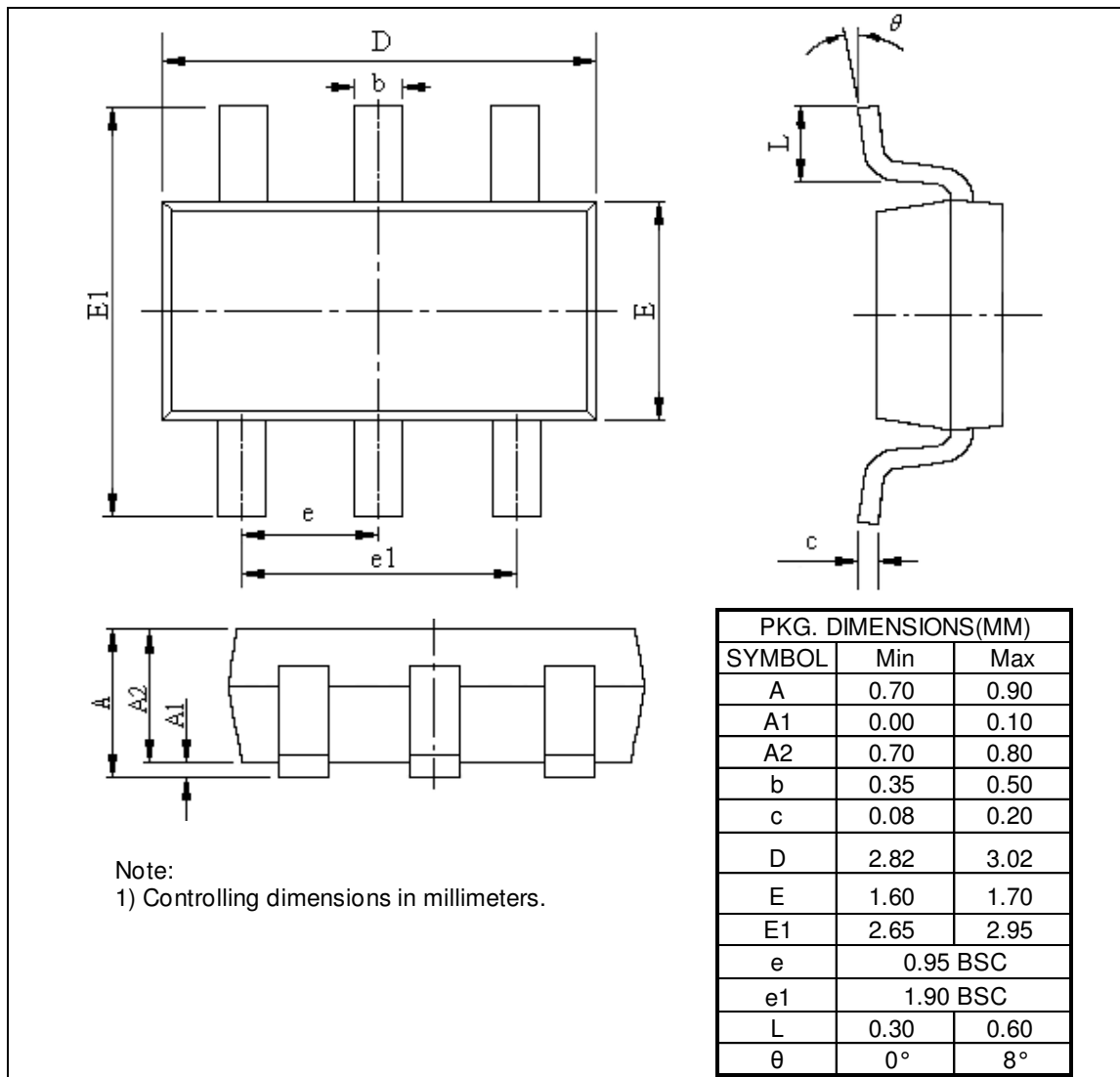

Ordering Information

Part Number	Package Code	Package	Marking Code
PT7M7436TAE	TA	lead-free and Green SOT23-6	MP
PT7M7437TAE	TA	Lead-free and Green SOT23-6	fN
PT7M7438TAE	TA	lead-free and Green SOT23-6	MR

Note:

- E = Pb-free and Green
- Adding X Suffix= Tape/Reel

SOT-23 Package Top Marking Instruction

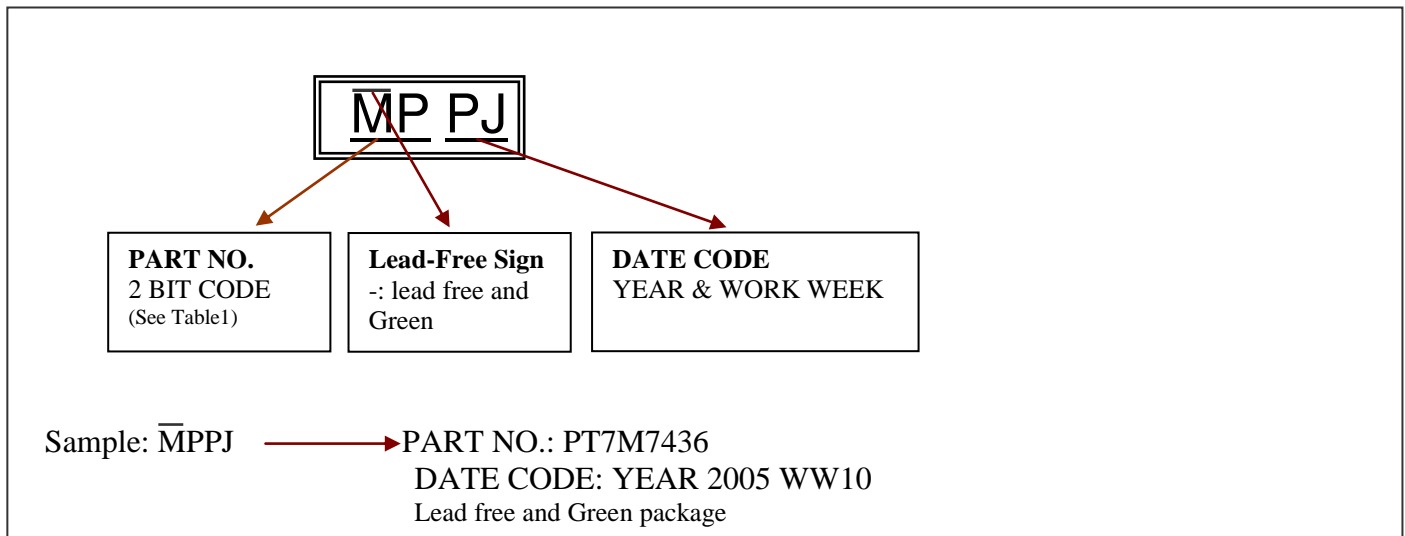

1. Package Type: SOT-23
2. Package Code: TA
3. 2005-Year Code: P
4. Work Week Code: WW7-G WW8-H WW9-I WW10-J WW11-K WW12-L
 WW13-M WW14-N WW15-O WW16-P WW17-Q
5. Font Style: HELVETICA or ARIAL
6. Max Characters Per Line (Only 1 line): 4
7. Max Characters Height: 0.8 mm
8. Min Characters Height: 0.6 mm
9. Max Characters Width: 0.6 mm
10. Mark Placement: Center

Table 1. Function comparison of PT7M7436/37/38

Item	Part No.	Output				Threshold		
		Open-Drain		Push-Pull	Single	Dual	Factory fixed	User adjustable
		Active high	Active low	Active low				
1	PT7M7436	-	-	√	-	√	-	√
2	PT7M7437	-	√	-	-	√	-	√
3	PT7M7438	√	-	-	-	√	-	√

Pericom Semiconductor Corporation • 1-800-435-2336 • www.pericom.com

Pericom reserves the right to make changes to its products or specifications at any time, without notice, in order to improve design or performance and to supply the best possible product. Pericom does not assume any responsibility for use of any circuitry described other than the circuitry embodied in Pericom product. The company makes no representations that circuitry described herein is free from patent infringement or other rights, of Pericom.