

## Supervisory Circuit

### Features

- Highly accurate:  $\pm 1.5\%$  ( $25^{\circ}\text{C}$ )
- Detect voltage range: 1.8 to 5V in 100mV increments
- Operating voltage range: 1.0V ~ 5.5V
- Operating temperature range:  $-40^{\circ}\text{C}$  to  $+85^{\circ}\text{C}$
- Detect voltage temperature characteristics:  $\pm 2.5\% \times \text{TYP}$
- Output configuration: N-channel open drain
- Three reset timeout period available:
  - ♦ typical 1.6ms for PT7M6315USxxD1;
  - ♦ typical 26ms for PT7M6315USxxD2;
  - ♦ typical 200ms for PT7M6315USxxD3;
  - ♦ typical 1570ms for PT7M6315USxxD4;

### Description

The series are designed to monitor power supplies in  $\mu\text{P}$  and digital systems. It provides excellent circuit reliability and low cost by eliminating external components and adjustments, and a debounced manual reset input.

This device performs a single function: it asserts a reset signal whenever the  $V_{\text{CC}}$  supply voltage falls below a preset threshold or whenever manual reset is asserted. Reset remains asserted for an internally programmed interval (reset timeout period) after  $V_{\text{CC}}$  has risen above the reset threshold or manual reset is deasserted.

The PT7M6315USxx are open-drain RESET output. They can be pulled up to a voltage higher than  $V_{\text{CC}}$ .

The serials come with factory-trimmed reset threshold voltages in 100mV increments from 1.8V to 5V. Preset timeout periods of 200ms (typ.) for PT7M6315USxxD3, 1570ms (typ.) for PT7M6315USxxD4, and 26ms for PT7M6315USxxD2 are available.

### Pin Configuration

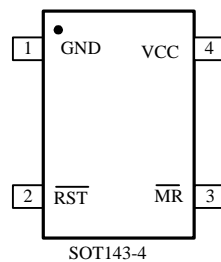

### Pin Description

Name	Type	Description
$\overline{\text{RST}}$	I/O	<b>Reset Output:</b> $\overline{\text{RST}}$ is asserted when $V_{\text{CC}}$ drops below voltage threshold $V_{\text{TH}}$ . Active low.
$\overline{\text{MR}}$	I	<b>Manual Reset:</b> A logic low on $\overline{\text{MR}}$ asserts reset. Reset remains asserted as long as $\overline{\text{MR}}$ is low, and for the reset timeout period ( $t_{\text{RS}}$ ) after the reset conditions are terminated. Connect to $V_{\text{CC}}$ if not used.
GND	P	<b>Ground</b>
$V_{\text{CC}}$	P	<b>Supply Voltage.</b>

## Block Diagram

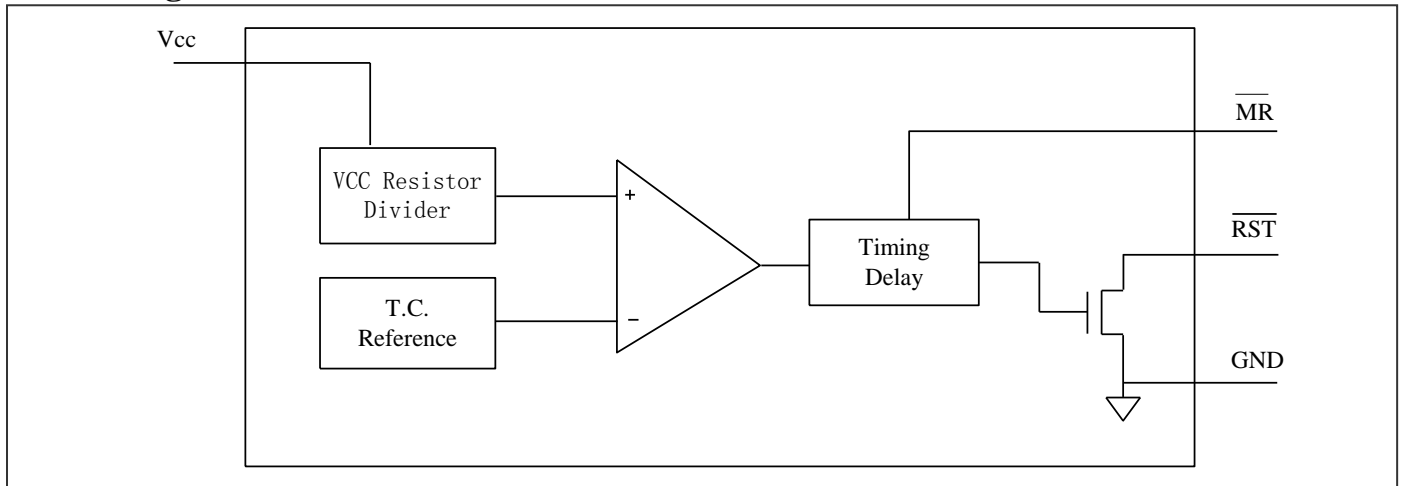

## Function Description

### Power Monitor

A microprocessor's ( $\mu\text{P}$ 's) reset input starts the  $\mu\text{P}$  in a known state. Whenever the  $\mu\text{P}$  is in an unknown state, it should be held in reset. The supervisory circuits assert reset during power-up and prevent code execution errors during power-down or brownout conditions.

On power-up, once Vcc reaches about 1.0V,  $\overline{\text{RST}}$  is a guaranteed logic low of 0.4V or less. As Vcc rises,  $\overline{\text{RST}}$  stays low. When Vcc rises above the reset threshold  $V_{\text{RST}}$ , an internal timer releases  $\overline{\text{RST}}$  after about 200ms (PT7M6315USxxD3) or 1570ms (PT7M6315USxxD4) or 26ms (PT7M6315USxxD2) or 1.6ms (PT7M6315USxxD1). RST asserts whenever Vcc drops below the reset threshold, i.e. brownout condition. If brownout occurs in the middle of a previously initiated reset pulse, the pulse continues for at least another 200ms (PT7M6315USxxD3) or 1570ms (PT7M6315USxxD4) or 26ms (PT7M6315USxxD2) or 1.6ms (PT7M6315USxxD1). On power-down, once Vcc falls below the reset threshold, RST stays low and is guaranteed to be 0.4V or less until Vcc drops below 1V.

### Manual Reset

The manual-reset input ( $\overline{\text{MR}}$ ) allows reset to be triggered by a pushbutton switch. The switch is effectively debounced by the 1.6ms (PT7M6315USxxD1) or 26ms (PT7M6315USxxD2) or 200ms (PT7M6315USxxD3) or 1570ms (PT7M6315USxxD4) reset pulse width.

## Maximum Ratings

Storage Temperature .....	-65°C to +150°C
Ambient Temperature with Power Applied .....	-40°C to +85°C
Supply Voltage to Ground Potential (V <sub>CC</sub> to GND) .....	-0.3V to +7.0V
DC Input Voltage (All inputs except V <sub>CC</sub> and GND).....	-0.3V to V <sub>CC</sub> +0.3V
DC Output Current (All outputs) .....	30mA
Power Dissipation .....	320mW (Depend on package)

**Note:**

Stresses greater than those listed under MAXIMUM RATINGS may cause permanent damage to the device. This is a stress rating only and functional operation of the device at these or any other conditions above those indicated in the operational sections of this specification is not implied. Exposure to absolute maximum rating conditions for extended periods may affect reliability.

## DC Electrical Characteristics

(T<sub>A</sub>= -40~85°C, unless otherwise noted. Typical values are at T<sub>A</sub> = +25°C)

Description		Sym.	Test Conditions	Min	Typ	Max	Unit
Supply Voltage		V <sub>CC</sub>	-	1.0	-	5.5	V
Supply Current		I <sub>CC</sub>	V <sub>CC</sub> = 5.5V. No load.	-	-	12	μA
			V <sub>CC</sub> = 3.6V. No load.	-	-	10	μA
Voltage Threshold		V <sub>TH-</sub>	+25°C	(V <sub>TH-</sub> ) ×0.985	V <sub>TH-</sub>	(V <sub>TH-</sub> ) ×1.015	V
			-40°C~85°C	(V <sub>TH-</sub> ) ×0.975	V <sub>TH-</sub>	(V <sub>TH-</sub> ) ×1.025	
Hysteresis		V <sub>HYS</sub>	V <sub>TH+</sub> - V <sub>TH-</sub> *	-	50	-	mV
Output Driving	Output low	V <sub>OL</sub>	I <sub>OH</sub> = 8mA, V <sub>CC</sub> = 5V	-	-	0.4	V
			I <sub>OH</sub> = 4mA, V <sub>CC</sub> = 3V	-	-	0.3	
			I <sub>OH</sub> = -50μA, V <sub>CC</sub> = 1V	-	-	0.09	
Open-Drain Output Leakage Current		I <sub>LKG</sub>	-	-	-	500	nA
Internal pull-up resistor		R <sub>P</sub>	$\overline{MR}$	32	63	100	kΩ
Input High Voltage		V <sub>IH</sub>	$\overline{MR}$	V <sub>CC</sub> < 4V	0.7×V <sub>CC</sub>	-	V
				V <sub>CC</sub> > 4V	2.4	-	
Input Low Voltage		V <sub>IL</sub>	$\overline{MR}$	V <sub>CC</sub> < 4V	-	0.3×V <sub>CC</sub>	V
				V <sub>CC</sub> > 4V	-	-	

**Note:** V<sub>TH-</sub> is voltage threshold when V<sub>CC</sub> falls from high to low. V<sub>TH+</sub> is voltage threshold when V<sub>CC</sub> rises from low to high.

## AC Electrical Characteristics

### Timing diagram

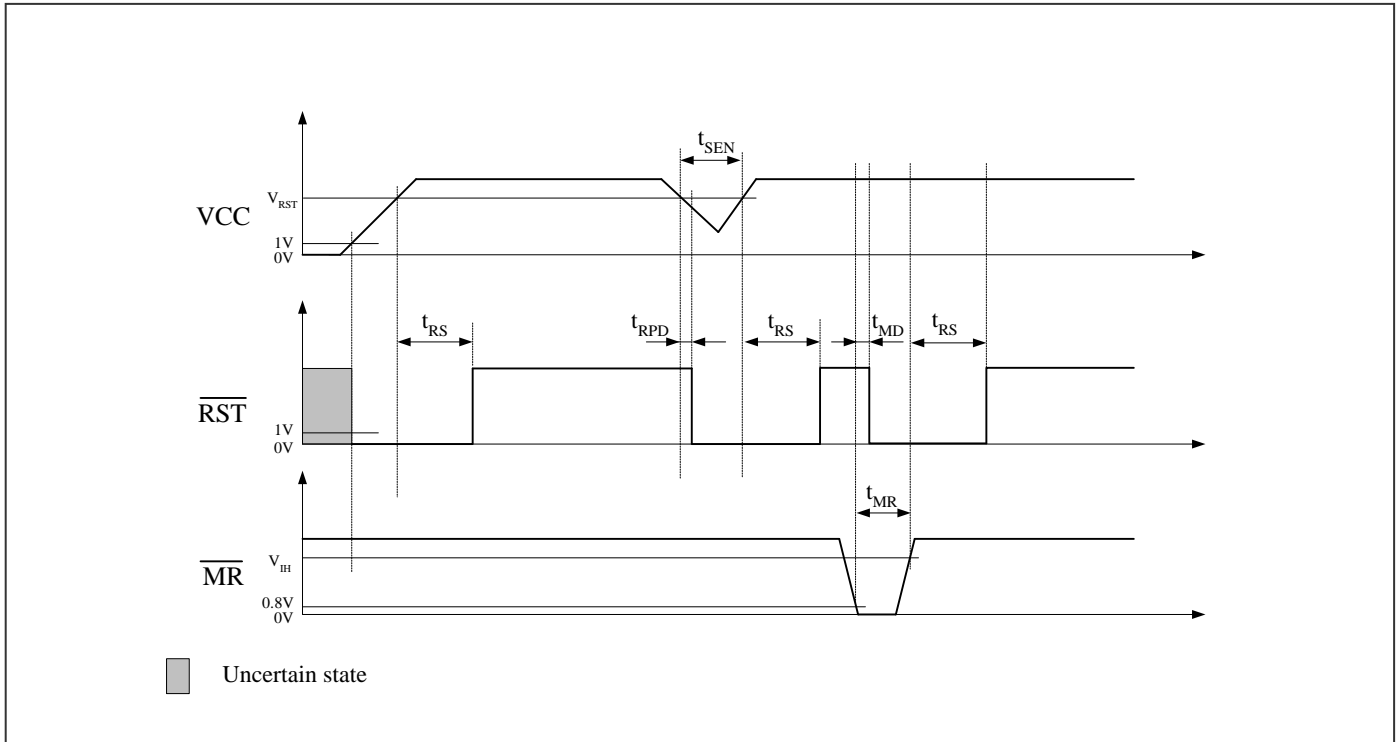

( $V_{CC} = 1.0V$  to  $5.5V$ ,  $T_A = -40 \sim 85^\circ C$ , unless otherwise noted. Typical values are at  $T_A = +25^\circ C$ )

Sym.	Description	Test Conditions	Part No.	Min	Typ	Max	Unit
$t_{RS}$	Reset Timeout Period	-	6315USxxD1	1	1.6	2.2	ms
		-	6315USxxD2	17	26	40	ms
		-	6315USxxD3	140	200	280	ms
		-	6315USxxD4	1120	1570	2240	ms
$t_{RPD}$	Delay	-	-	17	-	$\mu s$	
$t_{SEN}$	Sensitivity	-	-	20	-	$\mu s$	
$t_{MD}$	$\overline{MR}$ to Reset Delay	-	-	-	500	-	ns
$t_{MR}$	$\overline{MR}$ Pulse Width	-	-	1	-	-	$\mu s$

**Mechanical Information**

SOT143-4

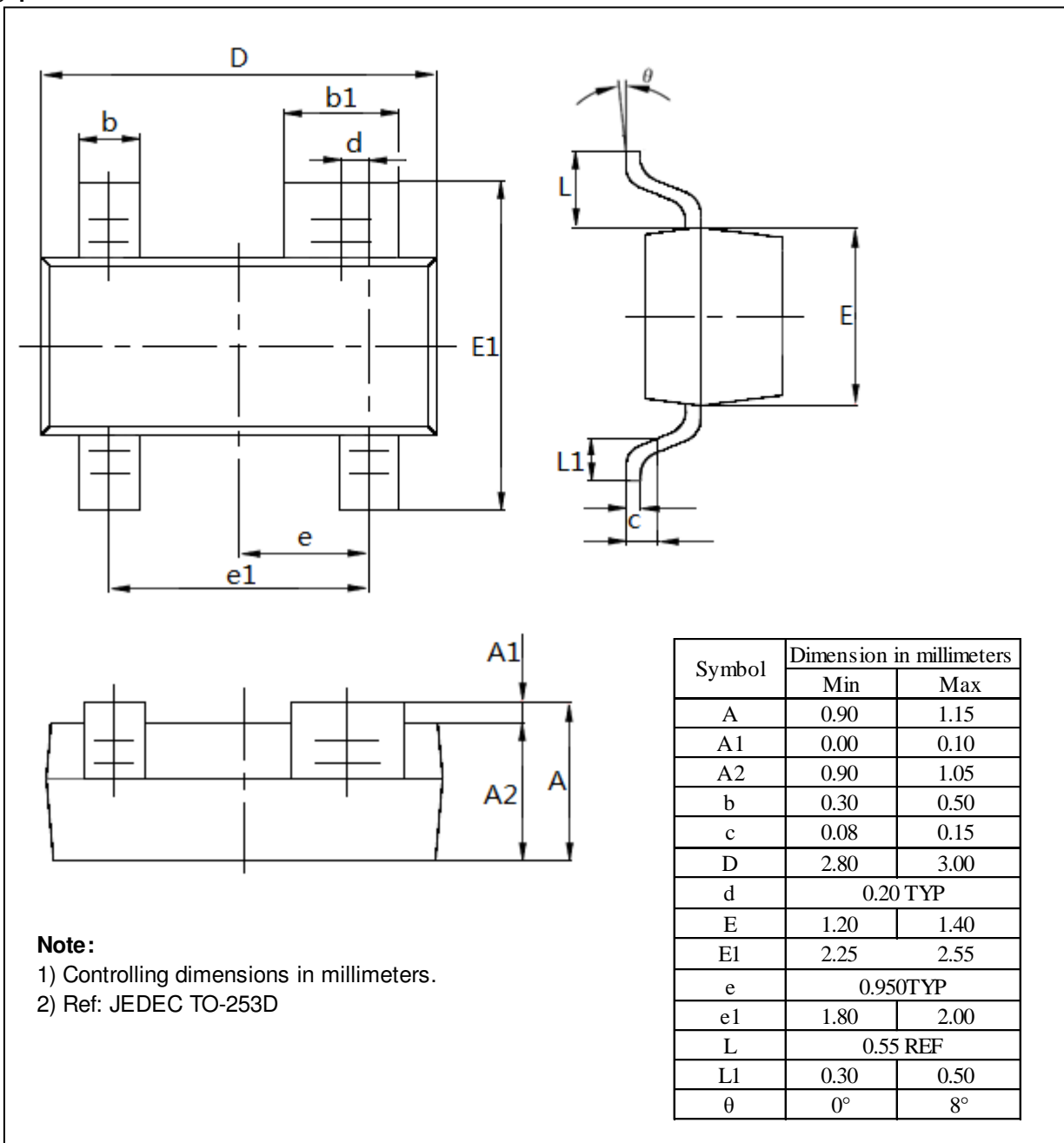
**Ordering Information**

Part Number	Package Code	Package
PT7M6315USxxD3TBE	TB	Lead free and Green SOT143-4
PT7M6315USxxD4TBE	TB	Lead free and Green SOT143-4
PT7M6315USxxD2TBE	TB	Lead free and Green SOT143-4
PT7M6315USxxD1TBE	TB	Lead free and Green SOT143-4

**Note:**

- “xx” refer to voltage range, see below table 1.
- E=Lead-free and Green Packaging
- Adding X suffix=Tape/Reel
- Contact Pericom for availability.

**Table 1. Suffix “xx” definition of PT7M6315USxx**

Suffix xx	V <sub>TH</sub> (V)	Suffix xx	V <sub>TH</sub> (V)	Suffix xx	V <sub>TH</sub> (V)	Suffix xx	V <sub>TH</sub> (V)
18	1.8	27	2.7	36	3.6	45	4.5
19	1.9	28	2.8	37	3.7	46	4.6
20	2.0	29	2.9	38	3.8	47	4.7
21	2.1	30	3.0	39	3.9	48	4.8
22	2.2	31	3.1	40	4.0	49	4.9
23	2.3	32	3.2	41	4.1	50	5.0
24	2.4	33	3.3	42	4.2		
25	2.5	34	3.4	43	4.3		
26	2.6	35	3.5	44	4.4		

### SOT-143 Package Top Marking Instruction

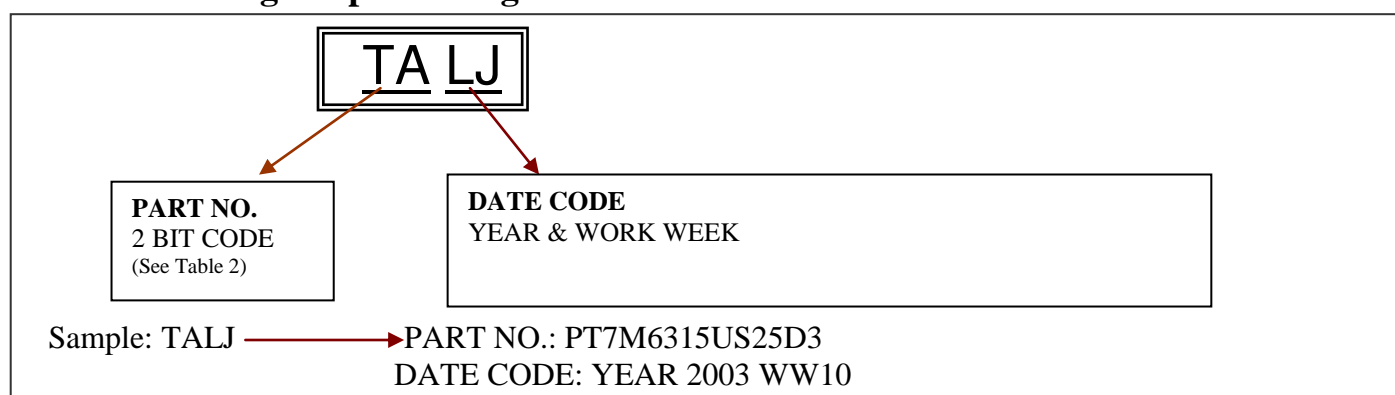
**Table 2 Product Marking Code**

Part No.	Code	Part No.	Code	Part No.	Code
PT7M6315US25D3	TA	PT7M6315US34D3	UK	PT7M6315US43D3	VU
PT7M6315US25D4	TB	PT7M6315US34D4	UL	PT7M6315US43D4	VV
PT7M6315US26D3	TE	PT7M6315US35D3	UO	PT7M6315US44D3	VY
PT7M6315US26D4	TF	PT7M6315US35D4	UP	PT7M6315US44D4	VZ
PT7M6315US27D3	TI	PT7M6315US36D3	US	PT7M6315US45D3	WC
PT7M6315US27D4	TJ	PT7M6315US36D4	UT	PT7M6315US45D4	WD
PT7M6315US28D3	TM	PT7M6315US37D3	UW	PT7M6315US46D3	WG
PT7M6315US28D4	TN	PT7M6315US37D4	UX	PT7M6315US46D4	WH
PT7M6315US29D3	TQ	PT7M6315US38D3	VA	PT7M6315US47D3	WK
PT7M6315US29D4	TR	PT7M6315US38D4	VB	PT7M6315US47D4	WL
PT7M6315US30D3	TU	PT7M6315US39D3	VE	PT7M6315US48D3	WO
PT7M6315US30D4	TV	PT7M6315US39D4	VF	PT7M6315US48D4	WP
PT7M6315US31D3	TY	PT7M6315US40D3	VI	PT7M6315US49D3	WS
PT7M6315US31D4	TZ	PT7M6315US40D4	VJ	PT7M6315US49D4	WT
PT7M6315US32D3	UC	PT7M6315US41D3	VM	PT7M6315US50D3	WW
PT7M6315US32D4	UD	PT7M6315US41D4	VN	PT7M6315US50D4	WX
PT7M6315US33D3	UG	PT7M6315US42D3	VQ	PT7M6315US29D2	pM
PT7M6315US33D4	UH	PT7M6315US42D4	VR	PT7M6315US30D2	pN

Pericom Semiconductor Corporation • 1-800-435-2336 • [www.pericom.com](http://www.pericom.com)

Pericom Technology Incorporation reserves the right to make changes to its products or specifications at any time, without notice, in order to improve design or performance and to supply the best possible product. Pericom Technology does not assume any responsibility for use of any circuitry described other than the circuitry embodied in Pericom Technology product. The company makes no representations that circuitry described herein is free from patent infringement or other rights, of Pericom Technology Incorporation.