

Supervisory Circuit
Features

- Highly accurate: $\pm 1.5\%$ (25°C)
- Detect voltage range: 1.8 to 5V in 100mV increments
- Operating voltage range: 1.0V ~ 5.5V
- Operating temperature range: -40°C to $+85^{\circ}\text{C}$
- Detect voltage temperature characteristics: $\pm 2.5\% \times \text{TYP}$
- Output configuration: Bi-dir
- Two reset timeout period available: typical 200ms and 1570ms (for PT7M6314USxxD4 only)

General Description

The series are designed to monitor power supplies in μP and digital systems. It provides excellent circuit reliability and low cost by eliminating external components and adjustments, and a debounced manual reset input.

This device performs a single function: it asserts a reset signal whenever the V_{CC} supply voltage falls below a preset threshold or whenever manual reset is asserted. Reset remains asserted for an internally programmed interval (reset timeout period) after V_{CC} has risen above the reset threshold or manual reset is deasserted.

PT7M6314USxx are bidirectional output, allowing it to be directly connected to μP with bidirectional reset inputs. The serials come with factory-trimmed reset threshold voltages in 100mV increments from 2.5V to 5V. Preset timeout periods of 200ms and 1570ms (typ.) are available.

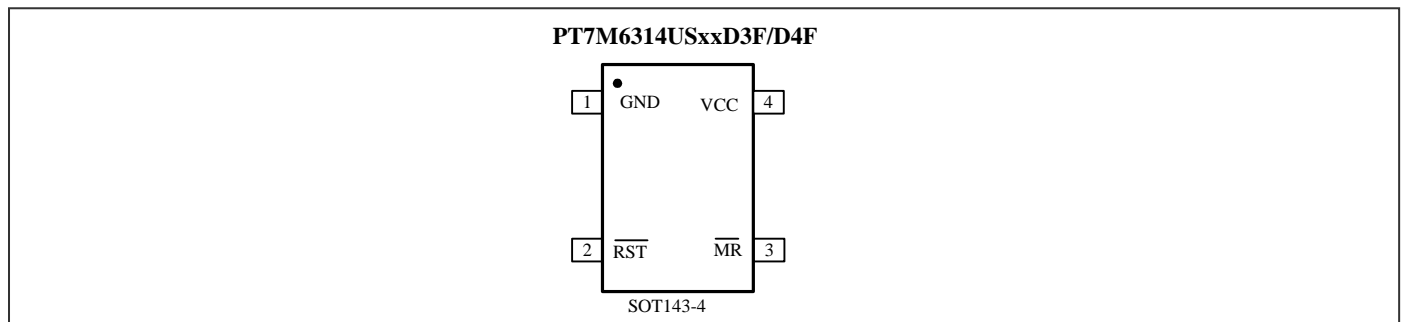
Pin Configuration

Pin Description

Name	Type	Description
$\overline{\text{RST}}$	I/O	Reset Output and Pushbutton Input: $\overline{\text{RST}}$ is asserted when V_{CC} drops below voltage threshold V_{TH} . Active low. When other devices pull $\overline{\text{RST}}$ low, the device will speed its rising edge once the reset condition release.
$\overline{\text{MR}}$	I	Manual Reset: A logic low on $\overline{\text{MR}}$ asserts reset. Reset remains asserted as long as $\overline{\text{MR}}$ is low, and for the reset timeout period (t_{RS}) after the reset conditions are terminated. Connect to V_{CC} if not used.
GND	P	Ground
V_{CC}	P	Supply Voltage.

Maximum Ratings

Storage Temperature	-65°C to +150°C
Ambient Temperature with Power Applied	-40°C to +85°C
Supply Voltage to Ground Potential (V _{CC} to GND)	-0.3V to +7.0V
DC Input Voltage (All inputs except V _{CC} and GND).....	-0.3V to V _{CC} +0.3V
DC Output Current (All outputs)	30mA
Power Dissipation	320mW (Depend on package)

Note:

Stresses greater than those listed under MAXIMUM RATINGS may cause permanent damage to the device. This is a stress rating only and functional operation of the device at these or any other conditions above those indicated in the operational sections of this specification is not implied. Exposure to absolute maximum rating conditions for extended periods may affect reliability.

DC Electrical Characteristics

(T_A = -40~85°C, unless otherwise noted. Typical values are at T_A = +25°C)

Description		Sym.	Test Conditions	Part No	Min	Typ	Max	Unit
Supply Voltage		V _{CC}			1.0		5.5	V
Supply Current		I _{CC}	V _{CC} = 5.5V. No load.				12	μA
			V _{CC} = 3.6V. No load.				10	μA
Voltage Threshold		V _{TH-}	+25°C		(V _{TH-}) ×0.985	V _{TH-}	(V _{TH-}) ×1.015	V
			-40°C~85°C		(V _{TH-}) ×0.975	V _{TH-}	(V _{TH-}) ×1.025	
Hysteresis		V _{HYS}	V _{TH+} - V _{TH-} *			50		mV
Output Driving	Output low	V _{OL}	I _{OH} = 8mA, V _{CC} = 5V				0.4	V
			I _{OH} = 4mA, V _{CC} = 3V				0.3	
			I _{OH} = -50μA, V _{CC} = 1V				0.09	
Internal pull-up resistor		R _P	$\overline{\text{MR}}$		32	63	100	kΩ
			$\overline{\text{RST}}$ pin. V _{CC} = 3V.		3.75	5	6.25	kΩ
Input High Voltage		V _{IH}	$\overline{\text{MR}}$	V _{CC} < 4V		0.7×V _{CC}		V
				V _{CC} > 4V		2.4		
Input Low Voltage		V _{IL}	$\overline{\text{MR}}$	V _{CC} < 4V			0.3×V _{CC}	V
				V _{CC} > 4V			0.8	
$\overline{\text{RST}}$ active pull-up enable threshold		V _{THUP}	V _{CC} = 5V		0.7	0.9	1.2	V
$\overline{\text{RST}}$ active pull-up current			V _{CC} = 3.3V			20		mA

Note: V_{TH-} is voltage threshold when V_{CC} falls from high to low. V_{TH+} is voltage threshold when V_{CC} rises from low to high.

AC Electrical Characteristics
Timing diagram

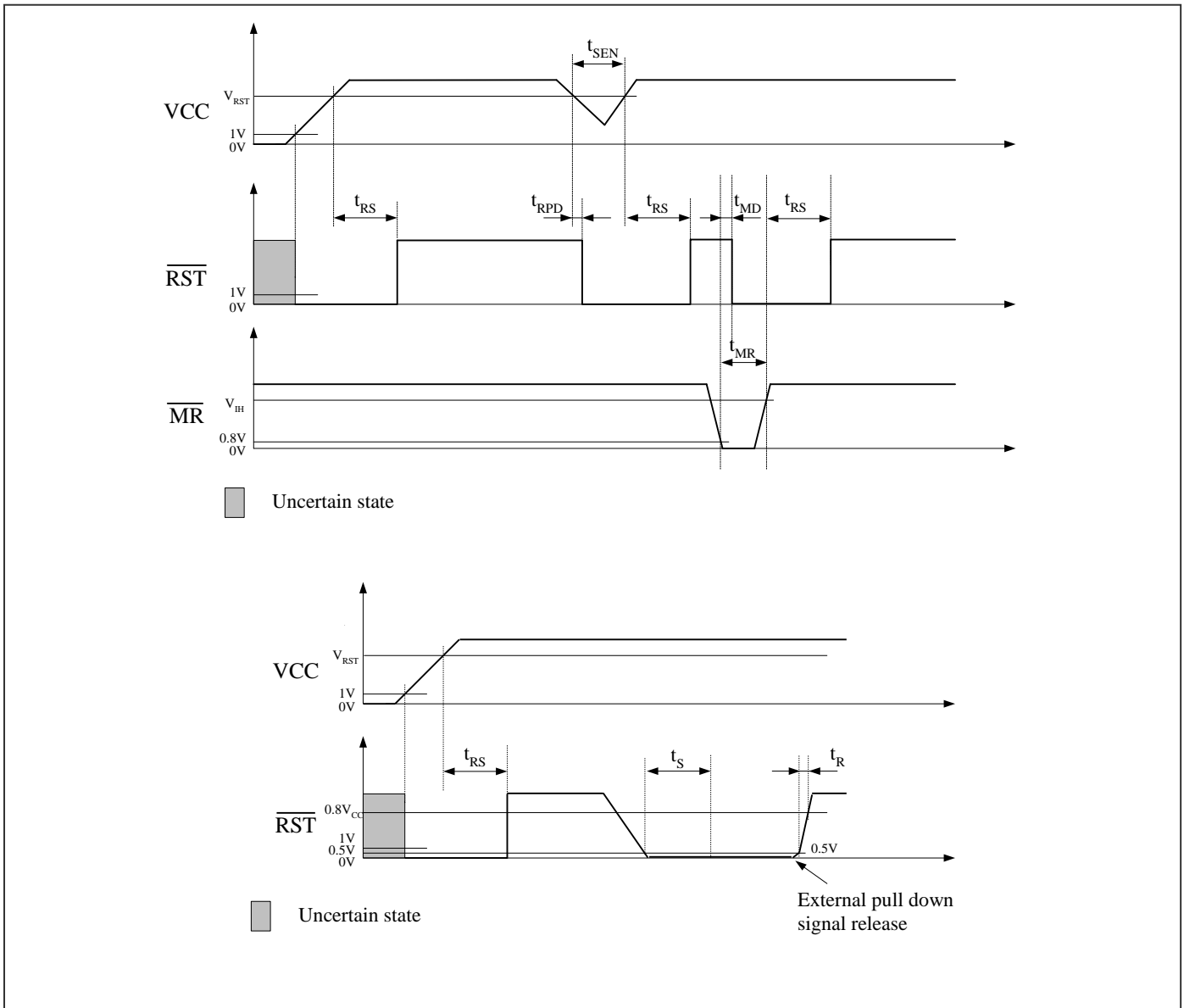

(V_{CC} = 1.0V to 5.5V, T_A = -40~85°C, unless otherwise noted. Typical values are at T_A = +25°C)

Sym.	Description	Test Conditions	Part No.	Min	Typ	Max	Unit
t _{RS}	Reset Timeout Period		6314USxxD3	140	200	280	ms
			6314USxxD4	1120	1570	2240	ms
t _{RPD}	Delay				10		ns
t _{SEN}	Sensitivity			20			μs
t _{MD}	MR to Reset Delay				500		ns
t _{MR}	MR Pulse Width			1			μs
t _{PD}	External Pull Down Signal Pulse	RST pin		1			μs
t _R	RST Output Rise Time	V _{CC} = 3V	C _{LOAD} = 120pF			333	ns
			C _{LOAD} = 250pF			666	
		V _{CC} = 5V	C _{LOAD} = 200pF			333	
			C _{LOAD} = 400pF			666	

Block Diagram

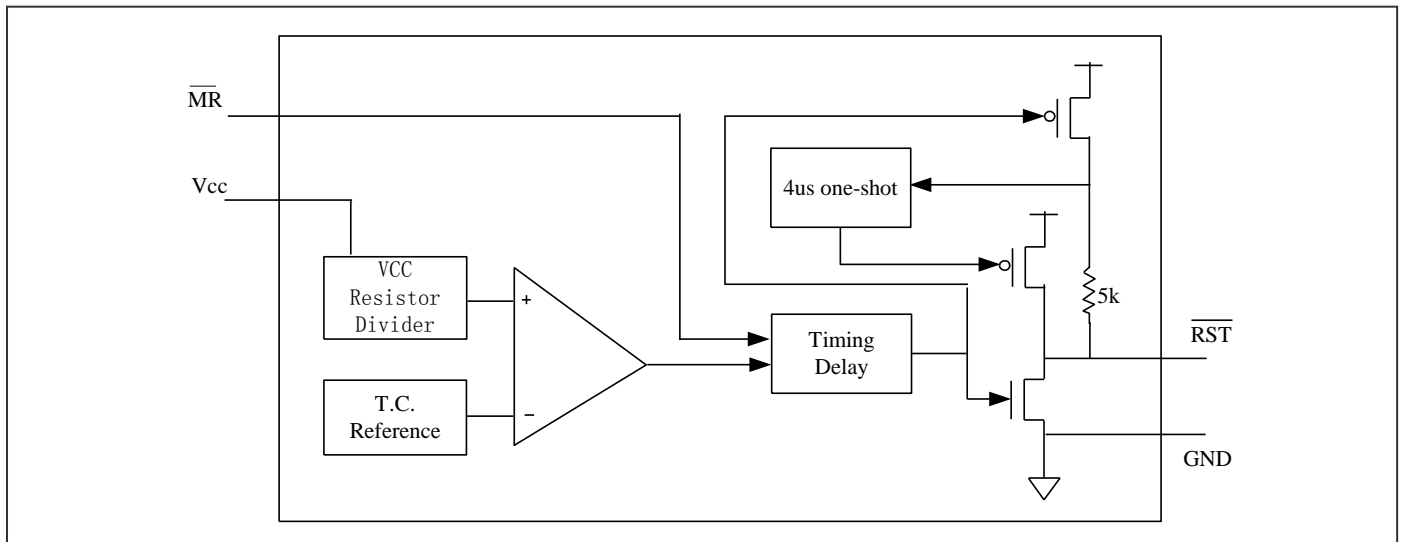

Function Description

Power Monitor

A microprocessor's (μP 's) reset input starts the μP in a known state. Whenever the μP is in an unknown state, it should be held in reset. The supervisory circuits assert reset during power-up and prevent code execution errors during power-down or brownout conditions.

On power-up, once V_{cc} reaches about 1.0V, $\overline{\text{RST}}$ is a guaranteed logic low of 0.4V or less. As V_{cc} rises, $\overline{\text{RST}}$ stays low. When V_{cc} rises above the reset threshold V_{RST} , an internal timer releases $\overline{\text{RST}}$ after about 1570ms (PT7M6314USxxD4). $\overline{\text{RST}}$ asserts whenever V_{cc} drops below the reset threshold, i.e. brownout condition. If brownout occurs in the middle of a previously initiated reset pulse, the pulse continues for at least another 200ms or 1570ms (PT7M6314USxxD4). On power-down, once V_{cc} falls below the reset threshold, $\overline{\text{RST}}$ stays low and is guaranteed to be 0.4V or less until V_{cc} drops below 1V.

Manual Reset

The manual-reset input ($\overline{\text{MR}}$) allows reset to be triggered by a pushbutton switch. The switch is effectively debounced by the 200ms (PT7M6314USxxD3) or 1570ms (PT7M6314USxxD4) reset pulse width.

Reset Output: Bi-direction

The PT7M6314USxx's RESET output is designed to interface with μP s that have bidirectional reset pins, such as the Motorola 68HC11. Like an open-drain output, the PT7M6314USxx allows the μP or other devices to pull $\overline{\text{RST}}$ low and assert a reset condition. However, unlike a standard open-drain output, it includes the commonly specified 5k Ω pull-up resistor with a P-channel active pull-up in parallel. This structure can speed the rising edge when the reset condition releases. The reset condition will occur when V_{cc} drops below the reset threshold, or Manual Reset is set to ground, or $\overline{\text{RST}}$ is pulled down.

Application Information

Typical Operation Circuit

Fig 6. PT7M6314USxx Application Example

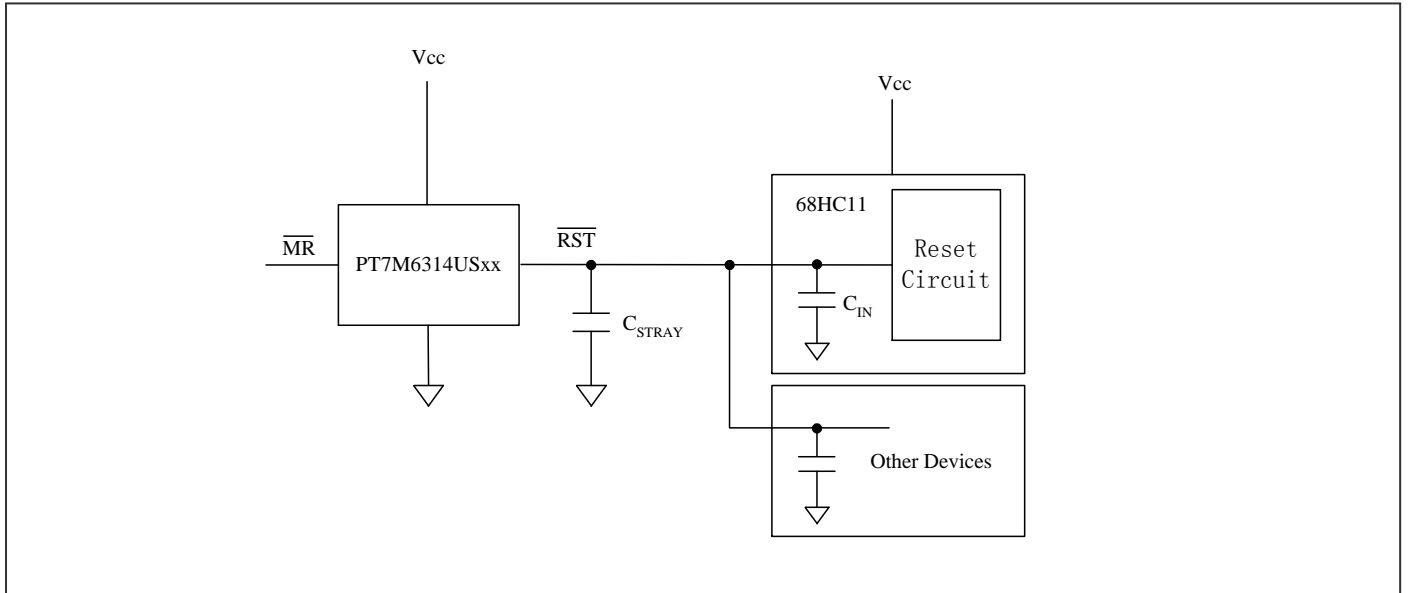

Mechanical Information

SOT143-4

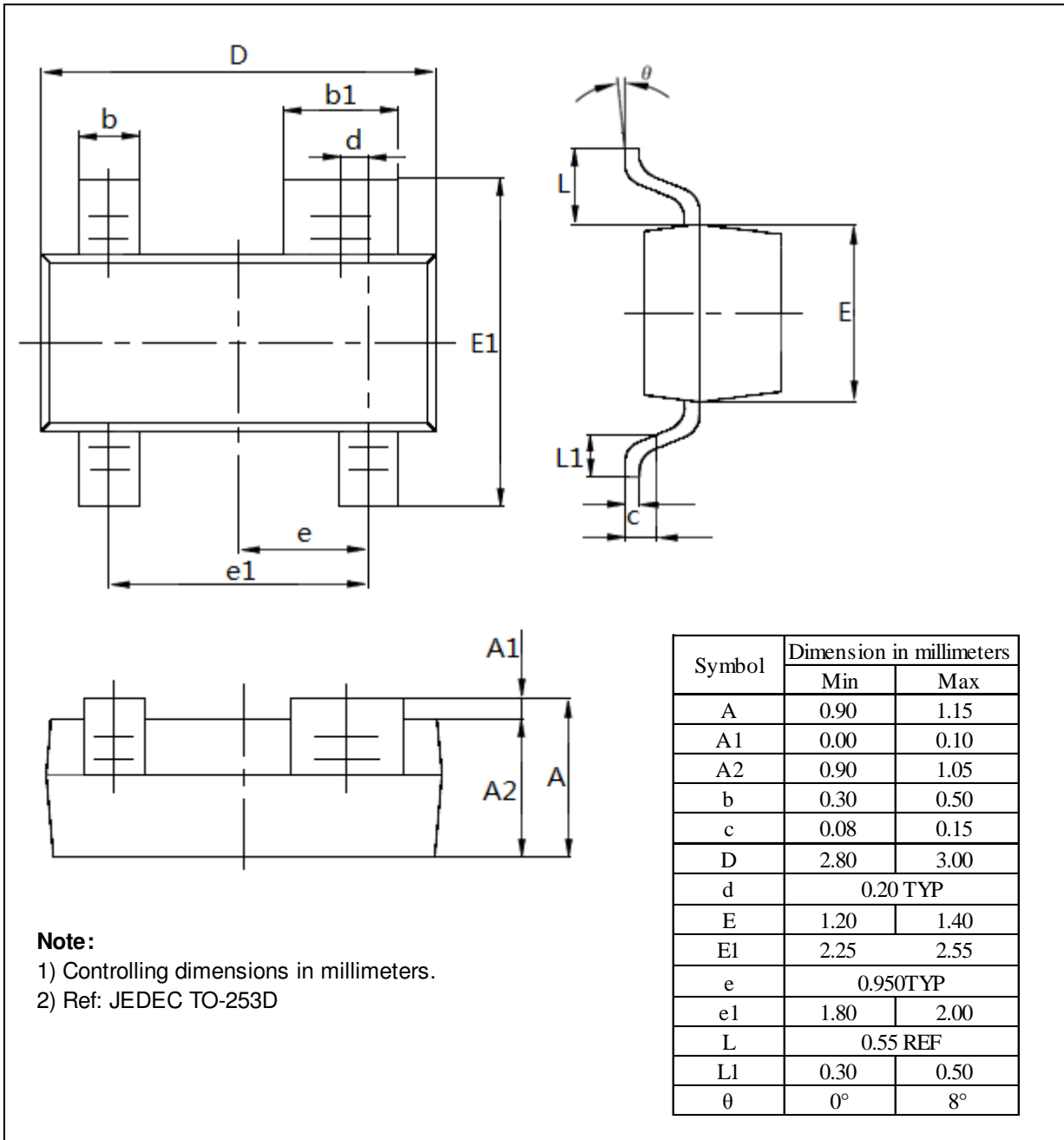

Ordering Information

Part Number	Package Code	Package
PT7M6314USxxD3FTBE	TB	Lead free and Green SOT143-4
PT7M6314USxxD4FTBE	TB	Lead free and Green SOT143-4

Note:

- “xx” refer to voltage range, see below table 1.
- E=Lead-free and Green Packaging
- Adding X suffix=Tape/Reel
- Contact Pericom for availability.

Table 1 Suffix “xx” definition of PT7M6314USxx

Suffix xx	V _{TH} (V)	Suffix xx	V _{TH} (V)	Suffix xx	V _{TH} (V)	Suffix xx	V _{TH} (V)
25	2.5	32	3.2	39	3.9	46	4.6
26	2.6	33	3.3	40	4.0	47	4.7
27	2.7	34	3.4	41	4.1	48	4.8
28	2.8	35	3.5	42	4.2	49	4.9
29	2.9	36	3.6	43	4.3	50	5.0
30	3.0	37	3.7	44	4.4		
31	3.1	38	3.8	45	4.5		

SOT-143 Package Top Marking Instruction

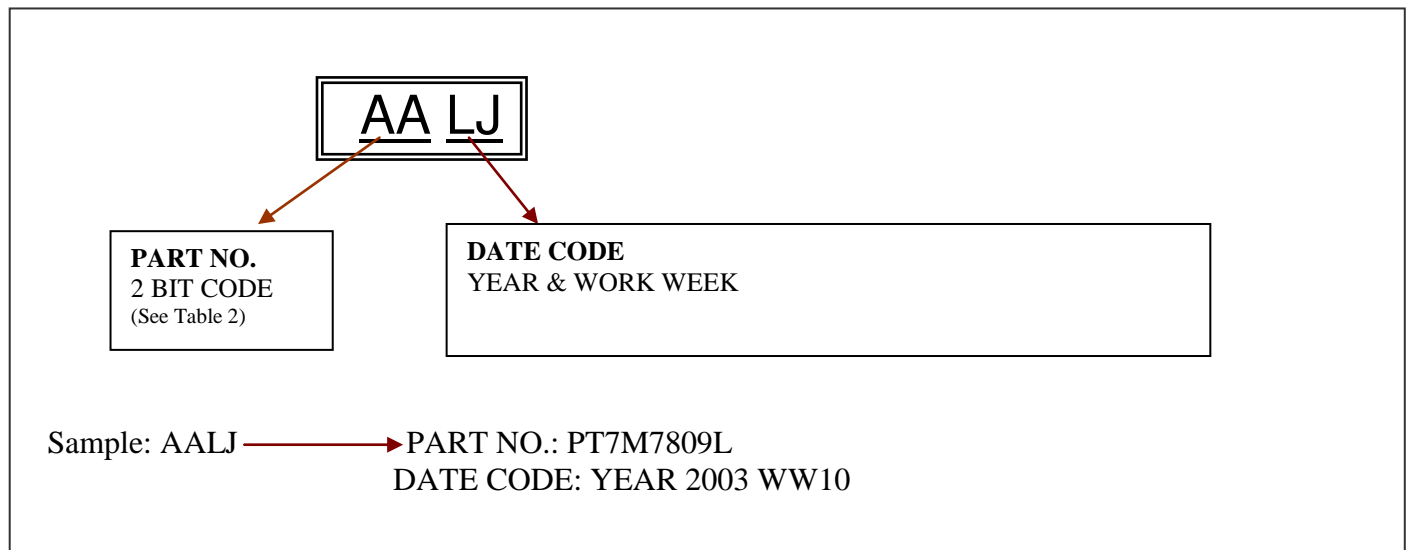

Table2

Part No.	Code	Part No.	Code	Part No.	Code
PT7M6314US25D3	SY	PT7M6314US34D3	UI	PT7M6314US43D3	VS
PT7M6314US25D4	SZ	PT7M6314US34D4	UJ	PT7M6314US43D4	VT
PT7M6314US26D3	TC	PT7M6314US35D3	UM	PT7M6314US44D3	VW
PT7M6314US26D4	TD	PT7M6314US35D4	UN	PT7M6314US44D4	VX
PT7M6314US27D3	TG	PT7M6314US36D3	UQ	PT7M6314US45D3	WA
PT7M6314US27D4	TH	PT7M6314US36D4	UR	PT7M6314US45D4	WB
PT7M6314US28D3	TK	PT7M6314US37D3	UU	PT7M6314US46D3	WE
PT7M6314US28D4	TL	PT7M6314US37D4	UV	PT7M6314US46D4	WF
PT7M6314US29D3	TO	PT7M6314US38D3	UY	PT7M6314US47D3	WI
PT7M6314US29D4	TP	PT7M6314US38D4	UZ	PT7M6314US47D4	WJ
PT7M6314US30D3	TS	PT7M6314US39D3	VC	PT7M6314US48D3	WM
PT7M6314US30D4	TT	PT7M6314US39D4	VD	PT7M6314US48D4	WN
PT7M6314US31D3	TW	PT7M6314US40D3	VG	PT7M6314US49D3	WQ
PT7M6314US31D4	TX	PT7M6314US40D4	VH	PT7M6314US49D4	WR
PT7M6314US32D3	UA	PT7M6314US41D3	VK	PT7M6314US50D3	WU
PT7M6314US32D4	UB	PT7M6314US41D4	VL	PT7M6314US50D4	WV
PT7M6314US33D3	UE	PT7M6314US42D3	VO		
PT7M6314US33D4	UF	PT7M6314US42D4	VP		

Pericom Semiconductor Corporation • 1-800-435-2336 • www.pericom.com

Pericom Technology Incorporation reserves the right to make changes to its products or specifications at any time, without notice, in order to improve design or performance and to supply the best possible product. Pericom Technology does not assume any responsibility for use of any circuitry described other than the circuitry embodied in Pericom Technology product. The company makes no representations that circuitry described herein is free from patent infringement or other rights, of Pericom Technology Incorporation.