

Dual LDO Regulator

Features

- Dual LDO Outputs (300mA/300mA)
- Dropout Voltage: 210mV@300mA
- Operating Voltage Range: 1.8V---5.5V
- Output Voltage Range: 1.2V---3.3V(100 mV Step)
- Highly Accurate: $\pm 2\%$
- Low Power Consumption: 55 μ A/LDOs (TYP)
- Standby Current: Less than 0.1 μ A (TYP)
- High Ripple Rejection: 75dB@1kHz
- Thermal Shutdown Protection
- Current Limit Protection
- Operating Temperature Range: -40 $^{\circ}$ C~+85 $^{\circ}$ C
- Low ESR Capacitor compatible: Ceramic capacitor
- Tiny TSOT-23-6L and SOT23-6L Package

Pin Configuration

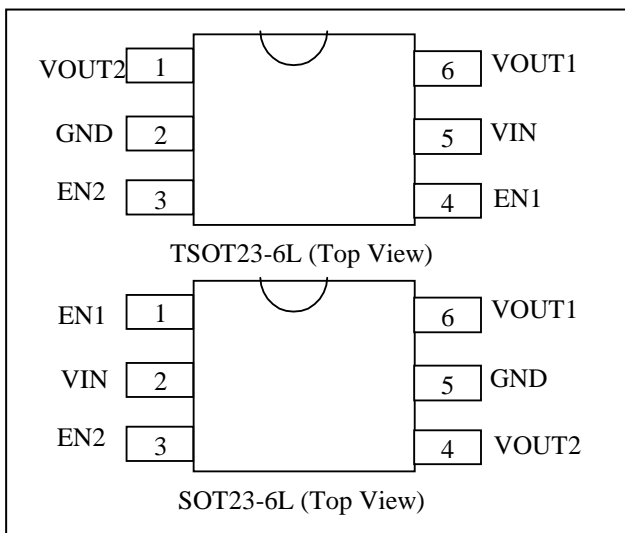

Description

The PT7M8411 series are highly accurate, dual, low noise, CMOS LDO voltage regulators. Performance features of the series include low output noise, high ripple rejection ratio, low dropout and very fast turn-on times. The PT7M8411 includes a reference voltage source, error amplifiers, driver transistors, current limiters and phase compensators internally. The output voltage for each regulator is set independently by trimming. Voltages are selectable in 100mV steps within a range of 1.2V to 3.3V includes 2.85V. The PT7M8411 series are also fully compatible with low ceramic capacitors, reducing cost and improving output stability. This high level of output stability is maintained even during frequent load fluctuations, due to the excellent transient response performance and high PSRR achieved across a broad range of frequencies. The EN function allows the output of each regulator to be turned off independently, resulting in greatly reduced power consumption.

Applications

- MP3/MP4/PMP
- Power supply for personal communication devices Mobile Phone
- Power supply for home appliance PHS RF and Baseband
- DSC CMOS Sensor
- GPS RF
- WLAN

Pin Description

PIN		I/O	Name	Descriptions
TSOT23-6L	SOT23-6L			
1	4	O	VOUT2	Output of Regulator 2. Bypass with a 1 μ F ceramic capacitor (X5R/X7R) to GND.
2	5	P	GND	Ground.
3	3	I	EN2	ON/OFF Control of Regulator 2.
4	1	I	EN1	ON/OFF Control of Regulator 1.
5	2	I	VIN	Regulators Supply Input. Supply voltage can range from 1.8V to 5.5V. Bypass with a 1 μ F ceramic capacitor (X5R/X7R) to GND.
6	6	O	VOUT1	Output of Regulator 1. Bypass with a 1 μ F ceramic capacitor (X5R/X7R) to GND.

Maximum Ratings

Storage Temperature.....	-55°C to +125°C
Ambient Temperature with Power Applied.....	-40°C to +85°C
Input Voltage (V _{IN}).....	+6.5V
Output Current (I _{OUT1} +I _{OUT2})	700mA
EN pin Voltage (V _{EN}).....	GND- 0.5 to +6.5V
DC Input/Output Current	700mA
Power Dissipation.....	SOT23/450mW TSOT23/450mW

Note:

Stresses greater than those listed under MAXIMUM RATINGS may cause permanent damage to the device. This is a stress rating only and functional operation of the device at these or any other conditions above those indicated in the operational sections of this specification is not implied. Exposure to absolute maximum rating conditions for extended periods may affect reliability.

Recommended Operating Conditions

Symbol	Parameter	Min.	Typ.	Max.	Unit
V _{CC}	Operating Voltage	1.8	-	5.5	V
T _A	Operating temperature	-40	25	85	°C

Electrical Characteristics (T_A=25°C, Bypass capacitor=22nF)

 Regulator 1, Regulator 2 T_A=25°C

Parameter	Symbol	CONDITIONS	Min.	Typ.	Max.	Unit	
Output Voltage	V _{OUT(E)} *2	V _{IN} =V _{OUT(S)} +1.0V I _{OUT} =30mA	*0.98	V _{OUT(S)} *1	*1.02	V	
Maximum output current	I _{OUTMAX}	V _{IN} =V _{OUT(T)} +1.0V	300	-	-	mA	
Load Regulation	ΔV _{OUT}	1.0 mA ≤ I _{OUT} ≤ 100 mA	-	8	20	mV	
Dropout Voltage	V _{DIF} *3	I _{OUT} = 300mA	1.7V ≤ V _{OUT(S)} ≤ 1.8V	-	0.40	0.80	V
			1.9V ≤ V _{OUT(S)} ≤ 2.3V	-	0.30	0.60	
			2.4V ≤ V _{OUT(S)} ≤ 2.7V	-	0.24	0.48	
			2.8V ≤ V _{OUT(S)} ≤ 3.3V	-	0.21	0.42	
Supply Current	I _{SS}	V _{IN} = V _{OUT} +1.0V No load	-	55	-	μA	
Standby Current	I _{STB}	V _{IN} =V _{OUT(S)} +1.0V V _{EN} =GND	-	-	1	μA	
Line Regulation	ΔV _{OUT} / ΔV _{IN} *V _{OUT}	V _{OUT(S)} +1V ≤ V _{IN} ≤ 5.5V, I _{OUT} = 30mA	-	0.05	0.20	%/V	
Input Voltage	V _{IN}	-	1.8	-	5.5	V	
Output Voltage Temperature characteristics	ΔV _{OUT} / ΔT _{opr} *V _{OUT}	I _{OUT} =30 mA -40°C ≤ T _A ≤ 85°C	-	±100	-	ppm/ °C	
Ripple Rejection Rate	PSRR	I _{OUT} =30 mA f=1kHz	-	75	-	dB	
Current Limiter	I _{LIM}	V _{IN} =V _{OUT(S)} +1.0V V _{EN} =V _{IN}	-	500	-	mA	
Thermal shutdown	T _{SD}	-	-	170	-	°C	
Thermal Shutdown Hysteresis	Δ T _{SD}	-	-	30	-		
EN"High"Voltage	V _{ENH}	-	1.3	-	6.5	V	
EN"Low"Voltage	V _{ENL}	-	-	-	0.3	V	
EN"High"Current	I _{IH}	V _{IN} =V _{EN} =V _{OUT} +1.0V	-0.10	-	0.10	μA	
EN"Low" Current	I _{IL}	V _{IN} =V _{EN} =V _{OUT} +1.0V, V _{EN} = V _{IN}	-0.10	-	0.10	μA	
Pull-down or Pull-up Resistance for EN Pin	R _{PULL}	-	-	5.0	-	MΩ	
ON-resistance of Nch for fast discharge	R _{DIS}	shut down	-	1	-	kΩ	

Note: *1: V_{OUT(S)}=Specified output voltage.

 *2: V_{OUT(E)}=Effective output voltage.

 (I.e. the output voltage when "V_{OUT(S)}+1.0V" is provided at the VIN pin while maintaining a certain I_{OUT} value).

 *3: V_{dif}={V_{IN1}(*5)-V_{OUT1}(*4)}.

 *4: V_{OUT1}=A voltage equal to 98% of the output voltage whenever an amply stabilized I_{OUT} {V_{OUT(S)} + 1.0V} is input.

 *5: V_{IN1}=The input voltage when V_{OUT1} appears as input voltage is gradually decreased.

 *6: Unless otherwise stated, V_{IN}=V_{OUT(S)}+1.0V

Typical Performance and Characteristics

1. Output Voltage vs. Output Current

PT7M8411 (1.8V)

Cin=1 μ F(Ceramics), Cout=1 μ F(Ceramics)

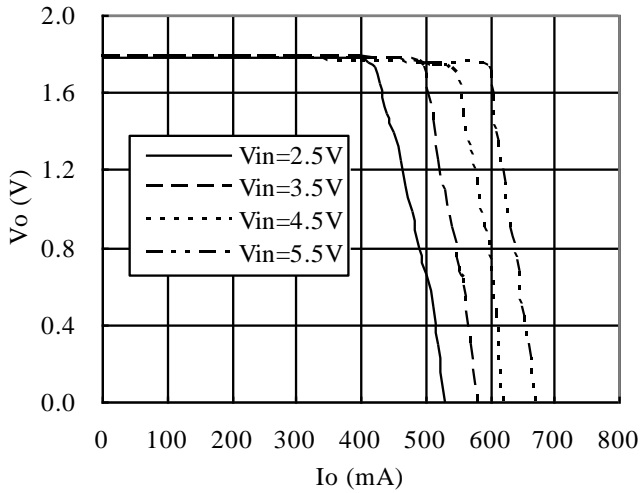

PT7M8411 (2.8V)

Cin=1 μ F(Ceramics), Cout=1 μ F(Ceramics)

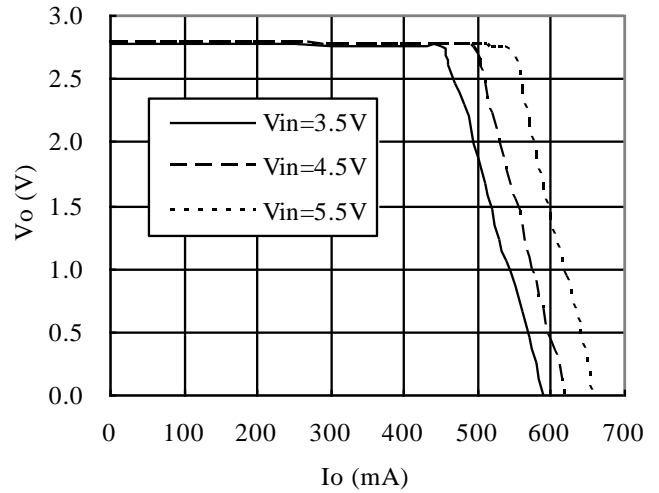

2. Output Voltage vs. Input Voltage

PT7M8411 (1.8V)

Topr=25°C

Cin=1 μ F(Ceramics), Cout=1 μ F(Ceramics)

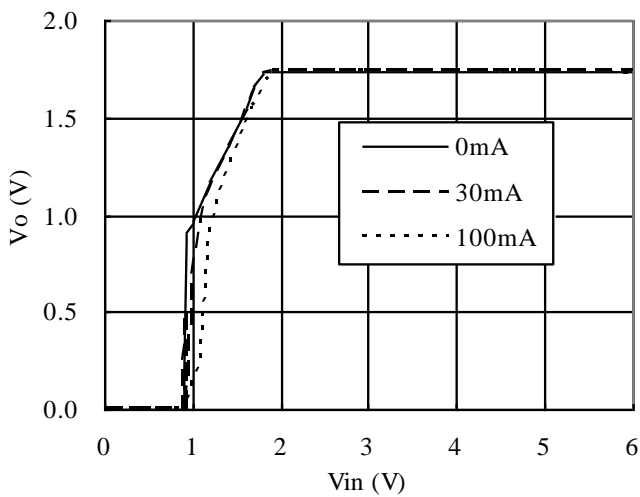

PT7M8411 (2.8V)

Topr=25°C

Cin=1 μ F(Ceramics), Cout=1 μ F(Ceramics)

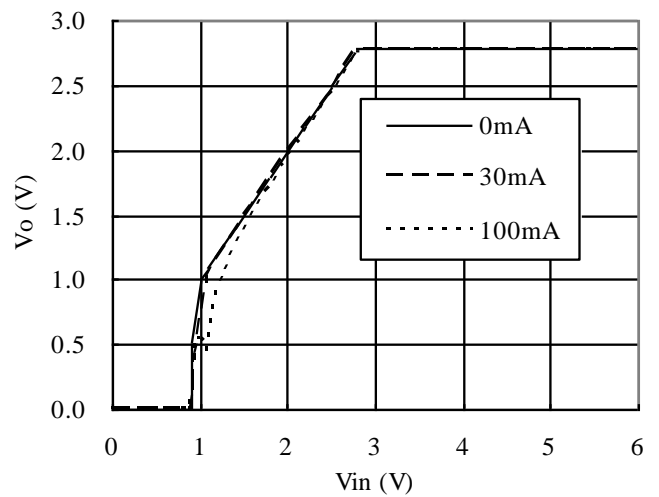

3. Dropout Voltage vs. Output Current

PT7M8411 (1.8V)

Cin=1 μ F(Ceramics), Cout=1 μ F(Ceramics)

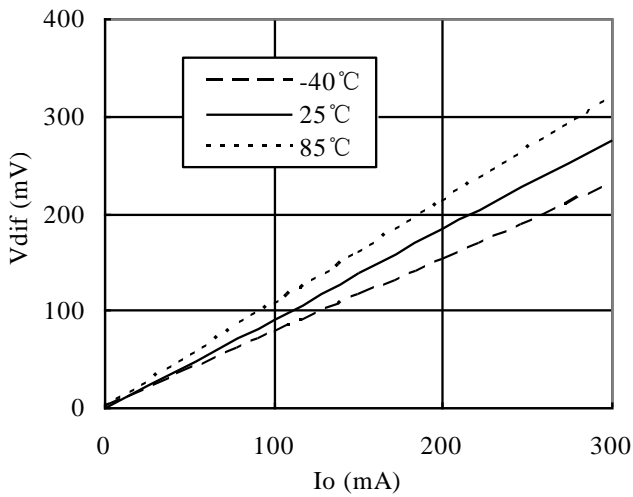

PT7M8411 (2.8V)

Cin=1 μ F(Ceramics), Cout=1 μ F(Ceramics)

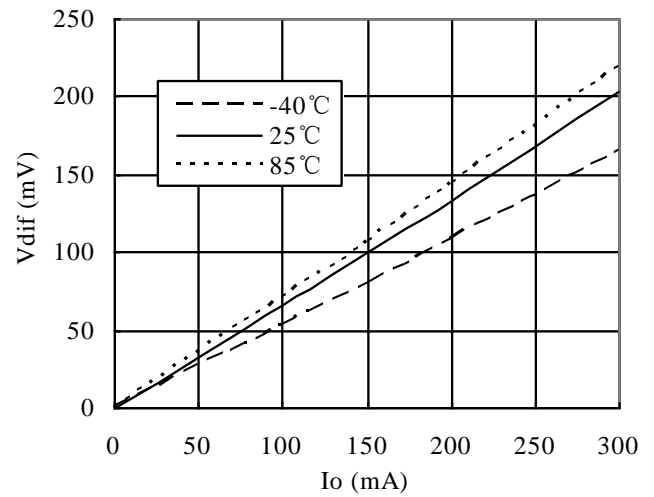

4. Supply Current vs. Input Voltage

PT7M8411 (1.8V)

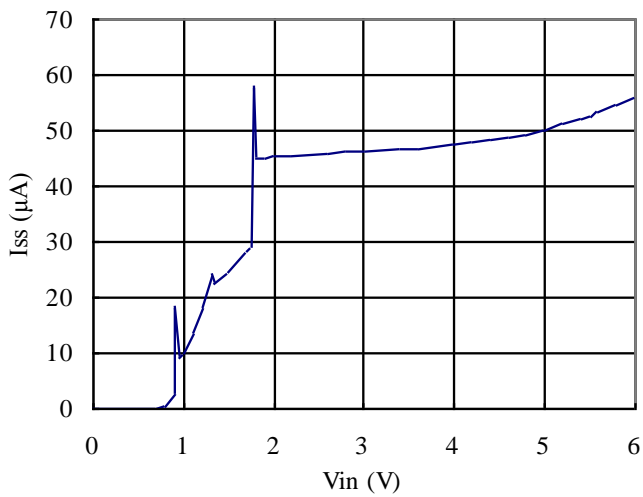

PT7M8411 (2.8V)

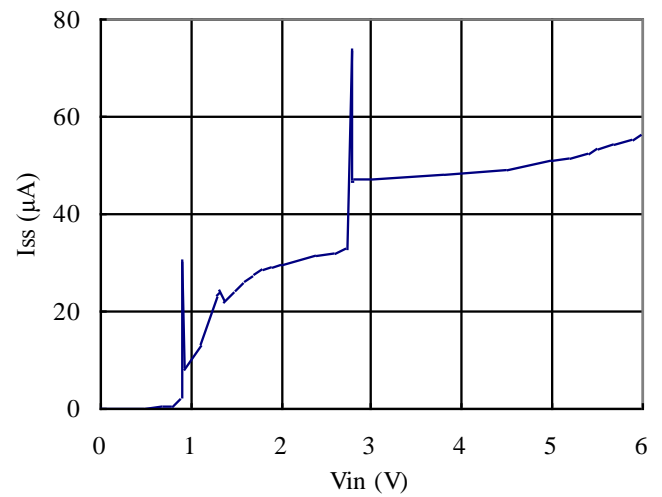

5. Output Voltage vs. Ambient Temperature

PT7M8411 (1.8V)

Vin=2.8V

Cin=1μF(Ceramics), Cout=1μF(Ceramics)

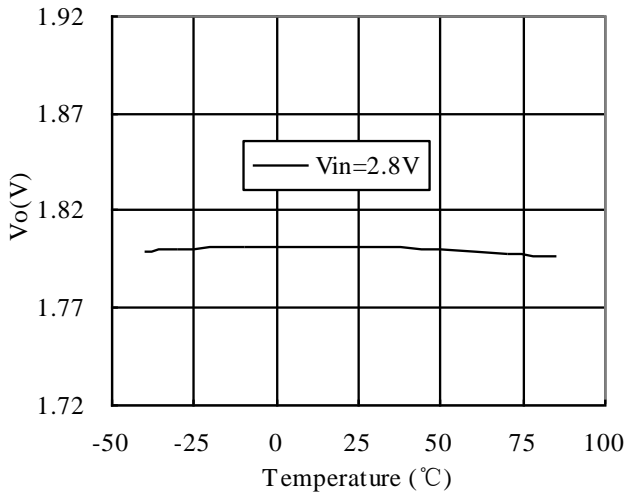

PT7M8411 (2.8V)

Vin=3.8V

Cin=1μF(Ceramics), Cout=1μF(Ceramics)

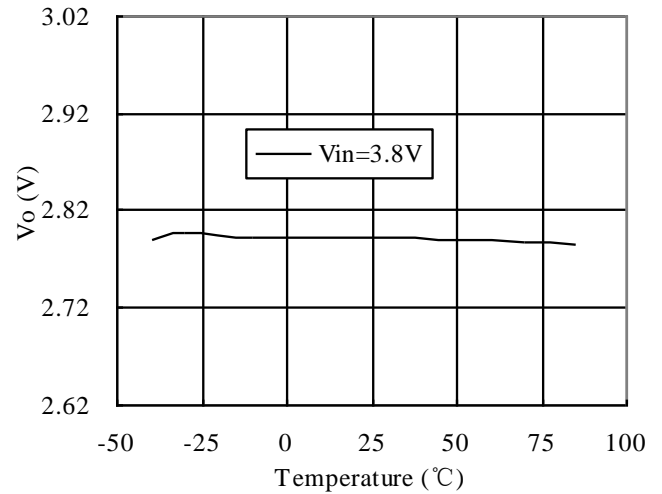

6. Supply Current vs. Ambient Temperature

PT7M8411 (1.8V)

Vin=2.8V

Cin=1μF(Ceramics), Cout=1μF(Ceramics)

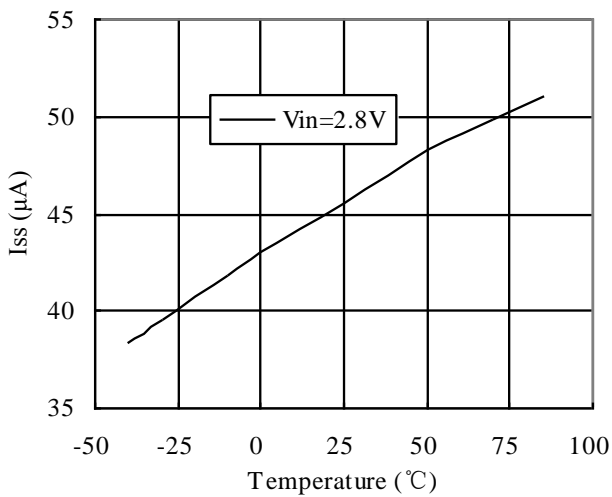

PT7M8411 (2.8V)

Vin=3.8V

Cin=1μF(Ceramics), Cout=1μF(Ceramics)

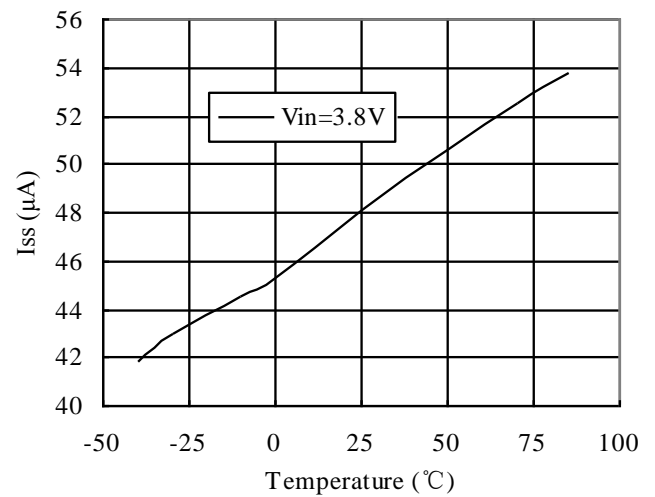

7. Input Transient Response

PT7M8411 (1.8V)

PT7M8411 (2.8V)

Cout=1 μ F(Ceramics), Iout=30mA, tr=tf=10 μ s

Cin= Cout=1 μ F(Ceramics), Iout=30mA, tr=tf=10 μ s

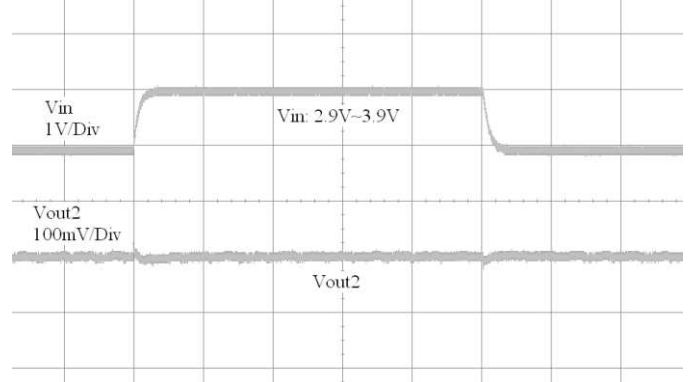
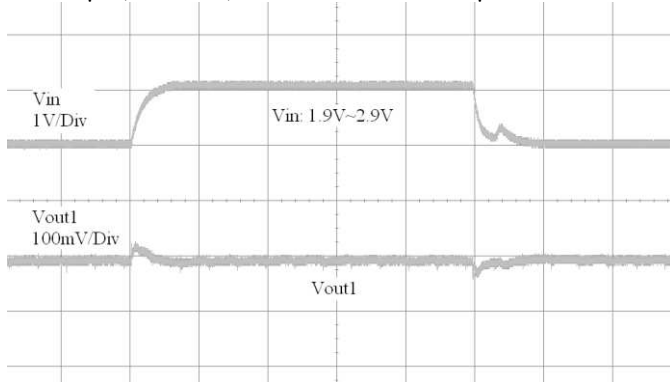

8. Load Transient Response and Cross Talk

PT7M8411 (1.8V)

PT7M8411 (2.8V)

Cin=Cout=1 μ F(Ceramics), Vin=3.3V, tr=tf=1 μ s

Cin=Cout=1 μ F(Ceramics), Vin=3.3V, tr=tf=1 μ s

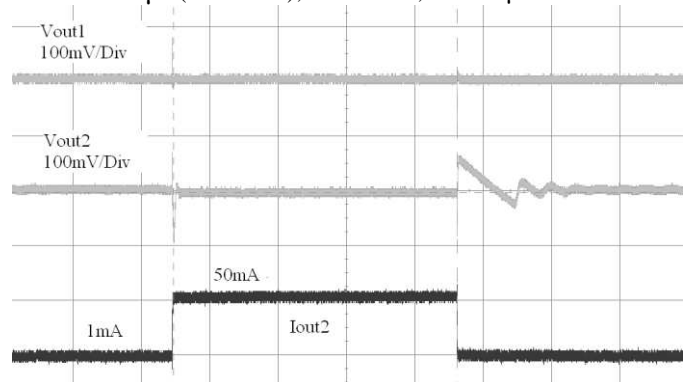
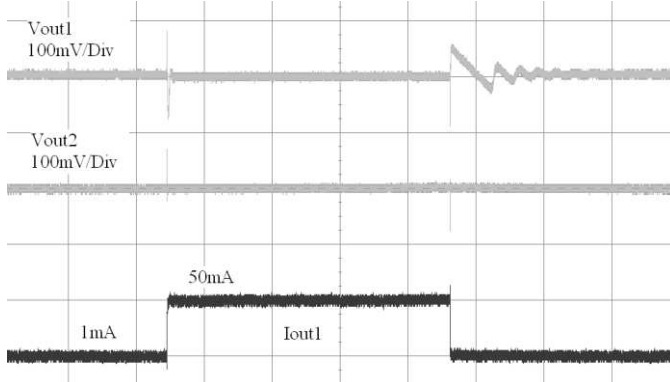

PT7M8411 (1.8V)

PT7M8411 (2.8V)

Cin=Cout=1 μ F(Ceramics), Vin=3.3V, tr=tf=1 μ s

Cin=Cout=1 μ F(Ceramics), Vin=3.3V, tr=tf=1 μ s

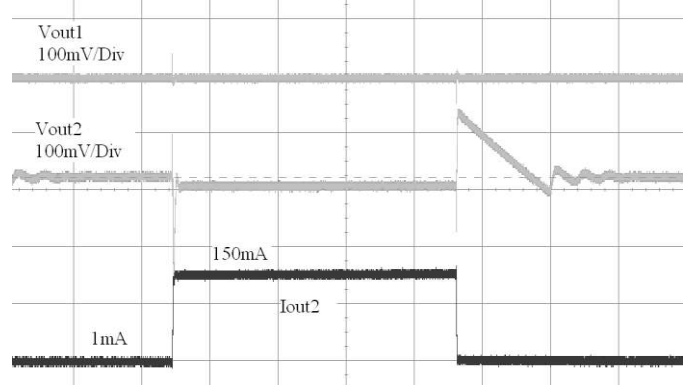
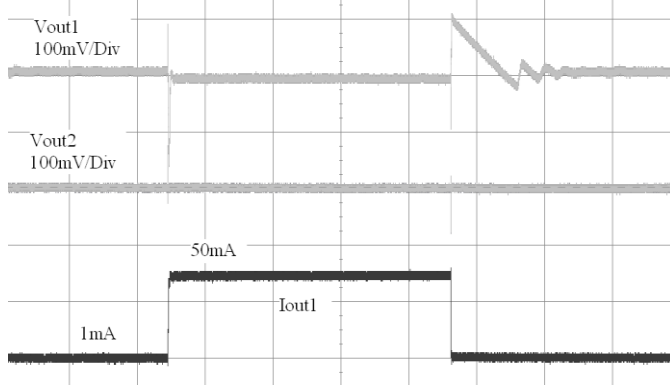

PSRR

PT7M8411 (1.8V)

$V_{in}=2.8V\ DC+1V_{p-p}AC$
 $C_{out}=1\mu F(Ceramics), I_{out}=30mA$

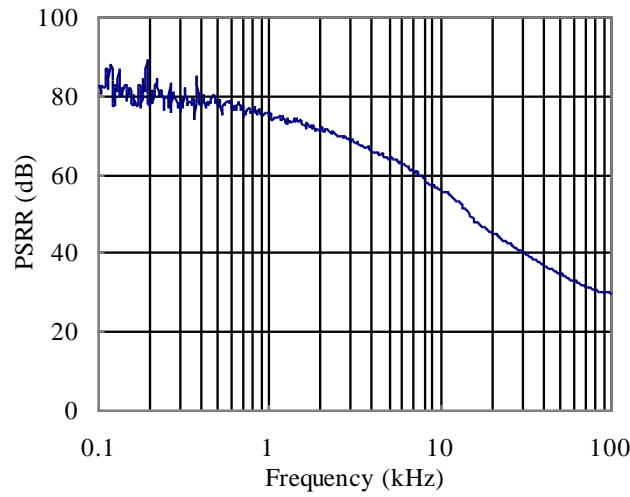

Function block diagram

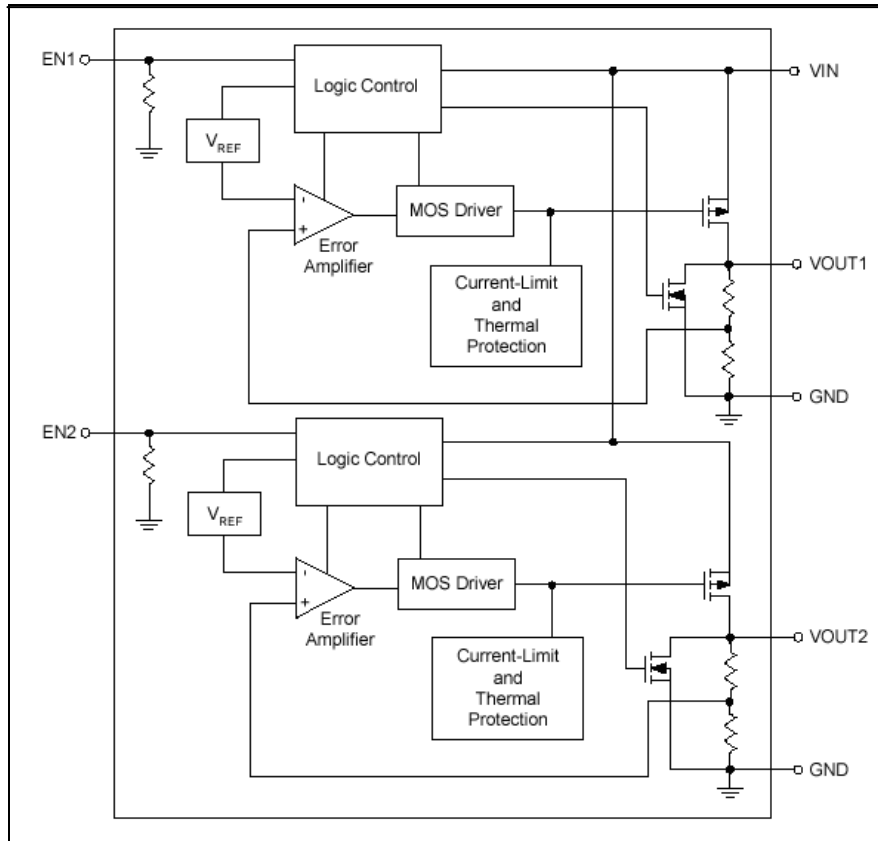

Functional Description (Refer to Function Block Diagram)

Output voltage control

The P-Channel MOSFETs which are connected to the VOUT1 and VOUT2 pins, are then driven by the subsequent output signal. The output voltages at the VOUT1 and VOUT2 pins are controlled and stabilized by a system of negative feedback. The current limit circuit operates in relation to the level of output current. Further, the IC's internal circuitry can be shutdown via the EN1 and EN2 pin's signal.

Low ESR Capacitors

With the PT7M8411 series, a stable output voltage is achievable even if used with low ESR capacitors as a phase compensation circuit is built-in. In order to ensure the effectiveness of the phase compensation, we suggest that output capacitors are connected as close as possible to the output pins (VOUT1 and VOUT2) and the GND pin. Please use an output capacitor with a capacitance value of 1 μ F. Also, please connect an input capacitor of 1 μ F between the VIN pin and the GND pin in order to ensure a stable power input.

Current Limiter

The PT7M8411 series includes a fixed current limiter circuit & a foldback circuit. When the load current reaches the current limit level, the fixed current limiter circuit operates and output voltage drops.

Thermal Overload Protection

Thermal overload protection limits total power dissipation in the PT7M8411. When the junction temperature exceeds $T_J = +170^{\circ}\text{C}$, a thermal sensor turns off the pass transistor, allowing the device to cool. The thermal sensor turns the pass transistor on again after the junction temperature cools by -40°C , resulting in a pulsed output during continuous thermal overload conditions. Thermal overload protection protects the PT7M8411 in the event of fault conditions. For continuous operation, do not exceed the absolute maximum junction-temperature rating of $T_J = +125^{\circ}$

EN Pins

The IC's internal circuitry can be shutdown via the signal from the EN1 and EN2 pins with the PT7M8411 series. In shutdown mode, output at the VOUT1 and VOUT2 pins will be pulled down to the GND level. For protecting the system, the PT7M8411 have a quick-discharge function. The operational logic of the IC's EN1 and EN2 pins are selectable.

NOTE ON USE

Please use this IC within the stated absolute maximum ratings. The IC is liable to malfunction should the ratings be exceeded. Where wiring impedance is high, operations may become unstable due to noise and/or phase lag depending on output current. Please keep the resistance low between IN and GND wiring in particular. Please wire the input capacitor and the output capacitors as close to the IC as possible.

Application Circuit

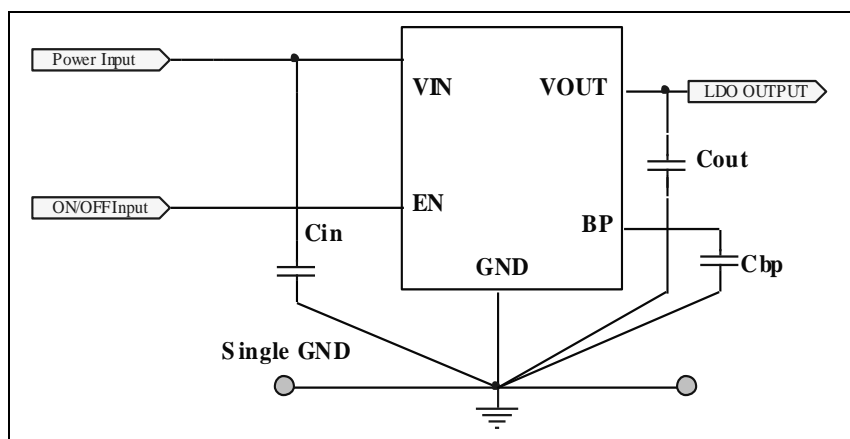

Note: $C_{in} = C_{out} = 1\mu\text{F}$, $C_{bp} = 22\text{nF}$

Mechanical Information

TTE (Lead free and Green TSOT23-6L)

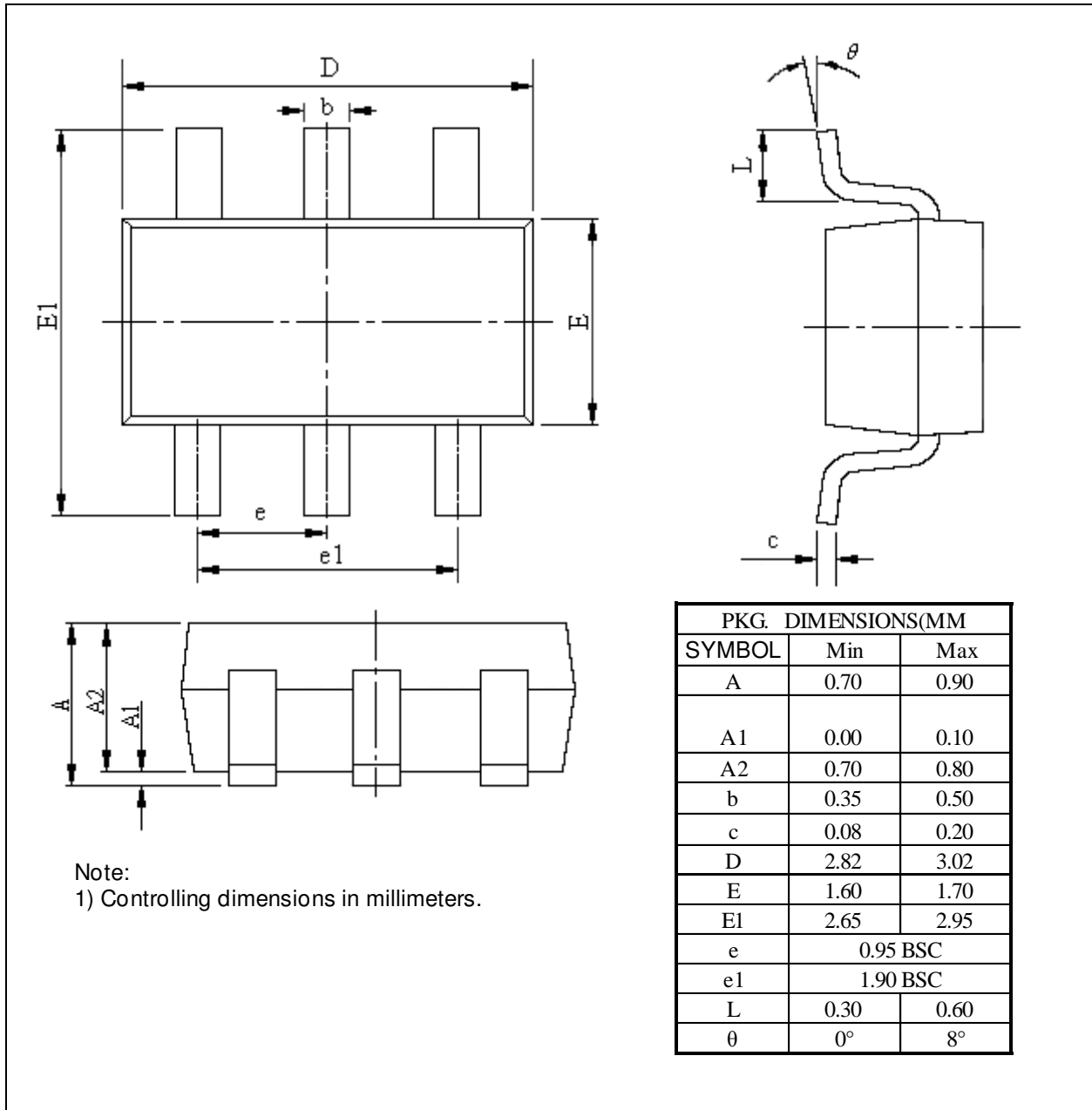

TAE (Lead free and Green SOT23-6L)

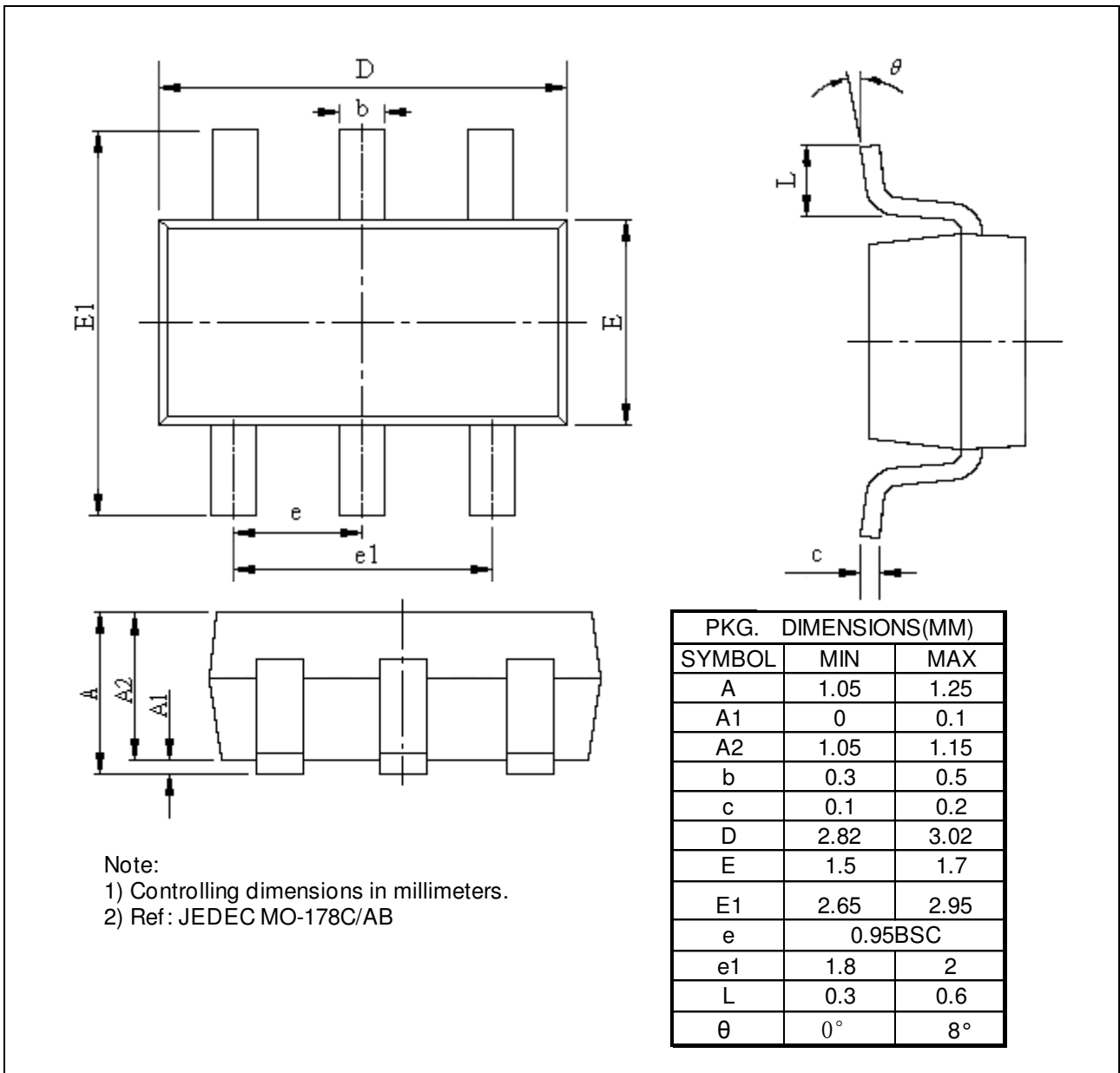

Ordering Information

Part Number	Package Code	Package
PT7M8411①②③④TA6E	TA	Lead free and Green SOT23-6L
PT7M8411①②③④TT6E	TT	Lead free and Green TSOT23-6L

Notes:

- “①②③④” refer to different functions. See below Table 1 and Table 2.
- E = Pb-free and Green
- Adding X Suffix= Tape/Reel

Table 1 Option Definition Table

Designator	Symbol	Description
①②	12-33, 2A	Internally set sequential number relating output voltage of regulator1 Regulator 1 Output Voltage Range: 1.2V~ 3.3V, 2.85V the detail is in table2
③④	12-33, 2A	Internally set sequential number relating output voltage of regulator2 Regulator 2 Output Voltage Range: 1.2V~ 3.3V, 2.85V the detail is in table2

Table 2 Definition of designator

Designator ①② or ③④	VOUT (V)	Designator ①② or ③④	VOUT (V)	Designator ①② or ③④	VOUT (V)
12	1.2	20	2.0	28	2.8
13	1.3	21	2.1	29	2.9
14	1.4	22	2.2	30	3.0
15	1.5	23	2.3	31	3.1
16	1.6	24	2.4	32	3.2
17	1.7	25	2.5	33	3.3
18	1.8	26	2.6	2A	2.85
19	1.9	27	2.7		

Pericom Semiconductor Corporation • 1-800-435-2336 • www.pericom.com

Pericom reserves the right to make changes to its products or specifications at any time, without notice, in order to improve design or performance and to supply the best possible product. Pericom does not assume any responsibility for use of any circuitry described other than the circuitry embodied in Pericom product. The company makes no representations that circuitry described herein is free from patent infringement or other rights, of Pericom.