

Ceramic Heat Controller

Features

- High watt density Alumina Heaters
- High current pulse trigger for SCR
- Quickly Heating-Up and Quickly Lost-Heat-Recover
- Dual voltage 120VAC / 240VAC
- Internal 5v zener
- Insensitive to environment temperature
- Auto power off (Optional)
- DIP-8 and SOIC-8 package

Description

The PT8A330X is specially designed for ceramic heating control system. It can set the temperature continuously .It can drive SCR directly and detect the heater temperature without extra temperature sensor. It will start heat after power on and has one LED for working state indication. Build-in timer will automatically power off after turn on for 1 hour @ 60Hz or 1.2 hour @ 50Hz (for PT8A3300/1).

Applications

- Ceramic heating controller

Pin Configuration

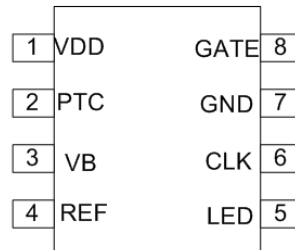

Pin Description

Name	Pin No.	Type	Description
VDD	1	power	Power input or can be used as OFF push button input
PTC	2	I	Temperature sensor input
VB	3	O	Sampling bias voltage
REF	4	O	Reference for internal comparator
LED	5	O	LED driver output
CLK	6	I	Clock input from AC power line
GND	7	power	Power Ground
GATE	8	O	SCR trigger output, active high

Block Diagram

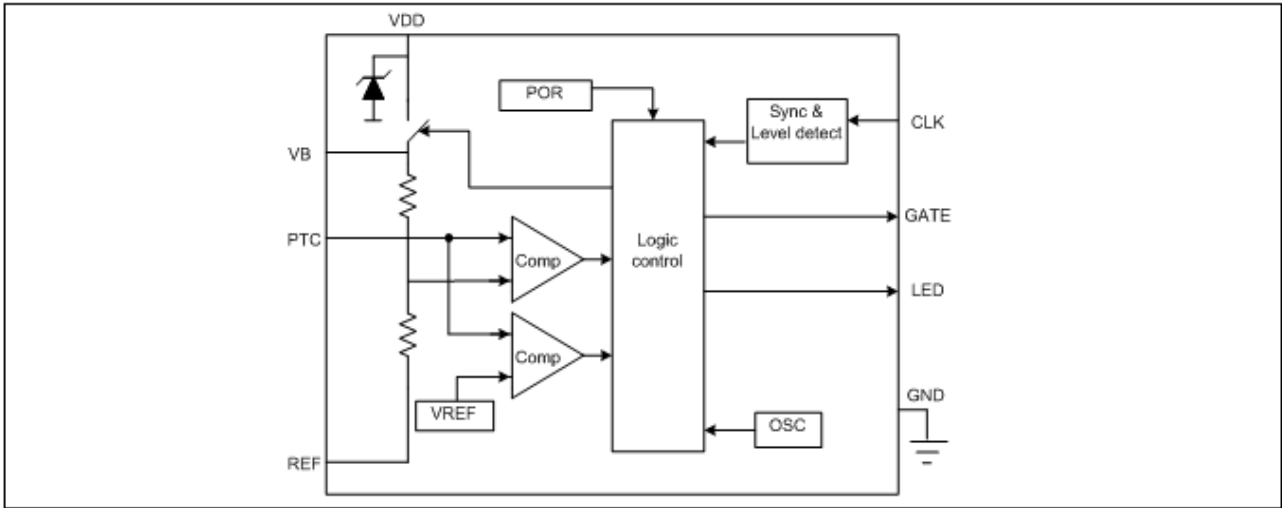

Maximum Ratings

Storage Temperature	-55°C to +150°C
Supply Voltage to Ground Potential (Input & V _{DD} Only).....	-0.5V to +6.5V
Supply Voltage to Ground Potential (Output s Only)	-0.5V to +6.5V
DC Input Voltage	-0.5V to +6.5V
Input/Output Current	50mA
Input/Output Current(Pin VDD, VBonly).....	200mA
Power Dissipation	500mW

Note:

Stresses greater than those listed under MAXIMUM RATINGS may cause permanent damage to the device. This is a stress rating only and functional operation of the device at these or any other conditions above those indicated in the operational sections of this specification is not implied. Exposure to absolute maximum rating conditions for extended periods may affect reliability.

Recommended operation conditions

Symbol	Description	Min	Type	Max	Unit
T _A	Operation Temperature	-20	-	+85	°C
V _{DD}	Supply voltage	4.0	4.5	5.0	V

Electrical Characteristics ($V_{DD} = 4.5$, $T_A = -20 \sim 85^\circ\text{C}$, unless otherwise noted)

DC Electrical Characteristics

Symbol	Description	Test Conditions		Min	Type	Max	Unit
I_{IH}	Input high current	PIN: PTC ,CLK	$V_{IN} = V_{DD}$	-	-	5	μA
I_{IL}	Input low current	PIN: PTC ,CLK, REF	$V_{IN} = \text{GND}$	-	-	-5	μA
R_{REF}	The resistor between REF and GND	PIN: REF	$V_{IN} = 1\text{V}$	20	47	80	K Ohms
I_{OH}	Output High Current	PIN: GATE	$V_{DD} = 4.5\text{V}$ $V_{OUT} = 2.5\text{V}$	-15	-	-	mA
I_{OL}	Output Low Current	PIN: GATE	$V_{DD} = 4.5\text{V}$ $V_{OUT} = 0.5\text{V}$	4.0	-	-	mA
$I_{VB_{SHORT}}$	Output short current	PIN: VB, VB short to GND		IC No break	-	-	mA
R_{ON_VB}	Resistor of switch on	PIN: VDD to VB	$V_{DD} = 4.5\text{V}$ $I_{OUT} = 100\text{mA}$	-	-	15	Ohms
R_{OFF_VB}	Resistor of switch off	PIN: VDD to VB	$V_{DD} = 4.5\text{V}$ $I_{OUT} < 1\mu\text{A}$	5M	-	—	Ohms
R_{ON_TS}	Resistor of Rma_TSet	PIN: VB to REF	$V_{DD} = 4.5\text{V}$ $I_{OUT} = 50\mu\text{A}$	35	-	65	K ohms
I_{OH}	Output High Current	PIN: LED	$V_{DD} = 4.5\text{V}$ $V_{OUT} = 3.5\text{V}$	-3	-	-	mA
I_{OL}	Output Low Current	PIN: LED	$V_{DD} = 4.5\text{V}$ $V_{OUT} = 1.5\text{V}$	5	-	-	mA

Power Supply Characteristics

Symbol	Description	Test Conditions	Min	Type	Max	Unit
V_{POR}	Voltage of POR	-	2.0	-	3.0	V
I_{DD}	Current consumption	No loading, $V_{DD} = 4.5\text{V}$ (Internal zener doesn't work)	-	200	400	μA
V_{DD}	Supply voltage	$I_{DD} = 0.3 \sim 10\text{mA}$ (according to the zener inside) Control function normal	4.0	-	5.5	V
TPO_{off}	Power off timer	$F_{CLK} = 50\text{Hz}$	1.15	1.2	1.25	Hour

Line Clock Synchronization Characteristics

Symbol	Description	Test Conditions	Min	Type	Max	Unit
F_{CLK}	Frequency of CLK	-	-	50/60	-	Hz
V_{LEVEL}	Input voltage of CLK Pin	-	1.69	1.88	2.07	V
V_{TCLK}	Compare Threshold Voltage of CLK Pin	Low level, AC=220V/50Hz $V_{DD} = 4.5V$,	-200	-250	-300	mV
		High level, AC=220V/50Hz $V_{DD} = 4.5V$,	-100	-150	-200	mV
		Low level, AC=110V/60Hz $V_{DD} = 4.5V$	-240	-190	-140	mV
		High level, AC=110V/60Hz $V_{DD} = 4.5V$	-140	-90	-60	mV

VB and GATE Pulse Characteristics

Symbol	Description	Test Conditions	Min	Type	Max	Unit
T_{al_VB}	Width of VB pulse	$T_A=25^\circ C$, $V_{DD} = 4.5V$	80	100	120	μs
		$V_{DD} = 4.5V$ $T_A = -20 \sim 85^\circ C$	60	-	150	μs
T_{al_GATE}	Width of Gate trigger pulse	$T_A=25^\circ C$, $V_{DD} = 4.5V$	160	200	240	μs
		$V_{DD} = 4.5V$ $T_A = -20 \sim 85^\circ C$	120	-	300	μs

EMC Electrical Characteristics

Symbol	Description	Test Conditions	Min	Type	Max	Unit
EFT	IEC61000-4-4 Transient/Bursts	EN/IEC61000-4-4 is Electrical fast transient / burst immunity test, requirement > 1000V pulse amplitude ($T_r=5ns$, $T_w=50ns$, $Z=50$ ohms, burst duration 15 ms, burst period 300 ms, burst frequency 2,5 kHz)	2000	-	-	V_{PP}

Temperature Control Characteristics

Symbol	Description	Test Conditions		Min	Type	Max	Unit
V_T	Normal heat-up Threshold Voltage	$V_{DD} = 4.5V$ $V_{REF}=0.7V$ Test GATE output about 50% heating power		-	$0.5(V_B - V_{REF})$	-	V
V_{TH}	Fast heat-up Threshold Voltage	PT8A330xB (x: 0~3)	$V_{DD}=4.5V$ $V_{REF}=0.7V$ Test GATE output about 50% heating power	$V_T + 0.4\%(V_B - V_{REF})$	$V_T + 0.6\%(V_B - V_{REF})$	$V_T + 0.8\%(V_B - V_{REF})$	V
		PT8A330xA (x: 0~3)		$V_T + 1.9\%(V_B - V_{REF})$	$V_T + 2.1\%(V_B - V_{REF})$	$V_T + 2.3\%(V_B - V_{REF})$	
V_{OS_COMP}	Input Offset Voltage of Comparator	Pin: PTC		-3mV	-	+3mV	mV
T-heat	Heating cycle time	$F_{CLK} = 50Hz$		-	200	-	ms

Function description

- Input Button**
No key: (Only for PT8A3300/1/2/3)
 Auto start heating-on when power on.
- One LED Indicator**
Flash: (Only for PT8A3300/2)
 When turn -on, the LED will flash (1.5Hz @50Hz power CLK) to indicate the heater is being heated, and keep lighting while reaching the desired temperature.
Constant (Only for PT8A3301/3)
 The LED will keep lighting after turn-on.
- Reset**
 After power on the chip will be reset by POR circuit, LED is disabled. GATE is low level.
- Timer**
 Once the IC power on, the internal timer will start to count. After 216000 clock period, the IC will power off the heater until power on reset again. For the 60Hz CLK signal, the maximal heating time is about 1 hour; and 1.2 hour for 50Hz (for PT8A3300/1).

High Current pulse triggering for SCR

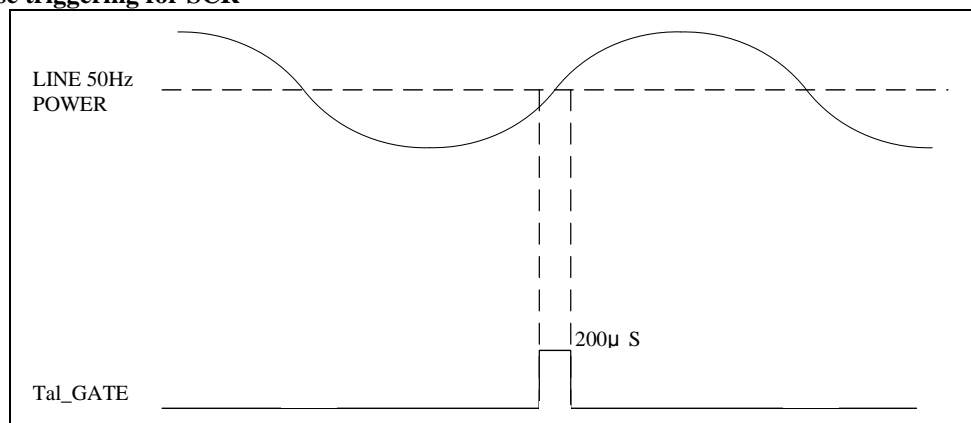

- High trigger peak current (>15mA), enough to trigger 20A SCR
- Pulse triggering current to reduce the false self trigger by the leakage of SCR at high temperature environment.
- Ta1_GATE = 200us

Timing

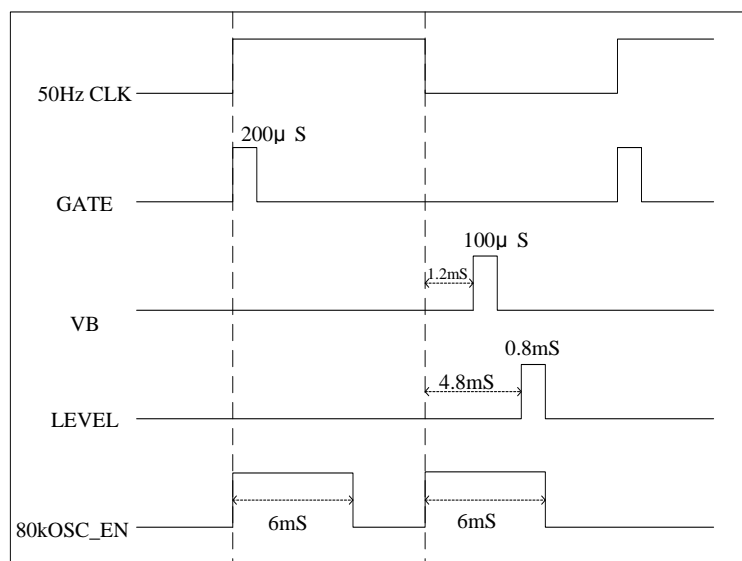

Application Circuit

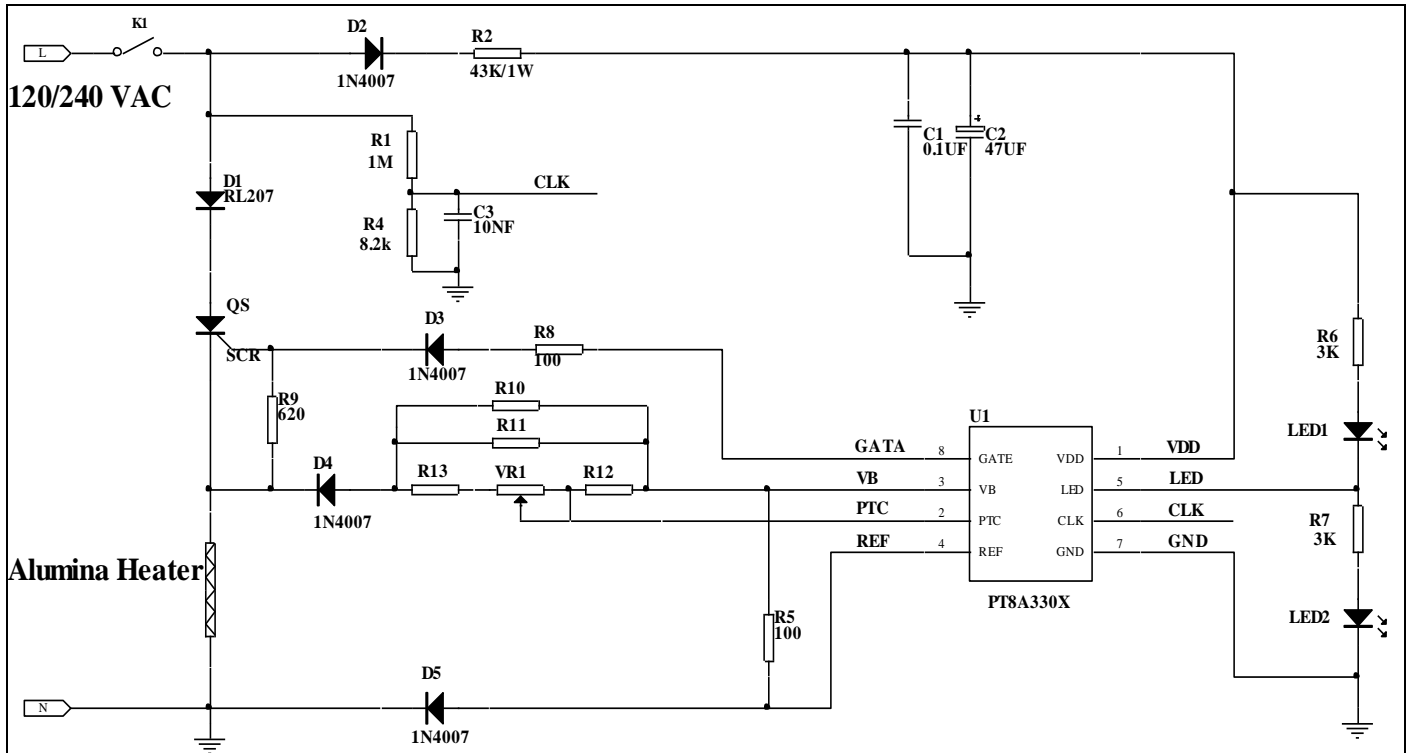

Mechanical Information

PE (DIP-8)

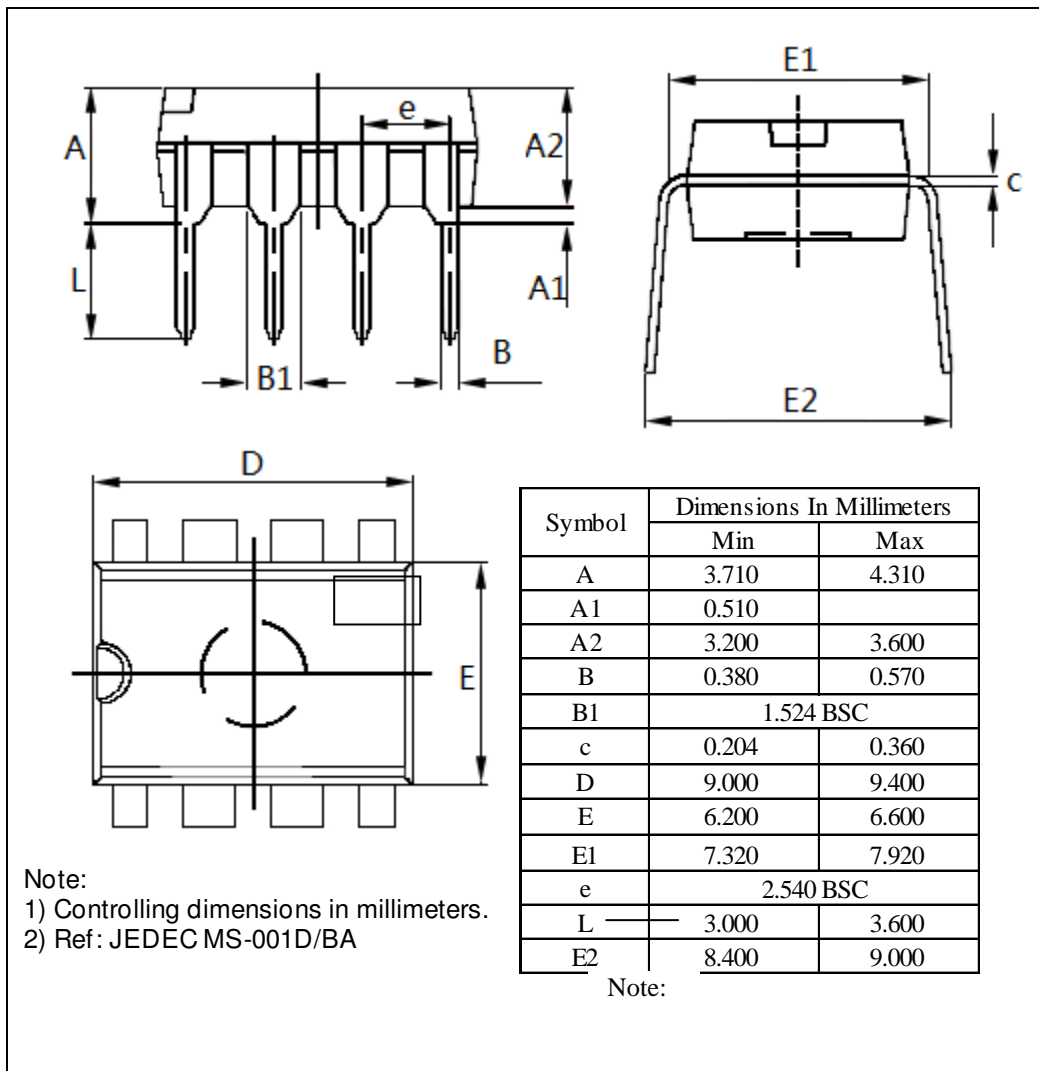

WE (SOIC-8)

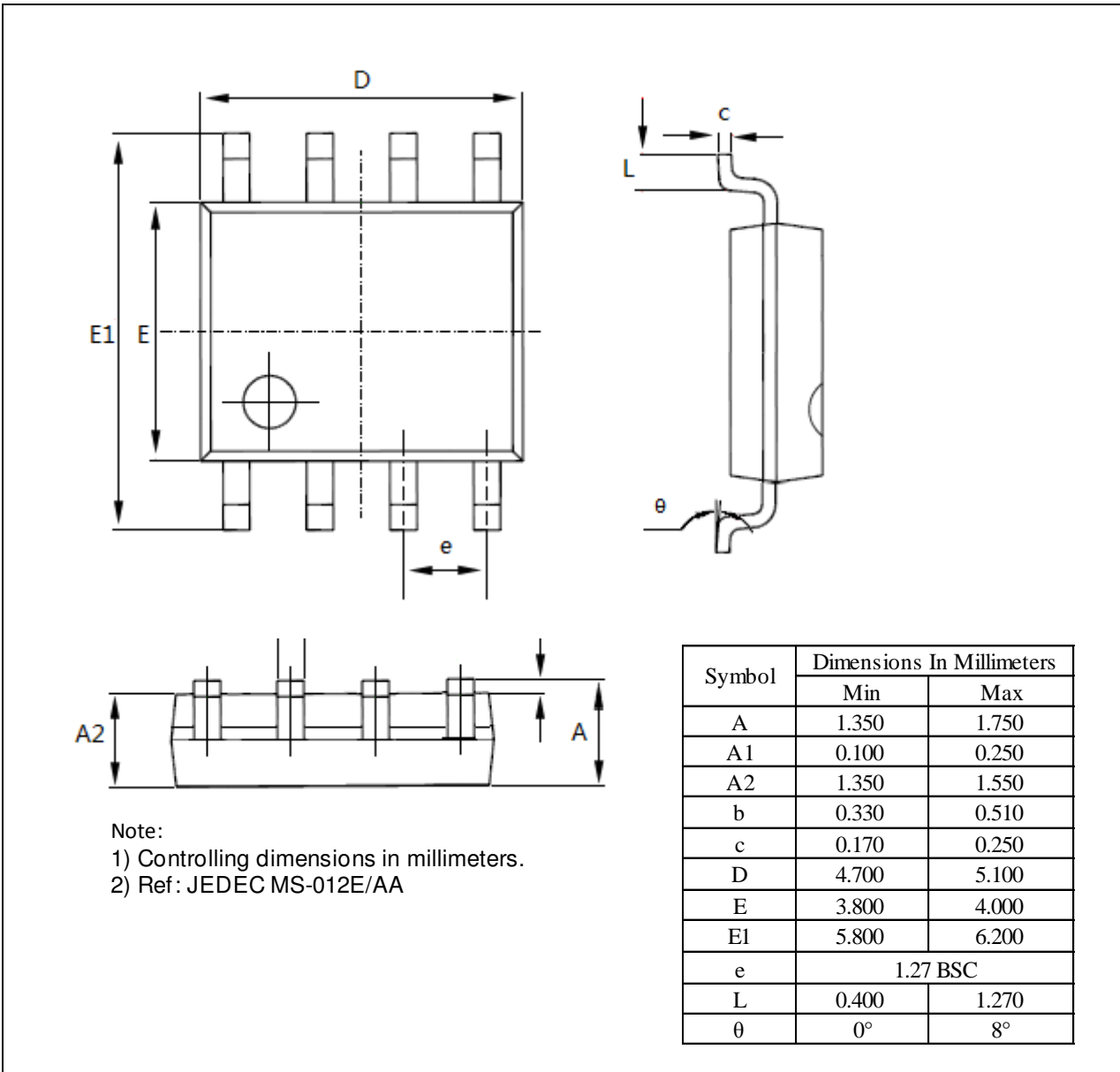

Ordering Information

Part No.	Package Code	Package
PT8A330xAPE	P	Lead free 8-pin DIP
PT8A330xAWE	W	Lead free and Green 8-pin SOIC
PT8A330xBPE	P	Lead free 8-pin DIP
PT8A330xBWE	W	Lead free and Green 8-pin SOIC

Note:

- “x” shows 0~3 with different function see Function Comparison Table.
- E = Pb-free or Pb-free & Green
- Adding X Suffix= Tape/Reel

Function Comparison Table

Part No.	IED	Timer	Switch On/OFF	**VTH – VT
PT8A3300A*	Flash	Y	No Key	High overshoot when preheat
PT8A3300B*	Flash	Y	No Key	Low overshoot when preheat
PT8A3301A	Constant	Y	No Key	High overshoot when preheat
PT8A3301B	Constant	Y	No Key	Low overshoot when preheat
PT8A3302A	Flash	N	No Key	High overshoot when preheat
PT8A3302B	Flash	N	No Key	Low overshoot when preheat
PT8A3303A	Constant	N	No Key	High overshoot when preheat
PT8A3303B*	Constant	N	No Key	Low overshoot when preheat

Note:

- * Contact Pericom for availability.
- ** Refer to page 4