

5LED Ceramic Heating Controller

Features

- Pulse trigger with high current for SCR
- Quickly Heating-Up and Quickly Lost-Heat-Recover
- External Adjustable to fit wide range heating plates
- External Adjustable to different TCR of sensors
- Full temperature compensation and insensitive to environment temperature
- 5 Heat Temperature Settings
- Auto power off (only for PT8A3252)
- Over Temperature protection
- DIP-16 and SOIC-16 packages

Applications

- Ceramic Heating Controller
- High watt density Alumina Heaters

Description

The PT8A3252/54 is specially designed for ceramic heating control with 5 internal level of 130°C, 145°C, 160°C, 175°C, 190°C. And the temperature range can be adjusted from 100°C to 250°C by external series resistance. It can drive SCR directly and detect heater temperature by heater-self without extra temperature sensor. It has 3 keys for function setting, 5 LEDs for working status indication. The PT8A3252 has an internal timer; it timeouts and device will stop heating automatically after 216000 clock period, ie. 1 hour for 60Hz and 1.2 hour for 50Hz. The circuit of Over-Heat Protection will be working for safety when heater temperature reached to 250°C. The chip is packaged in lead free DIP-16 and SOIC-16.

Pin Configuration

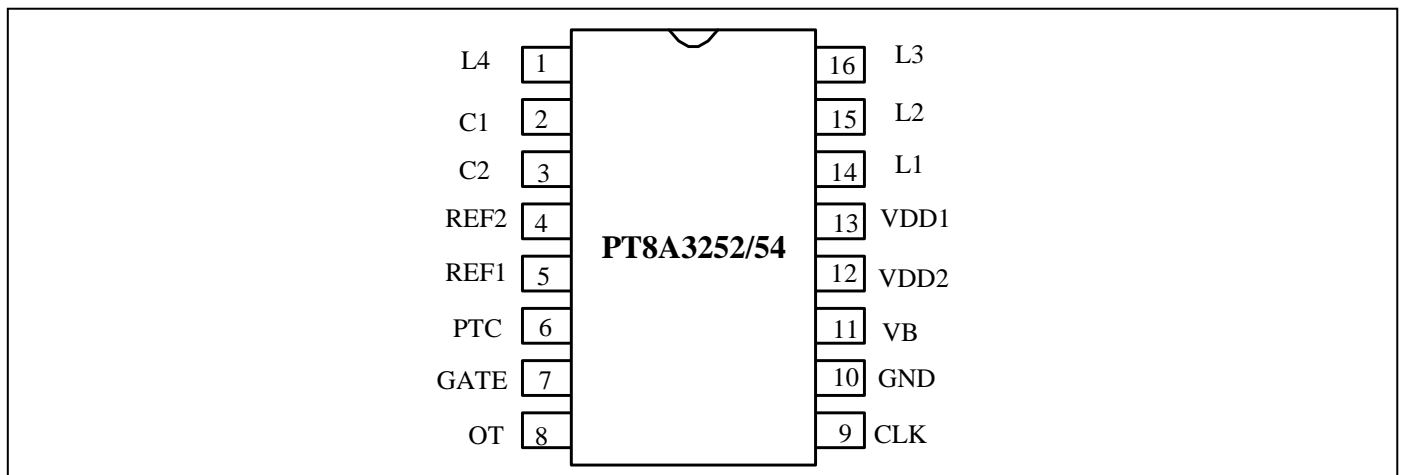

Pin Description

Pin No.	Pin Name	I/O	Pin Description
1	L4	I/O	Adjust input and LED output.
2	C1	O	LED scan common driver.
3	C2	O	LED scan common driver.
4	REF2	O	Reference 2 for internal comparator.
5	REF1	I	Reference 1 for internal comparator.
6	PTC	I	Temperature sensor input.
7	GATE	O	SCR trigger output, active high.
8	OT	O	Over heat output.
9	CLK	I	Clock input from power line.
10	GND	GND	Ground.
11	VB	O	PTC sampling power source.
12	VDD2	Power	Power.
13	VDD1	Power	Power.
14	L1	I/O	On/Off key input and LED output.
15	L2	I/O	Down key input and LED output.
16	L3	I/O	Up key input and LED output.

Block Diagram

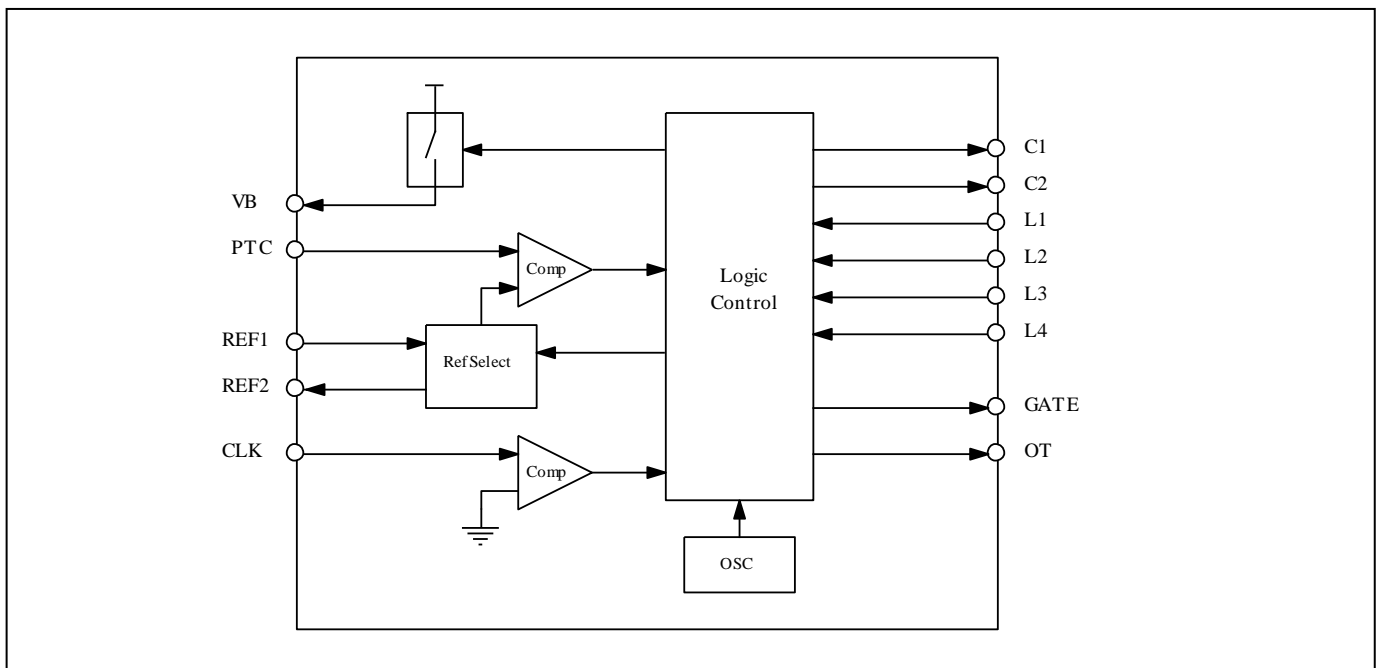

Maximum Ratings

Storage Temperature.....	-55°C to +150°C
Ambient Temperature with Power applied.....	-20°C to +85°C
Supply Voltage to Ground Potential (Input & V _{DD} Only).....	-0.5V to +6.5V
Supply Voltage to Ground Potential (Output s Only).....	-0.5V to +6.5V
DC Input Voltage.....	-0.5V to +6.5V
Input/Output Current.....	50mA
Input/Output Current (Pin VDD2, VB only).....	200mA
Power Dissipation.....	500mW

Note:

Stresses greater than those listed under MAXIMUM RATINGS may cause permanent damage to the device. This is a stress rating only and functional operation of the device at these or any other conditions above those indicated in the operational sections of this specification is not implied. Exposure to absolute maximum rating conditions for extended periods may affect reliability.

Recommended operation conditions

Sym	Parameter	Pin	Min	Typ	Max	Unit
VDD	Operating Voltage	VDD1, VDD2	4.0	5.0	6.0	V
T _A	Operating temperature	-	-20	-	85	°C

DC Input Electrical Characteristics

Symbol	Description	Test Conditions		Min	Type	Max	Unit
I _{IH}	Input high current	PIN: PTC, CLK	V _{IN} = V _{DD}	-	-	5	μA
		PIN: L1, L2, L3, L4	V _{IN} = V _{DD} (L1, L2, L3, L4 is of input)	-	-	5	
I _{IL}	Input low current	PIN: PTC, CLK	V _{IN} = GND	-	-	-5	μA
		PIN: L4	V _{IN} = GND (L4 is of input)	-	-	-5	
		PIN: L1, L2, L3	V _{DD} = 5.0V V _{IN} = 2.0V (L1, L2, L3 is of input)	-0.06	-	-0.20	mA
V _{IH}	Input High Voltage	PIN: L1, L2, L3	-	0.8 V _{DD}	-	-	V
V _{IL}	Input Low Voltage	PIN: L1, L2, L3	-	-	-	0.4 V _{DD}	V
V _{IT}	Input Threshold Voltage	VT1_Level	L4	2.8	3.3	3.8	V
		VT2_Level		1.1	1.6	2.1	V

DC Output Electrical Characteristics

Symbol	Description	Test Conditions		Min	Type	Max	Unit
I _{OH}	Output High Current	PIN: GATE	V _{DD} = 5.0V V _{out} = 2.5V	-15	-	-	mA
		PIN: OT	V _{DD} = 5.0V V _{out} = 4.5V	-3.0	-	-	
		PIN: L1, L2, L3	V _{DD} = 5.0V V _{out} = 4.5V	-3.0	-1	-1.2	
		PIN: C1	V _{DD} = 5.0V V _{out} = 4.5V	-3.0	-	-	
		PIN: L4	V _{DD} = 5.0V V _{out} = 4.5V	-3.0	-	-	
I _{OL}	Output Low Current	PIN: GATE	V _{DD} = 5.0V V _{out} = 0.5V	4.0	-	-	mA
		PIN: OT	V _{DD} = 5.0V V _{out} = 0.5V	4.0	-	-	
		PIN: C1, C2	V _{DD} = 5.0V V _{out} = 0.5V	4.0	-	-	
		PIN: L4	V _{DD} = 5.0V V _{out} = 0.5V	4.0	-	-	

Power Supply Characteristics

Symbol	Description	Test Conditions	Min	Type	Max	Unit
V _{POR}	Voltage of POR	-	1.5	-	2.5	V
I _{DD}	Current consumption	No loading, V _{DD} = 5.0V	-	-	400	μA
V _{DD}	Supply voltage	Control function normal	4.0	-	6.0	V
TPO _{off}	Power off timer	F _{CLK} = 50Hz	1.15	1.2	1.25	Hour

Temperature Control Characteristics

Symbol	Description	Test Conditions	Type	Unit
VT ₁₃₀	Threshold Voltage Level (130C)	VDD2=5.0V VREF2=0.7V VREF1=0~100%(VB-VREF2) Test GATE output about 50% heating power	0.467 VB-V _{REF2}	V
VT ₁₄₅	Threshold Voltage Level (145C)		0.477 VB-V _{REF2}	
VT ₁₆₀	Threshold Voltage Level (160C)		0.488 VB-V _{REF2}	
VT ₁₇₅	Threshold Voltage Level (175C)		0.497 VB-V _{REF2}	
VT ₁₉₀	Threshold Voltage Level (190C)		0.506 VB-V _{REF2}	
VOT ₂₅₀	Voltage Level of resistor net (250C)	VDD2=5.0V VREF2=0.7V VREF1=0~100%(VB-VREF2) When increase VPTC, test OT is just from "L" to "H"	0.539 VB-V _{REF2}	V

Functional Description

- **3 Input Buttons**

On/Off: This button will toggle Heating-on or Heating-off. Once heating-on, the level 1 of 130°C temperature setting always be selected.

Up: Temperature up adjustment button. Push Up-button once, the temperature setting increases one level until the highest level 5 is reached.

Down: Temperature down adjustment button. Push Down-button once, the temperature setting reduces one level until the lowest level 1 is reached.

- **5 LED Indicator (Internal)**

LED1: 130°C temperature setting (level 1)

LED2: 145°C temperature setting (level 2)

LED3: 160°C temperature setting (level 3)

LED4: 175°C temperature setting (level 4)

LED5: 190°C temperature setting (level 5)

Note: The temperature range can be adjusted from 100°C to 250°C by external series resistance.

- **Reset**

After power on the chip will be reset by internal POR circuit, LED1~ LED5 are all disabled. GATE and OT PIN output are low level.

- **Timer (only for PT8A3252)**

Once IC enters Heating-on state, internal timer starts to count. It timeouts and device will stop heating automatically after 216000 clock period, ie. 1 hour for 60Hz and 1.2 hour for 50Hz.

- **Over-Heat Protection**

Once heater loses control and reaches to 250°C, the Over-Heat protection function will be activated by driving one SCR to melt the fuse immediately.

Application Circuit

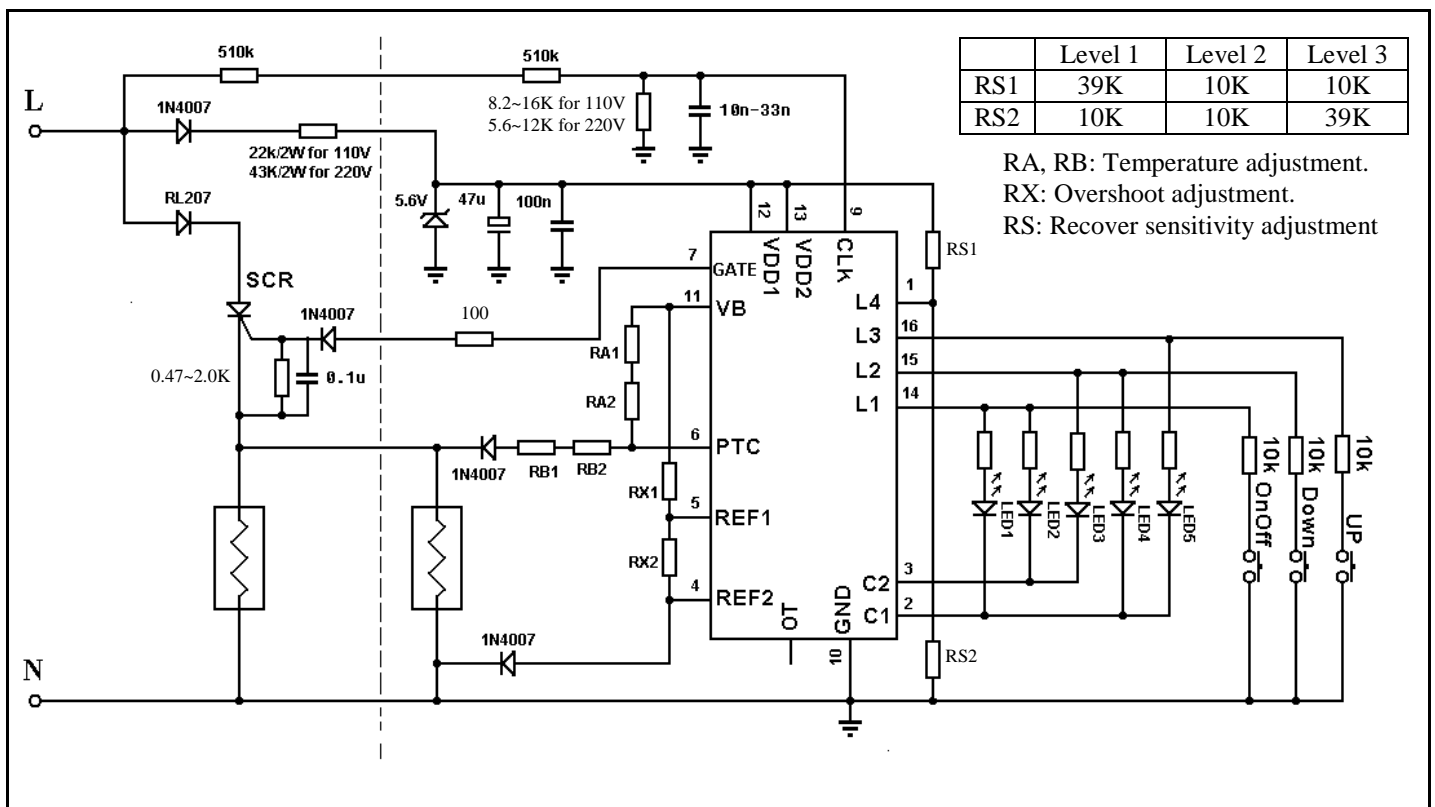

Mechanical Information

PE (Lead free DIP-16)

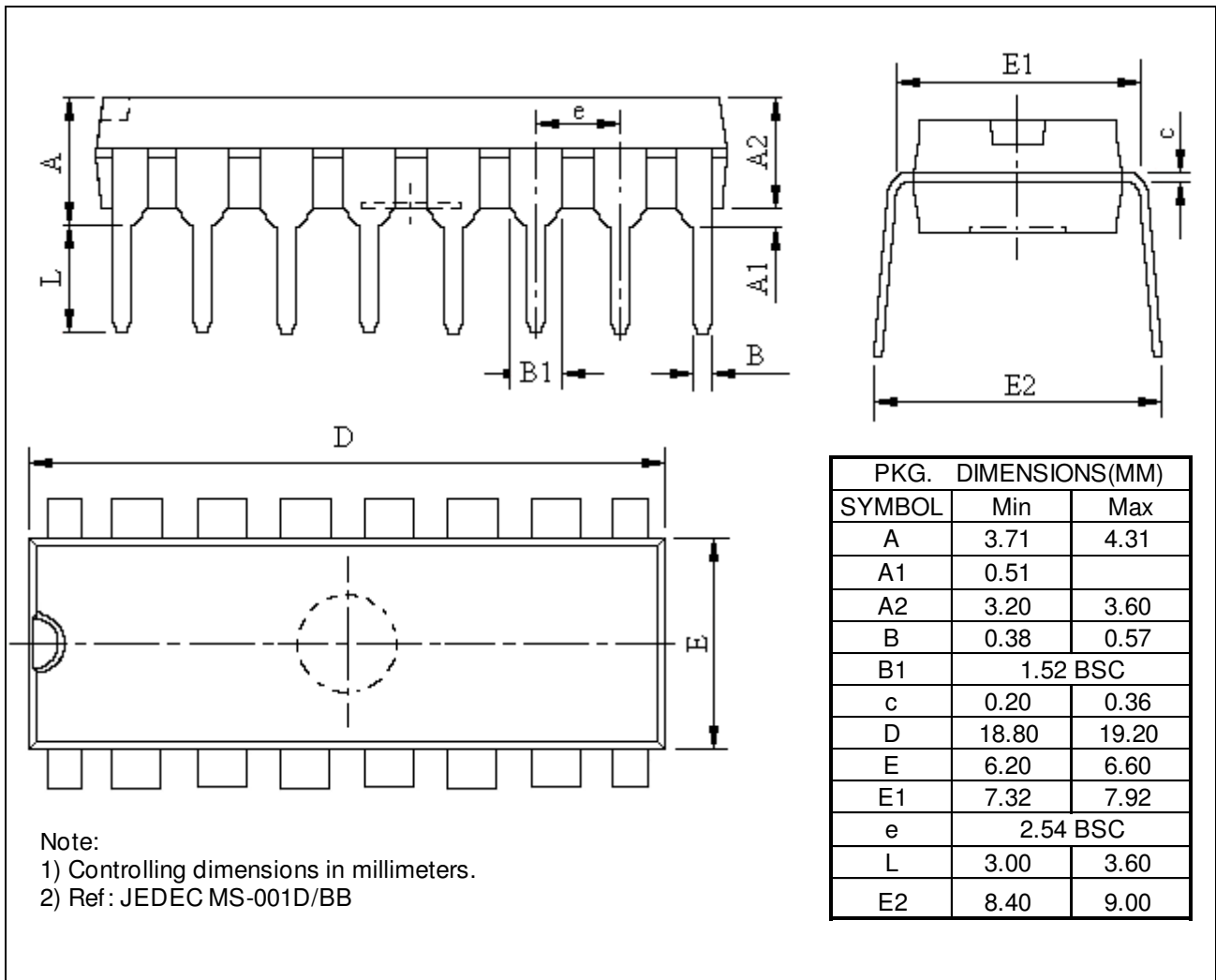

WE (Lead free SOIC-16)

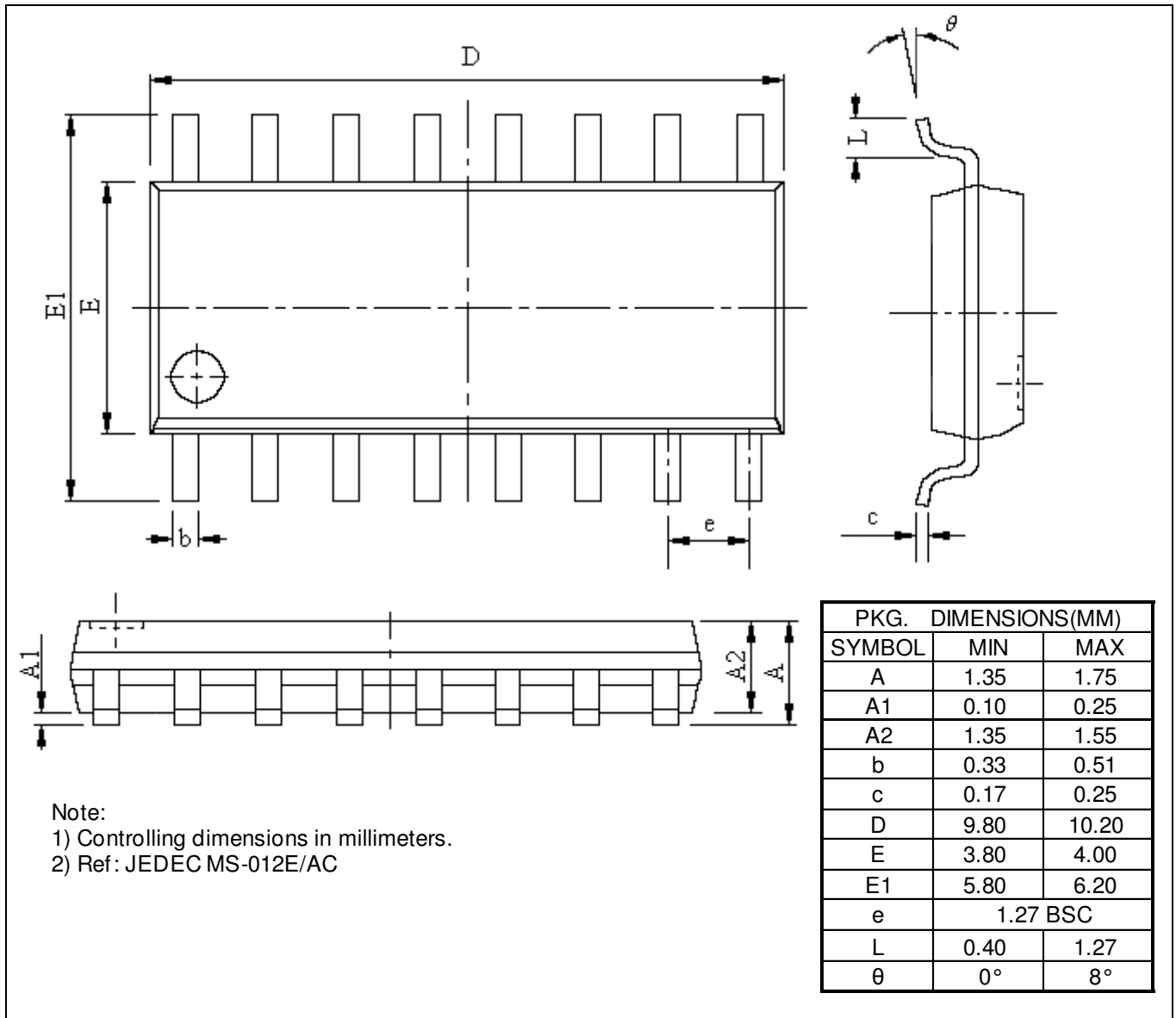

Ordering Information

Ordering No.	Package Code	Package
PT8A3252PE	P	Lead free DIP-16
PT8A3252WE	W	Lead free SOIC-16
PT8A3254PE	P	Lead free DIP-16
PT8A3254WE	W	Lead free SOIC-16

Note:

- E = Pb-free
- Adding X Suffix= Tape/Reel

Pericom Semiconductor Corporation • 1-800-435-2336 • www.pericom.com

Pericom reserves the right to make changes to its products or specifications at any time, without notice, in order to improve design or performance and to supply the best possible product. Pericom does not assume any responsibility for use of any circuitry described other than the circuitry embodied in Pericom product. The company makes no representations that circuitry described herein is free from patent infringement or other rights, of Pericom.