

Ceramic Heating Controller

Features

- High watt density Alumina Heaters
- High triggering current and double pulse trigger for SCR
- Enhanced MHP Algorithm for Quickly Heating-Up and Quickly Lost-Heat-Recover
- Uniform Heat to Maintain Constant Temperature
- Adjustable to fit wide range heating plates
- Adjustable to different Thermal Coefficient of Resistively
- Full compensation and insensitive to environment temperature
- 6 Heat Temperature Settings
- Auto power off for PT8A3251
- Over Temperature protection
- Package: DIP-16 and SOIC-16 package

Description

The PT8A3251/53 is a Mix-signal CMOS chip designed for ceramic heating controller. The chip offers 6 different default heat temperature settings including 150°C, 170°C, 185°C, 200°C, 215°C, 230°C. And the temperature range can be adjusted through external series resistance. The PT8A3251 has an internal timer; it timeouts and device will stop heating automatically after 216000 clock period, ie. 1 hour for 60Hz and 1.2 hour for 50Hz. The PT8A3251/53 also has over temperature protection function. The chip is enclosed in Lead free DIP-16 and SOIC-16.

Applications

- Ceramic Heating Controller

Pin Configuration

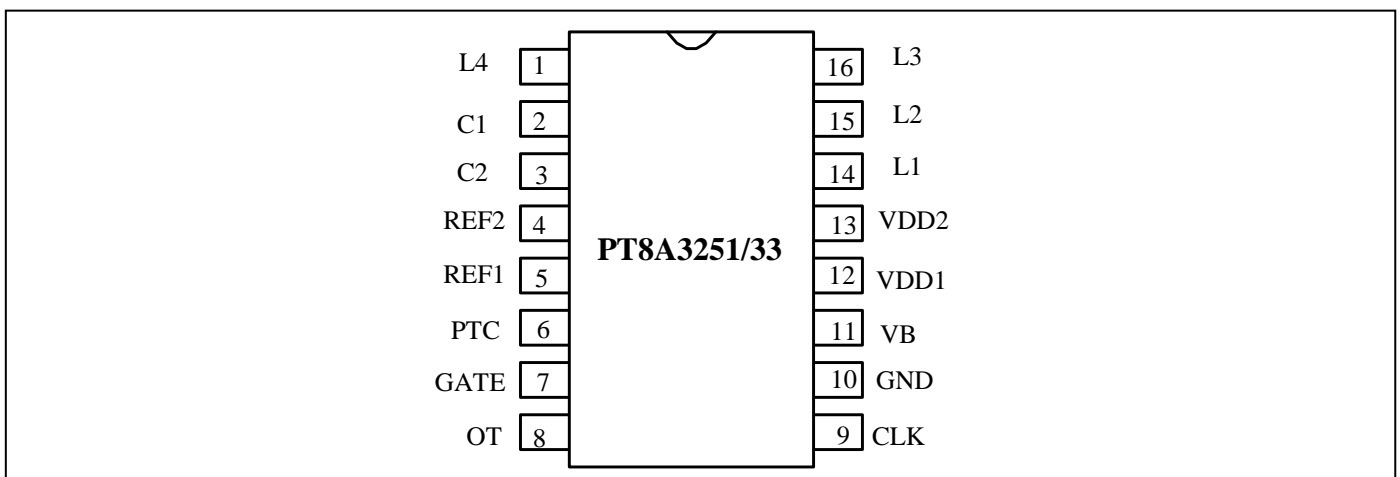

Pin Description

Pin No.	Pin Name	I/O	Pin Description
1	L4	I/O	Adjust Lost-heat-recover input and LED ON/OFF cathode output.
2	C1	O	LED scan common driver.
3	C2	O	LED scan common driver.
4	REF2	I	Reference 2 for internal comparator.
5	REF1	I	Reference 1 for internal comparator.
6	PTC	I	Temperature sensor input.
7	GATE	O	SCR trigger output, active high.
8	OT	O	Over heat output, active high.
9	CLK	I	Clock input from power line.
10	GND	GND	Ground.
11	VB	O	PTC sampling power source.
12	VDD1	Power	Power.
13	VDD2	Power	Power.
14	L1	I/O	On/Off key input and LED anode output.
15	L2	I/O	Down key input and LED anode output.
16	L3	I/O	Up key input and LED anode output.

Block Diagram

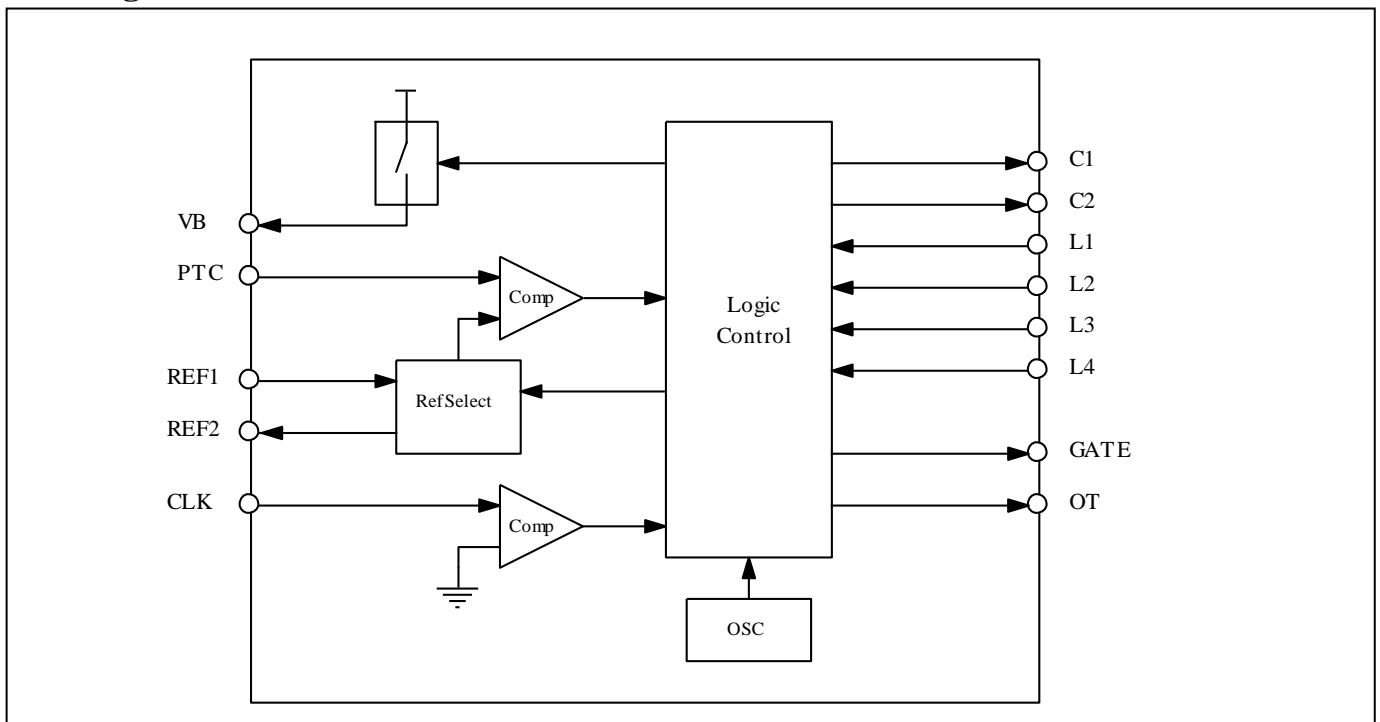

Maximum Ratings

Storage Temperature.....	-55°C to +150°C
Ambient Temperature with Power applied.....	-40°C to +85°C
Supply Voltage to Ground Potential (Input & V _{DD} Only).....	-0.5V to +6.5V
Supply Voltage to Ground Potential (Output s Only).....	-0.5V to +6.5V
DC Input Voltage.....	-0.5V to +6.5V
Input/Output Current.....	50mA
Input/Output Current (Pin VDD2, VB only).....	200mA
Power Dissipation.....	500mW

Note:

Stresses greater than those listed under MAXIMUM RATINGS may cause permanent damage to the device. This is a stress rating only and functional operation of the device at these or any other conditions above those indicated in the operational sections of this specification is not implied. Exposure to absolute maximum rating conditions for extended periods may affect reliability.

Recommended operation conditions

Sym	Parameter	Pin	Min	Typ	Max	Unit
VDD	Operating Voltage	VDD1, VDD2	4.0	5.0	5.5	V
T _A	Operating temperature	-	-20	-	85	°C

DC Input Electrical Characteristics

Sym	Description	Test Conditions		Min	Type	Max	Unit
I _{IH}	Input high current	PIN: PTC, CLK	V _{IN} = V _{DD}	-	-	5	μA
		PIN: L1, L2, L3, L4	V _{IN} = V _{DD} (L1, L2, L3, L4 is of input)	-	-	5	
I _{IL}	Input low current	PIN: PTC, CLK	V _{IN} = GND	-	-	-5	μA
		PIN: L4	V _{IN} = GND (L4 is of input)	-	-	-5	
		PIN: L1, L2, L3	V _{DD} = 5.0V V _{IN} = 2.0V (L1, L2, L3 is of input)	-0.16	-0.20	-0.24	mA
V _{IH}	Input High Voltage	PIN: L1, L2, L3	-	0.8 V _{DD}	-	-	V
V _{IL}	Input Low Voltage	PIN: L1, L2, L3	-	-	-	0.4 V _{DD}	V
V _{IT}	Input Threshold Voltage	VT1_Level	L4	2.8	3.3	3.8	V
		VT2_Level		1.1	1.6	2.1	V

DC Output Electrical Characteristics

Sym	Description	Test Conditions		Min	Type	Max	Unit
I _{OH}	Output High Current	PIN: GATE	V _{DD} = 5.0V V _{out} = 4.5V	-3.0	-	-	mA
		PIN: OT	V _{DD} = 5.0V V _{out} = 4.5V	-3.0	-	-	
		PIN: L1, L2, L3	V _{DD} = 5.0V V _{out} = 2.2V	-0.8	-1	-1.2	
		PIN:C1	V _{DD} = 5.0V V _{out} = 4.5V	-3.0	-	-	
		PIN:L4	V _{DD} = 5.0V V _{out} = 4.5V	-3.0	-	-	
I _{OL}	Output Low Current	PIN: GATE	V _{DD} = 5.0V V _{out} = 0.5V	4.0	-	-	mA
		PIN: OT	V _{DD} = 5.0V V _{out} = 0.5V	4.0	-	-	
		PIN: C1, C2	V _{DD} = 5.0V V _{out} = 0.5V	4.0	-	-	
		PIN: L4	V _{DD} = 5.0V V _{out} = 2.8V	0.8	1	1.2	

Power Supply Characteristics

Sym	Description	Test Conditions	Min	Type	Max	Unit
V _{POR}	Voltage of POR	-	1.5	-	2.5	V
I _{DD}	Current consumption	No loading, V _{DD} = 5.0V	-	-	400	μA
V _{DD}	Supply voltage	Control function normal	3.5	-	5.5	V
TPO _{off}	Power off timer	F _{CLK} = 50Hz	1.15	1.2	1.25	Hour

Temperature Control Characteristics

Sym	Description	Test Conditions	Type	Unit
VT ₁₅₀	Threshold Voltage Level (150C)	VDD2=5.0V VREF2=0.7V VREF1=0~100%(VB-VREF2) Test GATE output about 50% heating power	0.482 VB-V _{REF2}	V
VT ₁₇₀	Threshold Voltage Level (170C)		0.494 VB-V _{REF2}	
VT ₁₈₅	Threshold Voltage Level (185C)		0.503 VB-V _{REF2}	
VT ₂₀₀	Threshold Voltage Level (200C)		0.512 VB-V _{REF2}	
VT ₂₁₅	Threshold Voltage Level (215C)		0.520 VB-V _{REF2}	
VT ₂₃₀	Threshold Voltage Level (230C)		0.529 VB-V _{REF2}	
VOT ₂₈₀	Voltage Level of resistor net (280C)		VDD2=5.0V VREF2=0.7V VREF1=0~100%(VB-VREF2) When increase VPTC, test OT is just from "L" to "H"	
VT _{150H}	Heat-up Threshold Voltage Level (150C)	VDD2=5.0V VREF2=0.7V VREF1=100%(VB-VREF2) Test GATE output about 50% heating power	VT ₁₅₀ +1.9%(VB-V _{REF2})	V
VT _{170H}	Heat-up Threshold Voltage Level (170C)		VT ₁₇₀ +1.7%(VB-V _{REF2})	
VT _{185H}	Heat-up Threshold Voltage Level (185C)		VT ₁₈₅₀ +1.6%(VB-V _{REF2})	
VT _{200H}	Heat-up Threshold Voltage Level (200C)		VT ₂₀₀ +1.5%(VB-V _{REF2})	
VT _{215H}	Heat-up Threshold Voltage Level (215C)		VT ₂₁₅ +1.4%(VB-V _{REF2})	
VT _{230H}	Heat-up Threshold Voltage Level (230C)		VT ₂₃₀ +1.3%(VB-V _{REF2})	

Functional Description

- 3 Input Buttons**

On/Off: This button will toggle Heating-on or Heating-off. Once heating-on, the level 4 of 200°C temperature setting always be selected.

Up: Temperature up adjustment button. Push Up-button once, the temperature setting increases one level until the highest level 6. Then after, Level 6 will be kept.

Down: Temperature down adjustment button. Push Down-button once, the temperature setting reduces one level until the lowest level 1. Then after, Level 1 will be kept.
- 7 LED Indicator**

LED1: Heating-on or Heating-off

LED2: 150°C temperature setting (level 1)

LED3: 170°C temperature setting (level 2)

LED4: 185°C temperature setting (level 3)

LED5: 200°C temperature setting (level 4)

LED6: 215°C temperature setting (level 5)

LED7: 230°C temperature setting (level 6)

Note: The temperature range can be adjusted by external series resistance.
- Reset**

After power on the chip will be reset by POR circuit, LED1~ LED7 are all disabled. GATE and OT PIN output are low level.
- Timer (Only for PT8A3251)**

Once IC enters Heating-on state, internal timer starts to count. It timeouts and device will stop heating automatically after 216000 clock period, ie. 1 hour for 60Hz and 1.2 hour for 50Hz.
- Over-Heat Protection**

Once heater loses control and reaches to 280°C, the Over-Heat protection function will be activated by driving one SCR to melt the fuse immediately.

Application Circuit

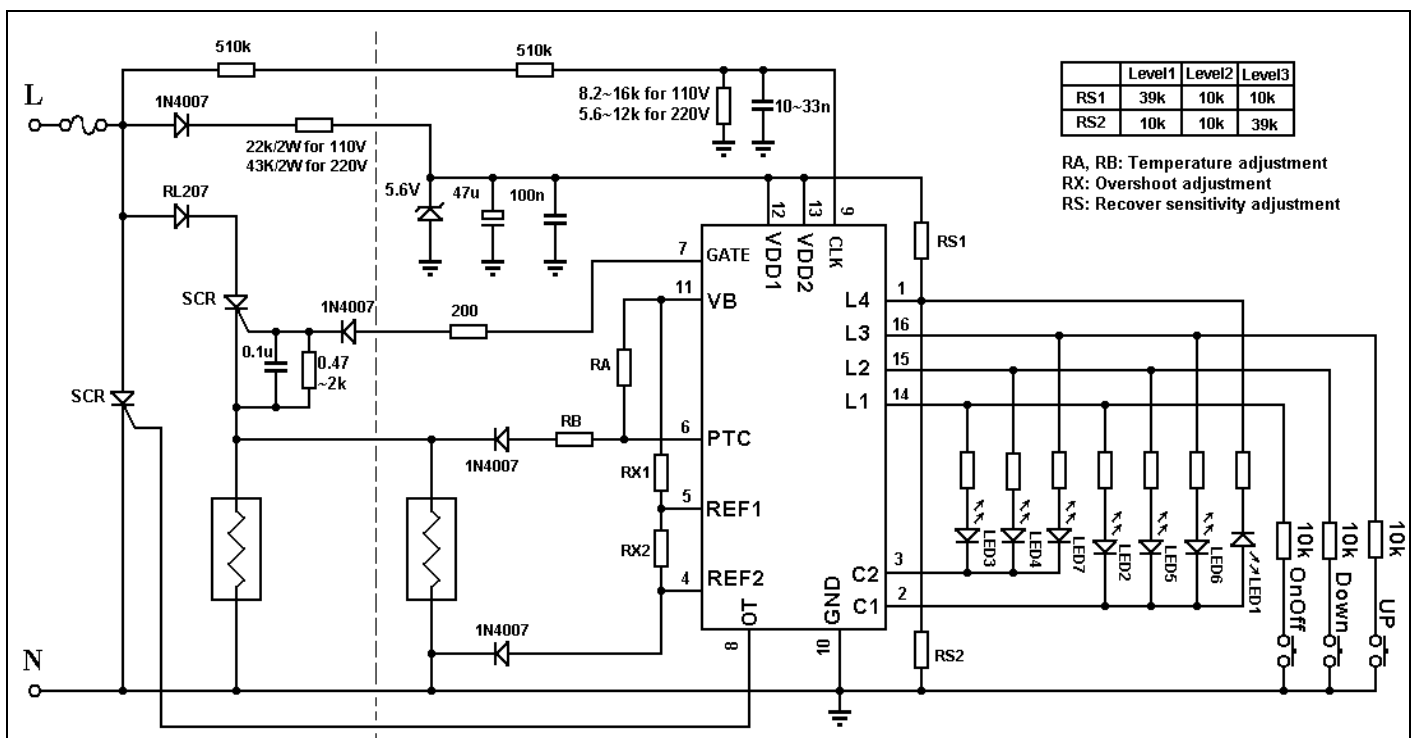

Mechanical Information

PE (DIP-16)

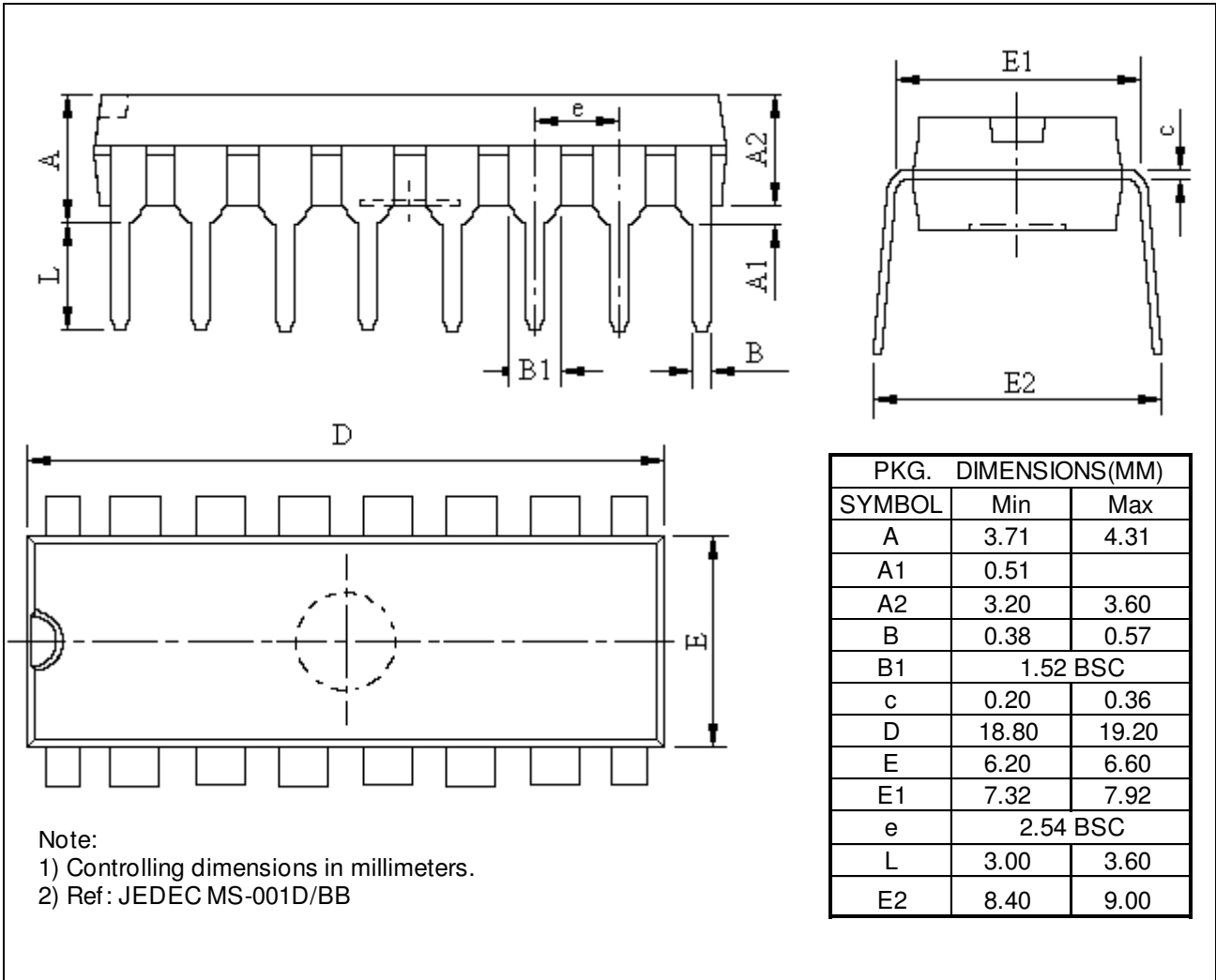

WE (SOIC-16)

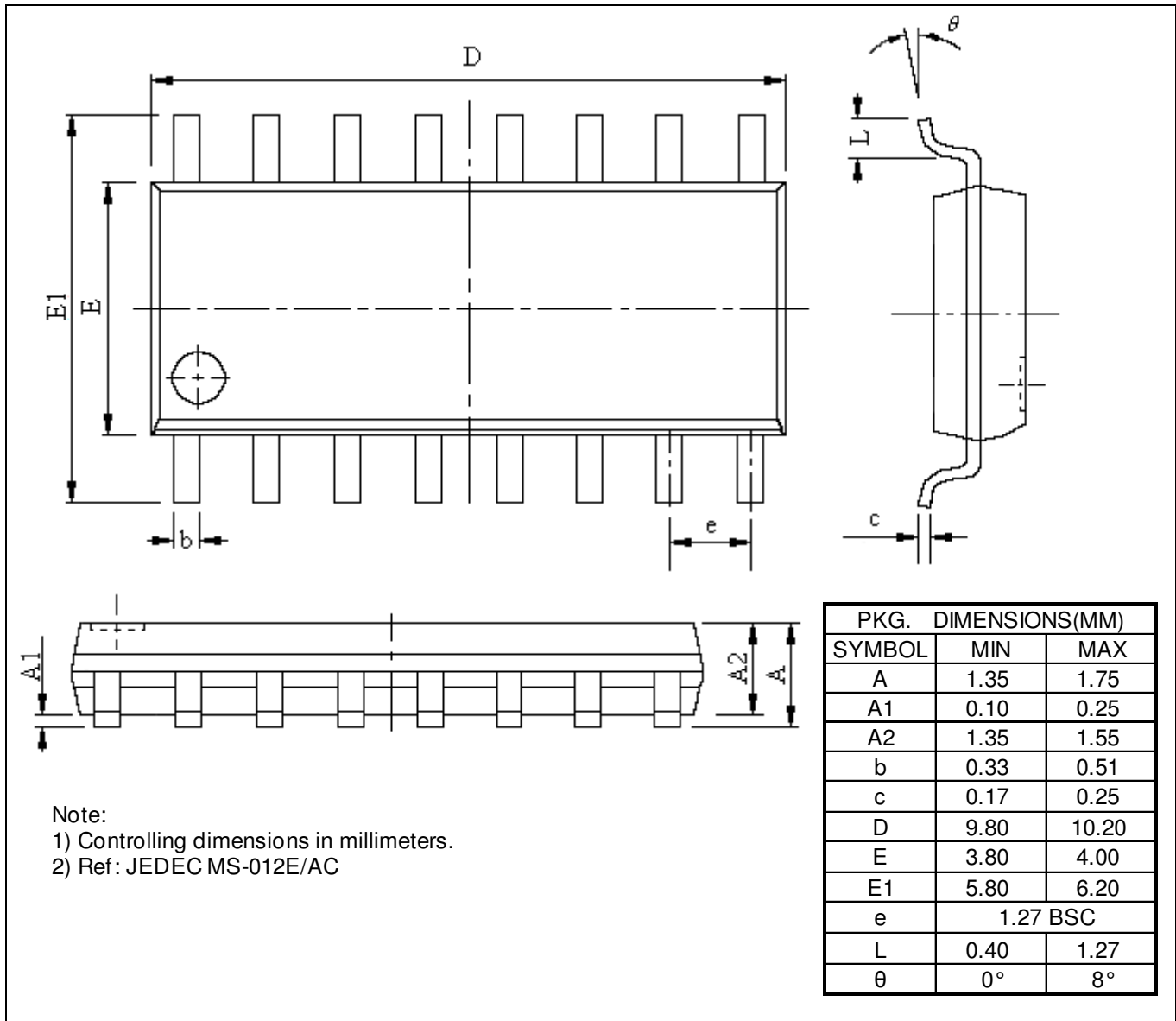

Ordering Information

Ordering No.	Package Code	Package
PT8A3251PE	P	Lead free DIP-16
PT8A3251WE	W	Lead free SOIC-16
PT8A3253PE	P	Lead free DIP-16
PT8A3253WE	W	Lead free SOIC-16

Note:

- E = Pb-free
- Adding X Suffix= Tape/Reel

Pericom Semiconductor Corporation • 1-800-435-2336 • www.pericom.com

Pericom reserves the right to make changes to its products or specifications at any time, without notice, in order to improve design or performance and to supply the best possible product. Pericom does not assume any responsibility for use of any circuitry described other than the circuitry embodied in Pericom product. The company makes no representations that circuitry described herein is free from patent infringement or other rights, of Pericom.