

3.3V PECL High Frequency VCXO

PR



7.0 x 5.0mm Ceramic SMD

Product Features

- Frequencies available up to 800 MHz
- <3ps RMS jitter
- Designed for standard reflow and washing techniques
- Pb-free & RoHS/Green compliant

Product Description

The PR Series voltage controlled crystal oscillator achieves superb temperature stability over a broad range of operating conditions and frequencies. The device is constructed with a hermetically sealed quartz crystal resonator exhibiting a high-Q for exceptional performance. The device, available on tape and reel, is contained in a 7.0 x 5.0mm surface mount ceramic package.

Applications

The PR Series VCXO is an ideal component in phase locked loop circuits that perform clock smoothing, clock/data recovery, or frequency translation and card synchronization functions, such as:

- SONET/SDH/DWDM/E4 timing control & line cards
- 1 & 10 Gigabit Ethernet and FibreChannel
- Satellite, microwave and cellular base stations
- Server & Storage platforms

Package:

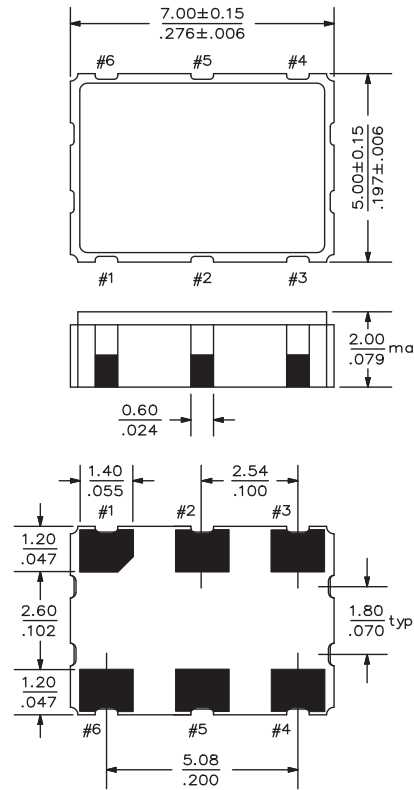

Recommended Land Pattern:

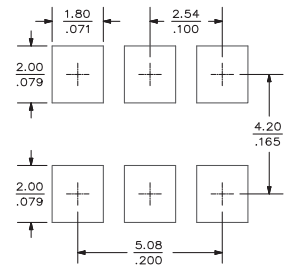

Pin Functions:

Pin	Function
1	Voltage Control
2	OE or NC
3	Ground
4	Q Output
5	\bar{Q} Output
6	V _{CC}

Part Ordering Information:

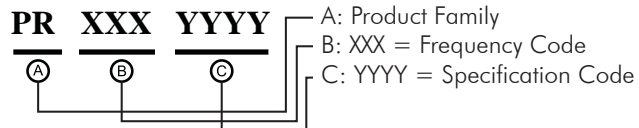

Following the above format, Saronix-eCera part numbers will be assigned upon confirmation of exact customer requirements.

Legacy Ordering Information - For Reference Only:

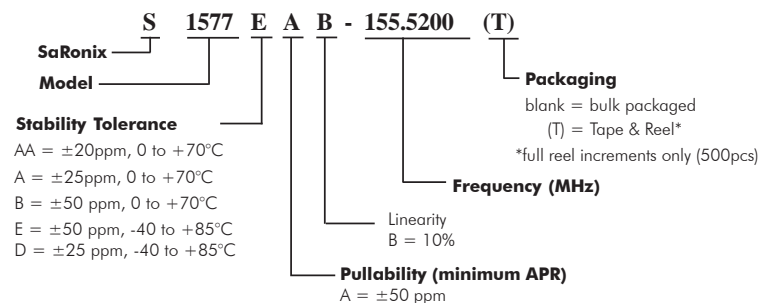

3.3V PECL High Frequency VCXO PR

PR Series Voltage Controlled Crystal Oscillator (VCXO) Legacy S1577 Series | 7.0 x 5.0mm

Electrical Performance

Parameter	Min.	Typ.	Max.	Units	Notes
Output Frequency (F _N)	19.44		800	MHz	As specified
Supply Voltage	3.14	3.3	3.46	V	
Supply Current			100	mA	
Frequency Stability			±20 to ±50	ppm	See Note 1 below
Operating Temperature Range	-40		+85	°C	As specified
Output Logic 0, V _{OL}			V _{CC} - 1.620	V	0 to +85°C
Output Logic 1, V _{OH}	V _{CC} - 1.025			V	0 to +85°C
Output Load	50Ω to V _{CC} - 2V				output requires termination
Duty Cycle	45		55	%	measured V _{DD} - 1.3 VDC
Rise and Fall Time		0.6	1.5	ns	measured 20/80% of waveform
Jitter, Phase		2.5	4	ps RMS (1-σ)	12kHz to 20MHz frequency band
Jitter, Accumulated		5	10	ps RMS (1-σ)	10,000 adjacent periods

Notes:

- As specified. Stability includes all combinations of operating temperature, load changes, rated input (supply) voltage changes, shock and vibration. Stability is inclusive of 5 years aging at 40°C average effective ambient temperature for ordering options A, B, D, E.
- For specifications other than those listed, please contact sales.

Frequency Modulation Function

Parameter	Min.	Typ.	Max.	Units	Notes
Absolute Pull Range (APR)	±50			ppm	See #1 below
Control Voltage Range	0.3		3.0	V _{DC}	As rated
Center Control Voltage	1.32	1.65	1.98	V	For RMT center frequency
Monotonic Linearity			10	%	Positive transfer slope
Input Impedance	50			kΩ	Control voltage pin
Modulation Bandwidth	10			kHz	-3dB

Notes:

- APR is relative to the nominal output frequency F_N; APR is inclusive (net) of frequency deviation due to stability.

Output Enable / Disable Function

Parameter	Min.	Typ.	Max.	Units	Notes
Input Voltage, Output Enable (pin 2)			V _{OL}	V	or Open
Input Voltage, Output Disable (pin2)	V _{OH}			V	Q and Q outputs disable to High Impedance

Absolute Maximum Ratings

Parameter	Min.	Typ.	Max.	Units	Notes
Storage Temperature	-55		+125	°C	

Output Waveform

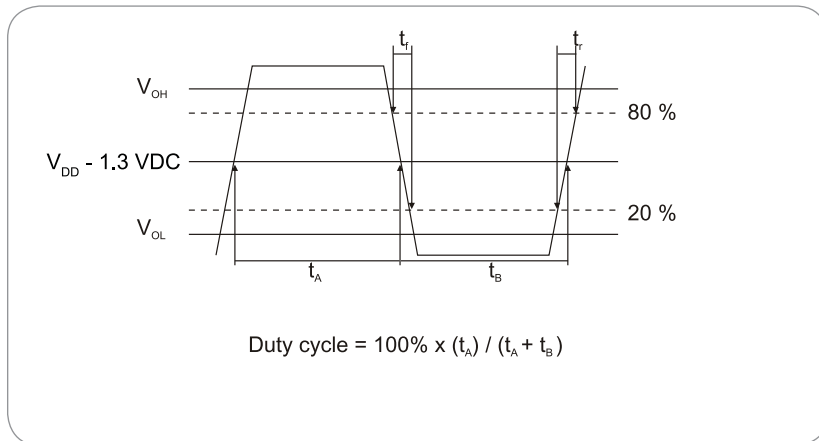

Test Circuit

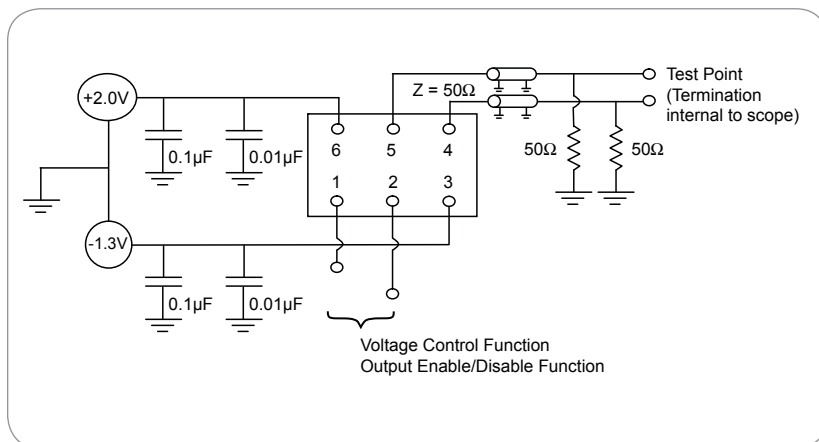

3.3V PECL High Frequency VCXO PR

PR Series Voltage Controlled Crystal Oscillator (VCXO)
Legacy S1577 Series | 7.0 x 5.0mm

Reflow Soldering Profile

As per IPC/JEDEC J-STD-020C

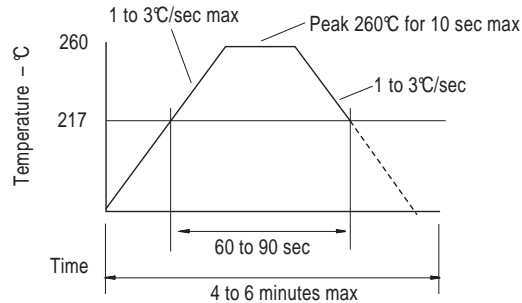

Mechanical Drawing

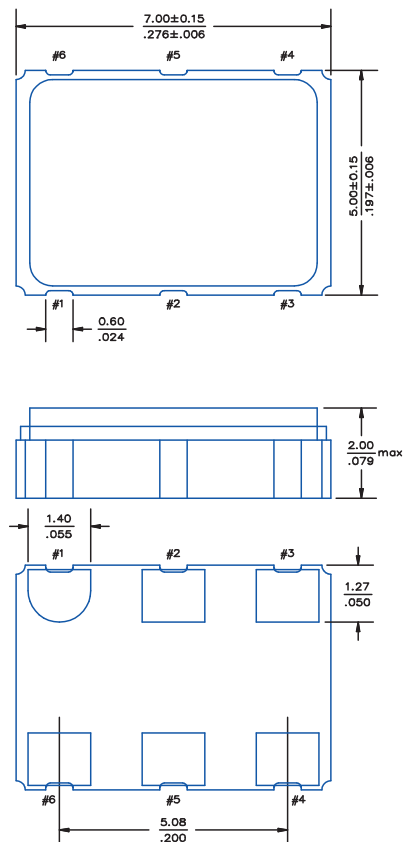

Reliability Test Ratings

This product is rated to meet the following test conditions:

Type	Parameter	Test Condition
Mechanical	Shock	MIL-STD-883, Method 2002, Condition B
Mechanical	Solderability	JESD22-B102-D Method 2 (Preconditioning E)
Mechanical	Terminal strength	MIL-STD-883, Method 2004, Condition D
Mechanical	Gross leak	MIL-STD-883, Method 1014, Condition C
Mechanical	Fine leak	MIL-STD-883, Method 1014, Condition A2 ($R_1 = 2 \times 10^{-8}$ atm cc/s)
Mechanical	Solvent resistance	MIL-STD-202, Method 215
Environmental	Thermal shock	MIL-STD-883, Method 1011, Condition A
Environmental	Moisture resistance	MIL-STD-883, Method 1004
Environmental	Vibration	MIL-STD-883, Method 2007, Condition A
Environmental	Resistance to soldering heat	J-STD-020C Table 5-2 Pb-free devices (2 cycles max)