

## High Performance Differential Fanout Buffer

### Features

- 10 differential outputs with 2 banks
- User configurable output signaling standard for each bank: LVDS or LVPECL or HCSL
- LVC MOS reference output up to 200MHz
- Up to 1.5GHz output frequency for differential outputs
- Ultra low additive phase jitter: < 0.03 ps (typ) (differential 156.25MHz, 12KHz to 20MHz integration range)
- Selectable reference inputs support either single-ended or differential or Xtal
- Low skew between outputs within banks (<40ps)
- Low delay from input to output (Tpd typ. < 1.5ns)
- Separate Input output supply voltage for level shifting
- 2.5V / 3.3V power supply
- Industrial temperature support
- TQFN-48 package

### Description

The PI6C49S1510 is a high performance fanout buffer device which supports up to 1.5GHz frequency. It also integrates a unique feature with user configurable output signaling standards on per bank basis which provide great flexibilities to users. The device also uses Pericom's proprietary input detection technique to make sure illegal input conditions will be detected and reflected by output states. This device is ideal for systems that need to distribute low jitter clock signals to multiple destinations.

### Applications

- Networking systems including switches and Routers
- High frequency backplane based computing and telecom platforms

### Block Diagram

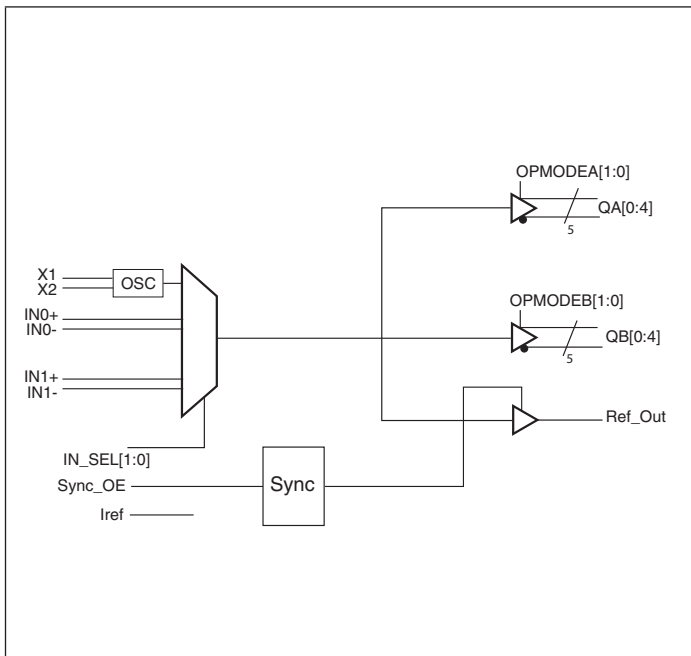

### Pin Configuration (48-Pin TQFN)

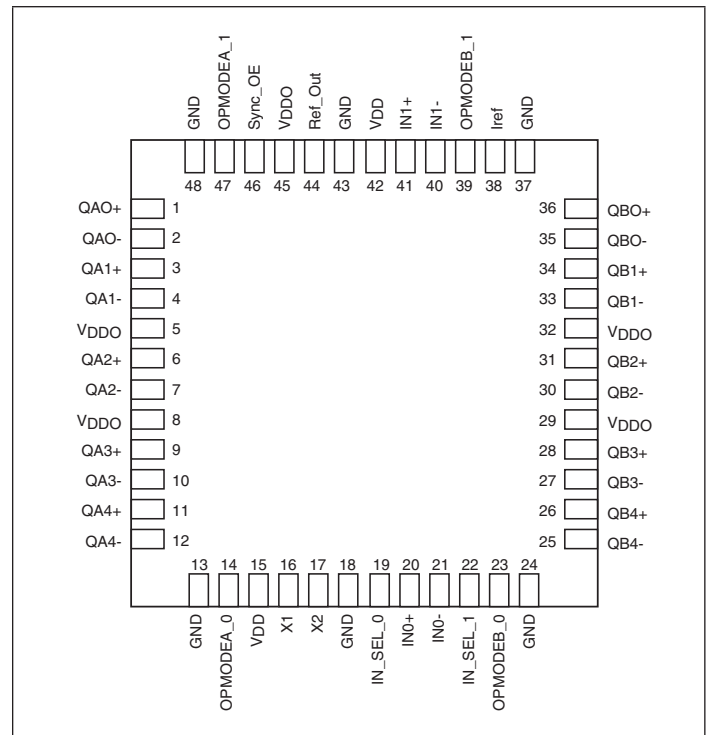

### Pinout Table

Pin #	Pin Name	Type		Description
1,2	QA0+ QA0-	Output		Bank A differential output pair 0. Pin selectable LVPECL/LVDS/HCSL interface levels.
3,4	QA1+	Output		Bank A differential output pair 1. Pin selectable LVPECL/LVDS/HCSL interface levels.
	QA1-			
5,8,29,32,45	VDDO	Power		Power supply pins for IO
6,7	QA2+	Output		Bank A differential output pair 2. Pin selectable LVPECL/LVDS/HCSL interface levels.
	QA2-			
9,10	QA3+	Output		Bank A differential output pair 3. Pin selectable LVPECL/LVDS/HCSL interface levels.
	QA3-			
11,12	QA4+	Output		Bank A differential output pair 4. Pin selectable LVPECL/LVDS/HCSL interface levels.
	QA4-			
13,18,24,37,43,48	GND	Power		Power supply ground
14,47	OPMODEA	Input	Pulldown	Output mode select for Bank A. See Table 2 for functions, LVCMOS/LVTTL interface levels
15,42	V <sub>DD</sub>	Power		Power supply pins
16	X1	Input		XTAL input
17	X2	Output		XTAL output
19,22	IN_SEL	Input	Pulldown	Input clock select. See Table 1 for function. LVCMOS/LVTTL interface levels.
20	IN0+	Input	Pulldown	Reference input 0
21	IN0-	Input	Pull-up/ Pulldown	Inverted reference input 0, internal bias to V <sub>DD</sub> /2
23,39	OPMODEB	Input	Pulldown	Output mode select for Bank B. See Table 2 for functions, LVCMOS/LVTTL interface levels
26,25	QB4+	Output		Bank B differential output pair 4. Pin selectable LVPECL/LVDS/HCSL interface levels.
	QB4-			
28,27	QB3+	Output		Bank B differential output pair 3. Pin selectable LVPECL/LVDS/HCSL interface levels.
	QB3-			
31,30	QB2+	Output		Bank B differential output pair 2. Pin selectable LVPECL/LVDS/HCSL interface levels.
	QB2-			
34,33	QB1+	Output		Bank B differential output pair 1. Pin selectable LVPECL/LVDS/HCSL interface levels.
	QB1-			

### Pinout Table (Continued..)

Pin #	Pin Name	Type		Description
36,35	QB0+	Output		Bank B differential output pair 0. Pin selectable LVPECL/LVDS/HCSL interface levels.
	QB0-			
38	Iref	Output		A fixed precision resistor (475ohm) from this pin to ground provides a reference current.
40	IN1-	Input	Pull-up/ Pulldown	Inverted reference input, internal bias to $V_{DD}/2$
41	IN1+	Input	Pulldown	Reference input 1
44	Ref_Out	Output		Reference output, CMOS
46	Sync_OE	Input		Synchronous output enable for Ref_Out, see Table 3 for functions

### Function Table

Table 1: Input select function

IN_SEL [1]	IN_SEL [0]	Function
0	0	IN0 is the selected reference input
0	1	IN1 is the selected reference input
1	X	XTAL is the selected input

Table 2: Output Mode select function

OPMODEA/B [1]	OPMODEA/B [0]	Output Bank A / Bank B Mode
0	0	LVPECL
0	1	LVDS
1	0	HCSL
1	1	Hi-Z

Table 3: Reference output enable function

Sync_OE	Ref_Out
0	Hi-Z
1	Output enabled

Table 4: Illegal input level function

Input illegal status	Output status
Input open	Logic Low
Input both high	Logic Low
Input both low	Logic Low

**Maximum Ratings** (Above which the useful life may be impaired. For user guidelines, not tested)

Storage temperature.....	-55 to +150°C
Supply Voltage to Ground Potential ( $V_{DD}$ ).....	-0.5 to +4.6V
Inputs (Referenced to GND) .....	-0.5 to $V_{DD}+0.5V$
Clock Output (Referenced to GND).....	-0.5 to $V_{DD}+0.5V$
Soldering Temperature (Max of 10 seconds) .....	+260°C
Latch up .....	200mA
EDS Protection (Input) .....	2000 V min (HBM)

**Note:**

Stresses greater than those listed under MAXIMUM RATINGS may cause permanent damage to the device. This is a stress rating only and functional operation of the device at these or any other conditions above those indicated in the operational sections of this specification is not implied. Exposure to absolute maximum rating conditions for extended periods may affect reliability.

**Power Supply Characteristics and Operating Conditions**

Symbol	Parameter	Test Condition	Min.	Typ.	Max.	Units
$V_{DD}$	Core Supply Voltage		2.375		3.465	V
$V_{DDO}$	Output Supply Voltage		2.375		3.465	V
$I_{DD}$	Core Power Supply Current			90	120	mA
$I_{DDO}$	Output Power Supply Current	All LVPECL outputs unloaded		110	145	
		All LVDS outputs loaded		110	125	
		All HCSL outputs unloaded		70	90	
$T_A$	Ambient Operating Temperature		-40		85	°C

**DC Electrical Specifications - Differential Inputs**

Symbol	Parameter		Min.	Typ.	Max.	Units
$I_{IH}$	Input High current	Input = $V_{DD}$			150	uA
$I_{IL}$	Input Low current	Input = GND	-150			uA
$C_{IN}$	Input capacitance			3		PF
$V_{IH}$	Input high voltage				$V_{DD}+0.3$	V
$V_{IL}$	Input low voltage		-0.3			V
$V_{ID}$	Input Differential Amplitude PK-PK		0.15		$V_{DD}-0.85$	V
$V_{CM}$	Common mode input voltage		GND + 0.5		$V_{DD}-0.85$	V

### DC Electrical Specifications - LVCMOS Inputs

Symbol	Parameter	Conditions	Min.	Typ.	Max.	Units
I <sub>IH</sub>	Input High current	Input = V <sub>DD</sub>			150	uA
I <sub>IL</sub>	Input Low current	Input = GND	-150			uA
V <sub>IH</sub>	Input high voltage	V <sub>DD</sub> =3.3V	2.0		V <sub>DD</sub> +0.3	V
V <sub>IL</sub>	Input low voltage	V <sub>DD</sub> =3.3V	-0.3		0.8	V
V <sub>IH</sub>	Input high voltage	V <sub>DD</sub> =2.5V	1.7		V <sub>DD</sub> +0.3	V
V <sub>IL</sub>	Input low voltage	V <sub>DD</sub> =2.5V	-0.3		0.7	V

### DC Electrical Specifications- LVPECL Outputs

Parameter	Description	Conditions	Min.	Typ.	Max.	Units
V <sub>OH</sub>	Output High voltage		V <sub>DD</sub> -1.4		V <sub>DD</sub> -0.9	V
V <sub>OL</sub>	Output Low voltage		V <sub>DD</sub> -2.1		V <sub>DD</sub> -1.7	V

### DC Electrical Specifications- LVDS Outputs

Parameter	Description	Conditions	Min.	Typ.	Max.	Units
V <sub>OH</sub>	Output High voltage			1.433		V
V <sub>OL</sub>	Output Low voltage			1.064		V
V <sub>ocm</sub>	Output commode voltage			1.25		V
DV <sub>ocm</sub>	Change in V <sub>ocm</sub> between completely output states				50	mV
R <sub>o</sub>	Output impedance		85		140	Ω

### DC Electrical Specifications – HCSL Outputs

Parameter	Description	Conditions	Min.	Typ.	Max.	Units
V <sub>OH</sub>	Output High voltage		520		900	mV
V <sub>OL</sub>	Output Low voltage		0		150	mV

**DC Electrical Specifications – LVCMOS Output**

Parameter	Description	Conditions	Min.	Typ.	Max.	Units
V <sub>OH</sub>	Output High voltage	V <sub>DD</sub> =3.3V +/-5%, I <sub>OH</sub> = 8mA	2.3			V
		V <sub>DD</sub> =2.5V +/- 5%, I <sub>OH</sub> = 8mA	1.5			V
V <sub>OL</sub>	Output Low voltage	V <sub>DD</sub> =3.3V +/-5%, I <sub>OL</sub> = -8mA			0.5	V
		V <sub>DD</sub> =2.5V +/- 5%, I <sub>OL</sub> = -8mA			0.4	V

**AC Electrical Specifications – Differential Outputs**

Parameter	Description	Conditions	Min.	Typ.	Max.	Units	
F <sub>OUT</sub>	Clock output frequency	LVPECL, LVDS			1500	MHz	
		HCSL			250		
T <sub>r</sub>	Output rise time	From 20% to 80%	LVPECL	120	150	300	ps
			LVDS	120	150	300	
			HCSL	350		550	
T <sub>f</sub>	Output fall time	From 80% to 20%	LVPECL	120	150	300	ps
			LVDS	120	150	300	
			HCSL	350		550	
T <sub>ODC</sub>	Output duty cycle	Frequency<650MHz	LVPECL, HCSL	48		52	%
			LVDS	47		53	
V <sub>PP</sub>	Output swing Single-ended	LVPECL outputs	400			mV	
		LVDS outputs	250				
		HCSL outputs	520				
T <sub>j</sub>	Buffer additive jitter RMS			0.03		ps	
V <sub>CROSS</sub>	Absolute crossing voltage	HCSL		460		mV	
DV <sub>CROSS</sub>	Total variation of crossing voltage	HCSL			140	mV	
T <sub>SK</sub>	Output Skew	10 outputs devices, outputs in same tank, with same load, at DUT.		40	70	ps	
T <sub>PD</sub>	Propagation Delay			1500		ps	
T <sub>OD</sub>	Valid to HiZ				200	ns	
T <sub>OE</sub>	HiZ to valid				200	ns	
T <sub>P2P Skew</sub>	Part to Part Skew <sup>1</sup>			200		ps	

**Notes:**

1. This parameter is guaranteed by design

### AC Electrical Specifications – CMOS

Parameter	Description	Conditions	Min.	Typ.	Max.	Units
F <sub>OUT</sub>	Ref_Out frequency	XTAL input	10		50	MHz
		Reference input			200	MHz
T <sub>j</sub>	Buffer additive jitter RMS	XTAL input		0.3		ps
		Reference input		0.03		ps
t <sub>r</sub> /t <sub>f</sub>	Rise time, Fall time	C <sub>L</sub> = 10pF		1.5		ns
T <sub>ODC</sub>	Output duty cycle	C <sub>L</sub> = 10pF	45		55	%
t <sub>PD</sub>	Propagation delay		100		1500	ps
t <sub>s</sub>	Setup time		300			ps
t <sub>SOD</sub>	Clock edge to output disable	Ref_Out	2		4	cycles
t <sub>SOE</sub>	Clock edge to output enable	Ref_Out	2		4	cycles

### Crystal Characteristics

Parameter	Min.	Typ.	Max.	Units
Mode of Oscillation	Fundamental			
Frequency Range	10		50	MHz
Equivalent Series Resistance (ESR)			70	Ω
Shunt Capacitance			7	pF
Load Capacitance	10		18	pF

**Propagation Delay**

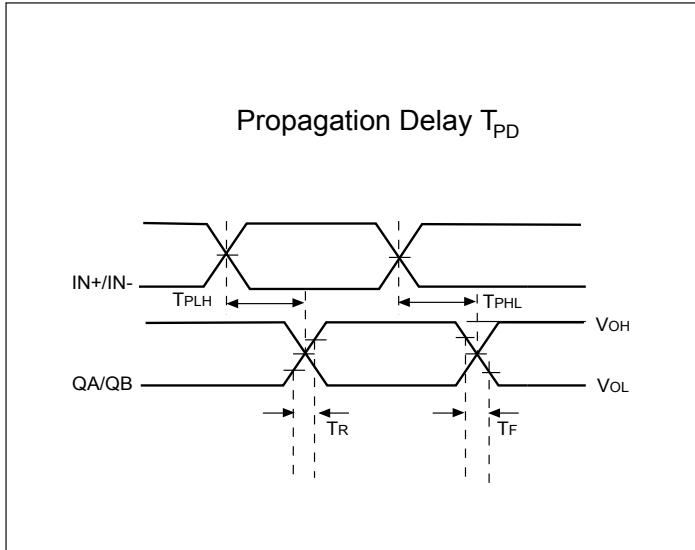

**Output Skew**

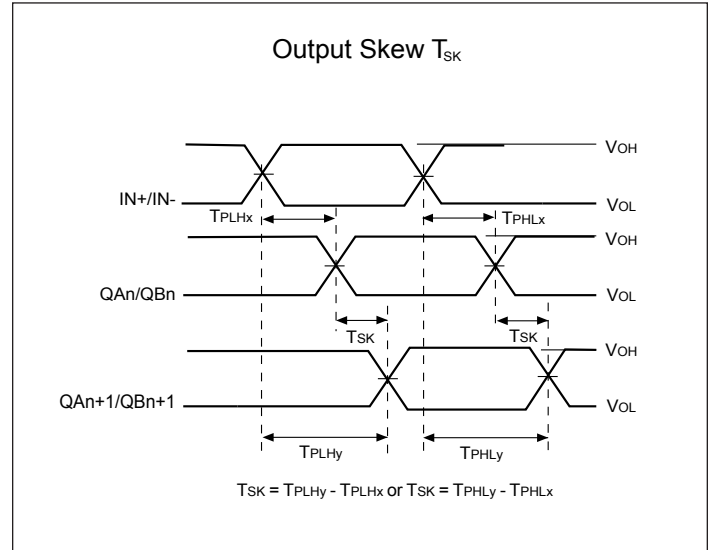

**Part to Part Skew**

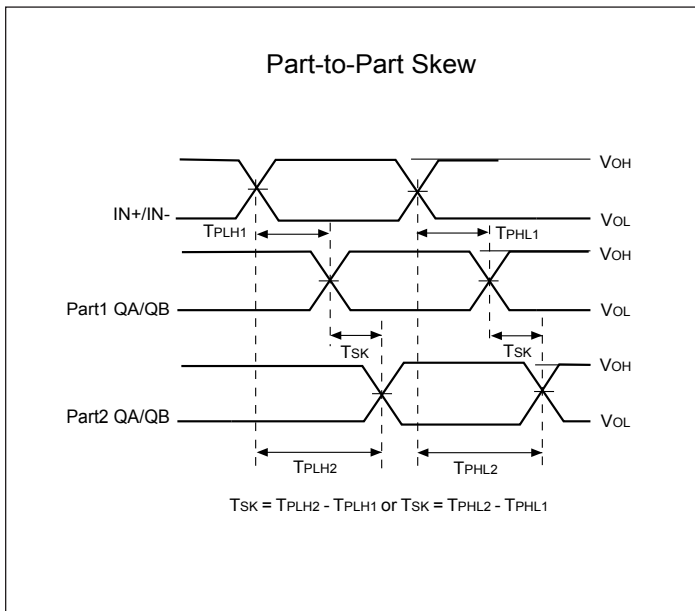

**Configuration Test Load Board Termination for HCSL Outputs**

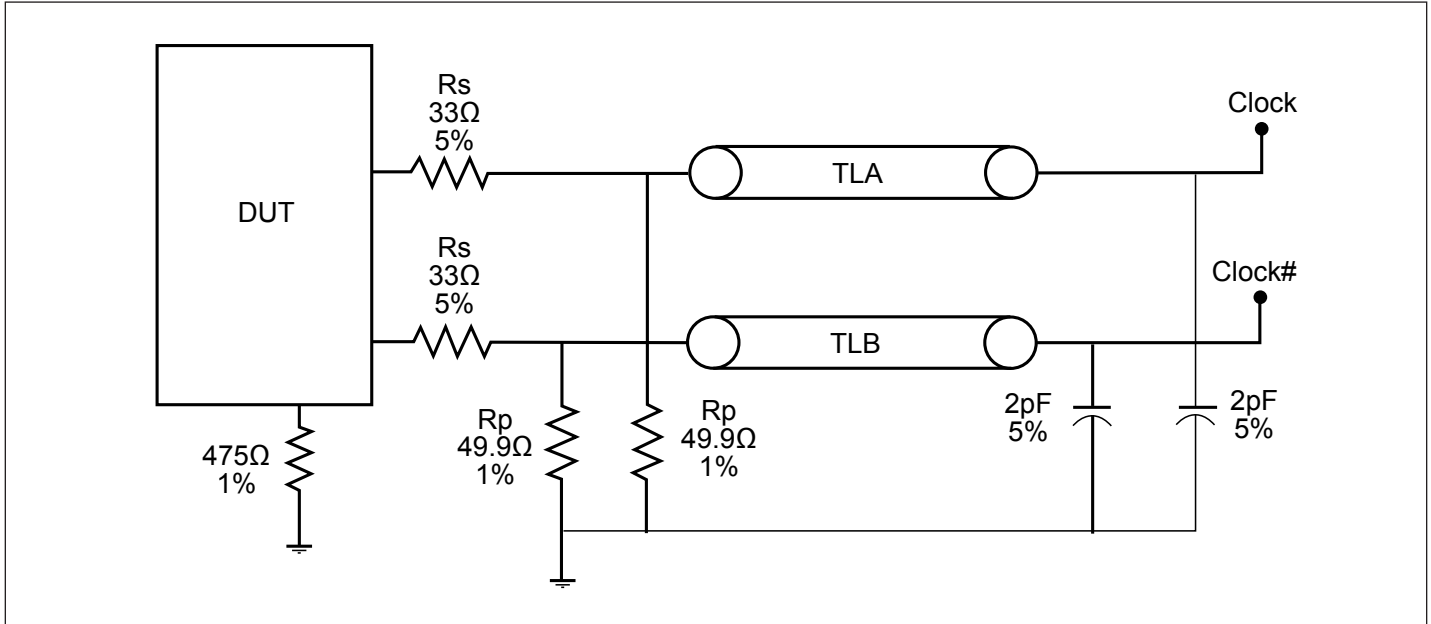

**Configuration Test Load Board Termination for LVPECL/ LVDS Outputs**

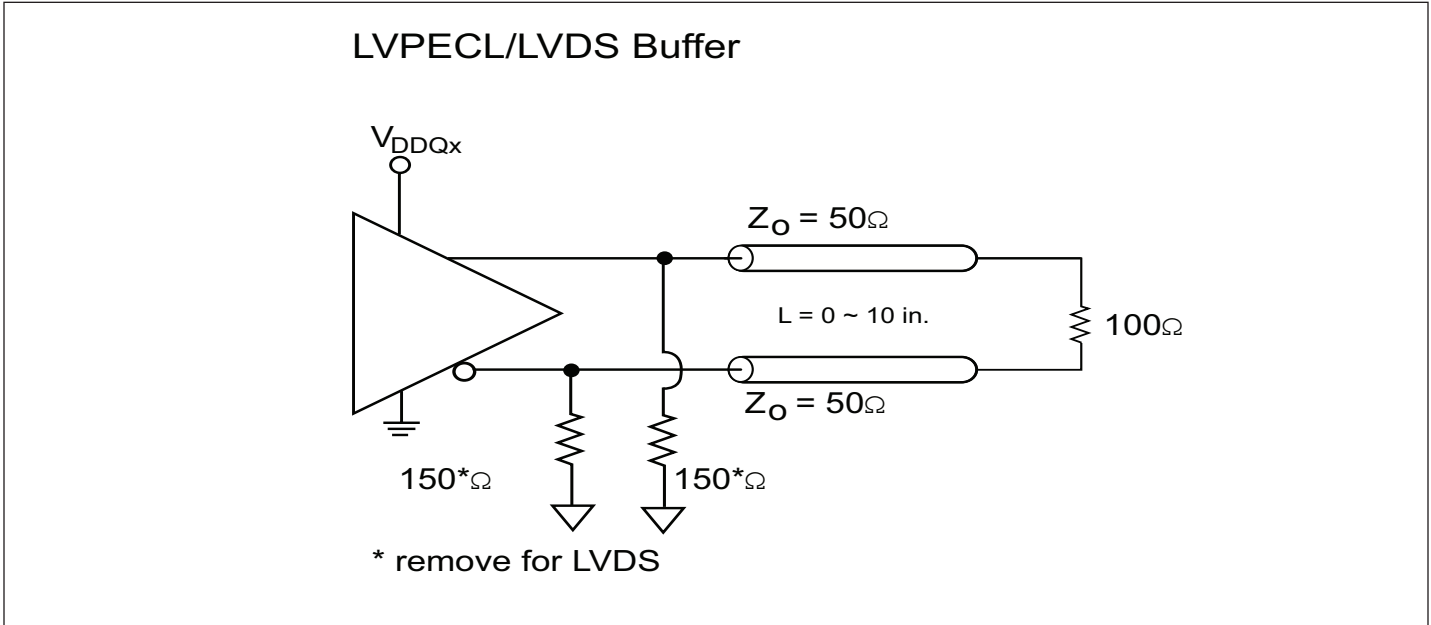

**Configuration Test Load Board Termination for LVCMOS Outputs**

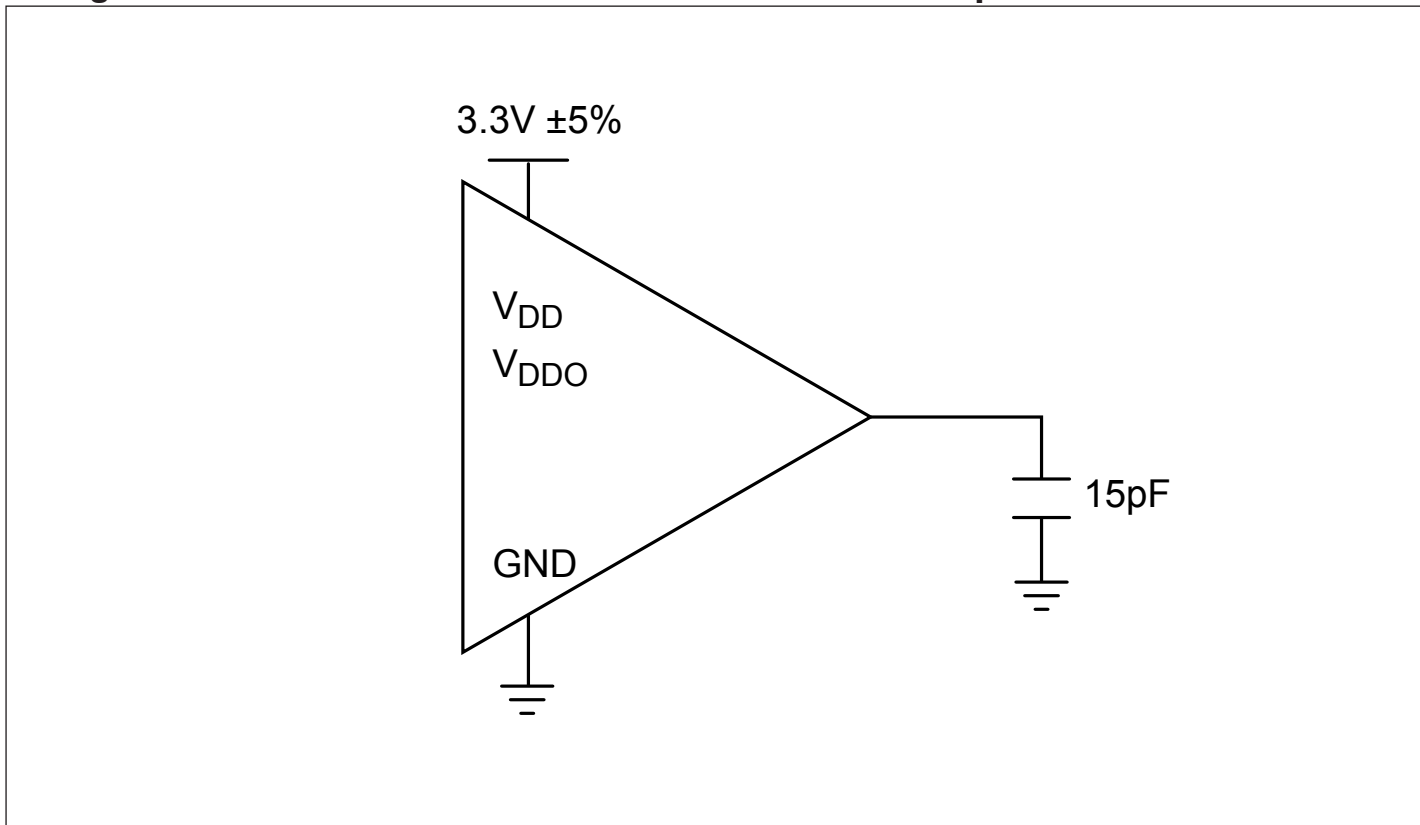

**Packaging Mechanical: 48-Pin TQFN (ZD)**

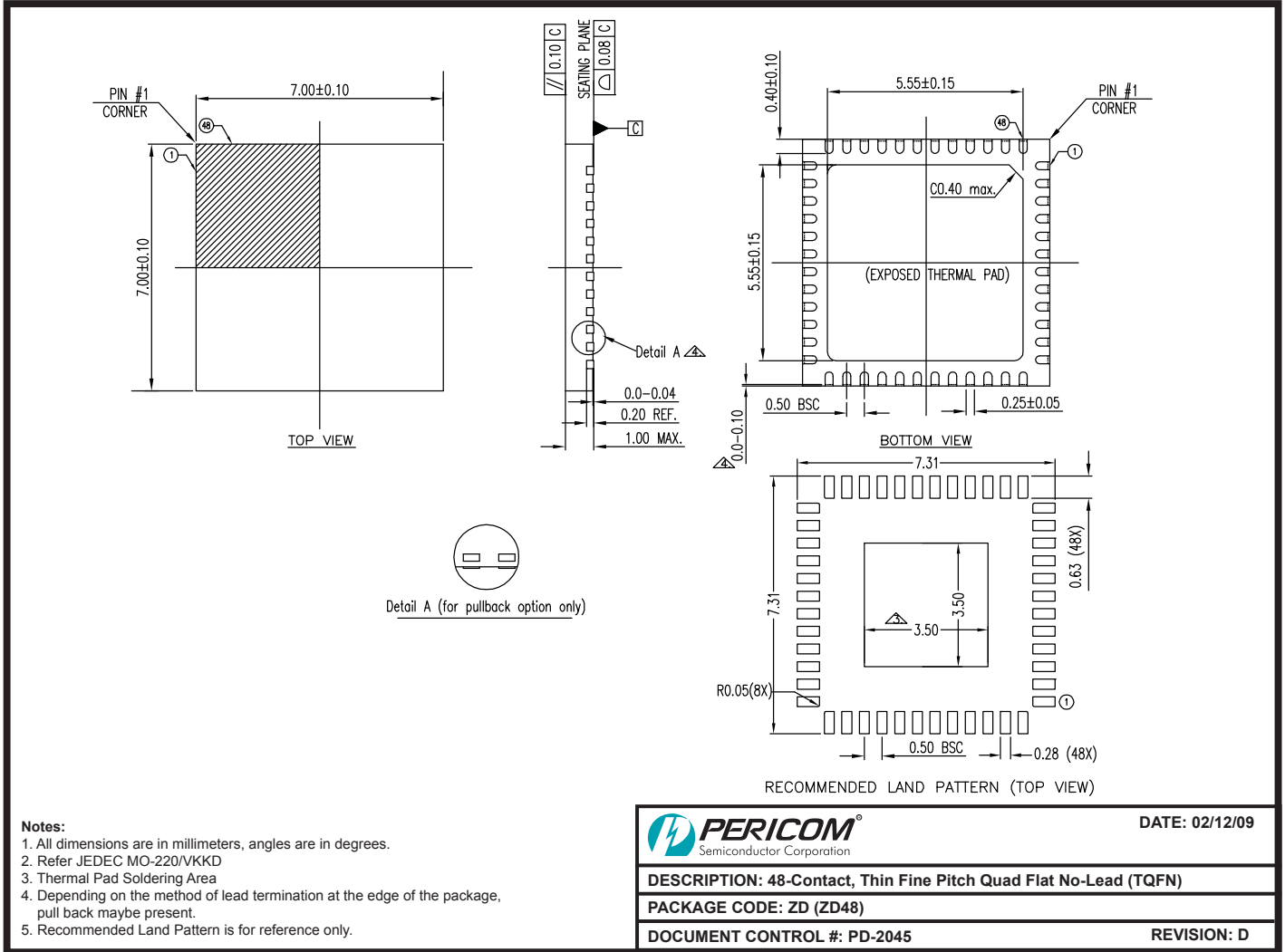

**Ordering Information**

Ordering Code	Package Code	Package Type	Operating Temperature
PI6C49S1510ZDIE	ZD	Pb-free & Green, 48-pin TQFN	-40 °C to 85 °C

**Notes:**

- Thermal characteristics can be found on the company web site at [www.pericom.com/packaging/](http://www.pericom.com/packaging/)
- “E” denotes Pb-free and Green
- Adding an “X” at the end of the ordering code denotes tape and Reel packaging