

Low-Noise Phase-Locked Loop Clock Driver with 9 Clock Outputs

Features

- Operating Frequency up to 150 MHz
- Low-Noise Phase-Locked Loop Clock Distribution to meet 133 MHz Registered DIMM Synchronous DRAM module specifications for server/workstation/PC applications
- Allows Clock Input to have Spread Spectrum modulation for EMI reduction
- Zero input-to-output delay: Distribute One Clock Input to one bank of five and one bank of four outputs, with separate output enables
- Low jitter: cycle-to-cycle jitter ± 75 ps max.
- 30-ohm on-chip series damping resistor at clock output drivers for low noise and EMI reduction
- Operates at 3.3V V_{CC}
- Package (Pb-free and Green available):
- 24-pin TSSOP (L)

Description

The PI6C2509-133 is a “quiet,” low-skew, low-jitter, phase-locked loop (PLL) clock driver, distributing low-noise clock signals for SDRAM and server applications. By connecting the feedback FB_OUT output to the feedback FB_IN input, the propagation delay from the CLK_IN input to any clock output will be nearly zero. This zero-delay feature allows the CLK_IN input clock to be distributed, providing 5 clocks for the first bank, and an additional 4 clocks for the second bank.

This clock driver is designed to meet the PC133 SDRAM Registered DIMM specification. For test purposes, the PLL can be bypassed by strapping AV_{CC} to ground.

Logic Block Diagram

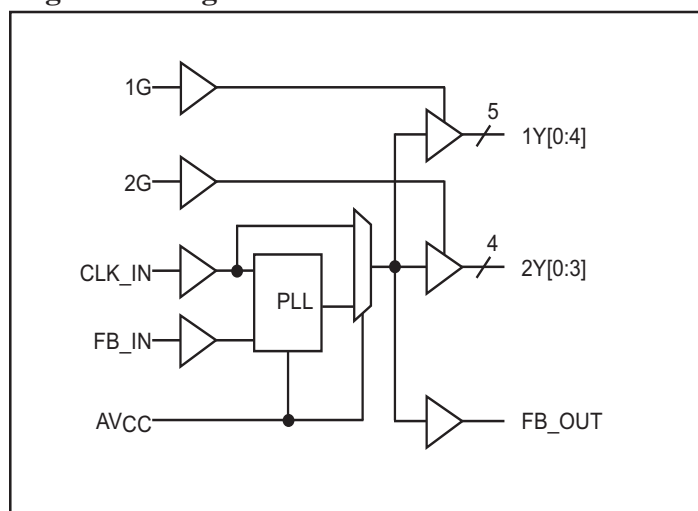

Product Pin Configuration

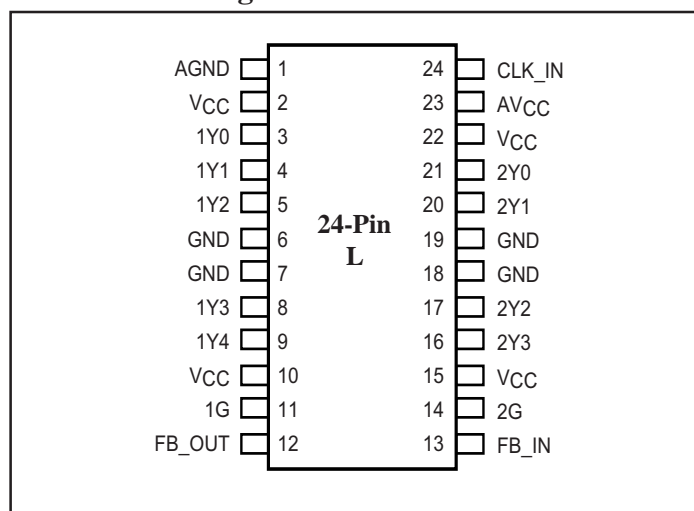

Functional Table

Input Control	Outputs	
$X^{(1)}G$	$X^{(1)}Y[0:3]$	FB_OUT
L	L	CLK_IN
H	CLK_IN	CLK_IN

Note:

1. X is either 1 or 2

Pin Functions

Pin Name	Pin No.	Type	Description
CLK_IN	24	I	Clock input. CLK_IN allows spread spectrum.
FB_IN	13	I	Feedback input. FB_IN provides the feedback signal to the internal PLL.
1G	11	I	Output bank enable. When 1G is LOW, outputs 1Y[0:4] are disabled to a logic low state. When 1G is HIGH, all outputs 1Y[0:4] are enabled.
2G	14	I	Output bank enable. When 2G is LOW, outputs 2Y[0:3] are disabled to a logic low state. When 2G is HIGH, all outputs 2Y[0:3] are enabled.
FB_OUT	12	O	Feedback output. FB_OUT is dedicated for external feedback. FB_OUT has an embedded series-damping resistor of the same value as the clock outputs 1Y _x , 2Y _x .
1Y[0:4]	3,4,5,8,9	O	Clock outputs. These outputs provide low-skew copies of CLK_IN. Each output has an embedded series-damping resistor.
2Y[3:0]	16,17, 20, 21	O	Clock outputs. These outputs provide low-skew copies of CLK_IN. Each output has an embedded series-damping resistor.
AV _{CC}	23	Power	Analog power supply. AV _{CC} can be also used to bypass the PLL for test purposes. When AV _{CC} is strapped to ground, PLL is bypassed and CLK_IN. is buffered directly to the device outputs.
AGND	1	Ground	Analog ground. AGND provides the ground reference for the analog circuitry.
V _{CC}	2,10,15,22	Power	Power supply.
GND	6,7,18,19	Ground	Ground.

DC Specifications (Absolute maximum ratings over operating free-air temperature range)

Symbol	Parameter	Min.	Max.	Units
V_I	Input voltage range	-0.5	$V_{CC} + 0.5$	V
V_O	Output voltage range			
V_{L_DC}	DC input voltage		+5.0	
I_{O_DC}	DC output current		100	mA
Power	Maximum power dissipation at $T_A = 55^\circ\text{C}$ in still air		1.0	W
T_{STG}	Storage temperature	-65	150	$^\circ\text{C}$

Note:

Stress beyond those listed under “absolute maximum ratings” may cause permanent damage to the device.

Parameter	Test Conditions	V_{CC}	Min.	Typ.	Max.	Units
I_{CC}	$V_I = V_{CC}$ or GND; $I_O = 0^{(1)}$	3.6V			10	μA
C_I	$V_I = V_{CC}$ or GND	3.3V		4		pF
C_O	$V_O = V_{CC}$ or GND			6		

Note:

1. Continuous output current

Recommended Operating Conditions

Symbol	Parameter	Min.	Max.	Units
V_{CC}	Supply voltage (Commercial)	3.0	3.6	V
	Supply voltage (Industrial)	3.135	3.465	
V_{IH}	High level input voltage	2.0		
V_{IL}	Low level input voltage		0.8	
V_I	Input voltage	0.0	V_{CC}	
T_A	Operating free-air temperature (Commercial)	0	70	$^\circ\text{C}$
	Operating free-air temperature (Industrial)	-40	85	

Electrical Characteristics (Over recommended operating free-air temperature range)

Pull Up/Down Currents: $V_{CC} = 3.0\text{V}$ ($V_{CC} = 3.135\text{V}$)

Symbol	Parameter	Condition	Min.	Max.	Units
I_{OH}	Pull-up current	$V_{OUT} = 2.4\text{V}$		-13.6	mA
	Pull-up current	$V_{OUT} = 2.0\text{V}$		-22	
I_{OL}	Pull-down current	$V_{OUT} = 0.8\text{V}$	19		
	Pull-down current	$V_{OUT} = 0.55\text{V}$	13		

AC Specifications

(Timing requirements over recommended ranges of supply voltage and operating free-air temperature.)

Symbol	Parameter	Min.	Max.	Units
F _{CLK}	Input clock frequency (Commercial)	25	150	MHz
	Input clock frequency (Industrial)	25	125	
	Input clock duty cycle	40	60	%
	Stabilization time after power up		1	ms

Switching Characteristics

(Over recommended ranges of supply voltage and commercial temperature, V_{CC}=3.3V ±0.3V, T_A=0~70°C, C_L=15pF)

Parameter	Test Conditions	Min.	Typ.	Max.	Units
t _{pe} , Phase error	CLK_IN to FB_IN, f = 133 MHz	-150		150	ps
t _j , Jitter (cycle-to-cycle)	f = 133 MHz	-75		75	
t _{sk} , Output skew	Yn or FB_OUT to Yn or FB_OUT			150	
t _{dc} , Duty cycle	f = 133 MHz, V _{CC} /2	45	50	55	%
t _r , Rise time	V _O = 0.4V to 2V		1.0		ns
t _f , Fall time	V _O = 2V to 0.4V		1.1		

Switching characteristics

(Over recommended ranges of supply voltage and industrial temperature, V_{CC}=3.3V ±0.165V, T_A=-40~85°C, C_L=15pF)

Parameter	Test Conditions	Min.	Typ.	Max.	Units
t _{pe} , Phase error	CLK_IN to FB_IN, f = 125 MHz	-150		150	ps
t _j , Jitter (cycle-to-cycle)	f = 125 MHz	-75		75	
t _{sk} , Output skew	Yn or FB_OUT to Yn or FB_OUT			150	
t _{dc} , Duty cycle	f = 125 MHz, V _{CC} /2	45	50	55	%
t _r , Rise time	V _O = 0.4V to 2V		1.0		ns
t _f , Fall time	V _O = 2V to 0.4V		1.1		

Note: These switching parameters are guaranteed, but not production tested.

Packaging Mechanical: 24-pin Plastic Thin Shrink Small-Outline (L)

	<p>DOCUMENT CONTROL NO. PD - 1312</p> <hr/> <p>REVISION: E DATE: 03/09/05</p>
--	--

<p>Note:</p> <ol style="list-style-type: none"> 1. Package Outline Exclusive of Mold Flash and Metal Burr 2. Controlling dimensions in millimeters 3. Ref: JEDEC MO-153F/AD 	 <p>Pericom Semiconductor Corporation 3545 N. 1st Street, San Jose, CA 95134 1-800-435-2335 • www.pericom.com</p> <hr/> <p>DESCRIPTION: 24-Pin, 173-Mil Wide, TSSOP</p> <hr/> <p>PACKAGE CODE: L</p>
---	---

Note:

- For latest package info, please check: <http://www.pericom.com/products/packaging/mechanicals.php>

Ordering Information

Ordering Code	Packaging Code	Package Types
PI6C2509-133LEX	L	Pb-free and Green, 24-pin, 173 mil TSSOP

Notes:

- Thermal characteristics can be found on the company web site at www.pericom.com/packaging/
- E = Pb-free and Green
- Adding an X suffix = Tape/Reel