

Features

- Maximum rated frequency: 133 MHz
- Low cycle-to-cycle jitter
- Input to output delay, less than 200ps
- Internal feedback allows outputs to be synchronized to the clock input
- Operates at 3.3V V_{DD}
- Space-saving Package: (Pb-free & Green available)
 - 16-Pin TSSOP (L)
 - 16-Pin SOIC (W)

Description

The PI6C2409-1 is a PLL based, zero-delay buffer, with the ability to distribute nine outputs of up to 133 MHz at 3.3V. All the outputs are distributed from a single clock input CLKIN and output OUT0 performs zero delay by connecting a feedback to PLL.

PI6C2409-1 has two banks of four outputs that can be controlled by the selection inputs, SEL1 & SEL2. It also has a power sparing feature: when input SEL1 is 0 and SEL2 is 1, PLL is turned off and all outputs are referenced from CLKIN. PI6C2409-1 is available in high drive and industrial environment versions.

An internal feedback on OUT0 is used to synchronize the outputs to the input; the relationship between loading of this signal and the outputs determines the input-output delay. PI6C2409-1 are characterized for both commercial and industrial operation

Block Diagram

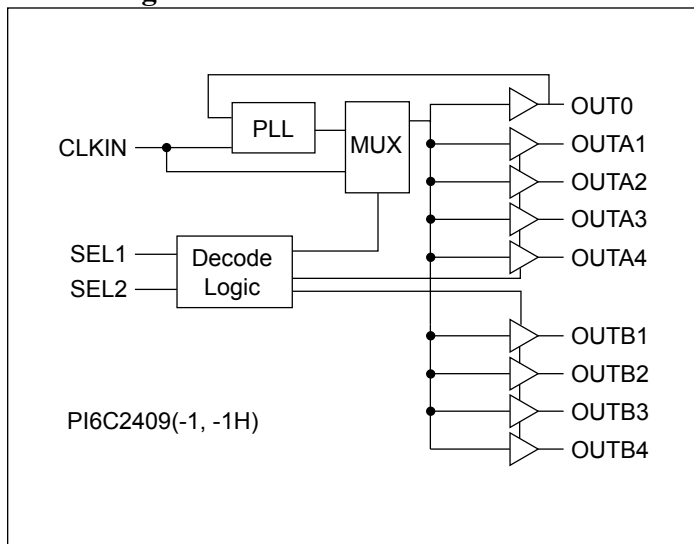

Pin Configuration

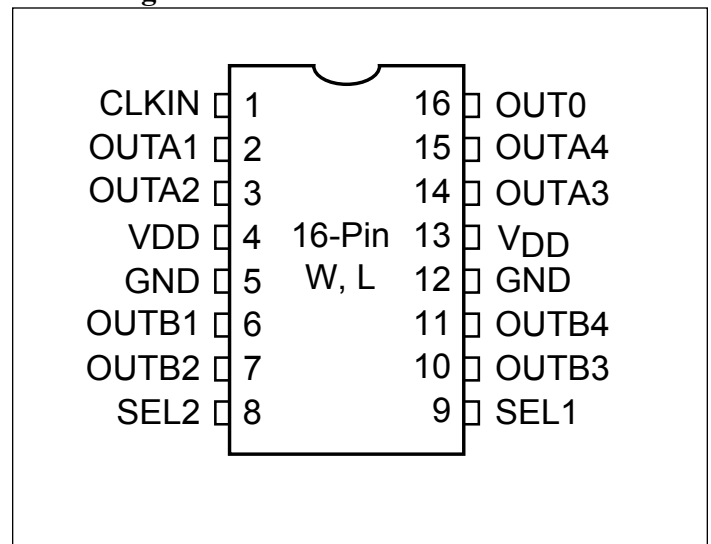

Input Select Decoding

SEL2	SEL1	OUTA [1-4]	OUTB [1-4]	Output Source (OUT0)	PLL
0	0	3-State	3-State	PLL	ON
0	1	PLL	3-State	PLL	ON
1	0	CLKIN	CLKIN	CLKIN	OFF
1	1	PLL	PLL	PLL	ON

Pin Description

Pin	Signal	Description
1	CLKIN	Input clock reference frequency (weak pull-down)
2, 3, 14, 15	OUTA[1-4]	Clock outputs, Bank A
4, 13	VDD	3.3V supply
5, 12	GND	Ground
6, 7, 10, 11	OUTB[1-4]	Clock outputs, Bank B
8	SEL2	Select input, bit 2 (weak pull-up)
9	SEL1	Select input, bit 1 (weak pull-up)
16	OUT0	Clock Output , internal PLL feedback

Zero-Delay and Skew Control

CLKIN Input to OUTx Delay vs. Difference in Loading between OUT0 pin and OUTx pins

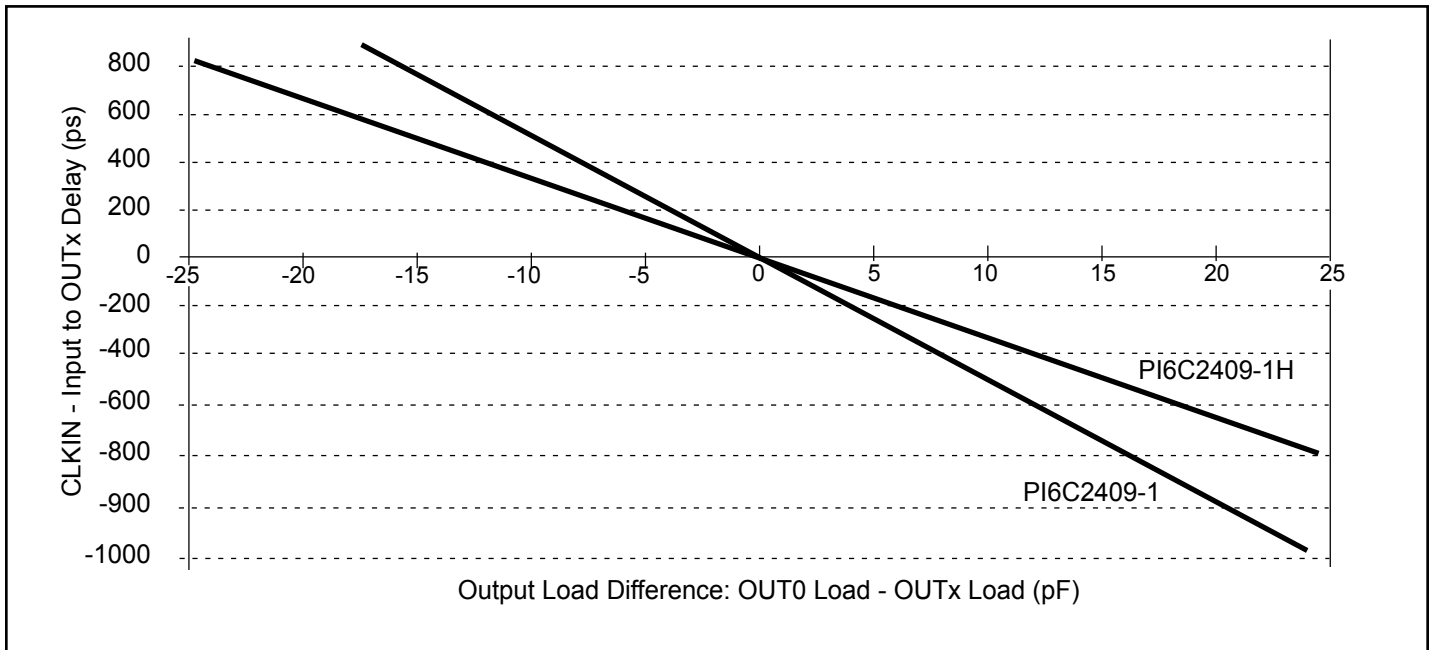

The relationship between loading of the OUT0 signal and other outputs determines the input-output delay. Zero delay is achieved when all outputs, including feedback, are loaded equally.

Maximum Ratings

Supply Voltage to Ground Potential.....	-0.5V to +7.0V
DC Input Voltage (Except CLKIN).....	-0.5V to V _{DD} +0.5V
DC Input Voltage CLKIN	-0.5 to 7V
Storage Temperature	-65°C to +150°C
Maximum Soldering Temperature (10 seconds)	260°C
Junction Temperature	150°C
Static Discharge Voltage (per MIL-STD-883, Method 3015).....	>2000V

Operating Conditions (V_{CC} = 3.3V ±0.3V)

Parameter	Description	Min.	Max.	Units
V _{DD}	Supply Voltage	3.0	3.6	V
T _A	Commercial Operating Temperature	0	70	°C
	Industrial Operating Temperature	-40	85	
C _L	Load Capacitance, below 100 MHz		30	pF
	Load Capacitance, from 100 MHz to 133 MHz	-	15	
C _{IN}	Input Capacitance	-	7	

DC Electrical Characteristics for Industrial Temperature Devices

Parameters	Description	Test Conditions	Min.	Max.	Units
V _{IL}	Input LOW Voltage			0.8	V
V _{IH}	Input HIGH Voltage		2.0		
I _{IL}	Input LOW Current	V _{IN} = 0V		50.0	μA
I _{IH}	Input HIGH Current	V _{IN} = V _{DD}		125	
V _{OL}	Output LOW Voltage	I _{OL} = 8mA (-1); I _{OL} = 12mA (-1H)		0.4	V
V _{OH}	Output HIGH Voltage	I _{OH} = -8mA (-1); I _{OH} = -12mA (-1H)	2.4		
I _{DD}	Bypass, PLL OFF	SEL1 = 0, SEL2 = 1		1.0	mA
	Supply Current	Unloaded outputs 100 MHz, Select inputs at V _{DD} or GND		54.0	
		Unloaded outputs 66 MHz, CLKIN		39.0	

AC Electrical Characteristics for Industrial Temperature Devices

Parameters	Name	Test Conditions	Min.	Typ.	Max.	Units
F _O	Output Frequency	30pF load (-1, -1H)	10.0		100	MHz
		10pF load, (-1, -1H)			133	
t _{DC}	Duty Cycle ⁽¹⁾ (-1, -1H)	Measured at V _{DD} /2, F _{OUT} = 66.67 MHz	40.0	50	60.0	%
	Duty Cycle ⁽¹⁾ (-1H)	Measured at V _{DD} /2V, F _{OUT} < 50MHz	45.0		55.0	
t _R	Rise Time ⁽¹⁾ (-1)	Measured between 0.8V and 2.0V			2.5	ns
	Rise Time ⁽¹⁾ (-1H)	Measured between 0.8V and 2.0V			1.5	
t _F	Fall Time ⁽¹⁾ (-1)	Measured between 0.8V and 2.0V			2.5	
	Fall Time ⁽¹⁾ (-1H)	Measured between 0.8V and 2.0V			1.5	
t _{SK(O)}	Output to Output Skew (-1, -1H) ⁽¹⁾	All outputs equally loaded			250	ps
t ₀	Delay, CLKIN Rising Edge to OUT0 Rising Edge ⁽¹⁾ (-1, -1H)	Measured at V _{DD} /2		0	±350	
t _{SK(D)}	Device-to-Device Skew ⁽¹⁾ (-1, -1H)	Measured at V _{DD} /2 on OUT0 pins of devices		0	700	
t _{SLEW}	Output Slew Rate ⁽¹⁾ (-1, -1H)	Measured between 0.8V & 2.0V on -1H device using Test Crt #2	1			V/ns
t _{JIT}	Cycle-to-Cycle Jitter ⁽¹⁾ (-1, -1H)	Measured at 66.67 MHz, loaded 30pF load			200	ps
t _{LOCK}	PLL Lock Time ⁽¹⁾ (-1, -1H)	Stable power supply, valid clocks presented on CLKIN pin			1.0	ms

Note:

1. See Switching Waveforms on page 6.

DC Electrical Characteristics for Commercial Temperature Devices

Parameters	Description	Test Conditions	Min.	Max.	Units
V _{IL}	Input LOW Voltage	-	-	0.8	V
V _{IH}	Input HIGH Voltage	-	2.0	-	
I _{IL}	Input LOW Current	V _{IN} = 0V	-	50	μA
I _{IH}	Input HIGH Current	V _{IN} = V _{DD}	-	125	
V _{OL}	Output LOW Voltage	I _{OL} = 8mA (-1); I _{OL} = 12mA (-1H)	-	0.4	V
V _{OH}	Output HIGH Voltage	I _{OH} = -8mA (-1); I _{OH} = -12mA (-1H)	2.4	-	
I _{DD}	Bypass, PLL off	SEL1 = 0 SEL2 = 1	-	1.0	mA
	Supply Current	Unloaded outputs, 66.67 MHz, Select inputs at V _{DD} or GND	-	39	
		Unloaded outputs 100 MHz Select Inputs @ V _{DD} or GND	-	54	

AC Electrical Characteristics for Commercial Temperature Devices

Parameters	Name	Test Conditions	Min.	Typ.	Max.	Units
F _O	Output Frequency	30pF load (-1, -1H)	10.0		100	MHz
		10pF load, (-1, -1H)			133	
t _{DC}	Duty Cycle ⁽¹⁾ (-1, -1H)	Measured at V _{DD} /2, F _O = 66.67 MHz	40.0	50	60.0	%
	Duty Cycle ⁽¹⁾ (-1H)	Measured at V _{DD} /2V, F _O < 50 MHz	45.0		55.0	
t _R	Rise Time ⁽¹⁾ (-1)	Measured between 0.8V and 2.0V			2.5	ns
	Rise Time ⁽¹⁾ (-1H)				1.5	
t _F	Fall Time ⁽¹⁾ (-1)				2.5	
	Fall Time ⁽¹⁾ (-1H)				1.5	
t _{SK(O)}	Output to Output Skew (-1,-1H) ⁽¹⁾	All outputs equally loaded			250	ps
t ₀	Delay, CLKIN Rising Edge to OUT0 Rising Edge ⁽¹⁾ (-1, -1H)	Measured at V _{DD} /2		0	±350	
t _{SK(D)}	Device-to-Device Skew ⁽¹⁾ (-1, -1H)	Measured at V _{DD} /2 on OUT0 pins of devices		0	700	
t _{SLEW}	Output Slew Rate ⁽¹⁾ (-1, -1H)	Measured between 0.8V & 2.0V on -1H device using Test Crt #2	1			V/ns
t _{JIT}	Cycle-to-Cycle Jitter ⁽¹⁾ (-1,-1H)	Measured at 66.67 MHz, loaded 30pF load			200	ps
t _{LOCK}	PLL Lock Time ⁽¹⁾ (-1, -1H)	Stable power supply, valid clocks presented on CLKIN pin			1.0	ms

Note:

1. See Switching Waveforms on page 6.

Switching Waveforms

Duty Cycle Timing

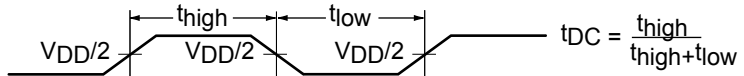

All Outputs Rise/Fall Time

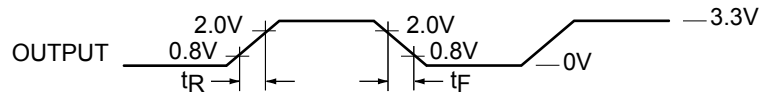

Output-Output Skew

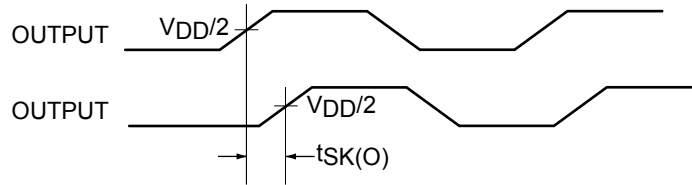

Device-Device Skew

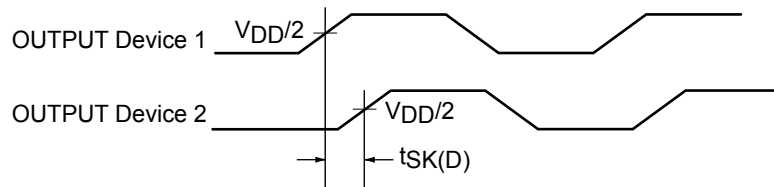

Input-Output Propagation Delay

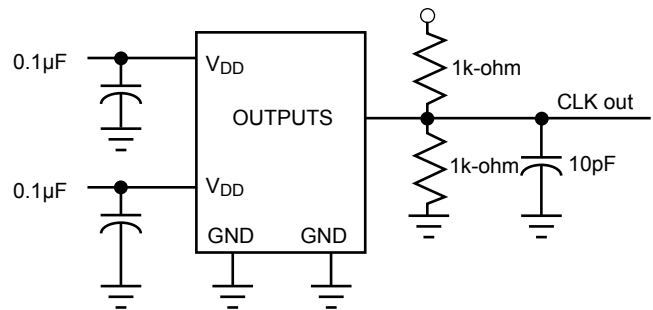
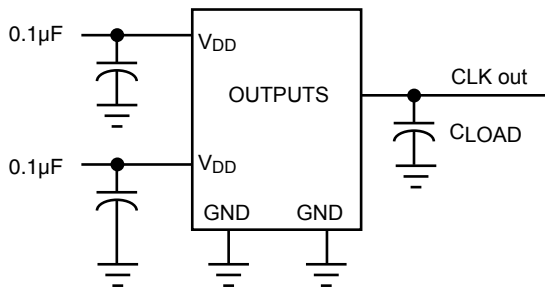
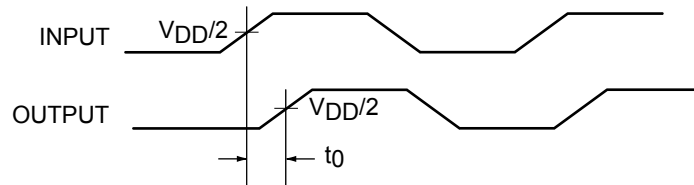

Packaging Mechanical: 16-Pin TSSOP (L)

DOCUMENT CONTROL NO. PD - 1310
REVISION: E DATE: 03/09/05

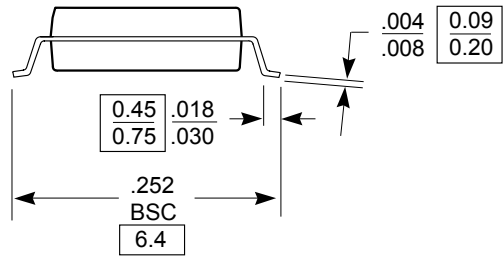
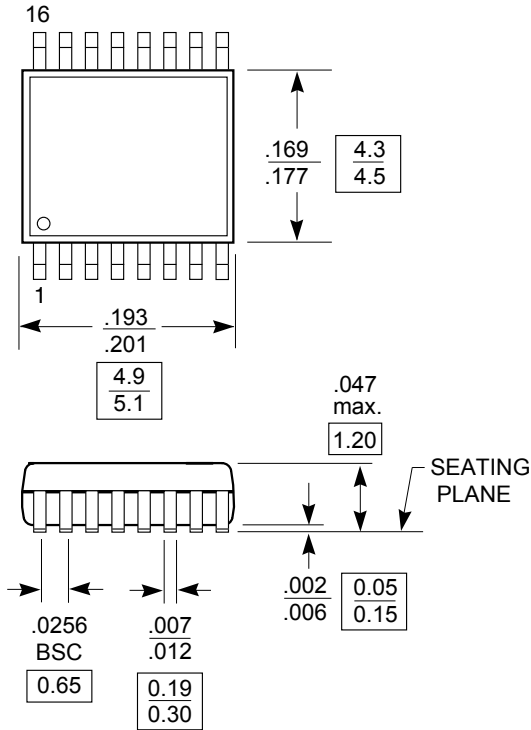

Note:

1. Package Outline Exclusive of Mold Flash and Metal Burr
2. Controlling dimensions in millimeters
3. Ref: JEDEC MO-153F/AB



Pericom Semiconductor Corporation
 3545 N. 1st Street, San Jose, CA 95134
 1-800-435-2335 • www.pericom.com

DESCRIPTION: 16-Pin, 173-Mil Wide, TSSOP

PACKAGE CODE: L

Packaging Mechanical: 16-Pin SOIC (W)

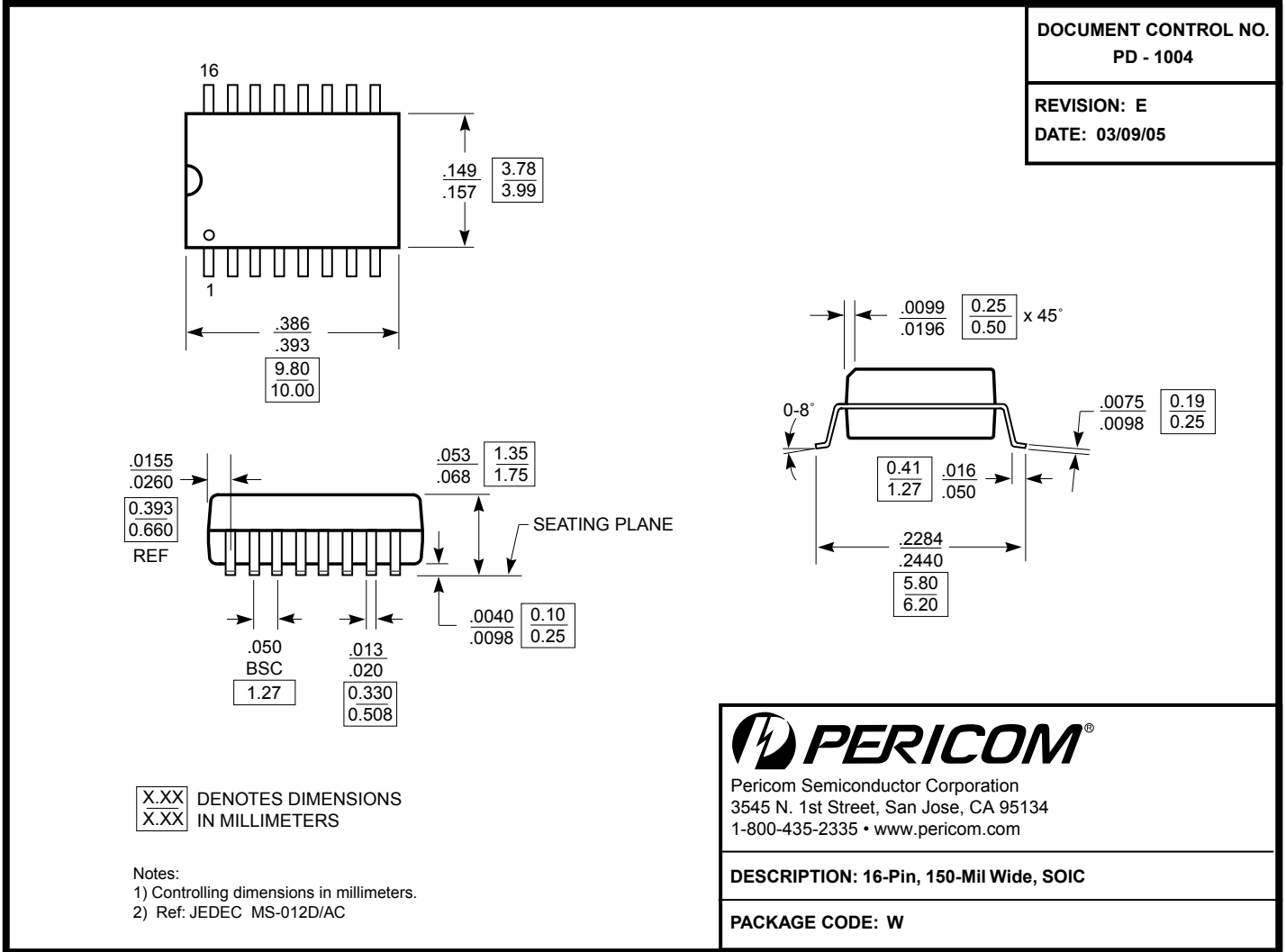

Note:
Controlling dimensions in millimeters. Ref: JEDEC MS - 012 AC

Ordering Information

Ordering Code	Package Code	Package Description	Operating Range
PI6C2409-1HLE	L	Pb-free and Green, 16-pin 173-mil TSSOP	Commercial
PI6C2409-1HWE	W	Pb-free and Green, 16-pin 150-mil SOIC	Commercial
PI6C2409-1HWIE	W	Pb-free and Green, 16-pin 150-mil SOIC	Industrial

Notes:
Thermal characteristics can be found on the company web site at www.pericom.com/packaging/
E = Pb-free and Green
Adding an X suffix = Tape/Reel