

2.5/3.3V 220 MHz High-Speed, Low-Jitter, Low Skew, Zero-Delay Clock Buffer with 10 Outputs

Features

- Phase-Lock Loop Clock Distribution (Zero Input-to-Output Delay)
- Distributes one to one bank of TEN outputs
- High-Performance
 - 10MHz to 220MHz operation frequency range
 - <100ps output-to-output skew
- Spread-spectrum capable
- Output Enable
- Power supply
 - +2.5V $\pm 5\%$
 - +3.3V $\pm 10\%$
- Temperature range
 - -40°C to +85°C Industrial temp range
- Packaging: (Pb-free & Green)
 - 24-pin TSSOP (L)

Description

The PI6C22510 is a low jitter, low skew, high-speed Zero-Delay Buffer with 10 outputs designed to address high-speed clock distribution applications.

The PI6C22510 features a patented Phase Lock Loop (PLL) with high drive output capability.

The PI6C22510 operates from a 2.5V $\pm 5\%$ or 3.3V $\pm 10\%$ supply and is guaranteed over the full commercial and industrial temperature range of -40°C to +85°C. All support documentation can be found on Pericom's web site at: www.pericom.com.

Block Diagram

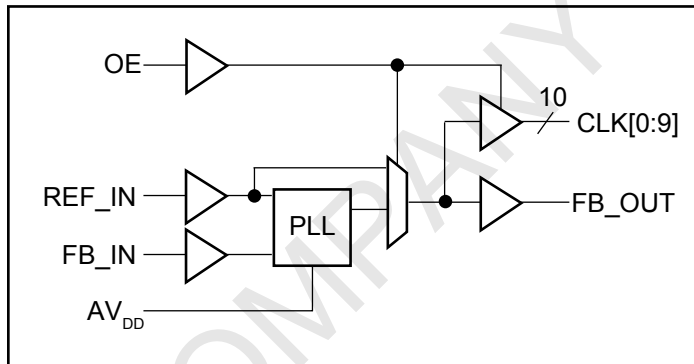

Pin Configuration

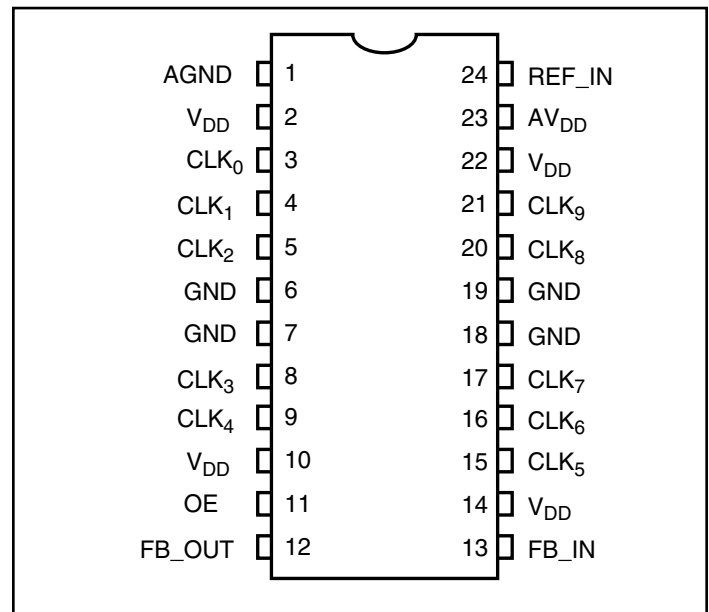

Functional Table

Inputs	Outputs	
OE	CLK[0:9]	FB_OUT
L	L ⁽¹⁾	REF_IN
H	REF_IN	REF_IN

1. 100k-ohm internal pull-down

Pin Description

Pin	Signal	Description
11	OE	Output Enable. When OE is logic HIGH, all outputs are enabled. When OE is LOW, CLK outputs are LOW with 100k-ohm pull-down.
24	REF_IN	Reference clock input with weak pull down
12	FB_OUT	Feedback output. FB_OUT is dedicated for external feedback.
3 4, 5 8, 9 15, 16 17, 20 21	CLK0, CLK1, CLK2, CLK3, CLK4, CLK5, CLK6, CLK7, CLK8, CLK9	Clock Outputs. Clock outputs contain a weak pull-down.
23	AV _{DD}	Analog power supply.
13	FB_IN	Feedback input, FB_IN provides the feedback signal to the internal PLL
6, 7, 18, 19	GND	Ground
2, 10, 14, 22	VDD	Power
1	AGND	Analog Ground

Maximum Ratings⁽¹⁾

Supply Voltage	
VDD	-0.5V to +4.6V
REF_IN	-0.5V to +4.6V
Input Current	-50mA
Output Current	±50mA
Lead Temperature (soldering, 10 sec.)	+260°C
Storage Temperature (Ts)	-65°C to +150°C
Junction Temperature	+150°C
Operating Temperature (industrial)	-40°C to +85°C

Operation Ratings⁽²⁾

Supply Voltage	
VDD	+3.0V to +3.6V
VDD	+2.375V to +2.625V
Ambient Temperature (TA)	-40°C to +85°C
Package Thermal Resistance ⁽²⁾	
θ _{JA}	
Still-Air	84°C/W
θ _{JB}	
Junction-to-Board	13°C

Notes:

- Stresses greater than those listed under Maximum Ratings may cause permanent damage to the device. This is a stress rating only and functional operation of the device at these or any other conditions above those indicated in the operational sections of the this specifications is not implied. Exposure to absolute maximum rating conditions for extended periods may affect reliability.
- θ_{JA} and θ_{JB} values are determined for a 4-layer board in still-air, unless otherwise stated.

**DC Electrical Characteristics**

Parameter	Description	Test Conditions	Min.	Max.	Units
V _{IL}	Input LOW Voltage	V _{DD} = 3.3V		0.8	V
		V _{DD} = 2.5V		0.7	
V _{IH}	Input HIGH Voltage	V _{DD} = 3.3V	2.0		
		V _{DD} = 2.5V	1.7		
I _{IL}	Input LOW Current	V _{IN} = 0V		50	μA
I _{IH}	Input HIGH Current	V _{IN} = V _{DD}		125	
V _{OL}	Output LOW Voltage	I _{OL} = 12mA	V _{DD} = 3.3V	0.3	V
			V _{DD} = 2.5V	0.4	
V _{OH}	Output HIGH Voltage	V _{DD} = 2.5V, I _{OH} = -12mA	1.8		
		V _{DD} = 3.3V, I _{OH} = -12mA	2.4		
I _{DD}	Supply Current	Unloaded outputs 66 MHz	V _{DD} = 3.3V	85	mA
			V _{DD} = 2.5V	55	mA

AC Electrical Characteristics

Parameter	Description	Test Conditions	Min.	Typ.	Max.	Units
F _O	Output Frequency	V _{DD} = 2.5V, C _L = 15pF	10		200	MHz
		V _{DD} = 3.3V, C _L = 15pF	10		220	MHz
BW	Bandwidth for PLL	V _{DD} = 2.5V		0.8		MHz
		V _{DD} = 3.3V		1.5		
t _{IDC}	Input Duty Cycle ⁽¹⁾	Measured at V _{DD} /2	40	50	60	%
t _{DC}	Output Duty Cycle ⁽¹⁾	Measured at V _{DD} /2, C _L =15pF, except no load for FBO _{Out} @ 15pF load	45	50	55	%
t _R	Rise Time ⁽¹⁾	For 3.3V: Measured between 0.8V and 2.0V			1.6	ns
		For 2.5V: Measured between 0.6V and 1.8V			2.1	
t _F	Fall Time ⁽¹⁾	For 3.3V: Measured between 0.8V and 2.0V			1.6	
		For 2.5V: Measured between 0.6V and 1.8V			2.1	
t _{sk(o)}	Output to Output Skew ⁽¹⁾⁽²⁾	All outputs equally loaded	V _{DD} = 3.3V		75	ps
			V _{DD} = 2.5V		100	
t _{SK(D)}	Device-to-device Skew ⁽³⁾	Measured at V _{DD} /2 on CLK _x pins of device	-300	0	+300	
t _{JIT}	Cycle-to-Cycle Jitter	15pF load, >100MHz	V _{DD} = 3.3V		150	
			V _{DD} = 2.5V		200	
t _{PJ}	Period Jitter (Peak)	15pF load, >100MHz	V _{DD} = 3.3V		175	
			V _{DD} = 2.5V		175	
t _{LOCK}	PLL Lock Time ⁽¹⁾	Stable power supply, valid clocks presented on REF_IN pin			1.0	ms

Notes:

1. See Switching Waveforms
2. Output-to-output skew includes CLK0-9.
3. Specifications are guaranteed by design and not production tested.

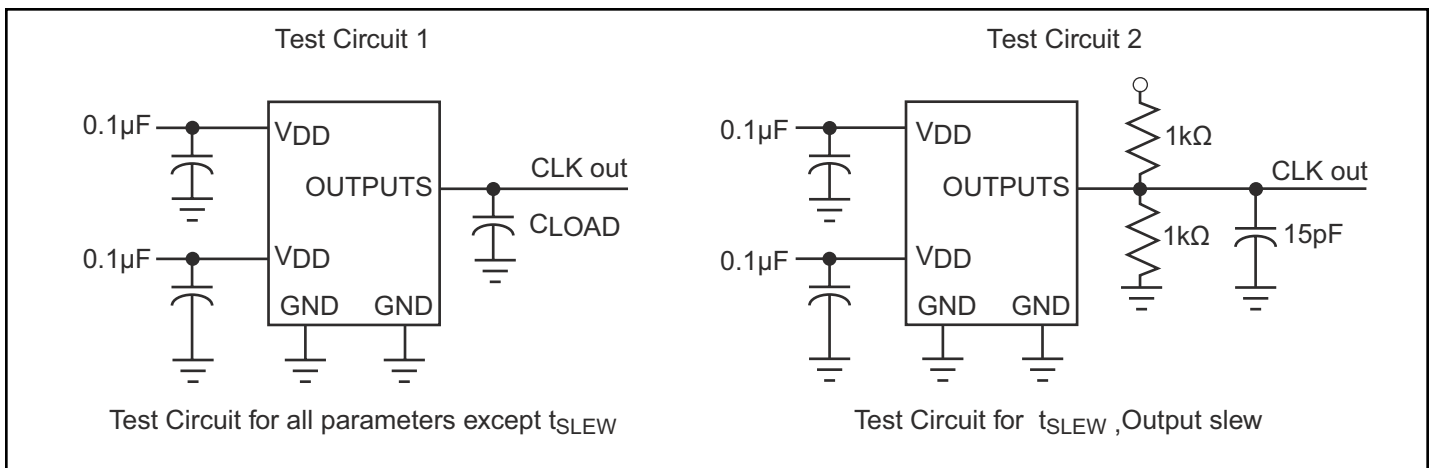
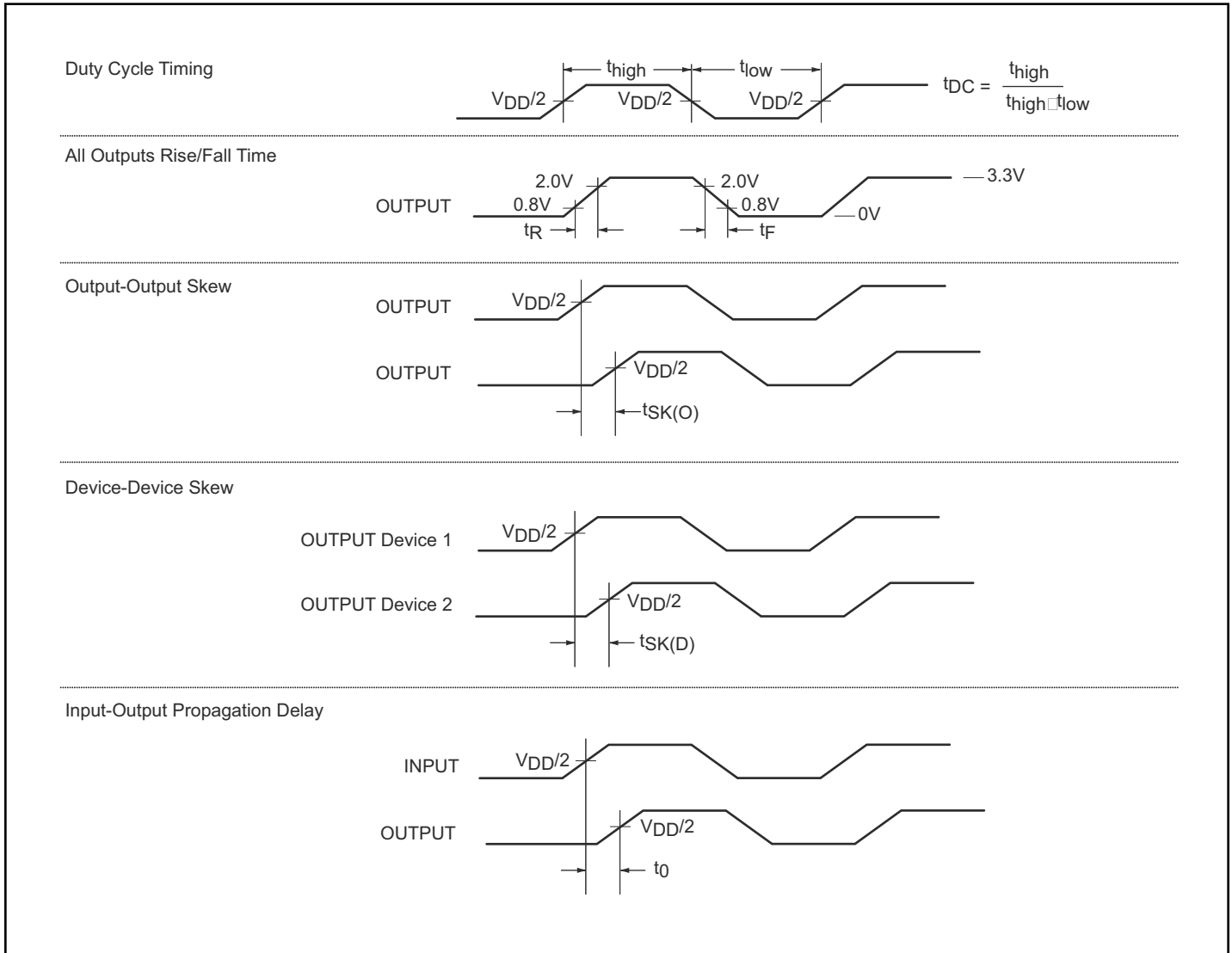
Switching Waveforms

DOCUMENT CONTROL NO.
 PD - 1312

REVISION: E
 DATE: 03/09/05

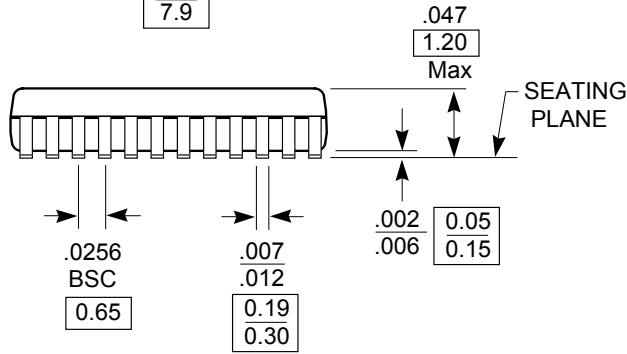
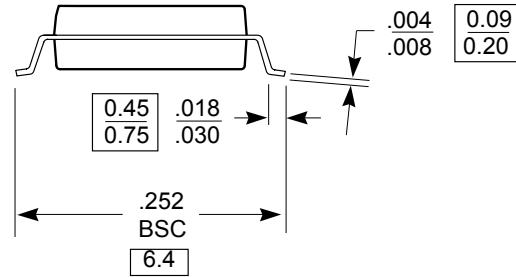
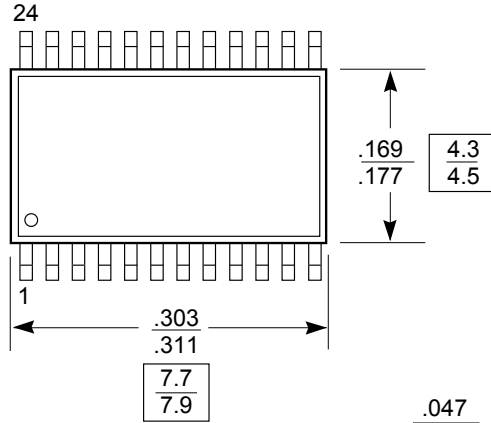

Pericom Semiconductor Corporation
 3545 N. 1st Street, San Jose, CA 95134
 1-800-435-2335 • www.pericom.com

DESCRIPTION: 24-Pin, 173-Mil Wide, TSSOP

PACKAGE CODE: L

Note:

1. Package Outline Exclusive of Mold Flash and Metal Burr
2. Controlling dimensions in millimeters
3. Ref: JEDEC MO-153F/AD

Ordering Information(1,2,3)

Ordering Code	Package Code	Package Description
PI6C22510LE	L	Pb-free & Green, 24-pin TSSOP

Notes:

1. Thermal characteristics can be found on the company web site at www.pericom.com/packaging/
2. E = Pb-free and Green
3. Adding an X suffix = Tape/Reel