

Features

- Phase jitter filter for PCIe 3.0 application
- Eight Pairs of Differential Clocks
- Low skew < 50ps (PI6C20800B), <60ps (PI6C20800BI)
- Low Cycle-to-cycle jitter < 60ps
- Output Enable for all outputs
- Outputs Tristate control via SMBus
- Power Management Control
- Programmable PLL Bandwidth
- PLL or Fanout operation
- 3.3V Operation
- Industrial Temperature Option - PI6C20800BI
- Packaging (Pb-Free & Green):
 - 48-Pin TSSOP (A)

Description

PI6C20800B is a PCIe 3.0 compliant, high-speed, low-noise differential clock buffer designed to be a companion to PCI Express 3.0 clock generator for Intel server chipsets. The device distributes the differential SRC clock from PCIe clock generator to eight differential pairs of clock outputs either with or without PLL. The input SRC clock can be divided by 2 when SRC_DIV# is LOW. The clock outputs are controlled by input selection of SRC_STOP#, PWRDWN# and SMBus, SCLK and SDA. When input of either SRC_STOP# or PWRDWN# is LOW, the output clocks are Tristated. When PWRDWN# is LOW, the SDA and SCLK inputs must be Tristated.

Block Diagram

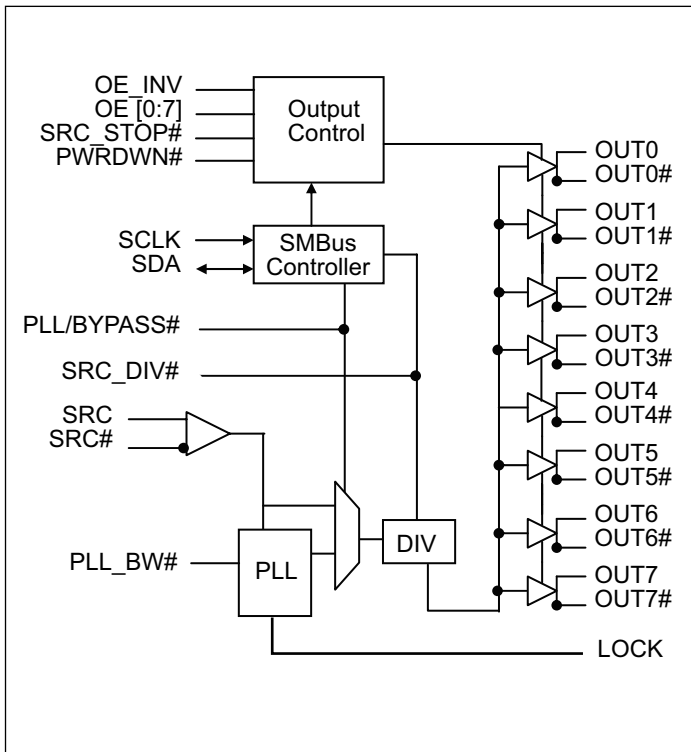

Pin Configuration (48-Pin TSSOP)

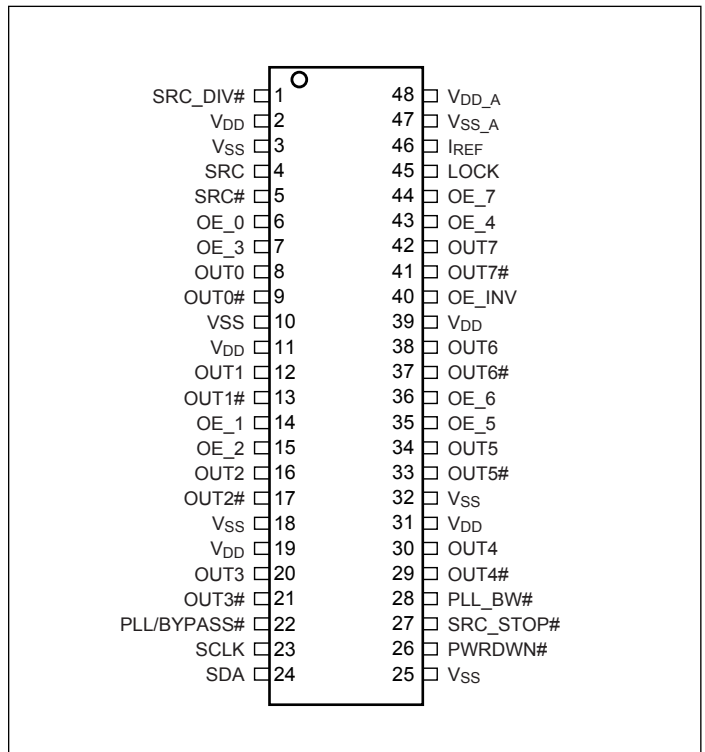

Pinout Table

Pin Name	Type	Pin #	Descriptions
SRC_DIV#	Input	1	3.3V LVTTL input for selecting input frequency divide by 2, active LOW.
SRC & SRC#	Input	4, 5	0.7V Differential SRC input from PI6C410 clock synthesizer
OE [0:7]	Input	6, 7, 14, 15, 35, 36, 43, 44	3.3V LVTTL input for enabling outputs, active HIGH.
OE_INV	Input	40	3.3V LVTTL input for inverting the OE, SRC_STOP# and PWRDWN# pins. When 0 = same stage When 1 = OE[0:7], SRC_STOP#, PWRDWN# inverted.
OUT[0:7] & OUT[0:7]#	Output	8, 9, 12, 13, 16 17, 20, 21, 29, 30, 33, 34, 37, 38, 41, 42	0.7V Differential outputs
PLL/BYPASS#	Input	22	3.3V LVTTL input for selecting fan-out of PLL operation.
SCLK	Input	23	SMBus compatible SCLOCK input
SDA	I/O	24	SMBus compatible SDATA
I _{REF}	Input	46	External resistor connection to set the differential output current
SRC_STOP#	Input	27	3.3V LVTTL input for SRC stop, active LOW
PLL_BW#	Input	28	3.3V LVTTL input for selecting the PLL bandwidth
PWRDWN#	Input	26	3.3V LVTTL input for Power Down operation, active LOW
LOCK	Output	45	3.3V LVTTL output, transition high when PLL lock is achieved (Latched output)
V _{DD}	Power	2, 11, 19, 31, 39	3.3V Power Supply for Outputs
V _{SS}	Ground	3, 10, 18, 25, 32	Ground for Outputs
V _{SS_A}	Ground	47	Ground for PLL
V _{DD_A}	Power	48	3.3V Power Supply for PLL

Serial Data Interface (SMBus)

PI6C20800B is a slave only SMBus device that supports indexed block read and indexed block write protocol using a single 7-bit address and read/write bit as shown below.

Address assignment

A6	A5	A4	A3	A2	A1	A0	R/W
1	1	0	1	1	1	0	0/1

Data Write Protocol(1)

1 bit	7 bits	1	1	8 bits	1	8 bits	1	8 bits	1	8 bits	1	1 bit
Start bit	Slave Addr	W	Ack	Register offset	Ack	Byte Count = N	Ack	Data Byte Offset	Ack	Data Byte N - 1	Ack	Stop bit

Note:

1. Register offset for indicating the starting register for indexed block write and indexed block read. Byte Count in write mode cannot be 0.

Data Read Protocol(2)

1 bit	7 bits	1	1	8 bits	1	1	7 bits	1	1	8 bits	1	8 bits	1	8 bits	1	1 bit
Start bit	Slave Addr	W	Ack	Register offset	Ack	Repeat Start	Slave Addr	R	Ack	Byte Count = N	Ack	Data Byte Offset	Ack	Data Byte N - 1	Not Ack	Stop bit

Note:

1. Register offset for indicating the starting register for indexed block write and indexed block read.

Data Byte 0: Control Register

Bit	Descriptions	Type	Power Up Condition	Output(s) Affected	Pin
0	SRC_DIV# 0 = Divide by 2 1 = Normal	RW	1 = x1	OUT[0:7], OUT[0:7]#	NA
1	PLL/BYPASS# 0 = Fanout 1 = PLL	RW	1 = PLL	OUT[0:7], OUT[0:7]#	NA
2	PLL Bandwidth 0 = HIGH Bandwidth, 1 = LOW Bandwidth	RW	1 = Low	OUT[0:7], OUT[0:7]#	NA
3	RESERVED				
4	RESERVED				
5	RESERVED				
6	SRC_STOP# 0 = Driven when stopped 1 = Tristate	RW	0 = Driven when stopped	OUT[0:7], OUT[0:7]#	
7	PWRDWN# 0 = Driven when stopped 1 = Tristate	RW	0 = Driven when stopped	OUT[0:7], OUT[0:7]#	NA

Data Byte 1: Control Register

Bit	Descriptions	Type	Power Up Condition	Output(s) Affected	Pin
0	OUTPUTS enable 1 = Enabled 0 = Disabled	RW	1 = Enabled	OUT0, OUT0#	NA
1		RW	1 = Enabled	OUT1, OUT1#	NA
2		RW	1 = Enabled	OUT2, OUT2#	NA
3		RW	1 = Enabled	OUT3, OUT3#	NA
4		RW	1 = Enabled	OUT4, OUT4#	NA
5		RW	1 = Enabled	OUT5, OUT5#	NA
6		RW	1 = Enabled	OUT6, OUT6#	NA
7		RW	1 = Enabled	OUT7, OUT7#	NA

Data Byte 2: Control Register

Bit	Descriptions	Type	Power Up Condition	Output(s) Affected	Pin
0	Allow control of OUTPUTS with assertion of SRC_STOP# 0 = Free running 1 = Stopped with SRC_Stop#	RW	0 = Free running	OUT0, OUT0#	NA
1		RW	0 = Free running	OUT1, OUT1#	NA
2		RW	0 = Free running	OUT2, OUT2#	NA
3		RW	0 = Free running	OUT3, OUT3#	NA
4		RW	0 = Free running	OUT4, OUT4#	NA
5		RW	0 = Free running	OUT5, OUT5#	NA
6		RW	0 = Free running	OUT6, OUT6#	NA
7		RW	0 = Free running	OUT7, OUT7#	NA

Data Byte 3: Control Register

Bit	Descriptions	Type	Power Up Condition	Output(s) Affected	Pin
0	RESERVED	RW			
1		RW			
2		RW			
3		RW			
4		RW			
5		RW			
6		RW			
7		RW			

Data Byte 4: Pericom ID Register

Bit	Descriptions	Type	Power Up Condition	Output(s) Affected	Pin
0	Pericom ID	R	0	NA	NA
1		R	0	NA	NA
2		R	0	NA	NA
3		R	0	NA	NA
4		R	0	NA	NA
5		R	1	NA	NA
6		R	0	NA	NA
7		R	0	NA	NA

Functionality

PWRDWN#	OUT	OUT#	SRC_Stop#	OUT	OUT#
1	Normal	Normal	1	Normal	Normal
0	$I_{REF} \times 2$ or Float	LOW	0	$I_{REF} \times 6$ or Float	LOW

Power Down (PWRDWN# assertion)

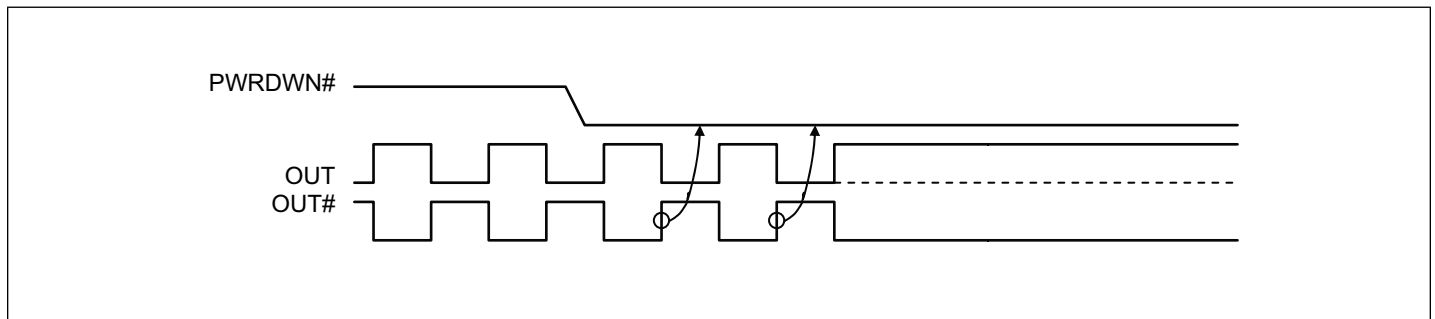

Power Down (PWRDWN# De-assertion)

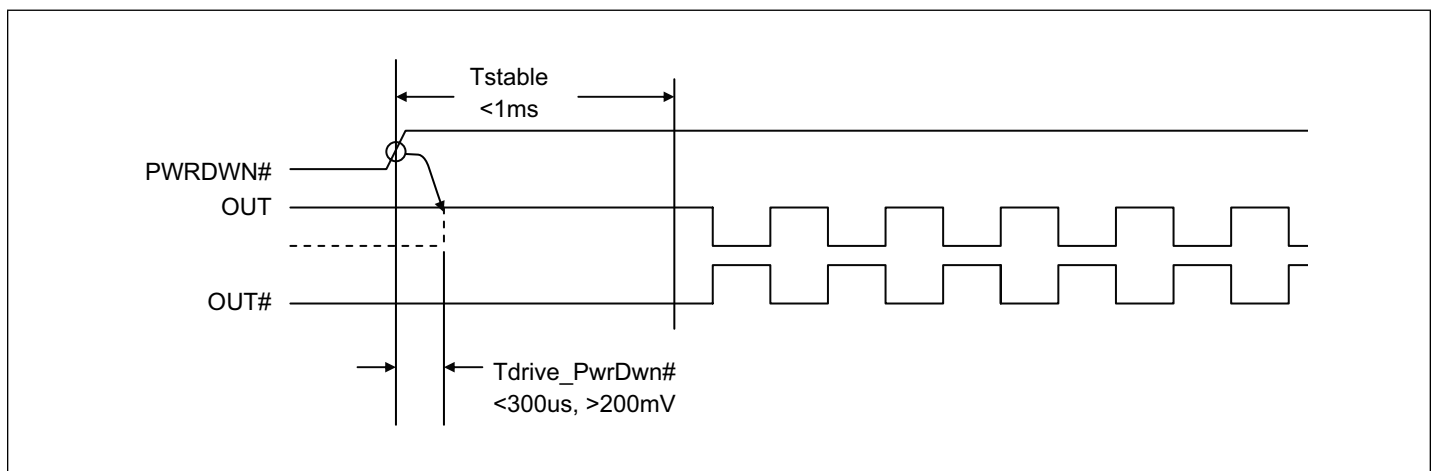

Current-mode output buffer characteristics of OUT[0:7], OUT[0:7]#

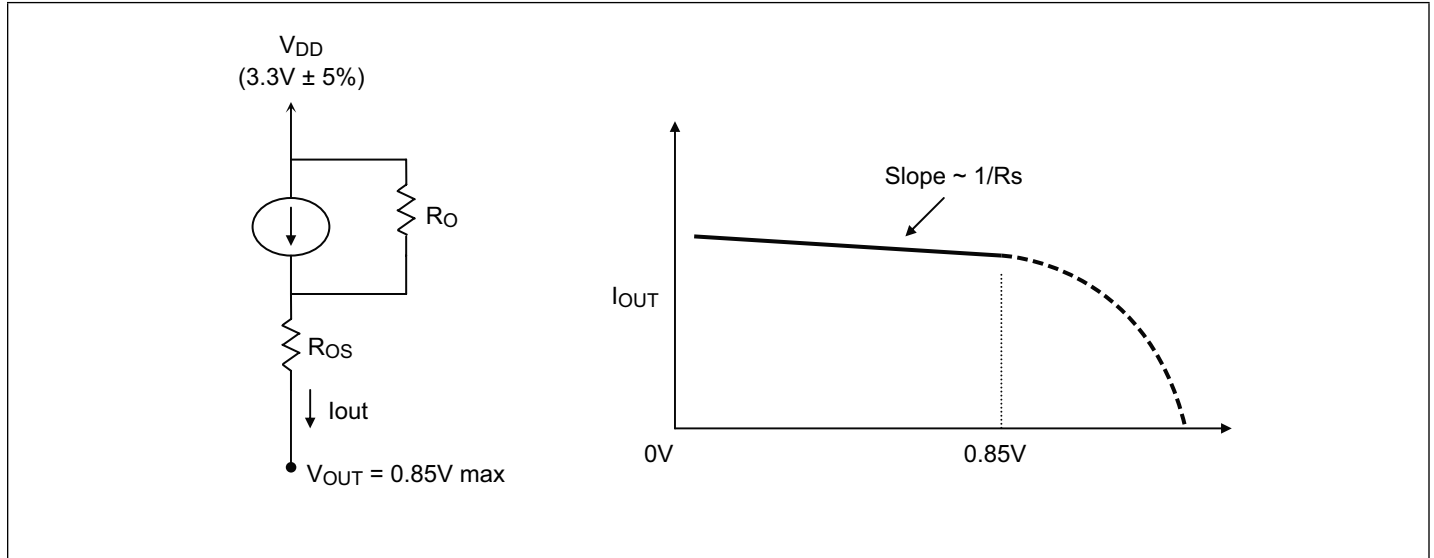

Differential Clock Buffer Characteristics

Symbol	Minimum	Maximum
R_O	3000Ω	N/A
R_{OS}	unspecified	unspecified
V_{OUT}	N/A	850mV

Current Accuracy

Symbol	Conditions	Configuration	Load	Min.	Max.
I_{OUT}	$V_{DD} = 3.30 \pm 5\%$	$R_{REF} = 475\Omega \text{ 1\%}$ $I_{REF} = 2.32\text{mA}$	Nominal test load for given configuration	-12% $I_{NOMINAL}$	+12% $I_{NOMINAL}$

Note:

- $I_{NOMINAL}$ refers to the expected current based on the configuration of the device.

Differential Clock Output Current

Board Target Trace/Term Z	Reference R, $I_{ref} = V_{DD}/(3xRr)$	Output Current	$V_{OH} @ Z$
100Ω (100Ω differential \approx 15% coupling ratio)	$R_{REF} = 475\Omega \text{ 1\%}$, $I_{REF} = 2.32\text{mA}$	$I_{OH} = 6 \times I_{REF}$	0.7V @ 50

Absolute Maximum Ratings⁽¹⁾ (Over operating free-air temperature range)

Symbol	Parameters	Min.	Max.	Units
V _{DD_A}	3.3V Core Supply Voltage	-0.5	4.6	V
V _{DD}	3.3V I/O Supply Voltage	-0.5	4.6	
V _{IH}	Input HIGH Voltage		4.6	
V _{IL}	Input LOW Voltage	-0.5		
T _s	Storage Temperature	-65	150	°C
V _{ESD}	ESD Protection	2000		V

Note:

1. Stress beyond those listed under “Absolute Maximum Ratings” may cause permanent damage to the device.

DC Electrical Characteristics (V_{DD} = 3.3±5%, V_{DD_A} = 3.3±5%)

Symbol	Parameters	Condition	Min.	Max.	Units
V _{DD_A}	3.3V Core Supply Voltage		3.135	3.465	V
V _{DD}	3.3V I/O Supply Voltage		3.135	3.465	
V _{IH}	3.3V Input HIGH Voltage		2.0	V _{DD} + 0.3	
V _{IL}	3.3V Input LOW Voltage		V _{SS} - 0.3	0.8	
I _{IK}	Input Leakage Current	0 < V _{IN} < V _{DD}	-5	+5	µA
V _{OH}	3.3V Output HIGH Voltage	I _{OH} = -1mA	2.4		V
V _{OL}	3.3V Output LOW Voltage	I _{OL} = 1mA		0.4	
I _{OH}	Output HIGH Current	I _{OH} = 6 x I _{REF} I _{REF} = 2.32mA	12.2	15.6	mA
C _{IN}	Logic Input Pin Capacitance		1.5	5	
C _{OUT}	Output Pin Capacitance			6	pF
L _{PIN}	Pin Inductance			7	nH
I _{DD}	Power Supply Current	V _{DD} = 3.465V, F _{CPU} = 100MHz		250	mA
I _{SS}	Power Down Current	Driven outputs		80	
I _{SS}	Power Down Current	Tristate outputs		12	
T _A	Ambient Temperature	Commercial (PI6C20800B)	0	70	°C
		Industrial (PI6C20800BI)	-40	85	

AC Switching Characteristics^(1,2,3) ($V_{DD} = 3.3 \pm 5\%$, $V_{DD,A} = 3.3 \pm 5\%$)

Symbol	Parameters		Min	Typ.	Max.	Units	Notes	
F_{in}	SRC/SRC# Input Frequency PLL Mode		95		105	MHz	6	
	SRC/SRC# Input Frequency Bypass Mode		95		400	MHz	6	
T_{rise} / T_{fall}	Rise and Fall Time (measured between 0.175V to 0.525V)		175		700	ps	2	
$\Delta T_{rise} / \Delta T_{fall}$	Rise and Fall Time Variation				125		2	
T_{pd}	Input to Output Propagation Delay	PLL Mode	PI6C20800B	-250		250	ps	
			PI6C20800BI	-450		450		
		Bypass Mode	PI6C20800B	-7.5		7.5	ns	
			PI6C20800BI	-8		8		
T_{skew}	Output-to-Output Skew (PI6C20800B)				50	ps	3	
	Output-to-Output Skew (PI6C20800BI)				65		3	
V_{HIGH}	Voltage HIGH (Measured at 100MHz @ 3.3V)		600		900	mV	2	
V_{OVS}	Max. Voltage				1150			
V_{UDS}	Min. Voltage		-300					
V_{LOW}	Voltage LOW		-150		+150		2	
V_{cross}	Absolute crossing poing voltages		250		550		2	
ΔV_{cross}	Total Variation of V_{cross} over all edges				140		2	
T_{DC}	Duty Cycle (Measured at 100 MHz)		45		55	%	3	
$T_{jyc-cyc}$	Jitter, Cycle-to-cycle (PLL Mode, Measurement for differential waveform)				60	ps	4	
	Jitter, Cycle-to-cycle (BYPASS mode as additive jitter)							
J_{add}	Additive RMS phase jitter for PCIe 2.0		<0		1	ps	5	
J_{add}	RMS phase jitter for PCIe 3.0	PLL L-BW @ 2M & 5M 1 st H3		1.115	3	ps		
		PLL L-BW @ 2M & 4M 1 st H3		1.211	3			
		PLL L-BW @ 2M & 5M 1 st H3		1.116	3			
		PLL L-BW @ 2M & 4M 1 st H3		1.425	3			
		PLL H-BW @ 2M & 5M 1 st H3		0.646	1			
		PLL H-BW @ 2M & 4M 1 st H3		0.644	1			
		PLL H-BW @ 2M & 5M 1 st H3		0.646	1			
		PLL H-BW @ 2M & 4M 1 st H3		0.579	1			

Notes:

1. Test configuration is $R_s = 33.2\Omega$, $R_p = 49.9\Omega$, and 2pF.
2. Measurement taken from Single Ended waveform.
3. Measurement taken from Differential waveform.
4. Measured using M1 timing analyzer from Amherst.
5. Additive jitter is calculated from input and output RMS phase jitter by using PCIe 2.0 filter. ($J_{add} = \sqrt{(\text{output jitter})^2 - (\text{input jitter})^2}$)
6. -0.5% downnsread input

Configuration Test Load Board Termination

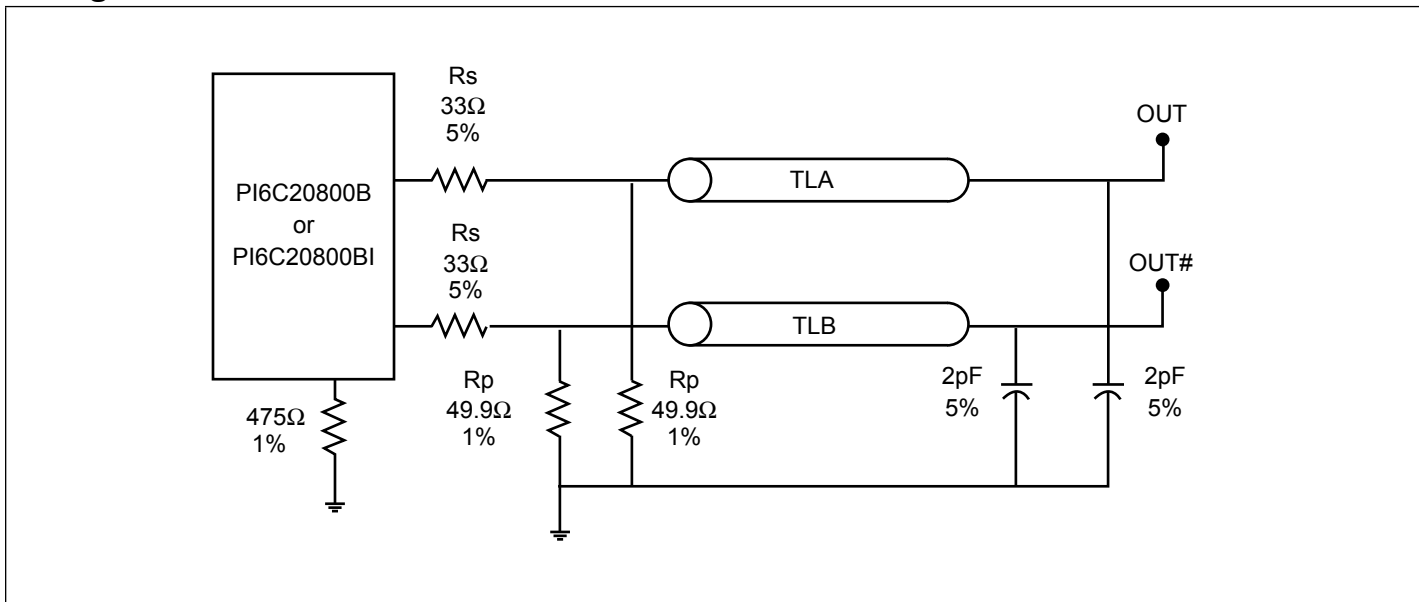

Packaging Mechanical: 48-Pin TSSOP (A)

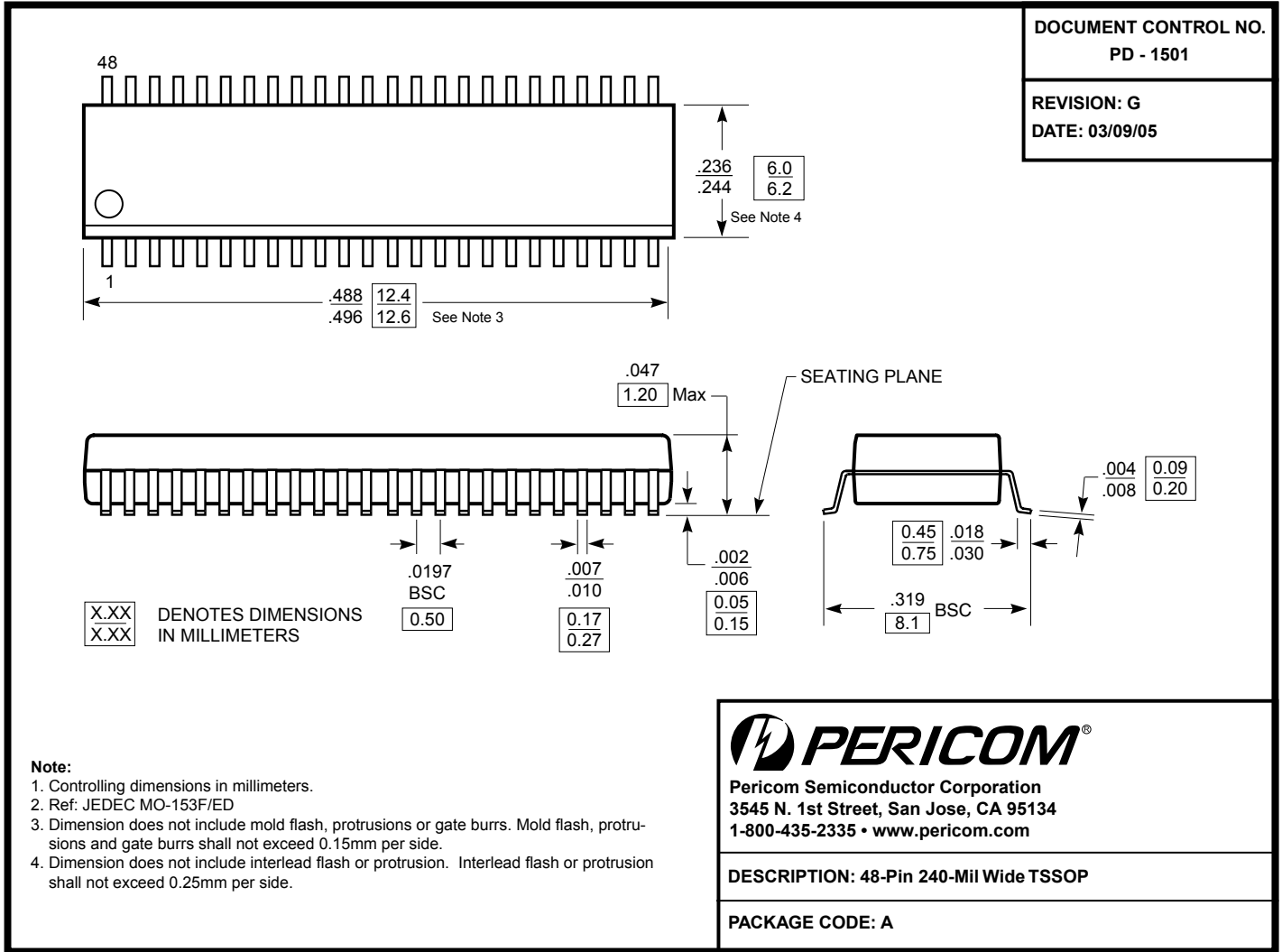

Ordering Information^(1,2)

Ordering Code	Package Code	Package Description
PI6C20800BAE	AE	48-pin, 240-mil wide, TSSOP, Pb-Free and Green
PI6C20800BIAE	AE	48-pin, 240-mil wide, TSSOP, Pb-Free and Green (Industrial)

Notes:

1. Thermal characteristics can be found on the company web site at www.pericom.com/packaging/
2. E = Pb-free and Green
3. Adding an X suffix = Tape/Reel