

CQ223-2M  
CQ223-2N

SURFACE MOUNT  
2 AMP SILICON TRIAC  
600 THRU 800 VOLTS



SOT-223 CASE



[www.centrasemi.com](http://www.centrasemi.com)

**DESCRIPTION:**

The CENTRAL SEMICONDUCTOR CQ223-2M series type is an Epoxy Molded Silicon Triac designed for full wave AC control applications featuring gate triggering in all four (4) quadrants.

**MARKING: FULL PART NUMBER**

MAXIMUM RATINGS: ( $T_C=25^\circ\text{C}$ unless otherwise noted)	SYMBOL	CQ223-2M	CQ223-2N	UNITS
Peak Repetitive Off-State Voltage	$V_{\text{DRM}}$	600	800	V
RMS On-State Current ( $T_C=80^\circ\text{C}$ )	$I_{\text{T(RMS)}}$		2.0	A
Peak One Cycle Surge, $t=10\text{ms}$	$I_{\text{TSM}}$		10	A
$I^2t$ Value for Fusing, $t=10\text{ms}$	$I^2t$		0.5	$\text{A}^2\text{s}$
Peak Gate Power, $t_p=10\mu\text{s}$	$P_{\text{GM}}$		3.0	W
Average Gate Power Dissipation	$P_{\text{G(AV)}}$		0.2	W
Peak Gate Current, $t_p=10\mu\text{s}$	$I_{\text{GM}}$		1.2	A
Operating Junction Temperature	$T_{\text{J}}$	-40 to +125		$^\circ\text{C}$
Storage Temperature	$T_{\text{stg}}$	-40 to +150		$^\circ\text{C}$
Thermal Resistance	$\Theta_{\text{JA}}$		62.5	$^\circ\text{C/W}$

**ELECTRICAL CHARACTERISTICS: ( $T_C=25^\circ\text{C}$  unless otherwise noted)**

SYMBOL	TEST CONDITIONS	MIN	TYP	MAX	UNITS
$I_{\text{DRM}}$	Rated $V_{\text{DRM}}$ , $R_{\text{GK}}=1\text{K}\Omega$			5.0	$\mu\text{A}$
$I_{\text{DRM}}$	Rated $V_{\text{DRM}}$ , $R_{\text{GK}}=1\text{K}\Omega$ , $T_C=125^\circ\text{C}$			200	$\mu\text{A}$
$I_{\text{GT}}$	$V_{\text{D}}=12\text{V}$ , QUAD I, II, III		1.35	5.00	mA
$I_{\text{GT}}$	$V_{\text{D}}=12\text{V}$ , QUAD IV		3.75	8.00	mA
$I_{\text{H}}$	$R_{\text{GK}}=1\text{K}\Omega$		1.2	5.0	mA
$V_{\text{GT}}$	$V_{\text{D}}=12\text{V}$ , QUAD I, II, III, IV		1.1	1.8	V
$V_{\text{TM}}$	$I_{\text{TM}}=2.0\text{A}$ , $t_p=380\mu\text{s}$		1.50	1.75	V
$V_{\text{TM}}$	$I_{\text{TM}}=3.0\text{A}$ , $t_p=380\mu\text{s}$		1.7	2.0	V
dv/dt	$V_{\text{D}}=2/3 V_{\text{DRM}}$ , $T_C=125^\circ\text{C}$	2.5			$\text{V}/\mu\text{s}$

R1 (24-June 2010)

CQ223-2M  
CQ223-2N



**SURFACE MOUNT  
2 AMP SILICON TRIAC  
600 THRU 800 VOLTS**

**SOT-223 CASE - MECHANICAL OUTLINE**

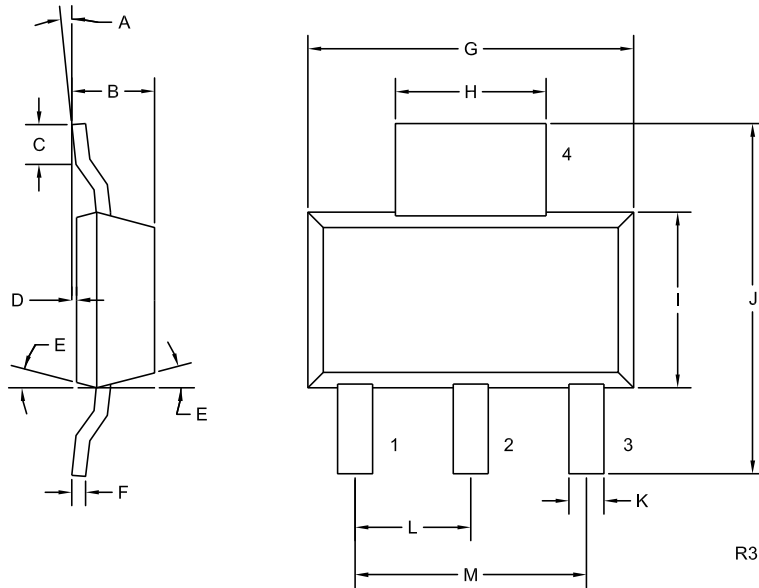

**LEAD CODE:**

- 1) MT1
- 2) MT2
- 3) Gate
- 4) MT2

**MARKING:**

**FULL PART NUMBER**

DIMENSIONS				
SYMBOL	INCHES		MILLIMETERS	
	MIN	MAX	MIN	MAX
A	0°	10°	0°	10°
B	0.059	0.071	1.50	1.80
C	0.018	--	0.45	--
D	0.000	0.004	0.00	0.10
E	15°		15°	
F	0.009	0.014	0.23	0.35
G	0.248	0.264	6.30	6.70
H	0.114	0.122	2.90	3.10
I	0.130	0.146	3.30	3.70
J	0.264	0.287	6.70	7.30
K	0.024	0.033	0.60	0.85
L	0.091		2.30	
M	0.181		4.60	

SOT-223 (REV: R3)

R1 (24-June 2010)